

2001 BUELL P3

SERVICE MANUAL

Part Number 99491-01Y

Section 1: Maintenance

Section 2: Chassis

Section 3: Engine

Section 4: Fuel System

Section 5: Starter

Section 6: Drive/Transmission

Section 7: Electrical

Appendix

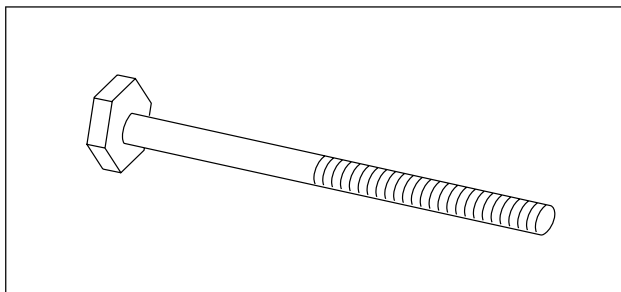

Part No. B-35316-5 12 Inch Bolt.
Used with Part No. HD-39302.

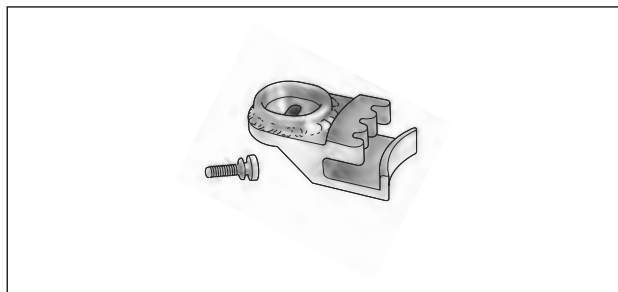

Part No. B-43982 Sprocket Locking Tool

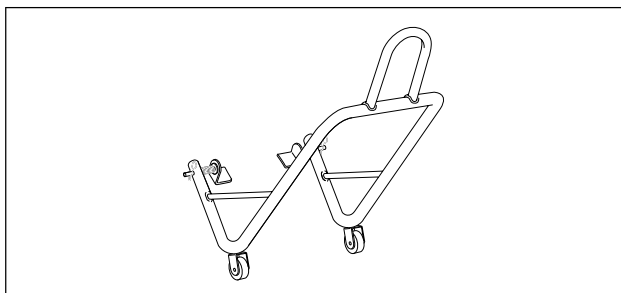

**Part No. B-41174 Rear Wheel Support Stand and
Part No. B-41174-2 Replacement Pad.**

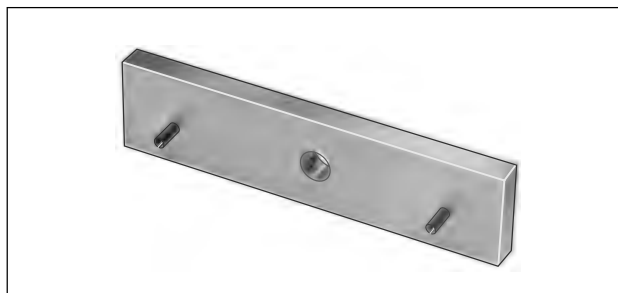

Part No. B-43983 Main Drive Gear Cross Plate.
Used with Part No. HD-35316A.

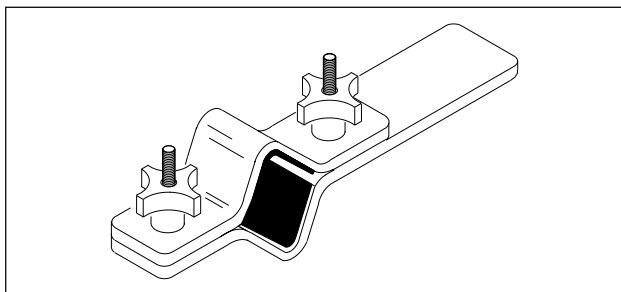

Part No. B-41177 Front Fork Holding Tool

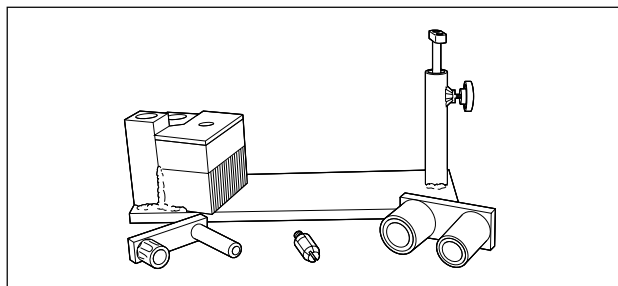

Part No. B-43985 Transmission Remover/Installer

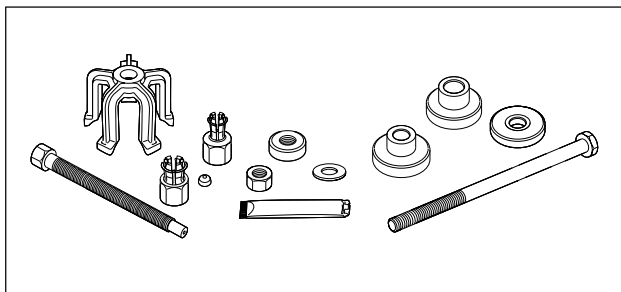

Part No. B-43933 Wheel Bearing Remover/Installer.
Use with Part No. HD-44060.

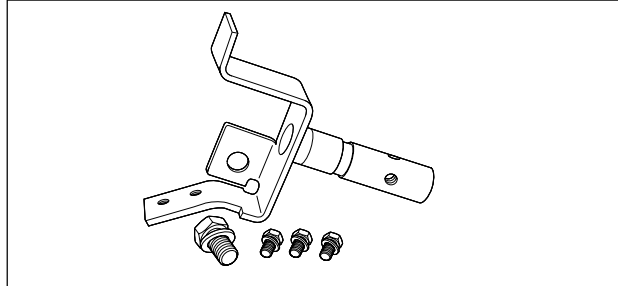

Part No. B-43987 Engine Cradle
Used with HD-42310

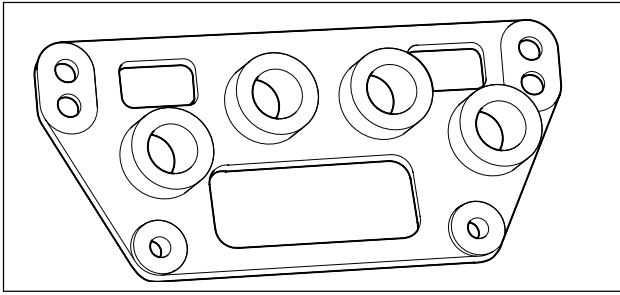

Part No. B-43988 Camshaft Bushing Reamer Fixture.
Use with Part No. HD-38871-2.

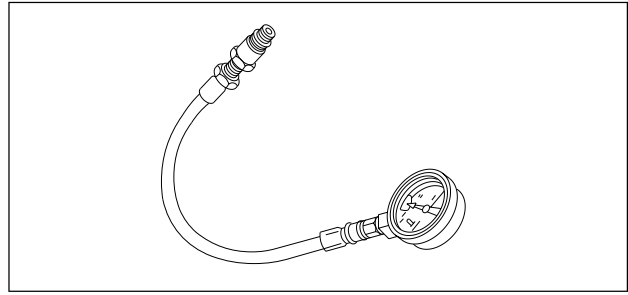

Part No. HD-33223-1 Cylinder Compression Gauge

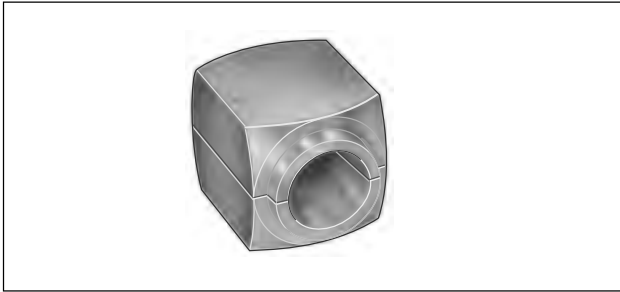

Part No. B-43991 Fork Seal/Bushing Driver

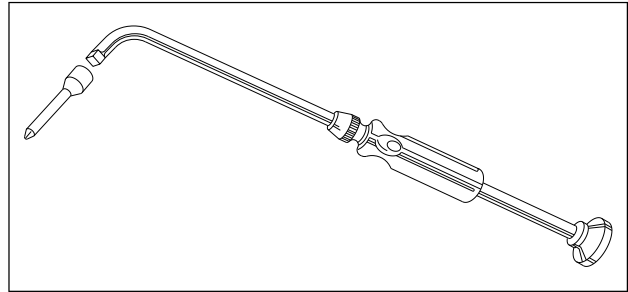

Part No. HD-33413-A Carburetor Idle Adjustment Tool

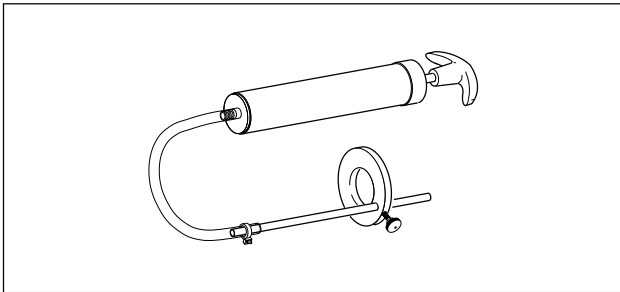

Part No. B-59000A Pro Level Oil Gauge

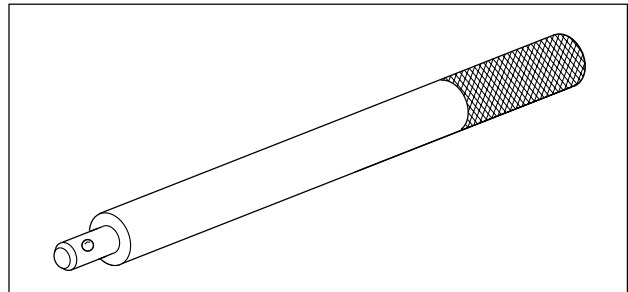

Part No. HD-33416 Universal Driver Handle

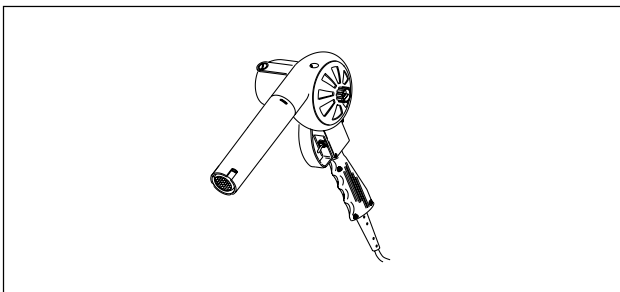

Part No. HD-25070 Robinair Heat Gun

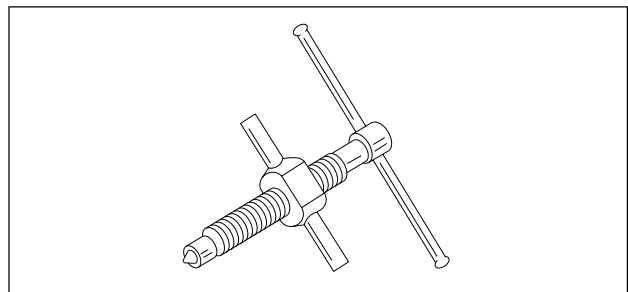

Part No. HD-33418 Universal Puller Forcing Screw

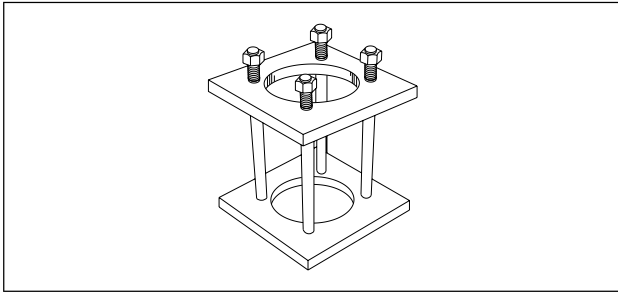

Part No. HD-33446A Cylinder Torque Plates and Torque Plate Bolts Part No. HD-33446-86.

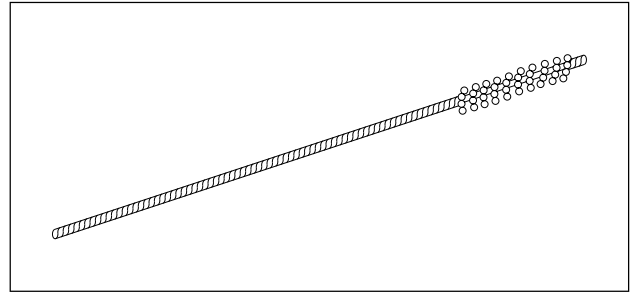

Part No. HD-34723 Valve Guide Hone (8 mm)

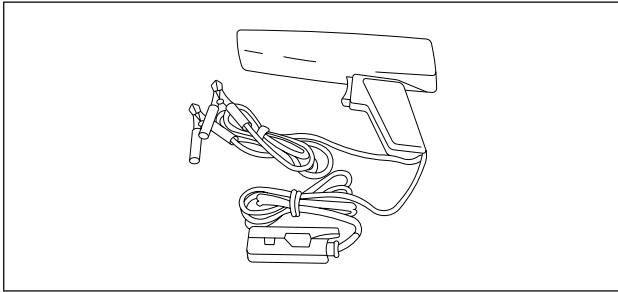

Part No. HD-33813 Inductive Timing Light

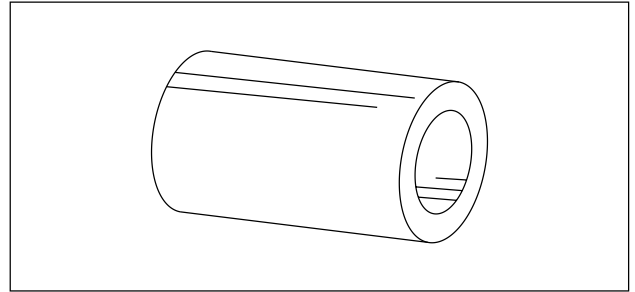

Part No. HD-34731 Shoulderless Valve Guide Installation Tool

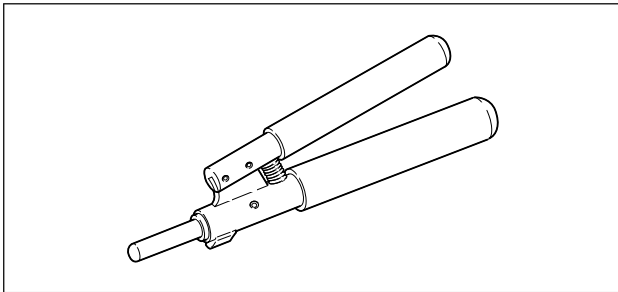

Part No. HD-34623B Piston Pin Retaining Ring Installer/Remover

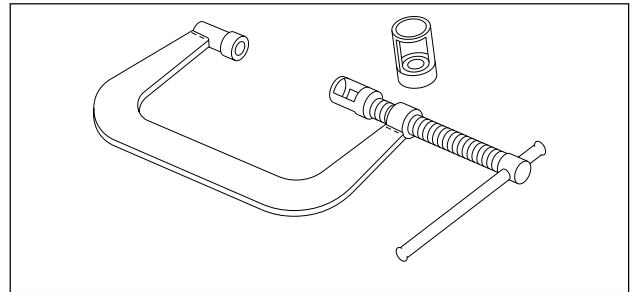

Part No. HD-34736B Valve Spring Compressor

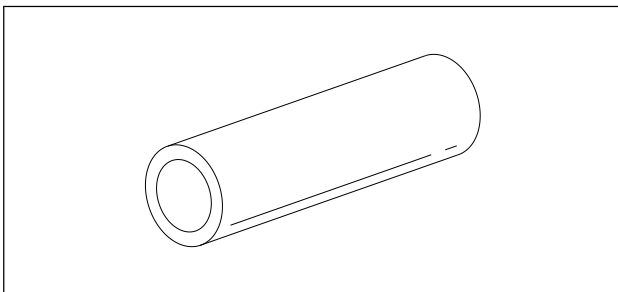

Part No. HD-34643A Shoulderless Valve Guide Seal Installer

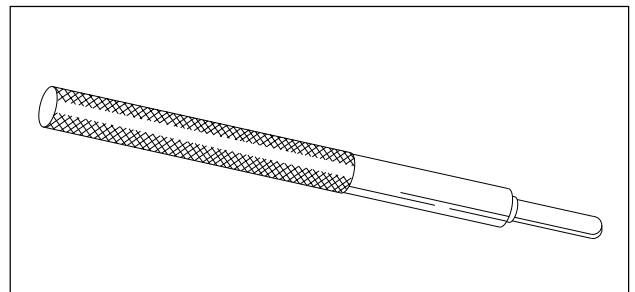

Part No. HD-34740 Driver Handle and Remover. Use with Part No. HD-34643A and art No. HD-34731.

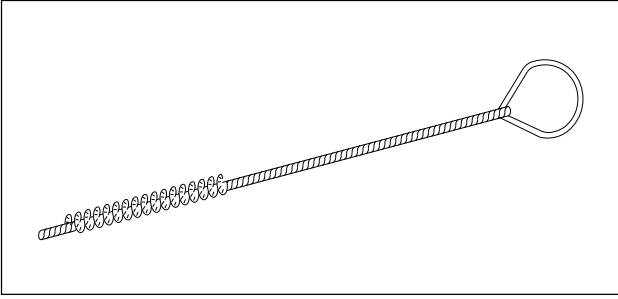

Part No. HD-34751 Nylon Valve Guide Brush

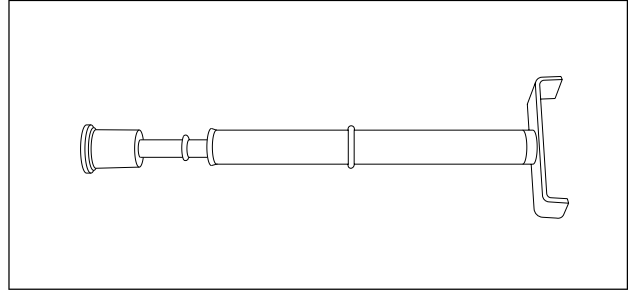

Part No. HD-35381 Belt Tension Gauge

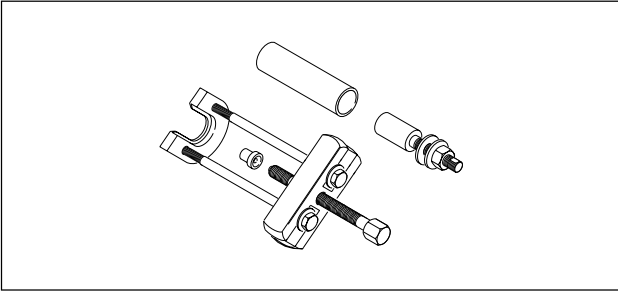

Part No. HD-34902-B Primary Bearing Race Remover/Installer

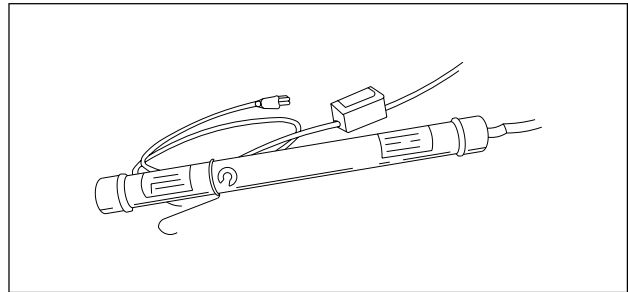

Part No. HD-35457 Black Light Leak Detector

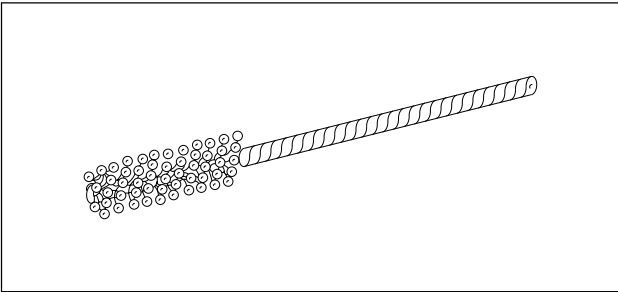

Part No. HD-35102 Wrist Pin Bushing Hone (20 mm)

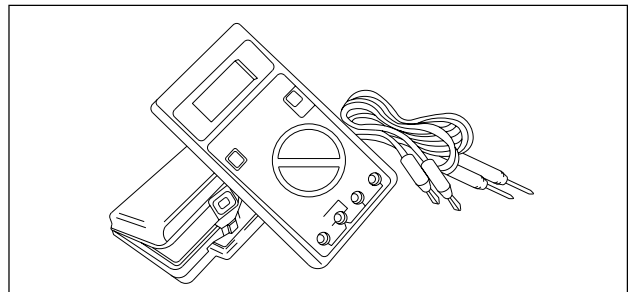

Part No. HD-35500A Digital Multi-Meter (FLUKE 23)

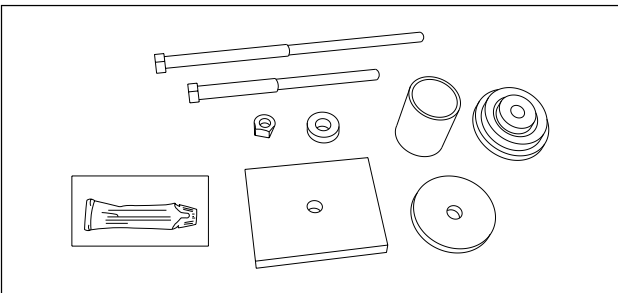

Part No. HD-35316-A Main Drive Gear Remover/Installer and Main Drive Gear Bearing Installer.

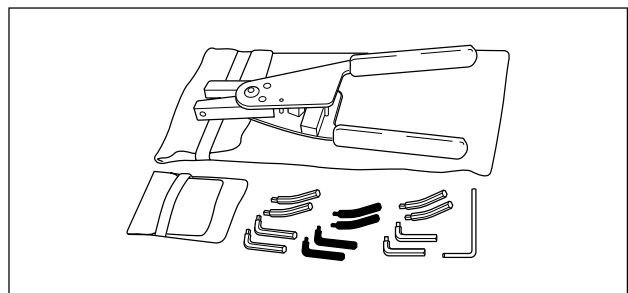

Part No. HD-35518 Internal/External Retaining Ring Pliers

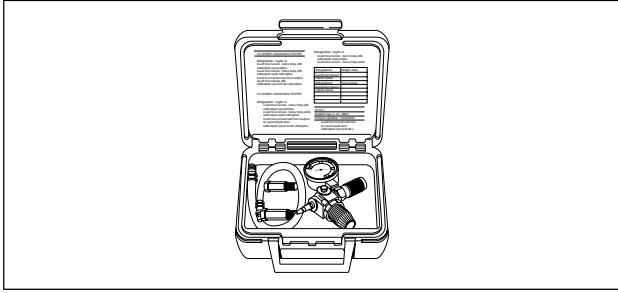

Part No. HD-35667A Cylinder Leakdown Tester

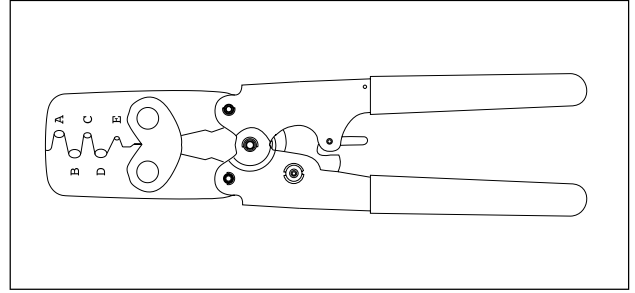

Part No. HD-38125-7 Packard Terminal Crimp Tool
(Sealed connectors)

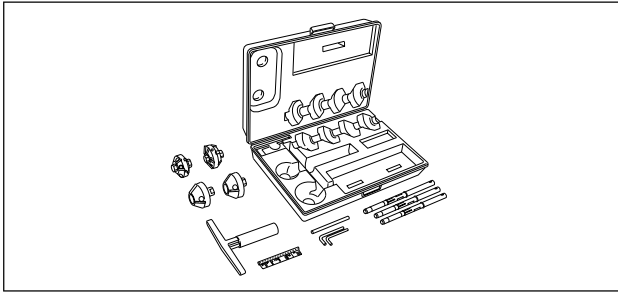

Part No. HD-35758 Neway Valve Seat Cutter Set

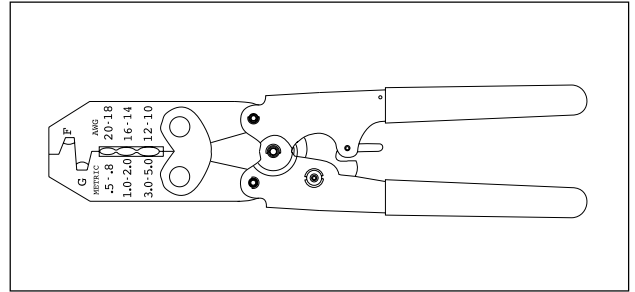

Part No. HD-38125-8 Packard Terminal Crimp Tool

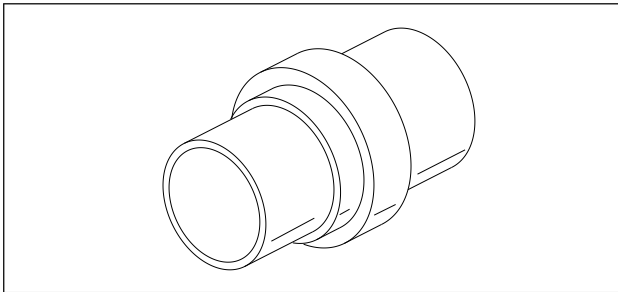

Part No. HD-37842A Inner/Outer Main Drive Gear
Needle Bearing Installer

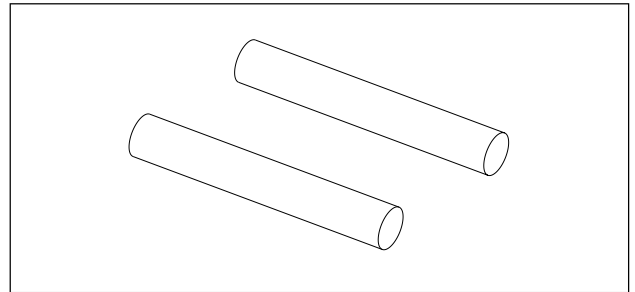

Part No. HD-38361 Cam Gear Gauge Pin Set
(0.108 in. (2.74 mm) Diameter)

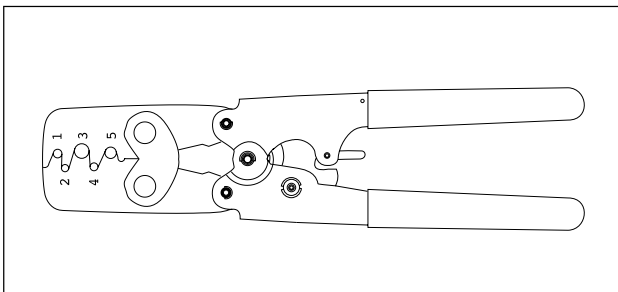

Part No. HD-38125-6 Packard Terminal Crimp Tool
(Sealed and non-sealed connectors)

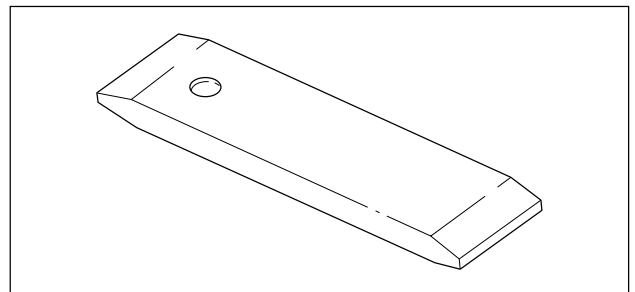

Part No. HD-38362 Sprocket Locking Link

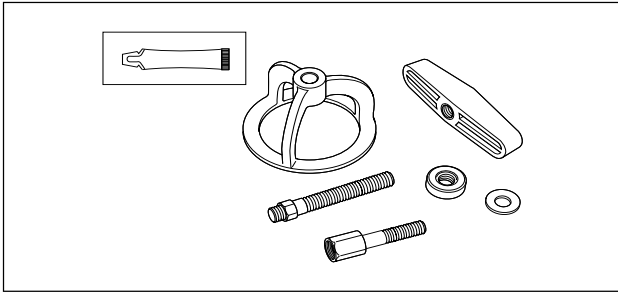

Part No. HD-38515-A Clutch Spring Compressing Tool and Part No. HD-38515-91 Forcing Screw.

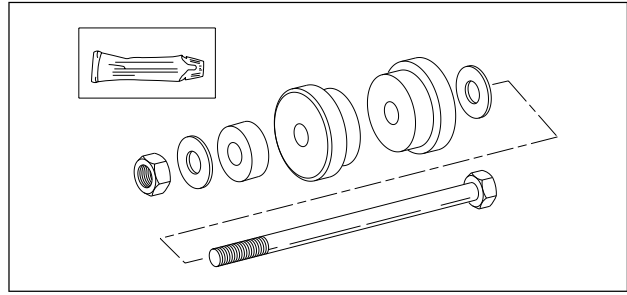

Part No. HD-39302 Steering Head Bearing Race Installer

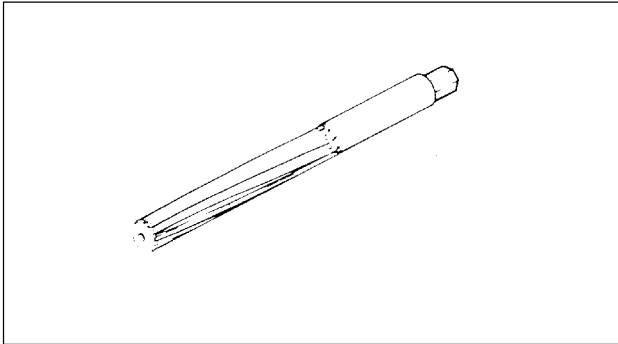

Part No. HD-38871- 2 Reamer. Use with Part No. B-43988 Camshaft Bushing Reamer Fixture

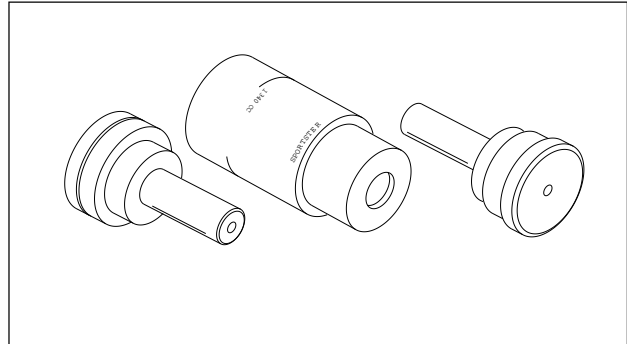

Part No. HD-39458 Sprocket Shaft Bearing Outer Race Installer

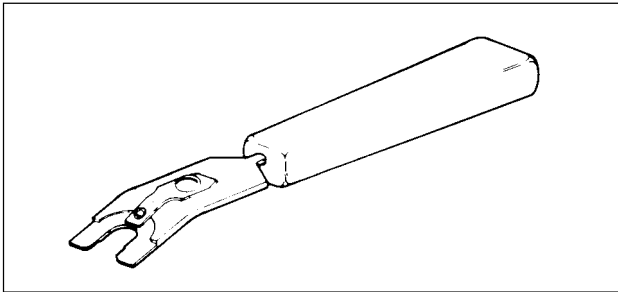

Part No. HD-39151 Shift Drum Retaining Ring Installer

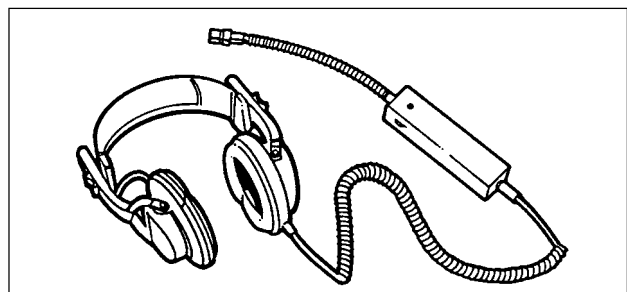

Part No. HD-39565 Engine Sound Probe

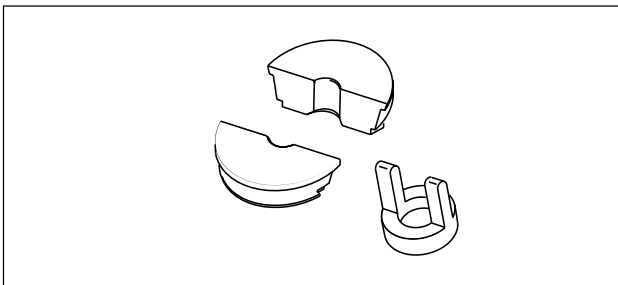

Part No. HD-39301-A Steering Head Bearing Race Remover

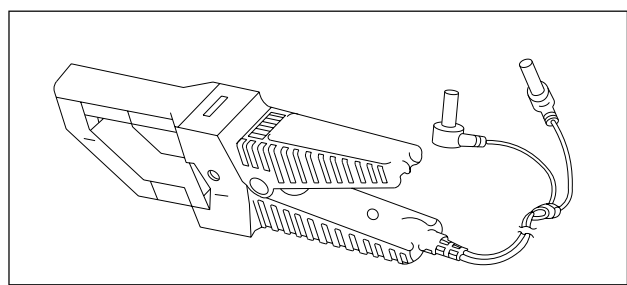

Part No. HD-39617 Inductive Amp Probe. Use with Part No. HD-35500A.

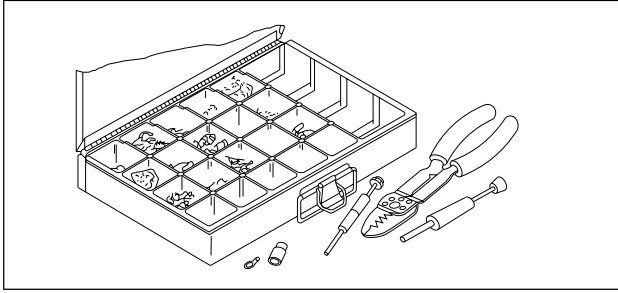

Part No. HD-39621 Electrical Terminal Repair Kit

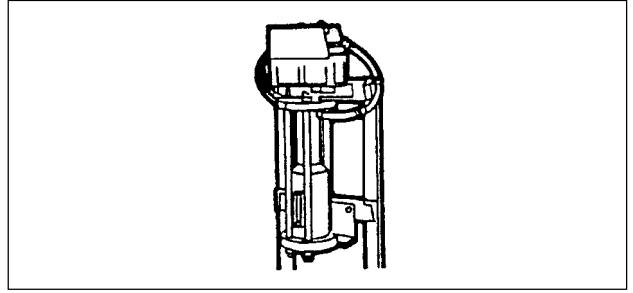

Part No. HD-39823 Oil Filter Crusher, Large

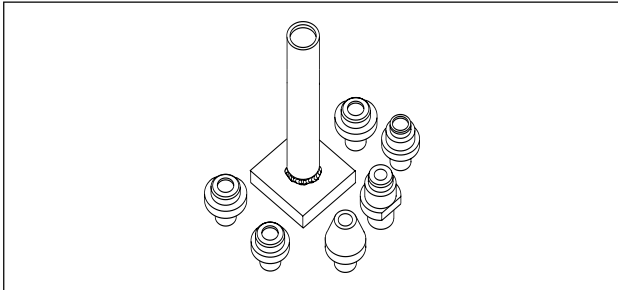

Part No. HD-39782 Cylinder Head Support

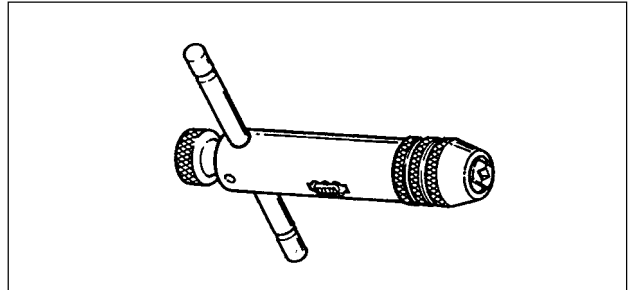

Part No. HD-39847 Universal Ratcheting Tap/
Reamer Handle

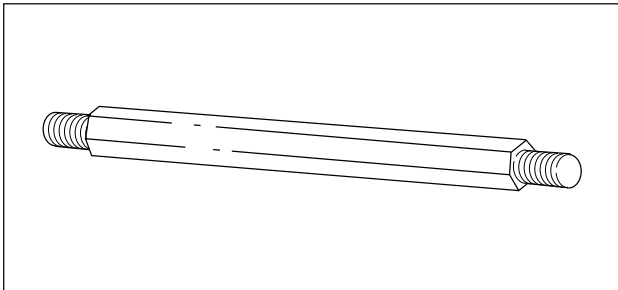

Part No. HD-39786 Cylinder Head Holding Fixture

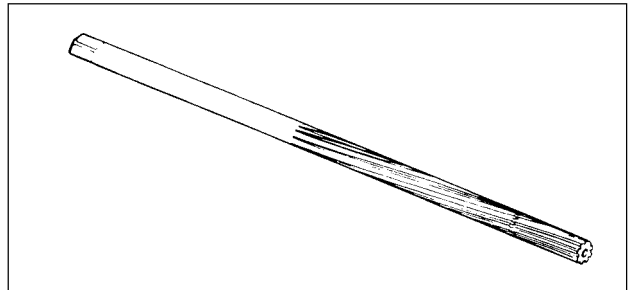

Part No. HD-39932 (Steel) or HD-39932-CAR (Carbide)
Intake and Exhaust Valve Guide Reamer.

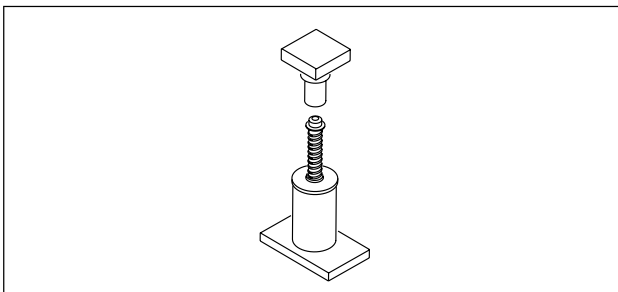

Part No. HD-39800 Oil Filter Crusher, Small

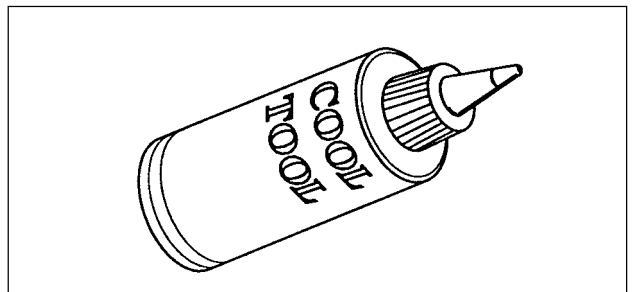

Part No. HD-39964 Reamer Lubricant (Cool Tool)

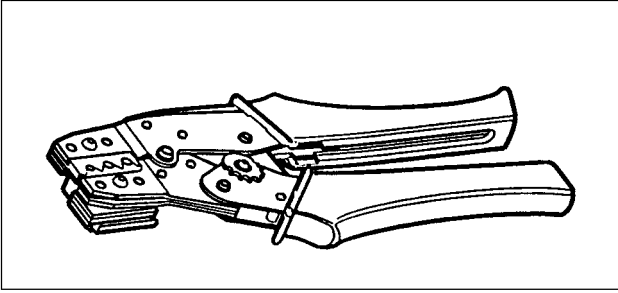

Part No. HD-39965 Deutsch Terminal Crimp Tool

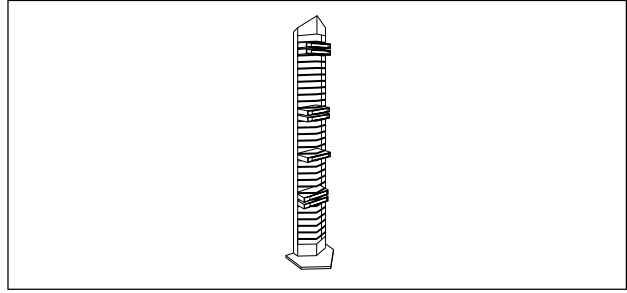

Part No. HD-41155 VHS Video Shelf

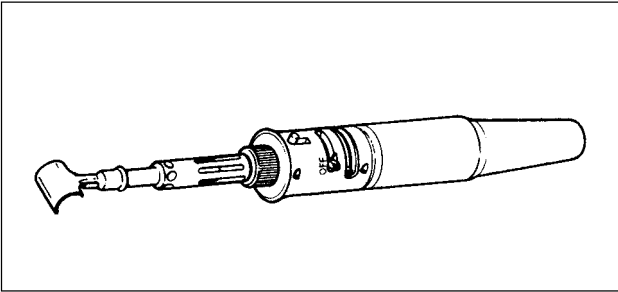

Part No. HD-39969 Ultra-Torch UT-100

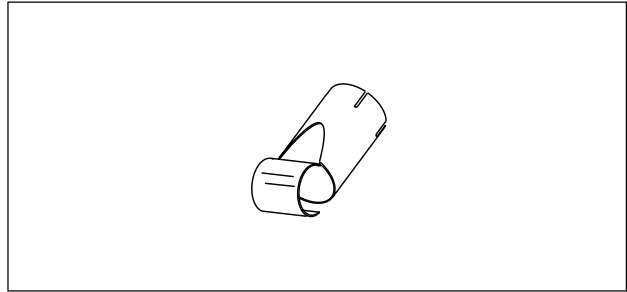

Part No. HD-41183 Heat Shield Attachment.
Use with Part No. HD-25070.

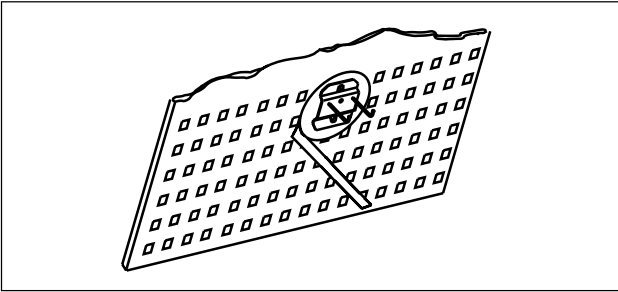

Part No. BU-44473 Tool Organizational System

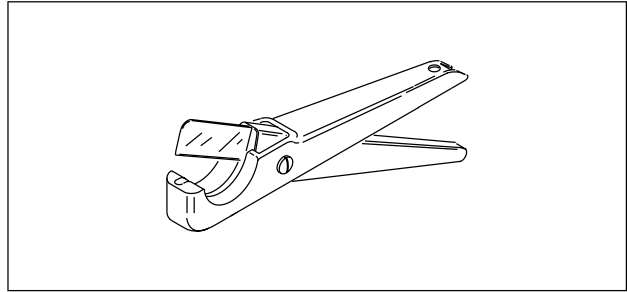

Part No. HD-41185 Hose Cutting Tool

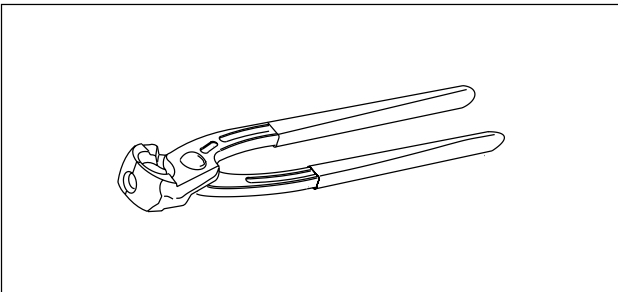

Part No. HD-41137 Hose Clamp Pliers

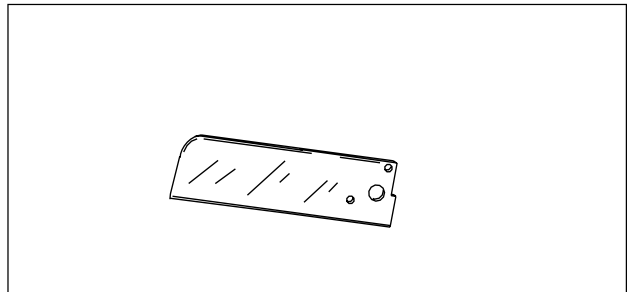

Part No. HD-41185-1 Oil Hose Cutter-Replacement Blade

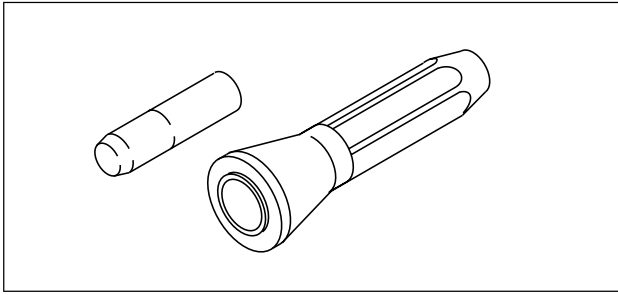

Part No. HD-41405 Main Drive Gear Seal Installer

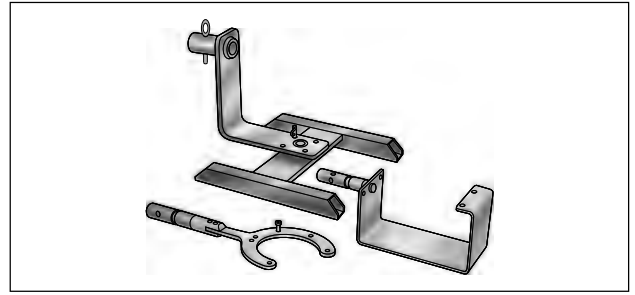

Part No. HD-42310 Engine/Transmission Stand

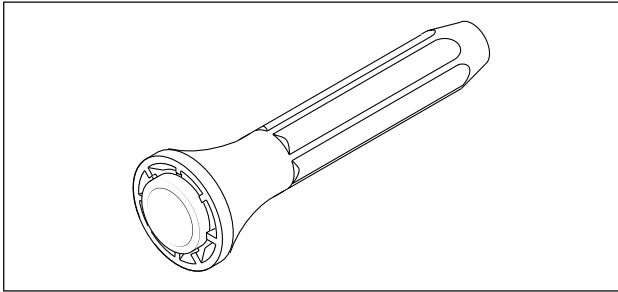

Part No. HD-41496 Main Drive Gear Seal Installer

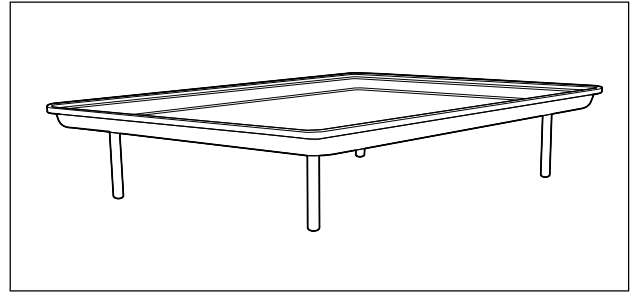

Part No. HD-42310-150 Drip Tray.
Use with Part No. HD-42310.

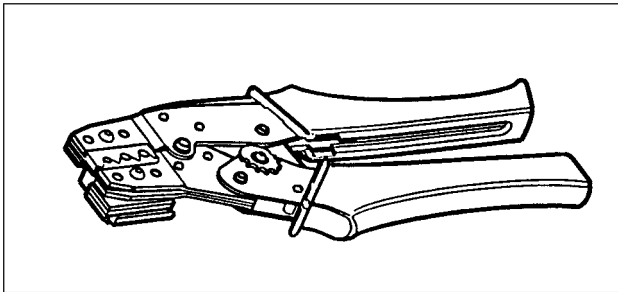

Part No. HD-41609 Amp Terminal Crimp Tool

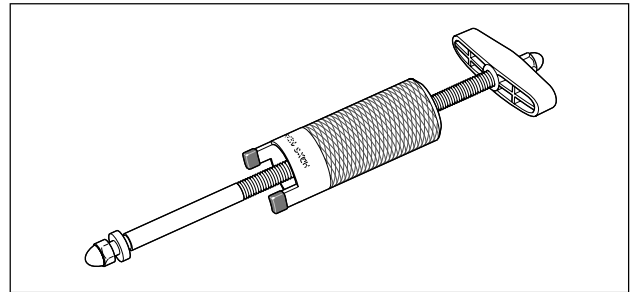

Part No. HD-42320 Piston Pin Remover/Installer

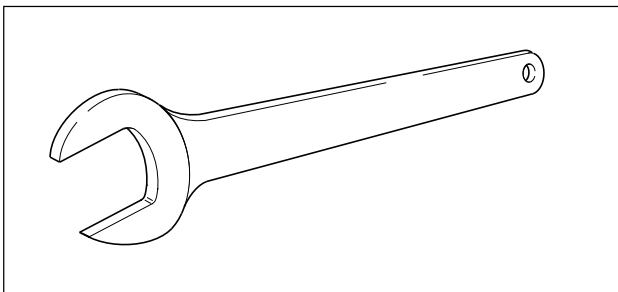

Part No. HD-41675 Oil Pressure Sending Unit Wrench

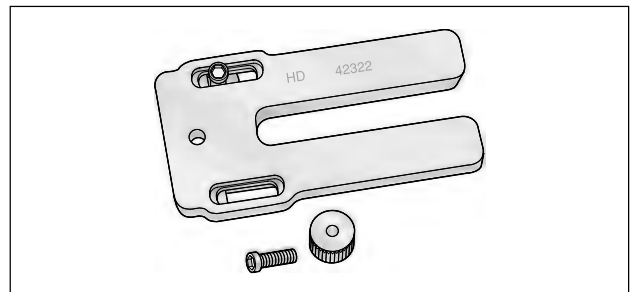

Part No. HD-42322 Piston Support Plate

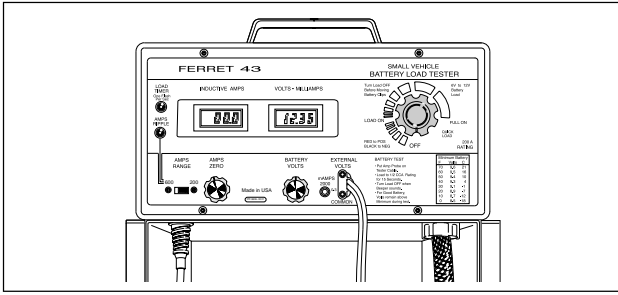

Part No. HD-42376 Battery/Charging System Load Tester

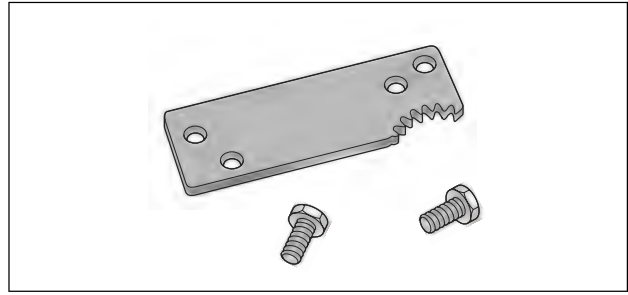

Part No. HD-43984 Crankshaft Locking Tool

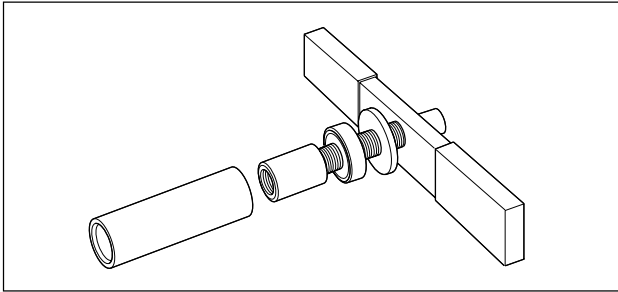

Part No. HD-42579 Sprocket Bearing/Seal Installer

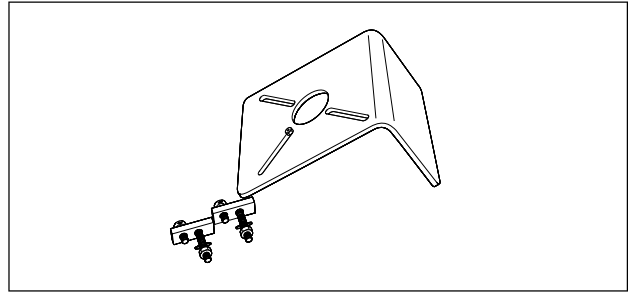

Part No. HD-44358 Flywheel Support Fixture

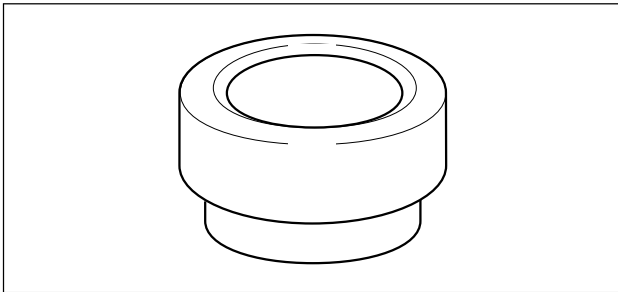

Part No. HD-42774 Sprocket Shaft Seal Installer

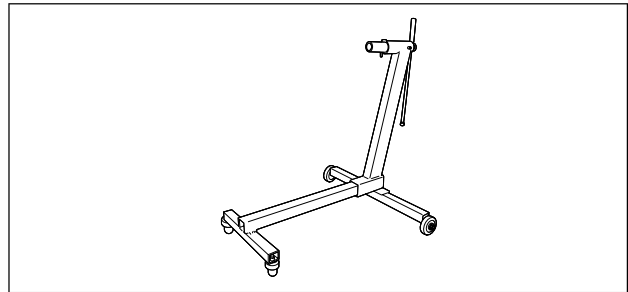

Part No. HD-43682 Rolling Engine Stand.
Use with Part No. HD-43682-10 and Part No. B-43987.

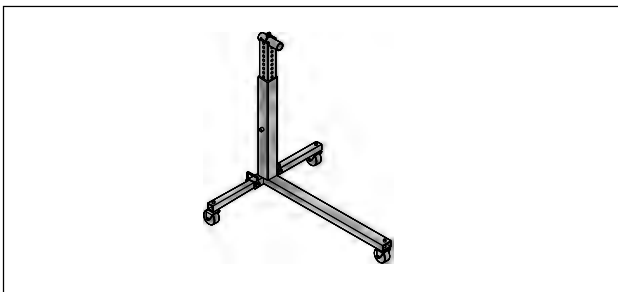

Part No. HD-43646 Engine Stand

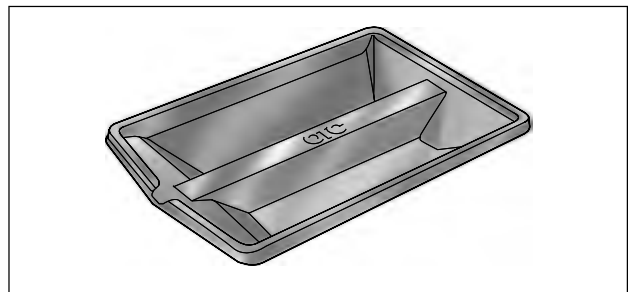

Part No. HD-43682-10 Drip pan.
Use with Part No. HD-43682 or Part No. HD-43646.

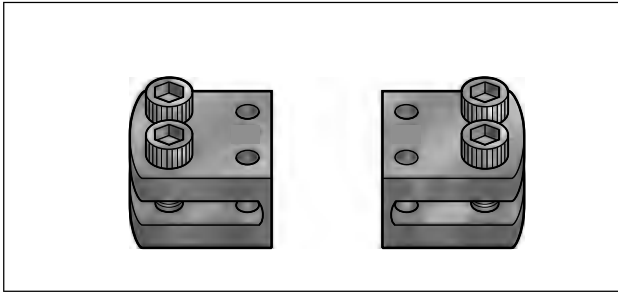

Part No. HD-44069 Timkin Snap ring remover and installer. Use with Part No. HD-44404.

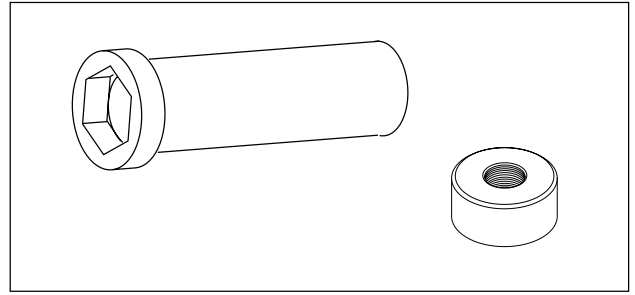

Part No. HD-94660-37B Mainshaft Locknut Wrench
Use with Part No. B-43982.

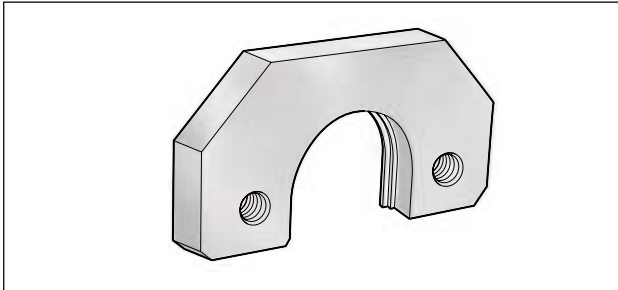

Part No. HD-44404 Timkin Bearing Remover. Use with Part No. HD-44069.

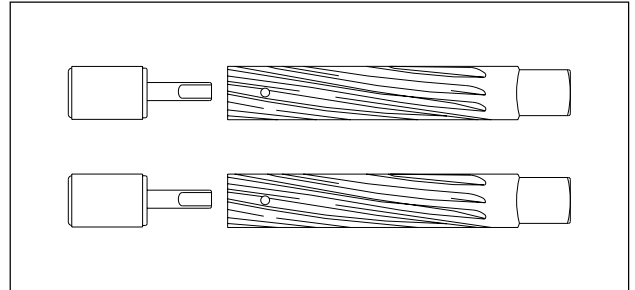

Part No. HD-94800-26A Connecting Rod Bushing Reamers and Pilots

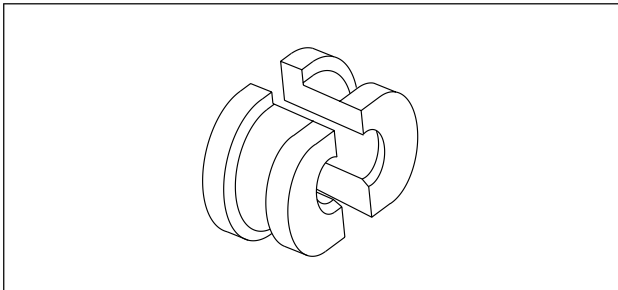

Part No. HD-94547-101 Crankshaft Bearing Outer Race Remover. Use with Part No. HD-94547-102.

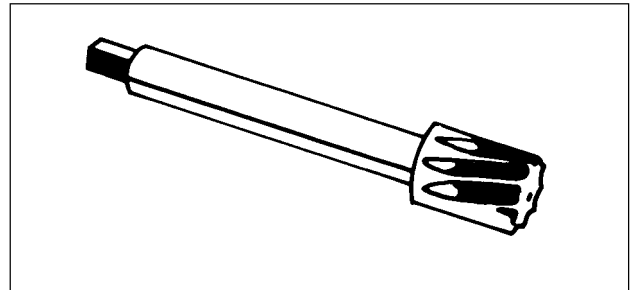

Part No. HD-94803-67 Intake Camshaft Bushing Reamer

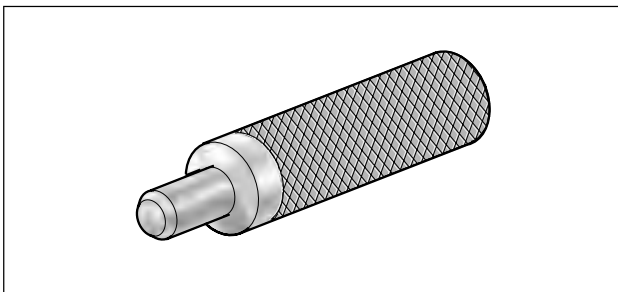

Part No. HD-94547-102 Drive Handle. Use with Part No. HD-94547-101.

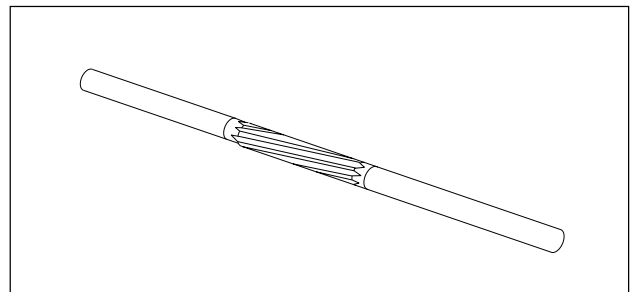

Part No. HD-94804-57 Rocker Arm Bushing Reamer

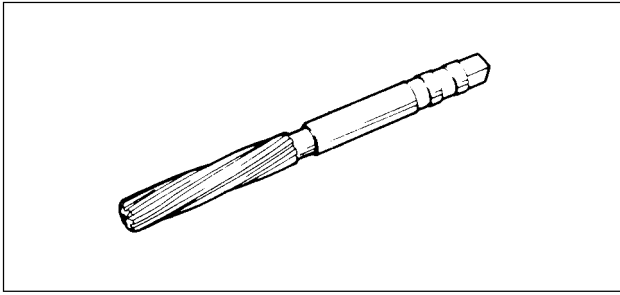

Part No. HD-94812-1 Pinion Shaft Bushing Reamer.
Use with Part No. HD-94812-87.

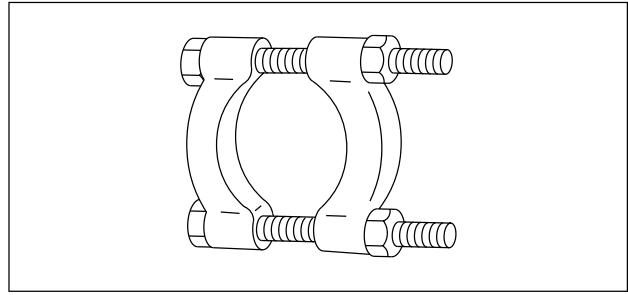
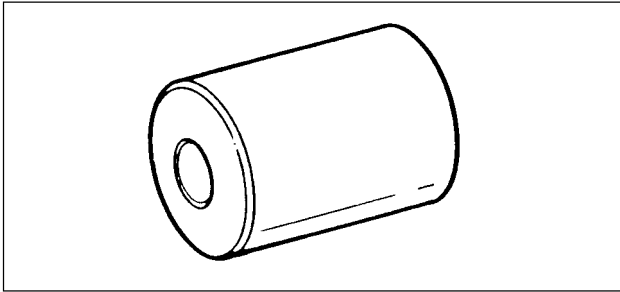
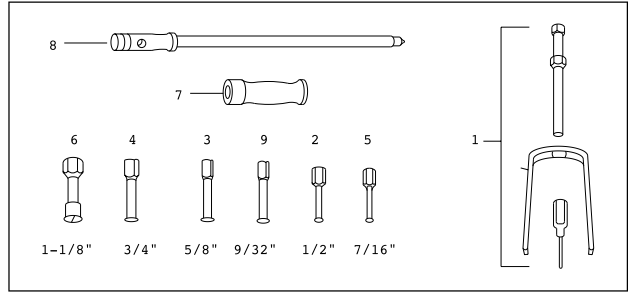

Figure 3-3. Part No. HD-95637-46A Wedge Attachment for
Claw Puller. Use with Part No. HD-95635-46.



Part No. HD-94812-87 Pinion Shaft Reamer Pilot.
Use with Part No. HD-94812-1.



Part No. HD-95760-69A Bushing/Bearing Puller Tool Set
Set includes items 1-7. Items 8 (HD-95769-69), 9 (HD-95770-69) and 10 (HD-95771-69) are optional.

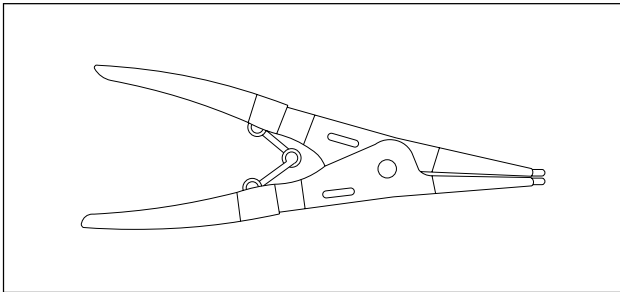

Part No. HD-95017-61 Large External Retaining
Ring Pliers

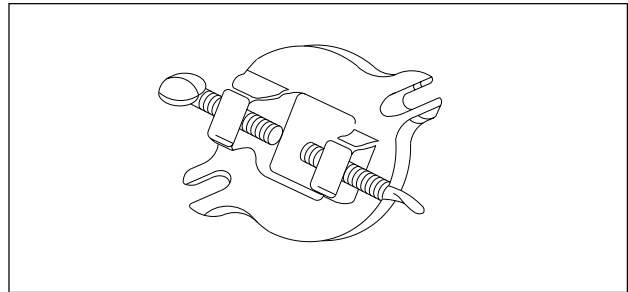

Part No. HD-95952-33B Connecting Rod
Clamping Tool

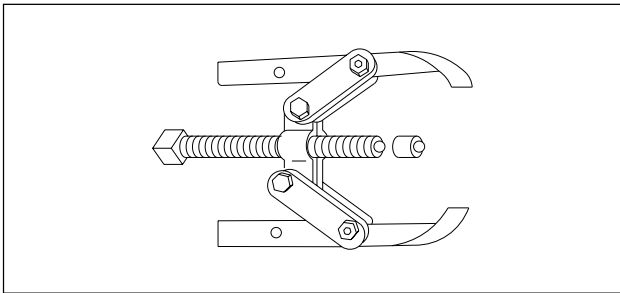

Part No. HD-95635-46 All-Purpose Claw Puller

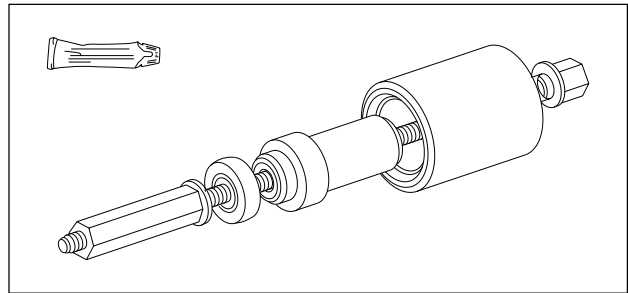

Part No. HD-95970-32D Piston Pin Bushing Tool

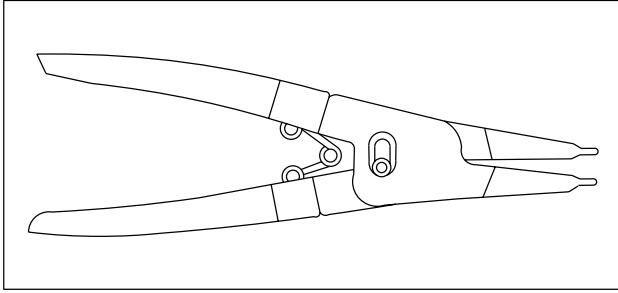

Part No. HD-96215-49 Small Internal Retaining Ring Pliers

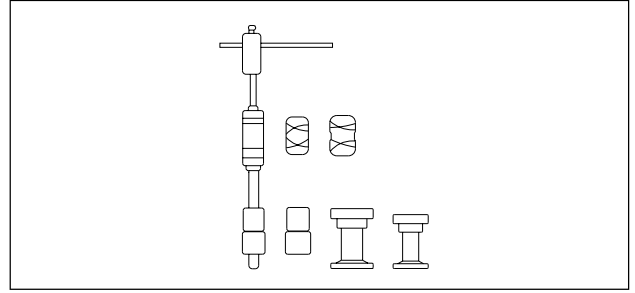

Part No. HD-96710-40B Crankcase Main Bearing Lapping Tool

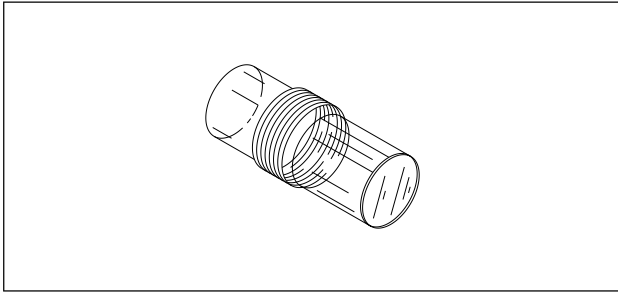

Part No. HD-96295-65D Timing Mark View Plug.
Use with Part No. HD-33813.

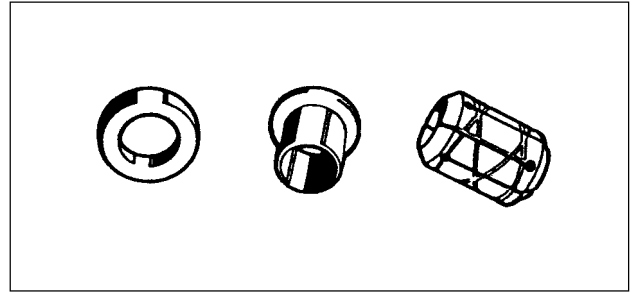

Part No. HD-96718-87 Pinion Bearing Outer Race Lapping Kit

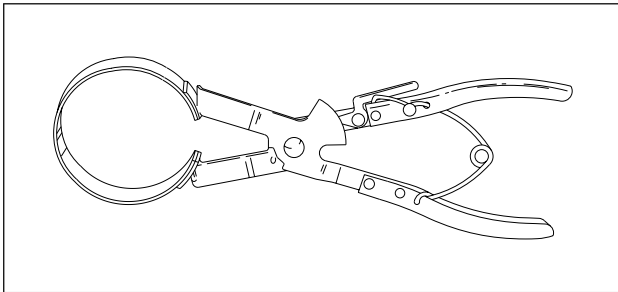

Part No. HD-96333-51C Piston Ring Compressor

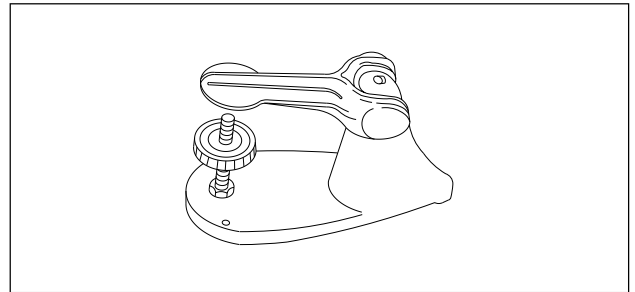

Part No. HD-96796-47 Valve Spring Tester

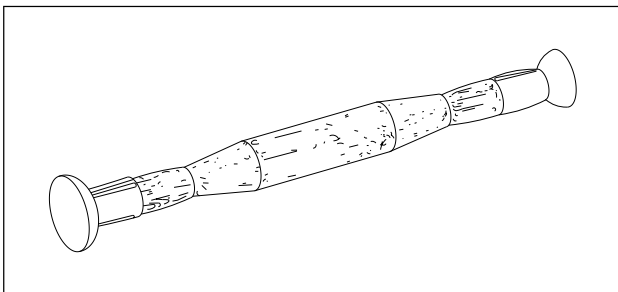

Part No. HD-96550-36A Valve Lapping Tool

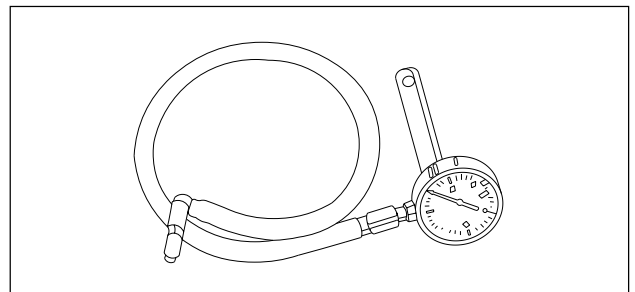

Part No. HD-96921-52B Oil Pressure Gauge

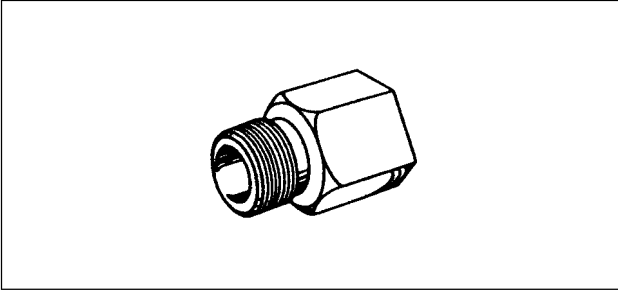

Part No. HD-96921-58 Oil Pressure Gauge Adapter.
Use with Part No. HD-96921-52B.

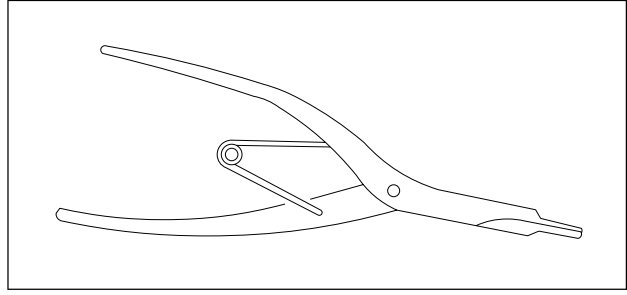

Part No. J-5586 Transmission Shaft
Retaining Ring Pliers

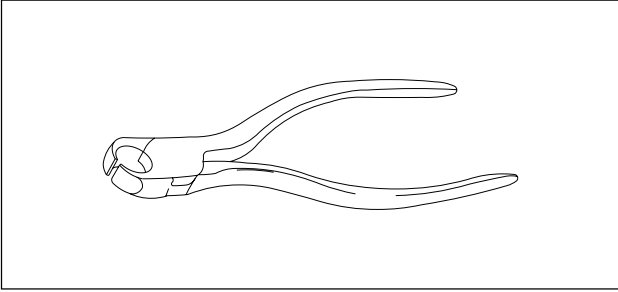

Part No. HD-97087-65B Hose Clamp Pliers

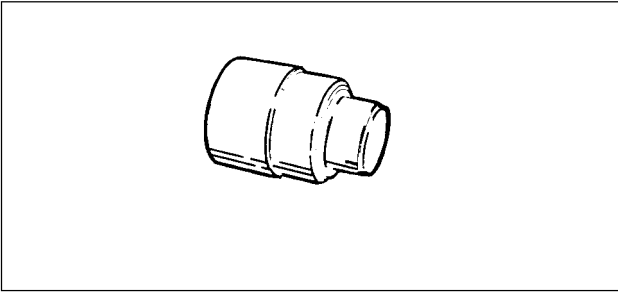

Part No. HD-97273-60 Camshaft Bushing Installer

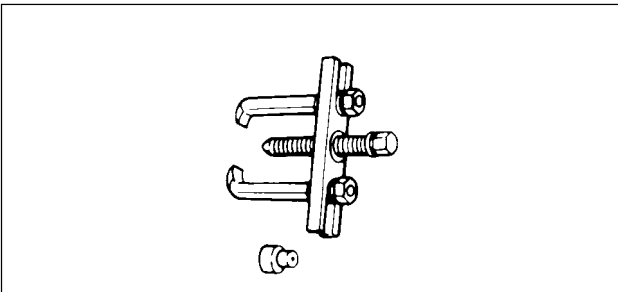

Part No. HD-97292-61 Two Claw Puller

GENERAL

NOTE

The following table provides a description of the connectors found on your motorcycle.

*Male ends of connectors are labeled "A" in text.
Female ends of connectors are labeled "B" in text.*

Connector numbers are listed in [brackets] in this manual.

Table B-1. Electrical Connectors

CONNECTOR	DESCRIPTION	COMPONENT(S)	LOCATION
[7]	6-place Amp Multilock	Tail Lamp/Rear Directionals	Under Seat
[10]	6-place Deutsch	Integrated Ignition Module Sensor	Left side of frame backbone on T-stud
[22]	4-place Amp Multilock	Right Handlebar Switch Housing-ignition power, module and starter	Behind windscreen
[20]	12-place Deutsch	Indicators/Speedometer	Behind windscreen
[24]	10-place Amp Multilock	Left Handlebar Switch Housing-turn signals, lights	Behind windscreen
[30]	3-blade relay connector	Flasher Relay	Under seat, to right of battery
[33]	4-place Deutsch	Ignition/Headlamp Key Switch	Behind windscreen
[38]	4-place Amp Multilock	Headlamp	Behind windscreen/headlamp
[39]	12-place Packard	Speedometer/Indicators	On back of speedometer
[46]	2-place barrel connector	Voltage Regulator	Above swingarm, left side
[60]	2-place Amp Multilock	Side Stand Switch	On top of swingarm, cable tied to rear brake line
[61]	9-slot fuse block	Fuse Block	Under seat on right side
[65]	3-place Deutsch	Speed Sensor	Under seat, to right of shock
[83]	3-place Amp Multilock	Ignition Coil	Under frame backbone at coil
[88]	6-place Deutsch	Throttle Position Sensor and Auto-Enrichener	Under frame backbone, right side
[95]	2-place Amp Multilock	Clutch Switch	At left handlebar
[120]	Post	Oil Pressure Switch	Above oil filter, right lower side of crankcase
[121]	2 blades	Rear Stoplight Switch	At switch, under frame by shock absorber
[122]	Blade	Horn	At horn, behind front fork
[123]	4-blade relay connector	Starter Relay	Under seat to right of battery
[128]	Blade	Starter	Under starter solenoid
[131]	Post	Neutral Switch	Behind sprocket cover, right side
[134]	3-place Packard	Bank Angle Sensor	Under Seat to right of battery
[170]	2 blades	Front Brake Switch	At right handlebar switch
[171]	4-blade relay connector	System Relay	Under seat, to left of battery
[172]	1-Place Bullet	Neutral Switch to main harness	Above sprocket cover, right side

GENERAL

The Deutsch Connector features a seal to protect electrical contacts from dirt and moisture.

Three and eight pin connectors are of similar construction with one exception: eight pin connectors use two external latches on the socket side.

NOTE

Use the *DEUTSCH TERMINAL CRIMP TOOL* (Part No. HD-39965) to install Deutsch pin and socket terminals on wires. If **new** terminals must be installed, follow the instructions included with the crimping tool or see [CRIMPING INSTRUCTIONS](#).

REMOVING/INSTALLING SOCKETS

1. See [Figure B-1](#). Remove the secondary locking wedge (6). Insert the blade of a small screwdriver between the socket housing and locking wedge in—line with the groove (in—line with the pin holes if the groove is absent). Turn the screwdriver 90° to pop the wedge up.
2. Gently depress terminal latches inside socket housing (3) and back out socket terminals (1) through holes in rear wire seal (2).
3. Fit rear wire seal (2) into back of socket housing, if removed. Grasp socket terminal approximately 1.0 in. (25.4 mm) behind the contact barrel. Gently push sockets through holes in wire seal into their respective chambers. Feed socket into chamber until it “clicks” in place. Verify that socket will not back out of chamber; a slight tug on the wire will confirm that it is properly locked in place.
4. Install internal seal (5) on lip of socket housing, if removed. Insert tapered end of secondary locking wedge (6) into socket housing and press down until it snaps in place. The wedge fits into the center groove within the socket housing and holds the terminal latches tightly closed.

NOTE

- The conical secondary locking wedge of the 3-pin connector must be installed with the arrow pointing toward the external latch. See [Figure B-2](#).
- If the secondary locking wedge does not slide into the installed position easily, verify that all terminals are fully installed in the socket housing. The lock indicates when terminals are not properly installed by not entering its fully installed position.

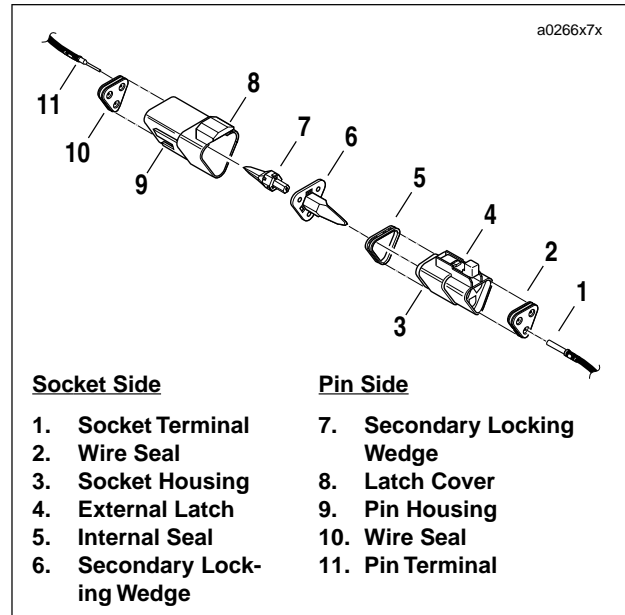

Figure B-1. 3-Pin Connector

REMOVING/INSTALLING PINS

1. See [Figure B-1](#). Remove the secondary locking wedge (7). Use the hooked end of a stiff piece of mechanic's wire or a needle nose pliers, whichever is most suitable.
2. Gently depress terminal latches inside pin housing (9) and back out pin terminals (11) through holes in wire seal (10).
3. Fit wire seal (10) into back of pin housing (9). Grasp crimped pin approximately 1.0 in. (25.4 mm) behind the contact barrel. Gently push pins through holes in wire seal into their respective numbered locations. Feed pin into chamber until it “clicks” in place. Verify that pin will not back out of chamber; a slight tug on the wire will confirm that it is properly locked in place.
4. Insert tapered end of secondary locking wedge (7) into pin housing (9) and press down until it snaps in place. The wedge fits in the center groove within the pin housing and holds the terminal latches tightly closed.

ASSEMBLY/INSTALLATION

Insert socket housing (3) into pin housing (9) until it snaps in place. To fit the halves of the connector together, the latch (4) on the socket side must be aligned with the latch cover (8) on the pin side.

CRIMPING INSTRUCTIONS

1. See [Figure B-3](#). Squeeze the handles to cycle the *DEUTSCH TERMINAL CRIMP TOOL* (Part No. HD-39965) to the fully open position.

2. Raise locking bar by pushing up on bottom flange. With the crimp tails facing upward and the rounded side of the contact barrel resting on the concave split level area of the crimp tool, insert contact (socket/pin) through middle hole of locking bar.
3. Release locking bar to lock position of contact. If the crimp tails are slightly out of vertical alignment, the crimp tool automatically rotates the contact so that the tails face straight upward. When correctly positioned, the locking bar fits snugly in the space between the contact band and the core crimp tails.
4. Strip lead removing 0.1562 in. (4.0 mm) of insulation. Insert wires between crimp tails until ends make contact with locking bar. Verify that wire is positioned so that short pair of crimp tails squeeze bare wire strands, while long pair folds over insulation material.
5. Squeeze handle of crimp tool until tightly closed. Tool automatically opens when the crimping sequence is complete. Raise up locking bar and remove contact.

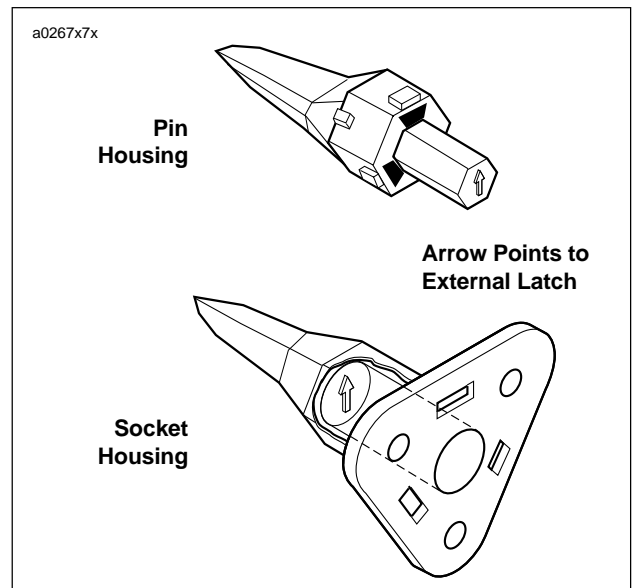

Figure B-2. 3-pin Locking Wedge Orientation

NOTE

Inspect the quality of the core and insulation crimps. Distortion should be minimal.

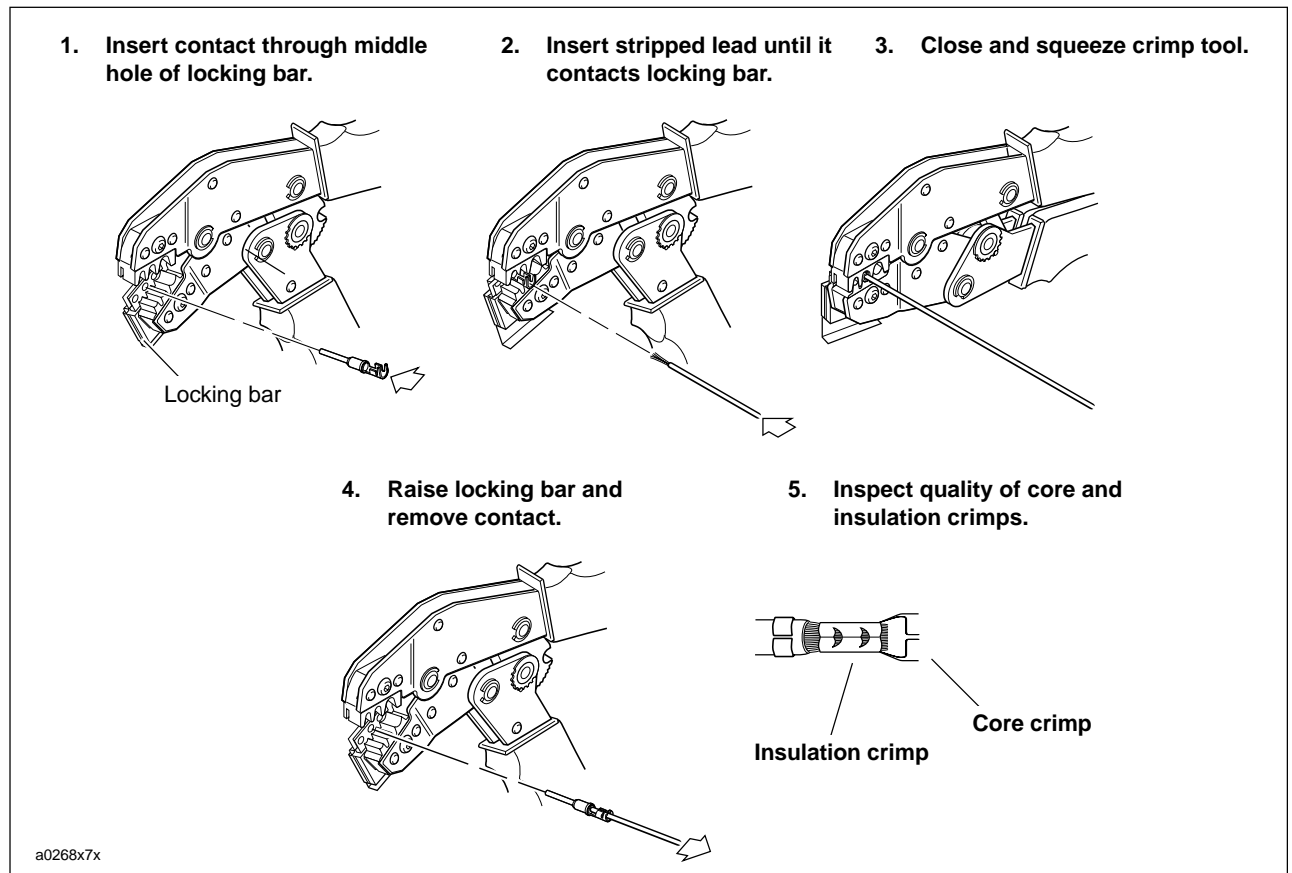

Figure B-3. Deutsch Crimping Procedure

REMOVING SOCKET/PIN TERMINALS

1. If necessary, cut any surrounding cable straps to gain access to the connector.
2. See [Figure B-4](#). Depress the button (5) on the socket housing (3).
3. Pull apart the pin and socket halves.
4. Bend back the latch slightly and free one side of secondary lock, then repeat the step to release the other side.
5. Rotate the secondary lock outward on hinge to access terminals in chambers of connector housing.
6. Looking in the terminal side of the connector (opposite the secondary lock), take note of the cavity next to each terminal.
7. Remove socket terminal ([Figure B-6](#)) or pin terminal ([Figure B-7](#))
 - a. With the flat edge against the terminal, insert the pick (Snap-On TT600-3) into the cavity until it stops.
 - b. Pivot the end of the pick away from the terminal to release the tang.
 - c. Gently tug on wire to pull terminal from chamber. Do not tug on the wire until the tang is released or the terminal will be difficult to remove. A “click” is heard if the tang is engaged but then inadvertently released. Repeat the steps without releasing the tang.

NOTE

An AMP TERMINAL CRIMP TOOL (Part No. HD-41609) is used to install Amp Multi-lock pin and socket terminals on wires. If **new** terminals must be installed, see [CRIMPING INSTRUCTIONS](#).

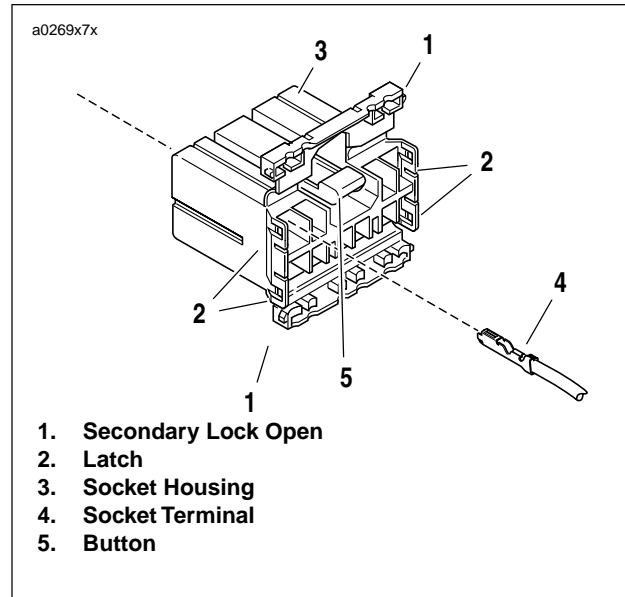

Figure B-4. Socket Housing

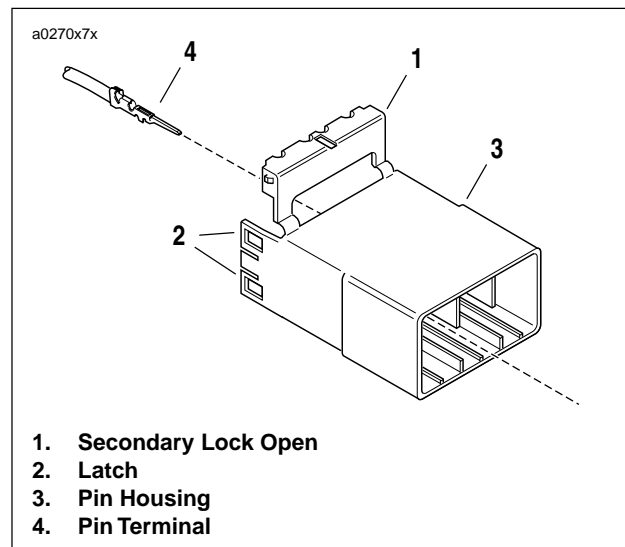

Figure B-5. Pin Housing

INSTALLING SOCKET/PIN TERMINALS

NOTES

- For wire location purposes, numbers are stamped into the secondary locks of both the socket and pin housings.
 - The tang in the chamber engages the slot to lock the terminal in position.
 - On the pin side of the connector, tangs are positioned at the bottom of each chamber, so the slot in the pin terminal (on the side opposite the crimp tails) must face downward.
 - On the socket side, tangs are at the top of each chamber, so the socket terminal slot (on the same side as the crimp tails) must face upward.
 - Up and down can be determined by the position of the release button (used to separate the pin and socket halves), the button always being the top of the connector.
1. From the secondary lock side of the connector, insert the terminal into its respective numbered chamber until it snaps in place. For proper fit, the slot in the terminal must face the tang in the chamber.
 - a. If installing socket terminals, see [Figure B-6](#).
 - b. If installing pin terminals, see [Figure B-7](#).
 2. Gently tug on wire end to verify that the terminal is locked in place and will not back out of chamber.
 3. Rotate the hinged secondary lock inward until tabs fully engage latches on both sides of connector.
 4. Insert the socket housing (plug) into the pin housing (receptacle) until it snaps in place.
 5. Secure wiring harness with **new** cable straps.

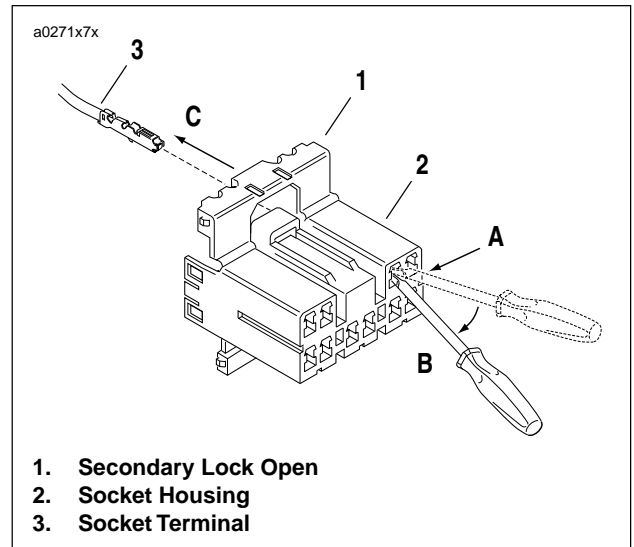

Figure B-6. Socket Terminals

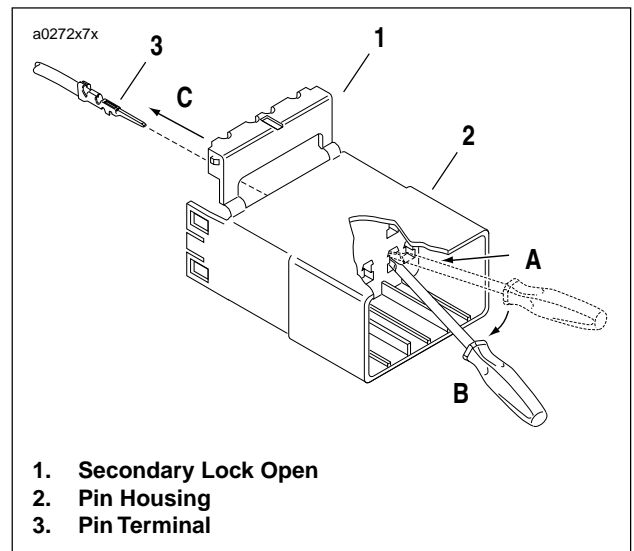

Figure B-7. Pin Terminals

CRIMPING INSTRUCTIONS

1. See [Figure B-9](#). Squeeze the handles to cycle the AMP TERMINAL CRIMP TOOL (Part No. HD-41609) to the fully open position.
2. Raise locking bar by pushing up on bottom flange. With the crimp tails facing upward, insert contact (socket/pin) through locking bar, so that the closed side of the contact rests on the nest (concave split level area) of the crimp tool). Use the front nest for 20 gauge wire, the middle for 16 gauge and the rear for 18 gauge.
3. Release locking bar to lock position of contact. When correctly positioned, the locking bar fits snugly in the space at the front of the core crimp tails.
4. Strip lead removing 0.1562 in. (4.0 mm) of insulation. Insert wires between crimp tails until ends make contact with locking bar. Verify that wire is positioned so that short pair of crimp tails squeeze bare wire strands, while long pair folds over insulation material.
5. Squeeze handle of crimp tool until tightly closed. Tool automatically opens when the crimping sequence is complete. Raise up locking bar and remove contact.
6. See [Figure B-8](#). Inspect the quality of the core and insulation crimps. Distortion should be minimal.

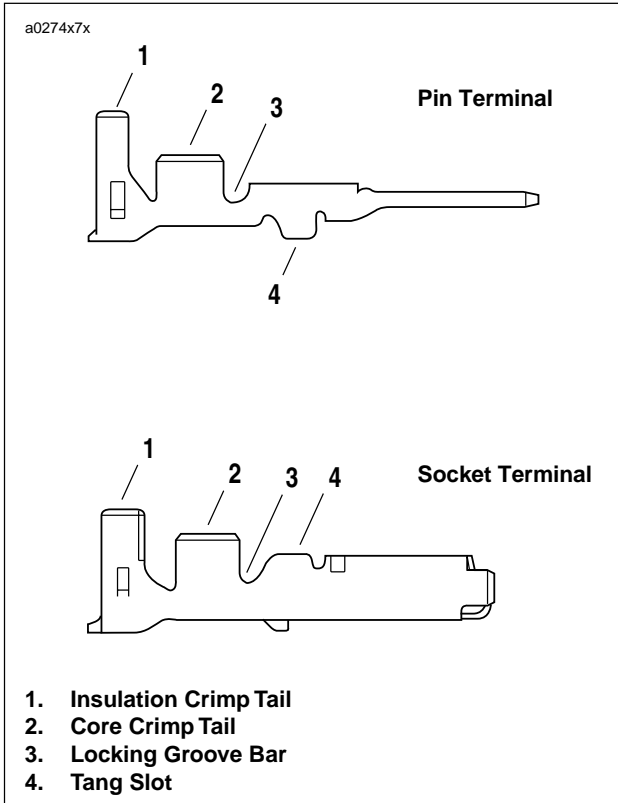

Figure B-8. Crimps

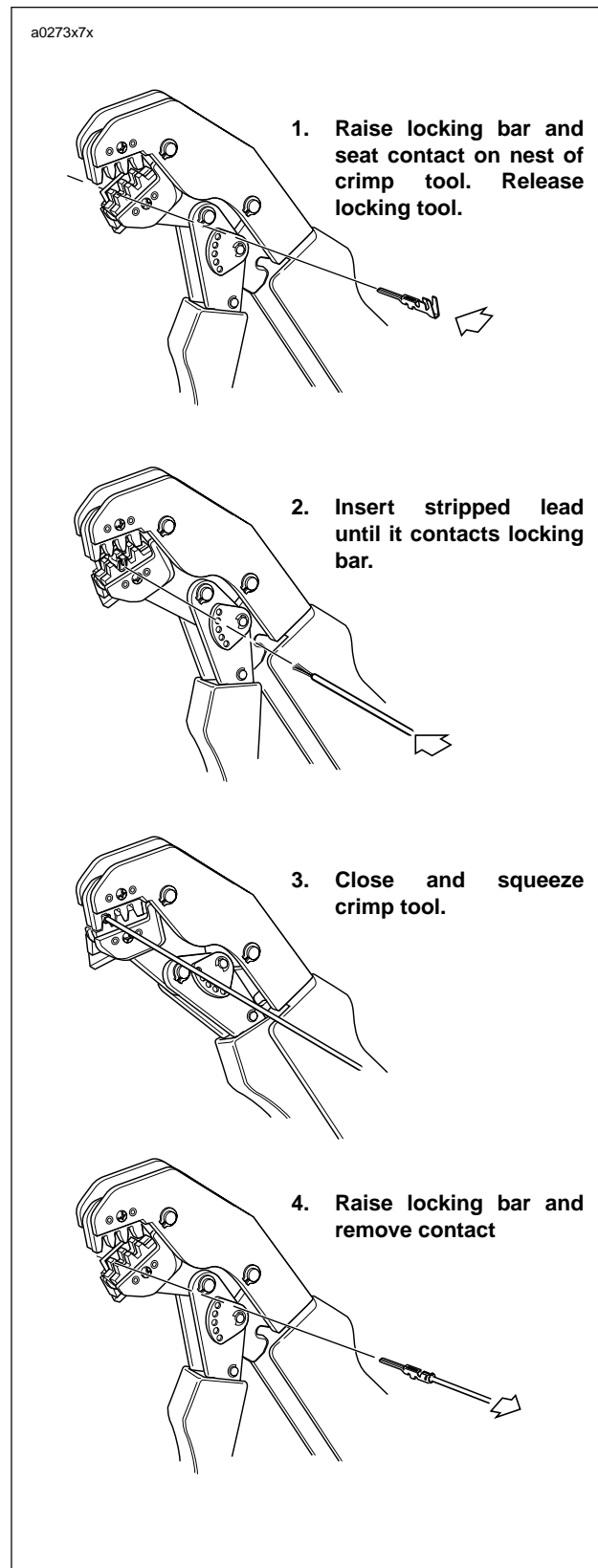

Figure B-9. Amp Multilock Crimping Procedure

a0280a7x

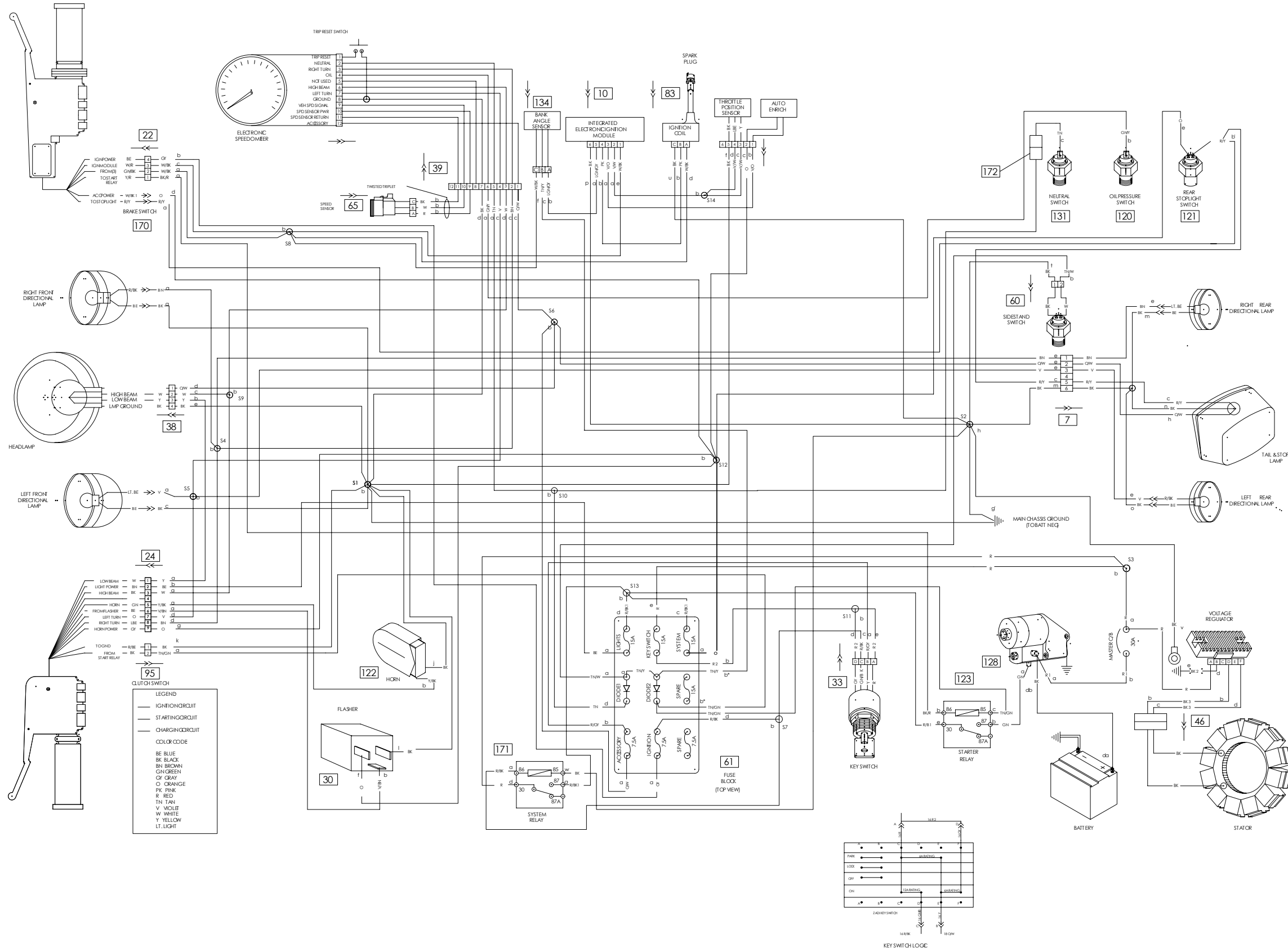

Figure B-10. 2001 Buell Blast P3 Model - Main Harness

a0194x5x

COLOR CODE :	
LT.	LIGHT
BK	BLACK
BE	BLUE
BN	BROWN
GN	GREEN
GY	GRAY
O	ORANGE
PK	PINK
R	RED
TN	TAN
V	VIOLET
W	WHITE
Y	YELLOW

CONNECTOR CODE :	
	DIODE
	PIN CONNECTOR
	SOCKET CONNECTOR
	SPLICE CONNECTION
	NO CONNECTION

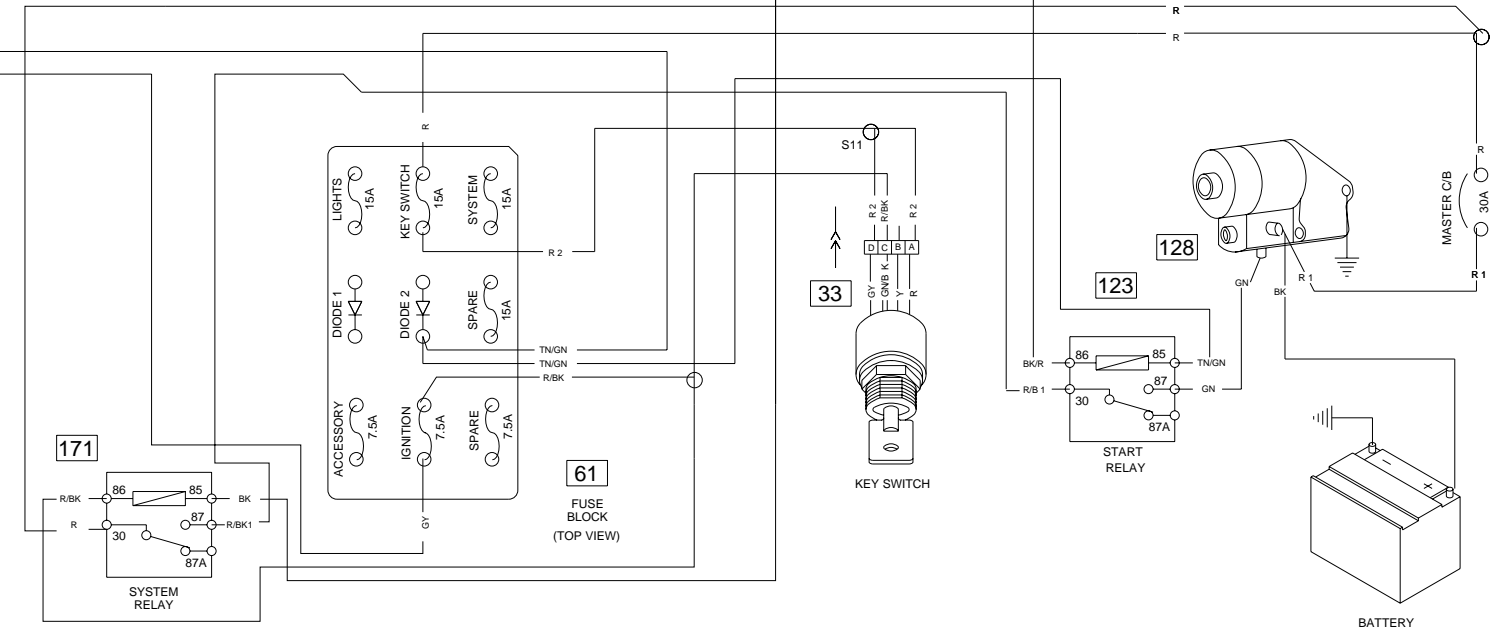
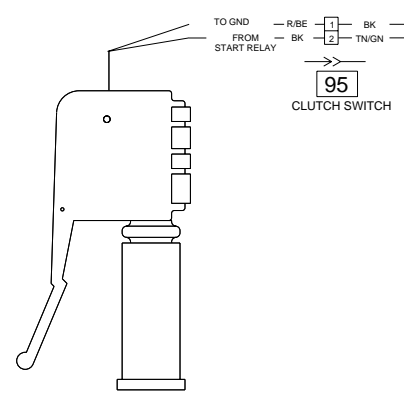
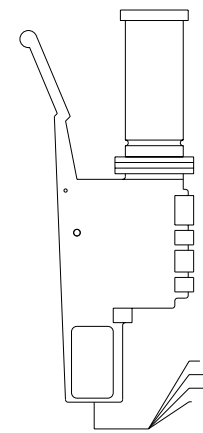
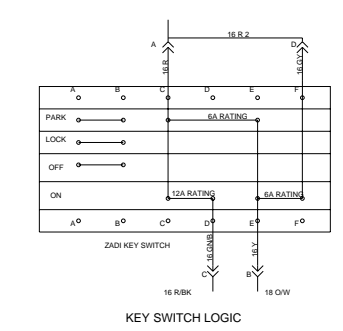

Figure B-11. 2001 Buell Blast P3 Model - Starting

a0278x7x

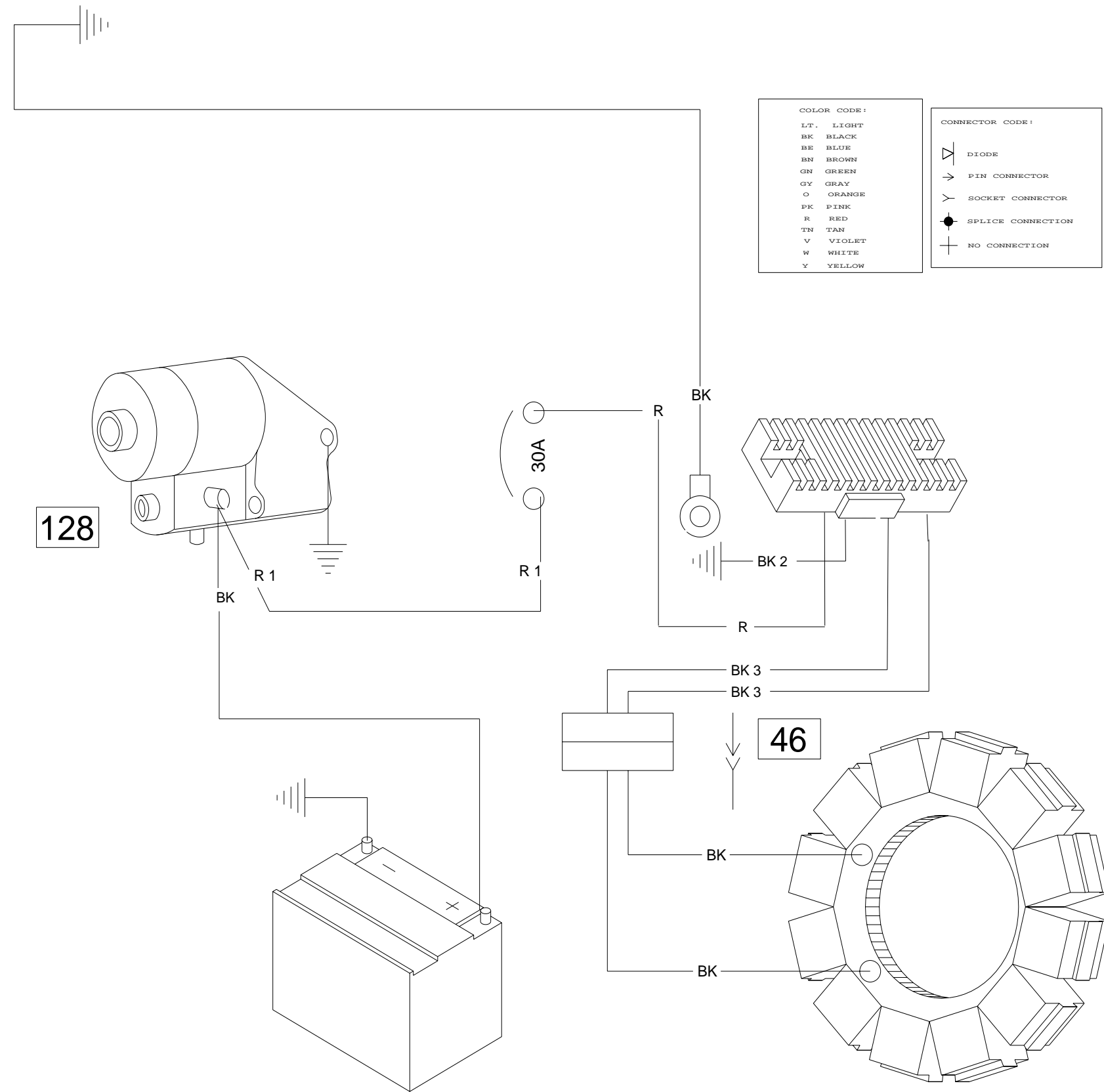

Figure B-12. 2001 Buell Blast P3 Model - Charging

a0279x7x

COLOR CODE:

LT.	LIGHT
BK	BLACK
BE	BLUE
BN	BROWN
GN	GREEN
GY	GRAY
O	ORANGE
PK	PINK
R	RED
TN	TAN
V	VIOLET
W	WHITE
Y	YELLOW

CONNECTOR CODE:

	DIODE
	PIN CONNECTOR
	SOCKET CONNECTOR
	SPLICE CONNECTION
	NO CONNECTION

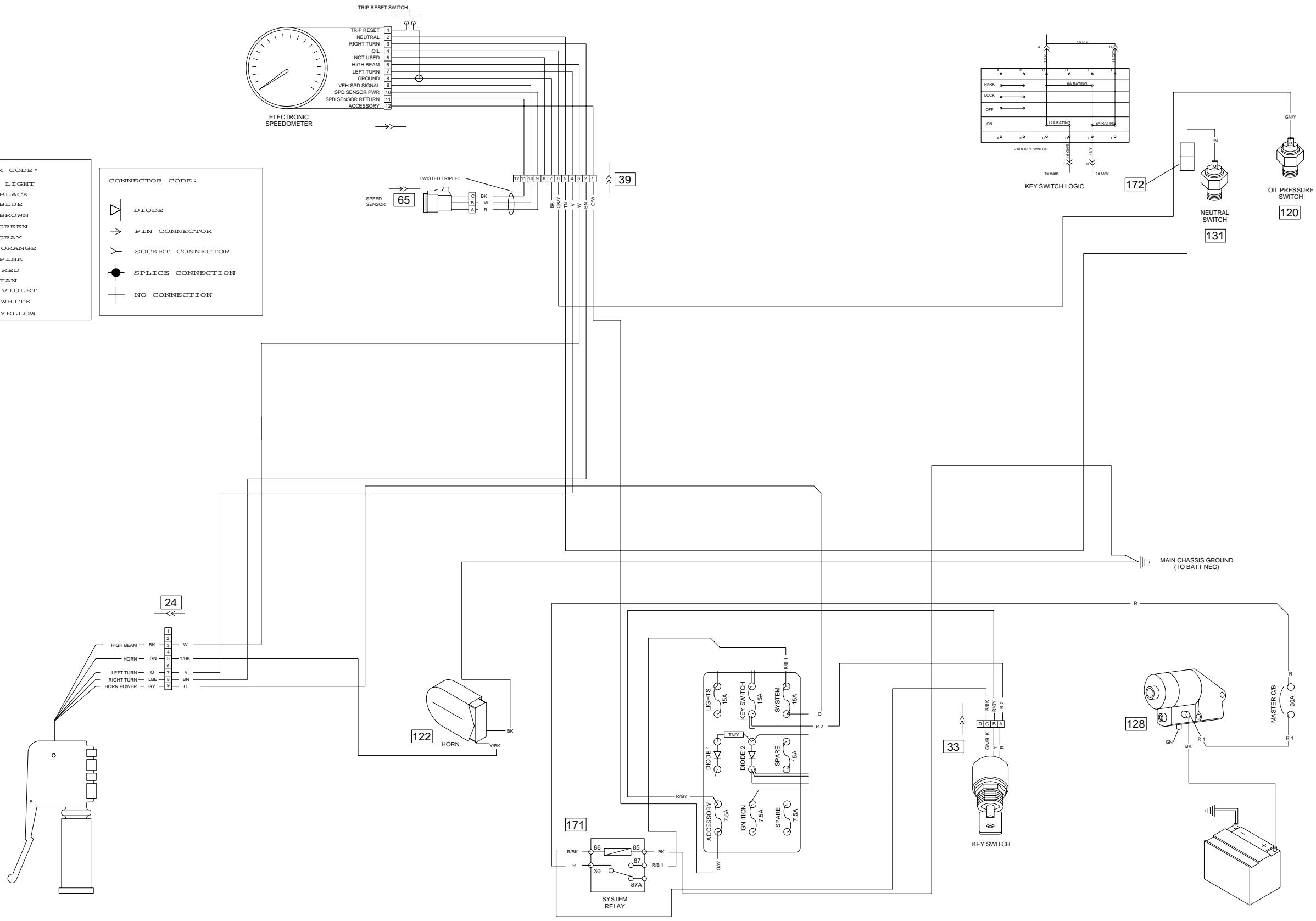

Figure B-13. 2001 Buell Blast P3 Model - Horn and Instruments

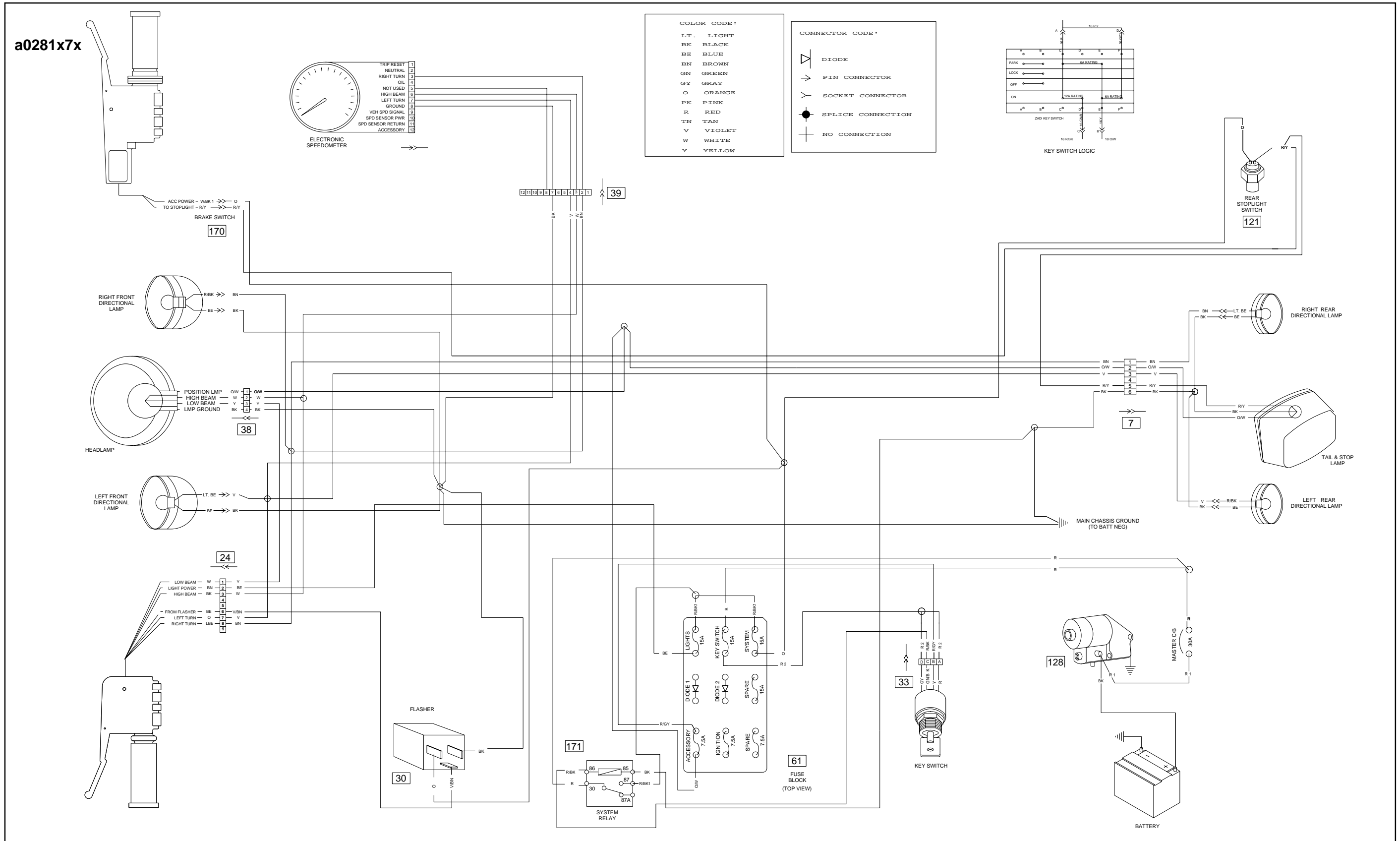

Figure B-14. 2001 Buell Blast P3 Model - Lighting

a0282a7x

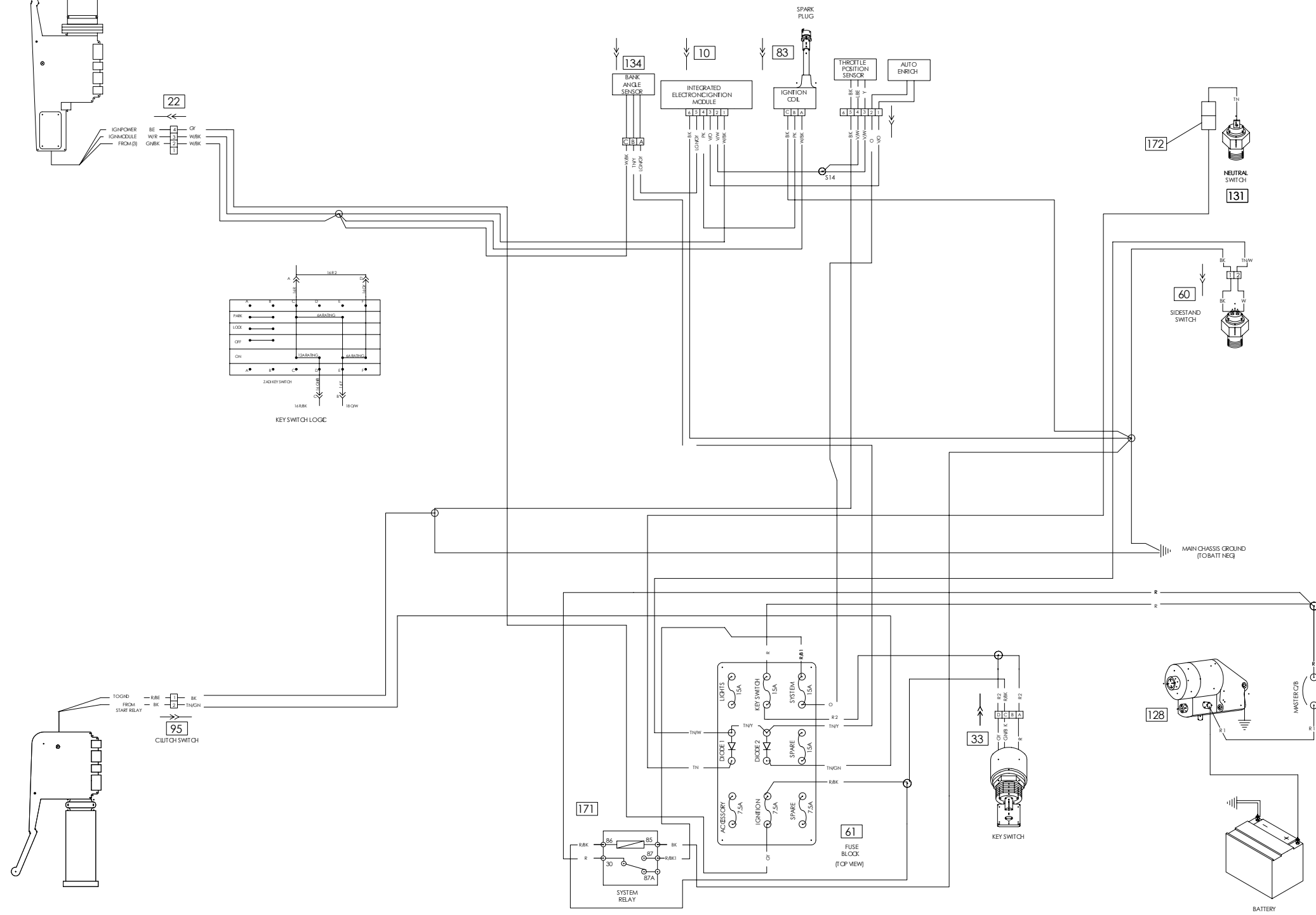

Figure B-15. 2001 Buell Blast P3 Model - Ignition

METRIC CONVERSIONS

C.1







MILLIMETERS TO INCHES (MM X 0.03937 = INCHES)								INCHES TO MILLIMETERS (INCHES X 25.40 = MM)							
mm	in.	mm	in.	mm	in.	mm	in.	in.	mm	in.	mm	in.	mm	in.	mm
.1	.0039	25	.9842	58	2.283	91	3.582	.001	.025	.6	15.240	1 ^{15/16}	49.21	3 ^{5/16}	84.14
.2	.0078	26	1.024	59	2.323	92	3.622	.002	.051	5/8	15.875	2	50.80	3 ^{3/8}	85.72
.3	.0118	27	1.063	60	2.362	93	3.661	.003	.076	1 ^{1/16}	17.462	2 ^{1/16}	52.39	3.4	86.36
.4	.0157	28	1.102	61	2.401	94	3.701	.004	.102	.7	17.780	2.1	53.34	3 ^{7/16}	87.31
.5	.0197	29	1.142	62	2.441	95	3.740	.005	.127	3/4	19.050	2 ^{1/8}	53.97	3 ^{1/2}	88.90
.6	.0236	30	1.181	63	2.480	96	3.779	.006	.152	.8	20.320	2 ^{3/16}	55.56	3 ^{9/16}	90.49
.7	.0275	31	1.220	64	2.519	97	3.819	.007	.178	13/16	20.638	2.2	55.88	3.6	91.44
.8	.0315	32	1.260	65	2.559	98	3.858	.008	.203	7/8	22.225	2 ^{1/4}	57.15	3 ^{5/8}	92.07
.9	.0354	33	1.299	66	2.598	99	3.897	.009	.229	.9	22.860	2.3	58.42	3 ^{11/16}	93.66
1	.0394	34	1.338	67	2.638	100	3.937	.010	.254	15/16	23.812	2 ^{5/16}	58.74	3.7	93.98
2	.0787	35	1.378	68	2.677	101	3.976	1/64	.397	1	25.40	2 ^{3/8}	60.32	3 ^{3/4}	95.25
3	.1181	36	1.417	69	2.716	102	4.016	.020	.508	1 ^{1/16}	26.99	2.4	60.96	3.8	96.52
4	.1575	37	1.456	70	2.756	103	4.055	.030	.762	1.1	27.94	2 ^{7/16}	61.91	3 ^{13/16}	96.84
5	.1968	38	1.496	71	2.795	104	4.094	1/32	.794	1 ^{1/8}	28.57	2 ^{1/2}	63.50	3 ^{7/8}	98.42
6	.2362	39	1.535	72	2.834	105	4.134	.040	1.016	1 ^{3/16}	30.16	2 ^{9/16}	65.09	3.9	99.06
7	.2756	40	1.575	73	2.874	106	4.173	.050	1.270	1.2	30.48	2.6	66.04	3 ^{15/16}	100.01
8	.3149	41	1.614	74	2.913	107	4.212	.060	1.524	1 ^{1/4}	31.75	2 ^{5/8}	66.67	4	101.6
9	.3543	42	1.653	75	2.953	108	4.252	1/16	1.588	1.3	33.02	2 ^{11/16}	68.26	4 ^{1/16}	102.19
10	.3937	43	1.693	76	2.992	109	4.291	.070	1.778	1 ^{5/16}	33.34	2.7	68.58	4.1	104.14
11	.4331	44	1.732	77	3.031	110	4.331	.080	2.032	1 ^{3/8}	34.92	2 ^{3/4}	69.85	4 ^{1/8}	104.77
12	.4724	45	1.772	78	3.071	111	4.370	.090	2.286	1.4	35.56	2.8	71.12	4 ^{3/16}	106.36
13	.5118	46	1.811	79	3.110	112	4.409	.1	2.540	1 ^{7/16}	36.51	2 ^{13/16}	71.44	4.2	106.68
14	.5512	47	1.850	80	3.149	113	4.449	1/8	3.175	1 ^{1/2}	38.10	2 ^{7/8}	73.02	4 ^{1/4}	107.95
15	.5905	48	1.890	81	3.189	114	4.488	3/16	4.762	1 ^{9/16}	39.69	2.9	73.66	4.3	109.22
16	.6299	49	1.929	82	3.228	115	4.527	.2	5.080	1.6	40.64	2 ^{15/16}	74.61	4 ^{5/16}	109.54
17	.6693	50	1.968	83	3.268	116	4.567	1/4	6.350	1 ^{5/8}	41.27	3	76.20	4 ^{3/8}	111.12
18	.7086	51	2.008	84	3.307	117	4.606	.3	7.620	1 ^{11/16}	42.86	3 ^{1/16}	77.79	4.4	111.76
19	.7480	52	2.047	85	3.346	118	4.645	5/16	7.938	1.7	43.18	3.1	78.74	4 ^{7/16}	112.71
20	.7874	53	2.086	86	3.386	119	4.685	3/8	9.525	1 ^{3/4}	44.45	3 ^{1/8}	79.37	4 ^{1/2}	114.30
21	.8268	54	2.126	87	3.425	120	4.724	.4	10.160	1.8	45.72	3 ^{3/16}	80.96	4 ^{9/16}	115.89
22	.8661	55	2.165	88	3.464	121	4.764	7/16	11.112	1 ^{13/16}	46.04	3.2	81.28	4.6	116.84
23	.9055	56	2.205	89	3.504	122	4.803	1/2	12.700	1 ^{7/8}	47.62	3 ^{1/4}	82.55	4 ^{5/8}	117.47
24	.9449	57	2.244	90	3.543	123	4.842	9/16	14.288	1.9	48.26	3.3	83.82	4 ^{11/16}	119.06

Torque specifications for specific components are listed in each section at the point of use. When converting to Newton-meters, use the formulas given under the metric chart. For all other steel fasteners, use the values listed in one of the tables below. In the English table, torque figures are listed in ft-lbs, except those marked with an asterisk (*), which are listed in **in-lbs**. In the metric table, figures are listed in Newton-meters.

⚠ WARNING







The quality fasteners used on Buell motorcycles have specific strength, finish and type requirements to perform properly in the assembly and the operating environment. Use only genuine Buell replacement fasteners tightened to the proper torque. Substitution could cause fastener failure, which could result in death or serious injury.

English Torque Values

FASTENER	TYPE	MINIMUM TENSILE STRENGTH	MATERIAL	BODY SIZE OR OUTSIDE DIAMETER																	
				# (number)								in. (inches)									
				2	3	4	5	6	8	10	1/4	5/16	3/8	7/16	1/2	9/16	5/8	3/4	7/8	1	
	SAE 2 STEEL	74,000 PSI	LOW CARBON									6	12	20	32	47	69	96	155	206	310
	SAE 5 STEEL	120,000 PSI	MEDIUM CARBON HEAT TREAT						14*	22*		10	19	33	54	78	114	154	257	382	587
	SAE 7 STEEL	133,000 PSI	MEDIUM CARBON ALLOY									13	25	44	71	110	154	215	360	570	840
	SAE 8 STEEL	150,000 PSI	MEDIUM CARBON ALLOY									14	29	47	78	119	169	230	380	600	900
	SAE 8 STEEL	150,000 PSI	MEDIUM CARBON ALLOY									14	29	47	78	119	169	230	380	600	900
	SOCKET SET SCREW	212,000 PSI	HIGH CARBON QUENCHED TEMPERED					9*	16*	30*	70*	140*	18	29	43	63	100	146			
	STUDS			Use SAE 2, 5 and 8 values when grade is known, with nut of sufficient strength.																	

*Torque values in **in-lbs**.

Metric Torque Values

FASTENER	TYPE	MINIMUM TENSILE STRENGTH	MATERIAL	BODY SIZE OR OUTSIDE DIAMETER																		
				# (number)								mm (millimeters)										
				2	3	4	5	6	8	10	6.4	7.9	9.5	11.1	12.7	14.3	15.9	19.1	22.2	25.4		
	SAE 2 STEEL	5,202 kg/cm ²	LOW CARBON										8.3	16.6	27.7	44.3	65.0	95.4	132.8	214.4	283.5	428.7
	SAE 5 STEEL	8,436 kg/cm ²	MEDIUM CARBON HEAT TREAT						1.6	2.5		13.8	26.3	45.6	74.7	107.9	157.7	213.0	355.4	528.3	811.8	
	SAE 7 STEEL	9,350 kg/cm ²	MEDIUM CARBON ALLOY									18.0	34.6	60.8	98.2	152.1	213.0	297.3	497.9	788.3	1161.7	
	SAE 8 STEEL	10,545 kg/cm ²	MEDIUM CARBON ALLOY									19.4	40.1	65.0	107.9	164.6	233.7	318.1	525.5	829.8	1220.0	
	SAE 8 STEEL	10,545 kg/cm ²	MEDIUM CARBON ALLOY									19.4	40.1	65.0	107.9	164.6	233.7	318.1	525.5	829.8	1220.0	
	SOCKET SET SCREW	14,904 kg/cm ²	HIGH CARBON QUENCHED TEMPERED					1.0	1.8	3.4	8.1	16.1	24.9	40.1	59.5	87.1	138.3	201.9				
	STUDS			Use SAE 2, 5 and 8 values when grade is known, with nut of sufficient strength.																		

foot-pounds (ft-lbs) x 1.356 = Newton-meters (Nm) inch-pounds (in-lbs) x 0.113 = Newton-meters (Nm)

SUBJECT	PAGE NO.
1.1 General	1-1
1.2 Fluid Requirements	1-7
1.3 Body Panel Care/Maintenance	1-8
1.4 Battery	1-9
1.5 Engine Lubrication System	1-10
1.6 Brake System Maintenance	1-12
1.7 Brakes Pads and Rotors	1-14
1.8 Tires and Wheels	1-15
1.9 Clutch	1-16
1.10 Transmission/Primary Fluid	1-17
1.11 Drive Belt and Rear Sprocket	1-19
1.12 Primary Chain	1-22
1.13 Rear Shock Absorber	1-23
1.14 Front Fork Oil	1-24
1.15 Steering Head Bearings	1-26
1.16 Spark Plug	1-28
1.17 Air Cleaner	1-29
1.18 Throttle Cables	1-31
1.19 Ignition Timing and Idle Speed Adjustment	1-32
1.20 Fuel Supply Valve and Filter Strainer	1-34
1.21 Starter Interlock and Electrical Switches	1-36
1.22 Critical Fastener Torque Values	1-37
1.23 Storage	1-38
1.24 Troubleshooting	1-39

SERVICING A NEW MOTORCYCLE

⚠ WARNING

Always follow the listed service and maintenance recommendations, because they affect the safe operation of the motorcycle and the personal welfare of the rider. Failure to follow recommendations could result in death or serious injury.

Service operations to be performed before customer delivery are specified in the applicable model year PREDELIVERY AND SETUP MANUAL.

The performance of new motorcycle initial service is required to keep warranty in force and to ensure proper emissions systems operation.

After a new motorcycle has been driven its first 1000 miles (1600 km) and every service interval thereafter, have a Buell dealer perform the service operations listed in [Table 1-1](#).

SAFE OPERATING MAINTENANCE

CAUTION

- **Do not attempt to retighten engine head bolts. Retightening can cause engine damage.**
- **During the initial 500 mile (800 km) break-in period, use only Harley-Davidson 20W50 engine oil. Failure to use the recommended oil will result in improper break-in of the engine cylinders and piston rings.**

A careful check of certain equipment is necessary after periods of storage, and frequently between regular service intervals, to determine if additional maintenance is required.

Check:

1. Tires for abrasions, cuts and correct pressure.
2. Drive belt for proper tension and condition.
3. Brakes, steering and throttle for responsiveness.
4. Brake fluid level and condition. Hydraulic lines and fittings for leaks. Also, check brake pads and rotors for wear.
5. Cables for fraying, crimping and free operation.
6. Engine oil and transmission fluid levels.
7. Headlamp, passing lamp, tail lamp, brake lamp and turn signal operation.

SHOP PRACTICES

Repair Notes

NOTE

- *General maintenance practices are given in this section.*
- *Repair = Disassembly/Assembly.*
- *Replace = Removal/Installation.*

All special tools and torque values are noted at the point of use.

All required parts or materials can be found in the appropriate PARTS CATALOG.

Safety

Safety is always the most important consideration when performing any job. Be sure you have a complete understanding of the task to be performed. Use common sense. Use the proper tools. Protect yourself and bystanders with approved eye protection¹⁴

. Don't just do the job – do the job safely.

Removing Parts

Always consider the weight of a part when lifting. Use a hoist whenever necessary. Do not lift heavy parts by hand. A hoist and adjustable lifting beam or sling are needed to remove some parts. The lengths of chains or cables from the hoist to the part should be equal and parallel and should be positioned directly over the center of the part. Be sure that no obstructions will interfere with the lifting operation. Never leave a part suspended in mid-air. Always use blocking or proper stands to support the part that has been hoisted.

If a part cannot be withdrawn, verify that all fastening hardware has been detached. Check to see if any parts are in the way of the part being removed.

When removing hoses, wiring or tubes, always tag each part to ensure proper installation.

Cleaning

If you intend to reuse parts, follow good shop practice and thoroughly clean the parts before reassembly. Keep all dirt out of parts. Seals, filters and covers are used in this vehicle to keep out environmental dirt and dust. These items must be kept in good condition to ensure satisfactory operation.

Clean and inspect all parts as they are removed. Be sure all holes and passages are clean and open. After cleaning, cover all parts with clean lint-free cloth, paper or other material. Be sure the part is clean when it is installed.

Always clean around lines or covers before they are removed. Plug, tape or cap holes and openings to keep out dirt, dust and debris.

Disassembly and Assembly

Always assemble or disassemble one part at a time. Do not work on two assemblies simultaneously. Be sure to make all necessary adjustments. Recheck your work when finished. Be sure that everything is done.

Operate the vehicle to perform any final check or adjustments. If all is correct, the vehicle is ready to go back to the customer.

Checking Torques on Fasteners with Lock Patches/Loctite Threadlocker

To check the torque on a fastener that has a lock patch do the following:

1. Set the torque wrench for the lowest setting in the given torque range for the fastener.
2. Attempt to tighten fastener to set torque. If fastener does not move and lowest setting is satisfied (torque wrench clicks), then the proper torque has been maintained by the fastener.
3. If the fastener does move, remove the fastener, reapply the appropriate type of LOCTITE THREADLOCKER and tighten the fastener to Service Manual specification.

REPAIR AND REPLACEMENT PROCEDURES

Hardware and Threaded Parts

Install helical thread inserts when inside threads in castings are stripped, damaged or not capable of withstanding specified torque.

Replace bolts, nuts, studs, washers, spacers and small common hardware if missing or in any way damaged. Clean up or repair minor thread damage with a suitable tap or die.

Replace all damaged or missing lubrication fittings.

Use Teflon pipe sealant on pipe fitting threads.

Wiring, Hoses and Lines

Replace hoses, clamps, electrical wiring, electrical switches or fuel lines if they do not meet specifications.

Instruments and Gauges

Replace broken or defective instruments and gauges. Replace dials and glass that are so scratched or discolored that reading is difficult.

Bearings

Anti-friction bearings must be handled in a special way. To keep out dirt and abrasives, cover the bearings as soon as they are removed from the package.

Wash bearings in a non-flammable cleaning solution. Knock out packed lubricant by tapping the bearing against a wooden block. Wash bearings again. Cover bearings with clean material after setting them down to dry. Never use compressed air to dry bearings.

Coat bearings with clean oil. Wrap bearings in clean paper.

Be sure that the chamfered side of the bearing always faces the shoulder (when bearings installed against shoulders). Lubricate bearings and all metal contact surfaces before pressing into place. Apply pressure only on the part of the bearing that makes direct contact with the mating part.

Always use the proper tools and fixtures for removing and installing bearings.

Bearings do not usually need to be removed. Remove bearings only if necessary.

Bushings

Do not remove a bushing unless damaged, excessively worn or loose in its bore. Press out bushings that must be replaced.

When pressing or driving bushings, be sure to apply pressure in line with the bushing bore. Use a bearing/bushing driver or a bar with a smooth, flat end. Never use a hammer to drive bushings.

Inspect the bushing and the mated part for oil holes. Be sure all oil holes are properly aligned.

Gaskets

Always discard gaskets after removal. Replace with **new** gaskets. Never use the same gasket twice. Be sure that gasket holes match up with holes in the mating part.

Lip Type Seals

Lip seals are used to seal oil or grease and are usually installed with the sealing lip facing the contained lubricant. Seal orientation, however, may vary under different applications.

Seals should not be removed unless necessary. Only remove seals if it is necessary to gain access to other parts or if seal damage or wear dictates replacement.

Leaking oil or grease usually means that a seal is damaged. Replace leaking seals to prevent overheated bearings.

Always discard seals after removal and replace with **new** seals. Do not use the same seal twice.

O-Rings (Preformed Packings)

Always discard O-rings after removal. Replace with **new** O-rings. To prevent leaks, lubricate the O-rings before installation. Apply the same type of lubricant as that being sealed. Be sure that all gasket, O-ring and seal mating surfaces are thoroughly clean before installation.

Gears

Always check gears for damaged or worn teeth.

Lubricate mating surfaces before pressing gears on shafts.

Shafts

If a shaft does not come out easily, check that all nuts, bolts or retaining rings have been removed. Check to see if other parts are in the way before using force.

Shafts fitted to tapered splines should be very tight. If shafts are not tight, disassemble and inspect tapered splines. Discard parts that are worn. Be sure tapered splines are clean, dry and free of burrs before putting them in place. Press mating parts together tightly.

Clean all rust from the machined surfaces of new parts.

Part Replacement

Always replace worn or damaged parts with **new** parts.

CLEANING

Part Protection

Before cleaning, protect rubber parts (such as hoses, boots and electrical insulation) from cleaning solutions. Use a grease-proof barrier material. Remove the rubber part if it cannot be properly protected.

Cleaning Process

Any cleaning method may be used as long as it does not result in parts damage. Thorough cleaning is necessary for proper parts inspection. Strip rusted paint areas to bare metal before repainting.

Rust or Corrosion Removal

Remove rust and corrosion with a wire brush, abrasive cloth, sand blasting, vapor blasting or rust remover. Use buffing crocus cloth on highly polished parts that are rusted.

Bearings

Remove shields and seals from bearings before cleaning. Clean bearings with permanent shields and seals in solution.

Clean open bearings by soaking them in a petroleum cleaning solution. Never use a solution that contains chlorine.

Let bearings air dry. Do not dry using compressed air. Do not spin bearings while they are drying.

INSPECTING

Leak Dye

When using leak dye with the black light leak detector, add 1/4 oz. (7.4 ml) of dye for each 1 quart (0.9 l) of fluid in the system being checked.

TOOL SAFETY

Air Tools

- Always use approved eye protection equipment when performing any task using air-operated tools.
- On all power tools, use only recommended accessories with proper capacity ratings.
- Do not exceed air pressure ratings of any power tools.
- Bits should be placed against work surface before air hammers are operated.
- Disconnect the air supply line to an air hammer before attaching a bit.
- Never point an air tool at yourself or another person.
- Protect bystanders with approved eye protection.

Wrenches

- Never use an extension on a wrench handle.
- If possible, always pull on a wrench handle and adjust your stance to prevent a fall if something lets go.
- Never cock a wrench.
- Never use a hammer on any wrench other than a STRIKING FACE wrench.
- Discard any wrench with broken or battered points.
- Never use a pipe wrench to bend, raise or lift a pipe.

Pliers/cutters/prybars

- Plastic- or vinyl-covered pliers handles are not intended to act as insulation; do not use on live electrical circuits.
- Do not use pliers or cutters for cutting hardened wire unless they were designed for that purpose.
- Always cut at right angles.
- Do not use any prybar as a chisel, punch or hammer.

Hammers

- Never strike one hammer against a hardened object, such as another hammer.
- Always grasp a hammer handle firmly, close to the end.
- Strike the object with the full face of the hammer.
- Never work with a hammer which has a loose head.
- Discard hammer if face is chipped or mushroomed.
- Wear approved eye protection when using striking tools.
- Protect bystanders with approved eye protection.

Punches/chisels

- Never use a punch or chisel with a chipped or mushroomed end; dress mushroomed chisels and punches with a file.
- Hold a chisel or a punch with a tool holder if possible.
- When using a chisel on a small piece, clamp the piece firmly in a vise and chip toward the stationary jaw.
- Wear approved eye protection when using these tools.
- Protect bystanders with approved eye protection.

Screwdrivers

- Don't use a screwdriver for prying, punching, chiseling, scoring or scraping.
- Use the right type of screwdriver for the job; match the tip to the fastener.
- Don't interchange POZIDRIV®, PHILLIPS® or REED AND PRINCE screwdrivers.
- Screwdriver handles are not intended to act as insulation; do not use on live electrical circuits.
- Don't use a screwdriver with rounded edges because it will slip – redress with a file.

Ratchets and Handles

- Periodically clean and lubricate ratchet mechanisms with a light grade oil. Do not replace parts individually; ratchets should be rebuilt with the entire contents of service kit.

- Never hammer or put a pipe extension on a ratchet or handle for added leverage.
- Always support the ratchet head when using socket extensions, but do not put your hand on the head or you may interfere with the action of its reversing mechanism.
- When breaking loose a fastener, apply a small amount of pressure as a test to be sure the ratchet's gear wheel is engaged with the pawl.

Sockets

- Never use hand sockets on power or impact wrenches.
- Select the right size socket for the job.
- Never cock any wrench or socket.
- Select only impact sockets for use with air or electric impact wrenches.
- Replace sockets showing cracks or wear.
- Keep sockets clean.
- Always use approved eye protection when using power or impact sockets.

Storage Units

- Don't open more than one loaded drawer at a time. Close each drawer before opening up another.
- Close lids and lock drawers and doors before moving storage units.
- Don't pull on a tool cabinet; push it in front of you.
- Set the brakes on the locking casters after the cabinet has been rolled to your work.

Table 1-1. REGULAR MAINTENANCE INTERVALS

ODOMETER READING SERVICE OPERATIONS (see chart code below)	1	2	5	7	1	1	1	1	2	2	2
	0	5	0	5	0	5	0	5	0	5	0
	0	0	0	0	0	0	0	0	0	0	0
	0	0	0	0	0	0	0	0	0	0	0
	mi	mi	mi	mi	mi	mi	mi	mi	mi	mi	mi
Change engine oil and filter (includes draining crankcase breather hose)	R	I	R	I	R	I	R	I	R	I	R
Inspect air cleaner and filter element, service as required					I				I		
Change rear belt and rear sprocket							R				
Check clutch adjustment	I		I		I		I		I		I
Change transmission/primary chain case lubricant and clean drain plug—See dealer	R		R		R		R		R		R
Check/adjust primary chain	A	A	A	A	A	A	A	A	A	A	A
Inspect brake pad linings and discs for wear (front and rear)	I	I	I	I	I	I	I	I	I	I	I
Change rear brake pads and rear brake pins							R				
Check brake fluid reservoir levels and condition	I		I		I		I		I		I
Check rear brake pedal operation	I		I		I		I		I		I
Inspect oil lines and brake system for leaks	I	I	I	I	I	I	I	I	I	I	I
Lubricate front brake hand lever, throttle control cables, clutch control cables (and hand lever) and side stand			L		L		L		L		L
Lubricate and adjust steering head bearings									X		
Check operation and throttle control	I	I	I	I	I	I	I	I	I	I	I
Inspect fuel valve, lines and fittings for leaks	I	I	I	I	I	I	I	I	I	I	I
Clean fuel tank filter screen									X		
Check operation of all electrical equipment & switches including starter interlock	I	I	I	I	I	I	I	I	I	I	I
Check battery and clean connections	I	I	I	I	I	I	I	I	I	I	I
Change spark plug					R				R		
Check tire pressure and inspect tread	I	I	I	I	I	I	I	I	I	I	I
Check wheel bearings*											
Change front fork oil									X		
Check stabilizer links and engine mounts					I				I		
Check tightness of all critical fasteners: hand controls, brake system, axle nuts, front fork components, riser and handle bar fasteners.					T				T		
Check rear shock absorber					I				I		
Check ignition timing					I				I		
Check engine idle speed	I	I	I	I	I	I	I	I	I	I	I
Inspect exhaust system hardware; including muffler strap					I				I		
Road test	X	X	X	X	X	X	X	X	X	X	X

* Whenever wheel is removed (tire change, fork fluid change, etc.)

NOTE:

See **Table 1-1. The following codes are for the REGULAR MAINTENANCE INTERVALS Table:**

- I - Inspect & if necessary correct, clean or replace.
- A - Adjust.
- R - Replace or change.
- T - Tighten to proper torque
- L - Lubricated with specified lubricant
- X - Perform

Table 1-2. REGULAR MAINTENANCE INTERVALS

ODOMETER READING SERVICE OPERATIONS (see chart code below)	1	2	5	7	1	1	1	1	2	2	2
	0	5	0	5	0	5	0	5	0	5	0
	0	0	0	0	0	0	0	0	0	0	0
	0	0	0	0	0	0	0	0	0	0	0
	mi	mi	mi	mi	mi	mi	mi	mi	mi	mi	mi
Change engine oil and filter (includes draining crankcase breather hose)	R	I	R	I	R	I	R	I	R	I	R
Inspect air cleaner and filter element, service as required					I				I		
Change rear belt and rear sprocket							R				
Check clutch adjustment	I		I		I		I		I		I
Change transmission/primary chain case lubricant and clean drain plug—See dealer	R		R		R		R		R		R
Check/adjust primary chain	A	A	A	A	A	A	A	A	A	A	A
Inspect brake pad linings and discs for wear (front and rear)	I	I	I	I	I	I	I	I	I	I	I
Change rear brake pads and rear brake pins							R				
Check brake fluid reservoir levels and condition	I		I		I		I		I		I
Check rear brake pedal operation	I		I		I		I		I		I
Inspect oil lines and brake system for leaks	I	I	I	I	I	I	I	I	I	I	I
Lubricate front brake hand lever, throttle control cables, clutch control cables (and hand lever) and side stand			L		L		L		L		L
Lubricate and adjust steering head bearings									X		
Check operation and throttle control	I	I	I	I	I	I	I	I	I	I	I
Inspect fuel valve, lines and fittings for leaks	I	I	I	I	I	I	I	I	I	I	I
Clean fuel tank filter screen									X		
Check operation of all electrical equipment & switches including starter interlock	I	I	I	I	I	I	I	I	I	I	I
Check battery and clean connections	I	I	I	I	I	I	I	I	I	I	I
Change spark plug					R				R		
Check tire pressure and inspect tread	I	I	I	I	I	I	I	I	I	I	I
Check wheel bearings*											
Change front fork oil									X		
Check stabilizer links and engine mounts					I				I		
Check tightness of all critical fasteners: hand controls, brake system, axle nuts, front fork components, riser and handle bar fasteners.					T				T		
Check rear shock absorber					I				I		
Check ignition timing					I				I		
Check engine idle speed	I	I	I	I	I	I	I	I	I	I	I
Inspect exhaust system hardware; including muffler strap					I				I		
Road test	X	X	X	X	X	X	X	X	X	X	X

* Whenever wheel is removed (tire change, fork fluid change, etc.)

NOTE:

See Table 1-1. The following codes are for the REGULAR MAINTENANCE INTERVALS Table:

I - Inspect & if necessary correct, clean or replace.

A - Adjust.

R - Replace or change.

T - Tighten to proper torque

L - Lubricated with specified lubricant

X - Perform

GENERAL

United States System

Unless otherwise specified, **all fluid volume measurements in this Service Manual are expressed in United States (U.S.) units-of-measure.** See below:

- Pint (U.S.) = 16 fluid ounces (U.S.)
- Quart (U.S.) = 2 pints (U.S.) = 32 fl. oz. (U.S.)
- Gallon (U.S.) = 4 quarts (U.S.) = 128 fl. oz. (U.S.)

British Imperial System

Fluid volume measurements in this Service Manual do not include the British Imperial (Imp.) system equivalents. The following conversions exist in the British Imperial system:

- Pint (Imp.) = 20 fluid ounces (Imp.)
- Quart (Imp.) = 2 pints (Imp.)
- Gallon (Imp.) = 4 quarts (Imp.)

Although the same unit-of-measure terminology as the U.S. system is used in the British Imperial (Imp.) system, the actual volume of each British Imperial unit-of-measure differs from its U.S. counterpart. The U.S. fluid ounce is larger than the British Imperial fluid ounce. However, the U.S. pint, quart and gallon are smaller than the British Imperial pint, quart and gallon, respectively. Should you need to convert from U.S. units to British Imperial units (or vice versa), refer to the following:

- Fluid ounces (U.S.) x 1.042 = fluid ounces (Imp.)
- Pints (U.S.) x 0.833 = pints (Imp.)
- Quarts (U.S.) x 0.833 = quarts (Imp.)
- Gallons (U.S.) x 0.833 = gallons (Imp.)
- Fluid ounces (Imp.) x 0.960 = fluid ounces (U.S.)
- Pints (Imp.) x 1.201 = pints (U.S.)
- Quarts (Imp.) x 1.201 = quarts (U.S.)
- Gallons (Imp.) x 1.201 = gallons (U.S.)

Metric System

Fluid volume measurements in this Service Manual include the metric system equivalents. In the metric system, 1 liter (L) = 1,000 milliliters (mL). Should you need to convert from U.S. units-of-measure to metric units-of-measure (or vice versa), refer to the following:

- Fluid ounces (U.S.) x 29.574 = milliliters
- Pints (U.S.) x 0.473 = liters
- Quarts (U.S.) x 0.946 = liters
- Gallons (U.S.) x 3.785 = liters
- Milliliters x 0.0338 = fluid ounces (U.S.)
- Liters x 2.114 = pints (U.S.)
- Liters x 1.057 = quarts (U.S.)
- Liters x 0.264 = gallons (U.S.)

BRAKE FLUID

⚠ WARNING

D.O.T. 4 brake fluid can cause irritation of eyes and skin, and may be harmful if swallowed. If large amount of fluid is swallowed, induce vomiting by administering two tablespoons of salt in a glass of warm water. Call a doctor. In case of contact with skin or eyes, flush with plenty of water. Get medical attention for eyes. KEEP BRAKE FLUID OUT OF THE REACH OF CHILDREN. Failure to comply could result in death or serious injury.

Use only **D.O.T. 4 BRAKE FLUID** (Part No. 99953-99Y).

FRONT FORK OIL

Use only **TYPE E FORK OIL** (Part No. HD-99884-80).

ENGINE OIL

Use the proper grade of oil for the lowest temperature expected before the next oil change.

If it is necessary to add oil and Harley-Davidson oil is not available, use an oil certified for diesel engines. Acceptable diesel engine oil designations include CE, CF, CF-4 and CG-4. The preferred viscosities for the diesel engine oils, in descending order, are 20W-50, 15W-40 and 10W-40. At the first opportunity, see a Buell dealer to change back to 100 percent Harley-Davidson oil.

Table 1-2. Recommended Oil Grades

HARLEY-DAVIDSON TYPE	VISCOSITY	HARLEY-DAVIDSON RATING	LOWEST AMBIENT TEMP.	COLD WEATHER STARTS BELOW 50° F
H.D. Multi-Grade	SAE 10W40	HD 360	Below 40° F (4°C)	Excellent
H.D. Multi-Grade	SAE 20W50	HD 360	Above 40° F (4°C)	Good
H.D. Regular Heavy	SAE 50	HD 360	Above 60° F (16°C)	Poor
H.D. Extra Heavy	SAE 60	HD 360	Above 80° F (27°C)	Poor

PRIMARY DRIVE/TRANSMISSION FLUID

Use only **SPORT-TRANS FLUID** (Part No. 98854-96 quart size or Part No. 98855-96 gallon size).

GENERAL

The purpose of this topic is to provide special care and maintenance instructions required for the molded-in-color body panels that are standard on your Buell Blast P3 motorcycle.

Molded-in-color surfaces look like painted surfaces, but are not. The color pigment is mixed in with the material when the part is made, not applied over the surface. Molded-in-color panels require different maintenance than painted surfaces to maintain their original shine. Using methods that work on painted surfaces may ruin the finish of molded-in-color parts.

CAUTION

Use of abrasive products or powered buffing equipment will cause permanent cosmetic damage to molded-in-color body panels. Use only the recommended products and techniques outlined in these instructions to avoid damaging molded-in-color body panels.

CAUTION

Do not use touch-up paint on molded-in-color panels.

RECOMMENDED PRODUCTS

Products recommended for the proper care and maintenance of molded-in-color body panels are available at your Buell dealer and are listed below:

- Harley Wash (Part No. 99715-90) or Harley Sun Wash (Part No. 94659-98).
- Harley Gloss (Part No. 94627-98).
- Harley Glaze Polish and Sealant (Part No. 99701-84).
- Harley Swirl and Scratch Treatment (Part No. 94655-98)
- Harley Softcloth (Part No. 94656-98)

CARE AND MAINTENANCE

Decals

NOTE

The body panels on Blast P3 Models are shipped from the factory untreated and ready for decal application.

If Personal F/X decals are to be applied to molded-in-color body panels, they must be applied to the original, untreated surface for proper adhesion. If Harley Glaze Polish and Sealant or similar product has been applied to the panels, the decal will not adhere properly. Apply wax and grease remover, such as Dupont Prep-Sol, to treated panels to remove Harley Glaze prior to applying decals for best results. Prep-Sol is available at most automotive aftermarket dealers. Follow instructions on product for proper usage. Follow instructions provided with decals for proper application. Prep-Sol will not affect molded-in-color panels. If you are unsure of how to use this product, see your Buell dealer.

Washing

To wash molded-in-color panels follow the instructions below:

Rinse surface with water.

Wash with Harley Wash or Harley Sun Wash.

Rinse surface thoroughly with water.

Dry with a clean chamois or soft dry natural fiber cloth.

Cleaning Between Washings

Untreated molded-in-color body panels sometimes have a static charge that attracts dust. Applying Harley Gloss or Harley Glaze Polish and Sealant to molded-in-color surfaces will eliminate this condition.

To keep a high gloss finish on molded-in-color panels between washings, follow the instructions below:

Spray Harley Gloss onto surface and wipe with a clean soft natural fiber cloth or Harley Softcloth.

NOTE

Rain or water will remove Harley Gloss from body panels.

Reapply Harley Gloss as described above to keep surfaces looking their best.

Polishing

Polishing molded-in-color body panels results in greater surface gloss and a protective coating.

Apply Harley Glaze Polish and Sealant every six months or as required to keep molded-in-color panels protected and looking their best.

Clean and dry surfaces to be polished (see *Washing*).

Apply Harley Glaze Polish and Sealant to clean, slightly dampened cloth or sponge and apply to surface with a light overlapping motion. Make sure to cover all areas.

Let Harley Glaze Polish and Sealant dry to a haze and buff off residue with a clean soft cloth or Harley Softcloth.

Minor Scratch Removal

To remove minor scratches from body panels follow the instructions below.

To remove light surface scratches and rubs, use Harley Swirl and Scratch Treatment as recommended.

Make sure Swirl and Scratch Treatment is applied with a moist cloth and by hand (not by machine).

After scratch or rub has been repaired, polish surface lightly with Harley Glaze.

NOTE

Black body panels are more prone to suffer permanent cosmetic damage if attempts to remove scratches are overdone.

Major Scratches

There is no repair procedure for severely scratched surfaces. Severely scratched body panels must be replaced.

DISCONNECTION AND REMOVAL

1. Remove seat. See [2.29 SEAT](#).

WARNING

To protect against shock and accidental start-up of vehicle, disconnect the negative battery cable before proceeding. Inadequate safety precautions could result in death or serious injury.

WARNING

Always disconnect the negative cable first. If the positive cable should contact ground with the negative cable installed, the resulting sparks may cause a battery explosion which could result in death or serious injury.

2. Unthread bolt and remove battery negative cable (black) from battery negative (-) terminal.
3. Unthread bolt and remove battery positive cable (red) from battery positive (+) terminal.
4. Remove battery from motorcycle.

INSTALLATION AND CONNECTION

1. Place the fully charged battery on the battery pad, terminal side facing up.

CAUTION

Connect the cables to the correct battery terminals or damage to the motorcycle electrical system will occur.

WARNING

Always connect the positive battery cable first. If the positive cable should contact ground with the negative cable installed, the resulting sparks may cause a battery explosion which could result in death or serious injury.

CAUTION

Overtightening bolts can damage battery terminals.

2. See Figure 1-1. Insert bolt through battery positive cable (red) into threaded hole of battery positive (+) terminal. Tighten bolt to 60-96 **in-lbs** (6.8-10.9 Nm).
3. See Figure 1-1. Insert bolt through battery negative cable (black) into threaded hole of battery negative (-) terminal. Tighten bolt to 60-96 **in-lbs** (6.8-10.9 Nm).
4. Apply a light coat of petroleum jelly or corrosion retardant material to both battery terminals.
5. Install seat. See [2.29 SEAT](#).

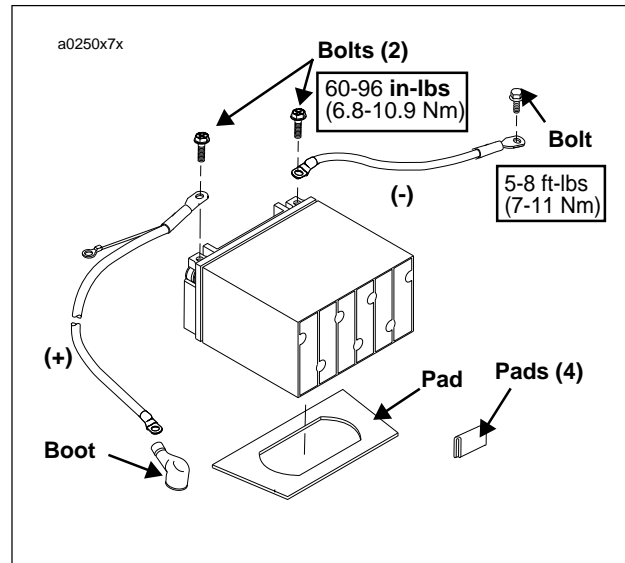

Figure 1-1. Battery Installation

GENERAL

Check engine oil level (hot check):

- At every stop for fuel.

Inspect oil lines and filter for leaks:

- At 1,000 mi (1,600 km) initial service and every 2,500 mi (4,000 km) service interval.

Change engine oil and filter (and drain crankcase breather hose) under normal service in warm or moderate temperatures:

- At 1,000 mi (1,600 km) initial service and every 5,000 mi (8,000 km) service interval thereafter.

Change engine oil and filter (and drain crankcase breather hose) under severe service in warm or moderate temperatures (severe dust, temperatures above 80°F/27°C, extensive idling or speeds in excess of 65 mph/105 km/h, extensive two-up riding):

- At 1,000 mi (1,600 km) initial service and every 2,500 mi (4,000 km) service interval thereafter.

NOTE

Shorten oil change interval in cold weather.

CHECKING ENGINE OIL LEVEL

An accurate engine oil level reading can *only* be obtained with the engine is at normal operating temperature (Hot Check). The engine will require a longer warm up period in colder weather.

For pre-ride inspection, simply verify that there are no oil leaks from the oil filter and oil lines prior to operating the motorcycle.

- Perform a hot check of the engine oil level at each fuel stop.

Hot Check

CAUTION

Do not allow hot oil level to fall below lower mark on dipstick. To do so may result in equipment damage and/or equipment malfunction.

CAUTION

Do not overfill oil tank. Doing so may result in oil carry-over to the air cleaner, equipment damage and/or equipment malfunction.

CAUTION

Do not switch engine oil brands indiscriminately. Some oils interact chemically when mixed. Use of inferior oils or non-detergent oils can damage the engine.

The motorcycle should be ridden for approximately 10 minutes to ensure oil is hot and engine is at normal operating temperature.

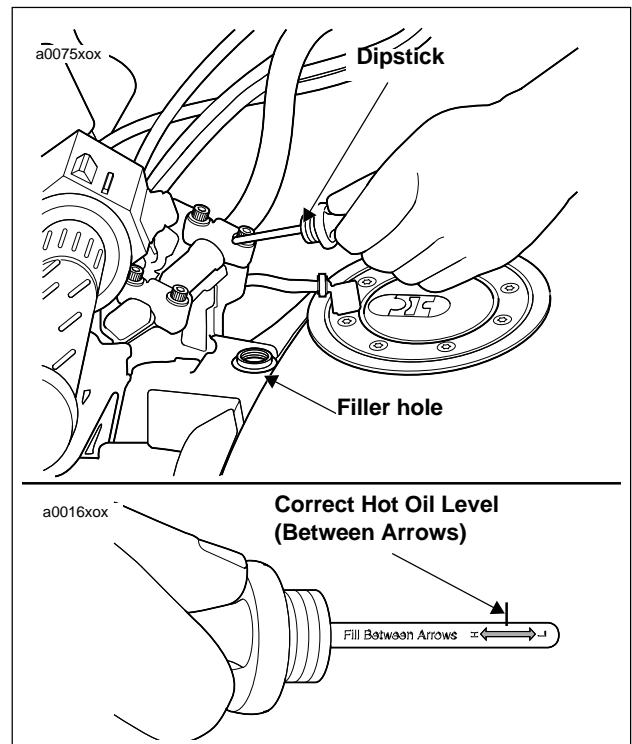

Figure 1-2. Dipstick Location/Engine Oil Level

1. The motorcycle must be in upright position and level (not on sidestand) with the engine OFF.
2. See Figure 1-2. Unscrew dipstick from frame filler hole.
3. Wipe off dipstick and insert into frame filler hole, screwing dipstick completely into filler neck.
4. See Figure 1-2. Remove dipstick and note oil level.
5. Hot oil level should be between the upper and lower “fill” marks on dipstick. If oil level is down to or below lower “fill” mark on dipstick, add only enough oil to bring level between lower and upper “fill” marks.

Table 1-3. Recommended Engine Oils

Harley-Davidson Type	Viscosity	Harley-Davidson Rating	Lowest Ambient Temperature	Cold Weather Starts Below 50°F (10°C)
HD Multi-grade	SAE 10W40	HD 360	Below 40°F (4°C)	Excellent
HD Multi-grade	SAE 20W50	HD 360	Above 40°F (4°C)	Good
HD Regular Heavy	SAE 50	HD 360	Above 60°F (16°C)	Poor
HD Extra Heavy	SAE 60	HD 360	Above 80°F (27°C)	Poor

CHANGING ENGINE OIL AND FILTER

CAUTION

Do not switch oil brands indiscriminately; some oils interact chemically when mixed. Use of inferior oils or non-detergent oils can damage the engine.

1. See Figure 1-3. Locate the engine oil tank drain hose (normally the lower hose) and the crankcase breather drain hose (normally the upper hose) inside the foot peg support frame on the left side of the motorcycle.
2. Remove fastener from hose retention clamp.
3. Place a drain pan directly underneath the engine oil drain hose.
4. Loosen the spring clamp and remove engine oil drain plug from drain hose.
5. Allow used oil to drain completely.
6. Loosen spring clamp and remove crankcase breather hose drain plug to allow any oil present to drain.
7. See Figure 1-4. Remove the oil filter (located at the front of the engine).
8. Clean filter gasket contact surface on mounting plate (surface should be smooth and free of any debris, used oil or old gasket material).
9. See Figure 1-4. Apply a thin film of clean oil to gasket on new oil filter.
10. Install **new** oil filter (Part No. 63806-00Y) onto adapter until gasket contacts plate surface, then tighten another 1/2 to 3/4 turn. Do not overtighten.
11. Place two drain hoses back on the hose fixture. Install drain plugs to drain hoses and secure plugs with spring clamps.
12. See Figure 1-2. See Table 1-3. Remove dipstick and refill with approximately 1.5 qts (1,419.5 ml) recommended oil at filler hole.
13. Install dipstick and operate motorcycle for 10 minutes to reach normal operating temperature. Check oil level again (hot check) and add oil as necessary until oil registers between marks on dipstick.

WARNING

Make sure no oil gets on tires when changing oil and filter. Failure to comply may adversely affect traction which could lead to a loss of control which could result in death or serious injury.

- Change oil more frequently if bike is operated under severe conditions (dusty, very hot or cold temperatures).
- Drain oil after operating motorcycle (while oil is still very warm).
- Replace oil filter every time the oil is changed.
- Drain the crankcase breather drain hose of any accumulated oil every time the oil is changed.

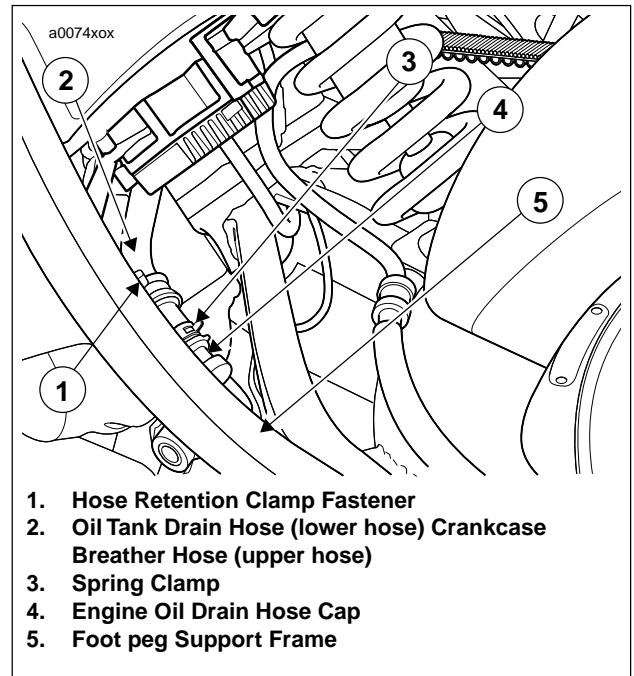

Figure 1-3. Oil Tank Drain Hose

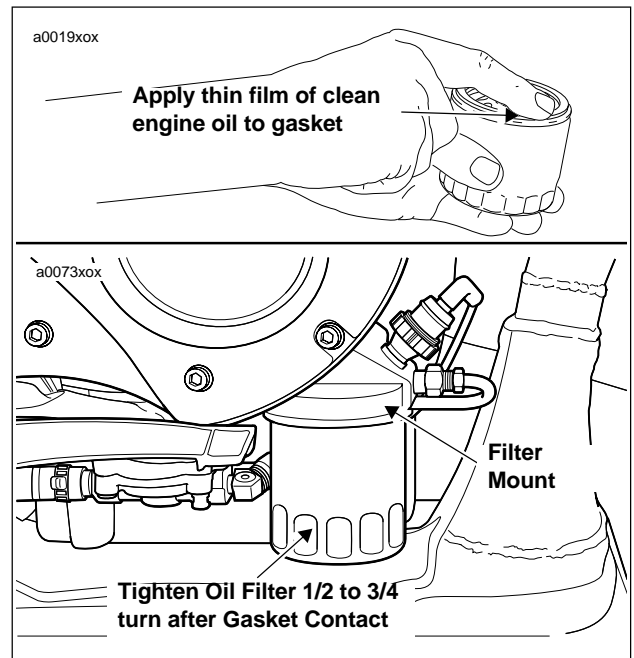

Figure 1-4. Installing New Oil Filter

GENERAL

Check the master cylinder reservoirs for proper fluid levels after the first 1000 miles (1600 km) and every 5000 miles (8000 km) thereafter. Also inspect fluid levels at the end of every riding season.

Check brake pads and rotors for wear at every service interval. See [1.7 BRAKE PADS AND ROTORS](#).

Inspect front and rear brake fluid level and condition:

- At 1,000 mile (1600 km) initial service and at every 5,000 mile (8,000 km) service thereafter.

Replace **D.O.T. 4 BRAKE FLUID**:

- Every 2 years.

Inspect front and rear brake system fitting and lines for leaks:

- At 1,000 mile (1600 km) initial service and at every service thereafter.

It is recommended to inspect both front and rear brake lines and replace as required:

- Every 4 years.

It is recommended to inspect both front and rear caliper and master cylinder seals and replace as required:

- Every 2 years.

Check rear brake pedal operation:

- Before every ride.
- At the 1000 mile (1600 km) service interval.
- At every 5000 mile (8000 km) service interval thereafter.

Lubricate the front brake hand lever:

- Every 5,000 miles (8,000 km)

FLUID LEVEL

See [Figure 1-5](#). With motorcycle in a level position, check that brake fluid is between the upper and lower marks on front and rear reservoirs. Add **D.O.T. 4 BRAKE FLUID** if necessary. Be sure gasket and cap on reservoir fit securely.

BLEEDING BRAKES

⚠ WARNING

D.O.T. 4 brake fluid can cause irritation of eyes and skin, and may be harmful if swallowed. If large amount of fluid is swallowed, induce vomiting by administering two tablespoons of salt in a glass of warm water. Call a doctor. In case of contact with skin or eyes, flush with plenty of water. Get medical attention for eyes. **KEEP BRAKE FLUID OUT OF THE REACH OF CHILDREN.** Failure to comply could result in death or serious injury.



Figure 1-5. Rear Brake Fluid Reservoir

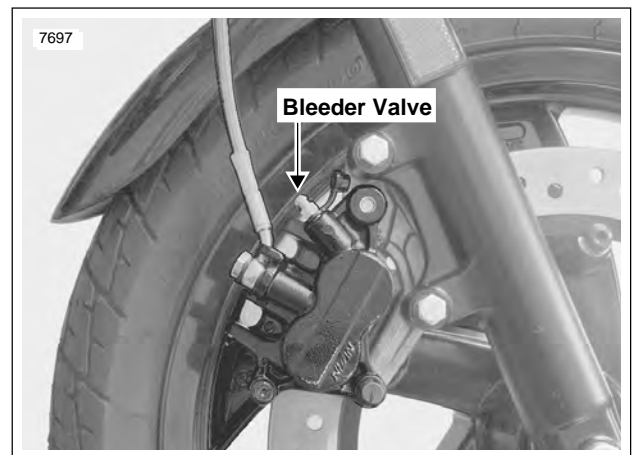

Figure 1-6. Front Brake Caliper Bleeder Valve

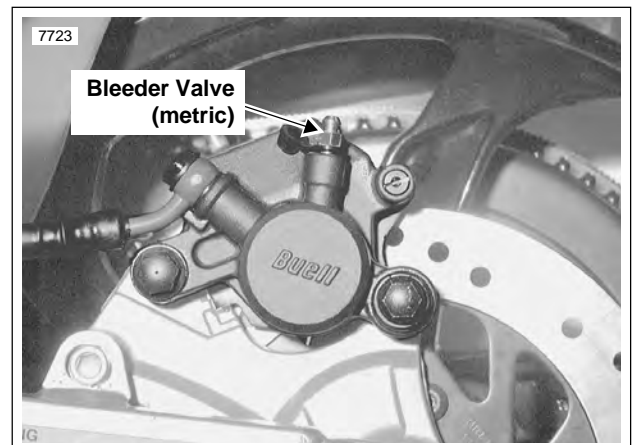

Figure 1-7. Rear Brake Caliper Bleeder Valve (Metric)

WARNING

Never mix D.O.T. 4 with other brake fluids (such as D.O.T. 5). Use only D.O.T. 4 brake fluid in motorcycles that specify D.O.T. 4 fluid on the reservoir cap. Mixing different types of fluid may adversely affect braking ability and lead to brake failure which could result in death or serious injury

WARNING

Use only fresh, uncontaminated D.O.T. 4 Fluid. Cans of fluid that have been opened may have been contaminated by moisture in the air or dirt. Use of contaminated brake fluid may adversely affect braking ability and lead to brake failure which could result in death or serious injury

WARNING

Use only new black banjo washers (See Parts Catalog for Part No.) with D.O.T. 4 brake fluid. Earlier silver banjo washers are not compatible with D.O.T. 4 fluid and will not seal properly over time. Failure to comply may adversely affect braking ability and lead to brake failure which could result in death or serious injury.

NOTE

Hydraulic brake fluid bladder-type pressure equipment can be used to fill the brake master cylinder through the bleeder valve if master cylinder reservoir cover is removed to prevent pressurization.

1. Install end of a length of plastic tubing over caliper bleeder valve; place other end in a clean container. Stand motorcycle upright.
 - a. See Figure 1-6. Front brake bleeder valve.
 - b. See Figure 1-7. Rear brake bleeder valve.

CAUTION

Cover molded-in-color surfaces and right handlebar switches and use care when removing brake reservoir cover and adding D.O.T. 4 brake fluid. Spilling D.O.T. 4 brake fluid on molded-in-color surfaces will result in cosmetic damage. Spilling brake fluid on switches may render them inoperative.

2. Add **D.O.T. 4 BRAKE FLUID** to master cylinder reservoir. Do not reuse brake fluid.
 - a. Remove two screws from front master cylinder cover. Bring fluid level to within 0.125 in. (3.2 mm) of molded boss inside front master cylinder.
 - b. Remove cap and gasket from rear master cylinder reservoir. Bring fluid level to between upper and lower marks on reservoir.
3. Depress, release and then hold brake lever/pedal to build up hydraulic pressure.
4. Open bleeder valve (metric) about 1/2-turn counterclockwise; brake fluid will flow from bleeder valve and through tubing. When brake lever/pedal has moved 1/2-3/4 of its full range of travel, close bleeder valve (clockwise). Allow brake lever/pedal to return slowly to its released position.
5. Repeat Steps 2-4 until all air bubbles are purged.
6. Tighten bleeder valve (metric) to 3-5 ft-lbs (4.1-6.8 Nm).

7. Verify master cylinder fluid level as described in Step 2.

WARNING

Always test motorcycle brakes at low speed after servicing or bleeding system. If brakes are not operating properly, or braking efficiency is poor, testing at high speeds could result in death or serious injury.

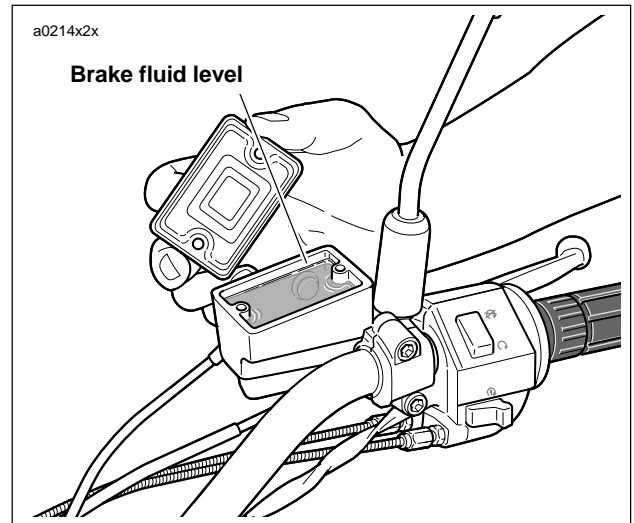

Figure 1-8. Brake Fluid Level - Front Reservoir

8. Attach covers to master cylinder reservoirs.
 - a. Tighten screws on master cylinder reservoir cover to 9-13 **in-lbs** (1.0-1.5 Nm).
 - b. Tighten cap on rear master cylinder securely.

REAR BRAKE PEDAL**WARNING**

Always test motorcycle brakes at low speed after servicing or bleeding system. If brakes are not operating properly, or braking efficiency is poor, testing at high speeds could result in death or serious injury.

Check rear brake pedal for proper operation.

- Before every ride.
 - At the 1000 mile (1600 km) service interval and at every 5000 mile (8000 km) service interval thereafter.
1. Inspect locknut installation. Locknut should be flush with top surface of clevis.
 2. Observe the position of brake pedal and foot peg. Brake pedal should be set so top surface of brake pedal is even with top surface of foot peg.
 3. Set brake pedal height.
 - a. Loosen locknut.
 - b. Turn rod adjuster to obtain correct position.
 - c. Tighten locknut.

NOTE

Brake pedal has no freerplay adjustment.

BRAKE PADS

⚠ WARNING

Always replace brake pads in complete sets for correct brake operation. Never replace just one brake pad. Failure to install brake pads as a set could result in death or serious injury.

Check front and rear brake pads for minimum thickness:

- At the 1000 mile (1600 km) service interval.
- At every scheduled service interval thereafter.

See Figure 1-9. See Figure 1-10. Inspect brake pads for damage or excessive wear. Replace both pads as a set if friction material of either pad is worn to 0.04 in. (1.0 mm) or less. If this amount of wear occurs, wear grooves (2) will disappear from friction material surface.

Replace rear brake pads and pins:

- Every 15,000 miles (24,000 km)

NOTE

Always replace brake pads in pairs.

BRAKE ROTORS

⚠ WARNING

Do not allow brake fluid, bearing grease or other lubricants to contact brake rotor or reduced braking ability may occur, which could result in death or serious injury.

Check front and rear brake rotors for minimum thickness:

- At the 1000 mile (1600 km) service interval.
 - At every scheduled service interval thereafter.
1. Measure rotor thickness. Replace if minimum thickness is less than 0.18 in. (4.5 mm).
 2. Check rotor surface. Replace if warped or badly scored.
 3. The brake rotor must be within the following specifications. If the brake rotor is suspected of being damaged, inspect rotor using the following measurements:
 - Lateral Movement: 0.01-0.02 in. (0.3-0.5 mm)
 - Radial Movement: 0.02 in. (0.45 mm)
 - Rotational Movement: 0.02 in. (0.39 mm)

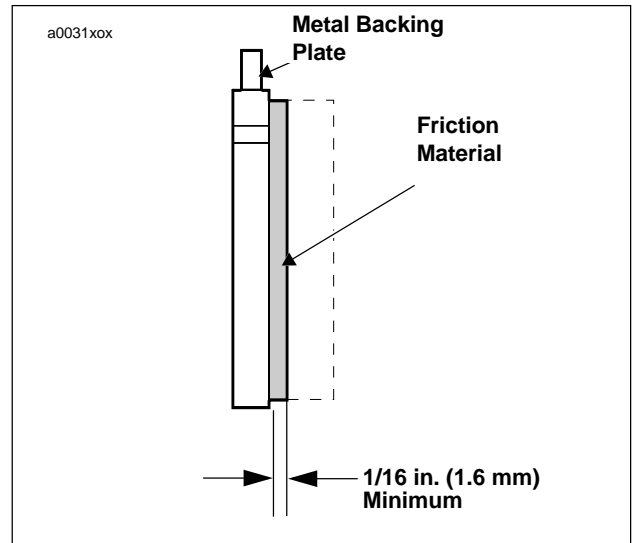

Figure 1-9. Brake Pad - Side View

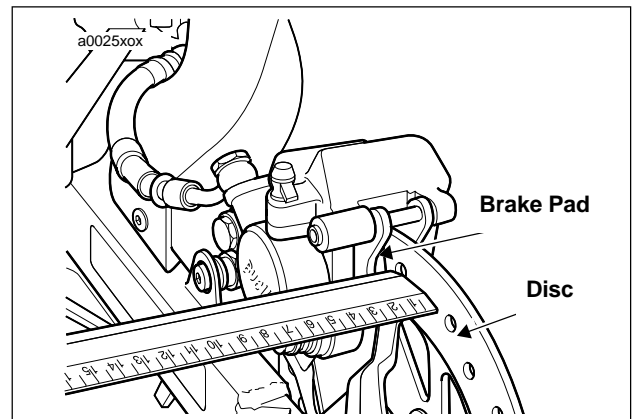

Figure 1-10. Measuring Rear Brake Outer Pad

TIRE INFLATION

Check front and rear tires for proper inflation and inspect tread for cuts or punctures:

- Weekly, and at 1,000 mile (1,600 km) initial service and at every 2,500 mile (4,000 km) service interval thereafter.

WHEEL BEARINGS

The wheel bearings are sealed units, no greasing or maintenance is required. Replace when worn. Excessive play or roughness indicates worn bearings that require replacement.

Check wheel bearings:

- Whenever wheel is removed (tire change, fork oil change).

1-4. Tire Specifications/Pressures

P3 Tires	SOLO RIDING	LOADED TO GVWR
Front Dunlop 100/80 16 50s K330	28 psi (193 kPa)	32 psi (220 kPa)
Rear Dunlop 120/80 16 60s K330	30 psi (207 kPa)	36 psi (248 kPa)

GENERAL

Check clutch for proper adjustment:

- At the 1,000 mile (1,600 km) initial service and at every 5,000 mile (8,000 km) service interval thereafter.

Oil and adjust the clutch control cable:

- Every 5,000 miles (8,000 km) with LUBIT-8 TUFOIL CHAIN AND CABLE LUBE (Part No. 94968-85TV).

ADJUSTMENT

Clutch control cable adjustment is required at this interval to compensate for normal clutch lining wear. If the clutch slips under load, or drags when released, adjust the clutch control cable.

1. Raise rear wheel off floor using REAR WHEEL SUPPORT STAND (Part No. B-41174).
2. Remove left footpeg support bracket. See 2.22 FOOTPEGS AND FOOTPEG SUPPORT BRACKETS.
3. See Figure 1-11. Slide rubber boot (1) upward to expose adjuster mechanism. Loosen jam nut (3) from adjuster (4). Turn adjuster to shorten cable housing until there is a large amount of freeplay at clutch hand lever.
4. See Figure 1-12. Remove three TORX screws with washers (1) from clutch inspection cover (2). Remove clutch inspection cover from primary cover.

NOTE

Quad ring removed from primary cover for illustrative purposes only in Figure 1-12.

5. Remove spring (4) and lockplate (5). Turn adjusting screw (6) counterclockwise until it lightly bottoms.
6. Turn adjusting screw (6) clockwise 1/4 turn. Install lockplate (5) and spring (4) on adjusting screw flats. If hex on lockplate does not align with recess in outer ramp, rotate adjusting screw clockwise until it aligns.
7. Squeeze clutch hand lever to maximum limit three times. This sets the ball and ramp mechanism. Pull outer cable conduit and at the same time adjust cable adjuster to provide 0.0625-0.125 in. (1.6-3.2 mm) freeplay at clutch hand lever. Adjust as follows.
 - a. See Figure 1-13. Pull ferrule (end of cable housing) away from bracket. Gap between ferrule and bracket should be 0.0625-0.125 in. (1.6-3.2 mm).
 - b. See Figure 1-11. Set freeplay by turning adjuster.
 - c. Tighten jam nut against adjuster.
 - d. Slide rubber boot over cable adjuster mechanism.
8. Change or add transmission fluid if necessary.

NOTE

Clean parts before re-assembly and use a new gasket.

9. See Figure 1-12. Install clutch inspection cover using three TORX screws with washers. Tighten in a crosswise pattern to 7-9 ft-lbs (9.5-12.2 Nm).
10. Check clutch cable freeplay. See Step 6 above.

11. Install left footpeg support bracket. See 2.22 FOOTPEGS AND FOOTPEG SUPPORT BRACKETS.

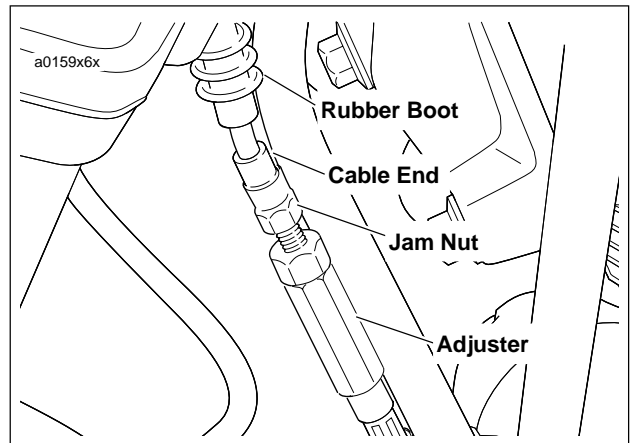

Figure 1-11. Clutch Cable Adjuster Mechanism

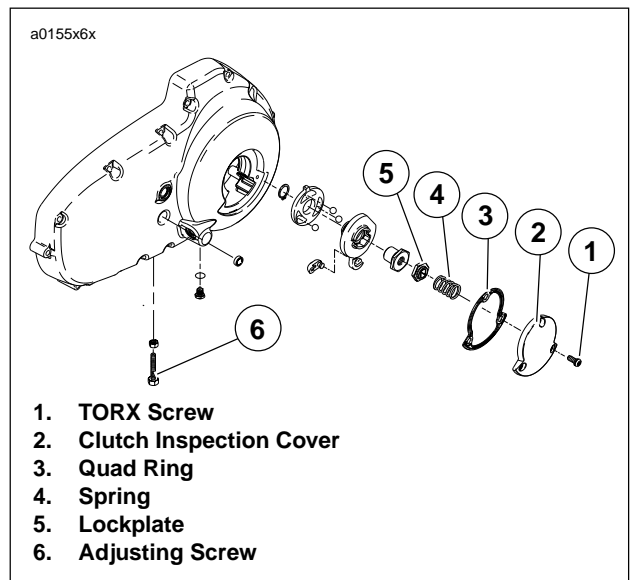

Figure 1-12. Clutch Release Mechanism

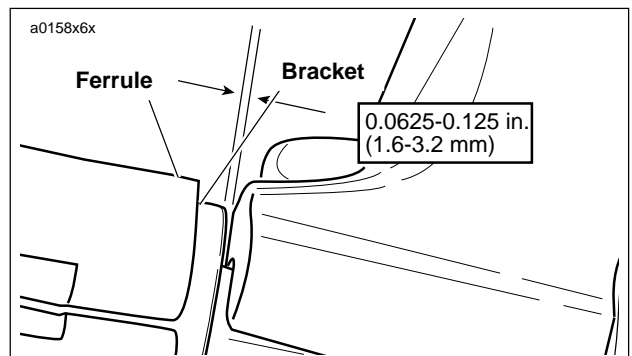

Figure 1-13. Adjusting Clutch Freeplay

GENERAL

The transmission should be drained and refilled with fresh fluid:

- At the 1,000 mile (1,600 km) initial service and at every 5,000 (8,000 km) service interval thereafter.

Transmission fluid capacity is 1.0 quart (0.95 liter). For best results, drain fluid while it is hot.

INSPECTION

1. Remove seat. See [2.29 SEAT](#).

WARNING

To protect against shock and accidental start-up of vehicle, disconnect the negative battery cable before proceeding. Inadequate safety precautions could result in death or serious injury.

2. Disconnect negative battery cable from battery.
3. Remove left footpeg support bracket. See [2.22 FOOTPEGS AND FOOTPEG SUPPORT BRACKETS](#).
4. Remove three TORX screws with washers (1) from clutch inspection cover (2). Remove clutch inspection cover from primary cover.
5. See [Figure 1-15](#). Inspect fluid level with motorcycle in upright position.
6. See [Figure 1-14](#). Install clutch inspection cover using three TORX screws with washers. Tighten in a crosswise pattern to 7-9 ft-lbs (9.5-12.2 Nm).
7. Install left footpeg support bracket. See [2.22 FOOTPEGS AND FOOTPEG SUPPORT BRACKETS](#).
8. Connect negative battery cable to battery. See [1.4 BATTERY](#).
9. Install seat. See [2.29 SEAT](#).

CHANGING TRANSMISSION FLUID

1. Raise rear wheel off floor using REAR WHEEL SUPPORT STAND (Part No. B-41174). This prevents transmission fluid from spilling out of the clutch inspection cover opening.
2. See [Figure 1-14](#). Position a suitable container under drain plug (3). Remove magnetic drain plug with O-ring and drain fluid.
3. Wipe any foreign material from the magnetic drain plug (3). Inspect O-ring for deterioration and replace as required. Reinstall drain plug with O-ring. Tighten drain plug to 14-30 ft-lbs (19.0-54 Nm).
4. Remove seat. See [2.29 SEAT](#).

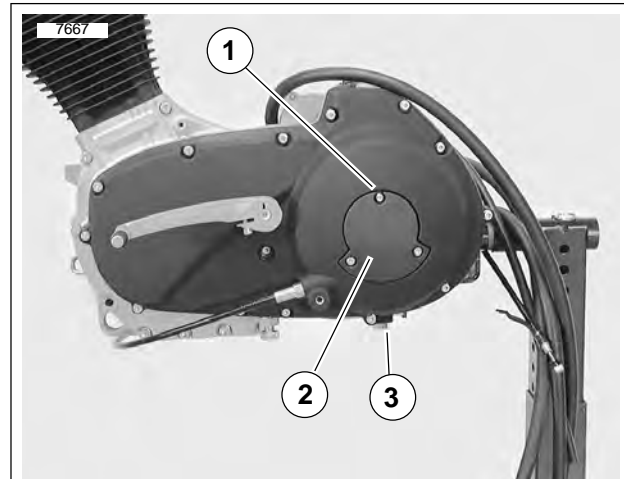

1. Torx Screws with washers (3)
2. Clutch Inspection Cover
3. Magnetic Drain Plug (with O-ring)

Figure 1-14. Primary Cover

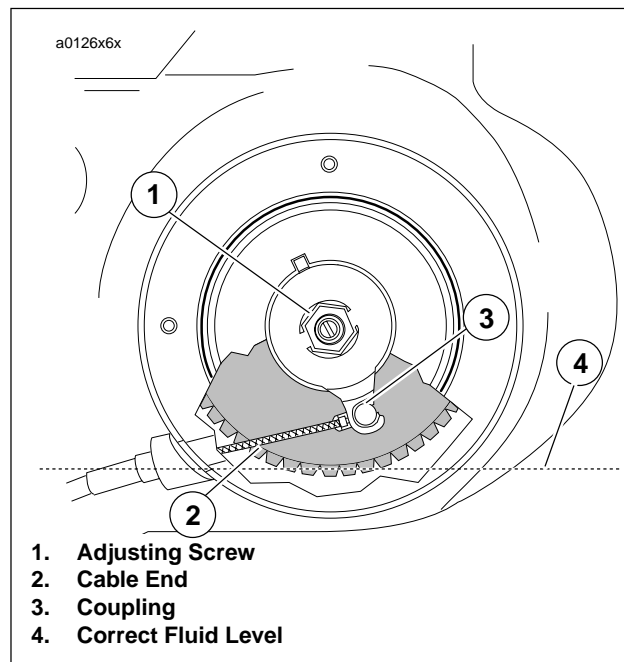

1. Adjusting Screw
2. Cable End
3. Coupling
4. Correct Fluid Level

Figure 1-15. Fluid Level

 **WARNING**

To avoid accidental start-up of vehicle and possible personal injury, disconnect the battery cables before proceeding. Inadequate safety precautions could result in death or serious injury.

5. Disconnect negative battery cable from battery.
6. Remove left footpeg support bracket. See [2.22 FOOTPEGS AND FOOTPEG SUPPORT BRACKETS](#).
7. Remove three TORX screws with washers (1) from clutch inspection cover (2). Remove clutch inspection cover from primary cover.

CAUTION

Do not overfill the primary chaincase with lubricant. Overfilling may cause rough clutch engagement, incomplete disengagement, clutch drag and/or difficulty in finding neutral at engine idle.

8. See [Figure 1-15](#). Add SPORT-TRANS FLUID (Part No. 98854-96 quart size; Part No. 98855-96 gallon size) as required until fluid level is even with bottom of clutch diaphragm spring.
9. See [Figure 1-14](#). Install clutch inspection cover using three TORX screws with washers. Tighten in a crosswise pattern to 7-9 ft-lbs (9.5-12.2 Nm).
10. Install footpeg support bracket. See [2.22 FOOTPEGS AND FOOTPEG SUPPORT BRACKETS](#).
11. Connect negative battery cable to battery. Tighten fastener to 60-96 **in-lbs** (6.8-10.9 Nm).
12. Install seat. See [2.29 SEAT](#).

 **WARNING**

After installing seat, pull upward on front of seat to be sure it is locked in position. If seat is loose, it could shift during vehicle operation, causing loss of control of vehicle and death or serious injury.

GENERAL

Drive belt tension is not adjustable. Replace the belt and sprocket if out of specification.

The drive belt and rear sprocket should be replaced:

- Every 15,000 miles (24,000 km)

NOTE

When a drive belt is replaced for any reason other than stone damage, it is recommended that the transmission and rear sprockets also be replaced to increase the longevity of the new drive belt. In the case of stone damage, inspect sprockets for damage and replace as required.

CLEANING

Use only mild soap and water spray solution to clean drive belt. Dry thoroughly. Do not immerse belt in solution.

INSPECTION

Checking Belt Deflection

NOTES:

Vehicle must be at room temperature and dry to obtain a correct measurement.

There are tight and loose spots during rear wheel rotation that affect belt deflection. For a more precise measurement, take three deflection readings, rotating the rear wheel between measurements. Average the three readings for a more precise measurement.

- Deflection should be measured with the rear wheel on the ground and a 160 lb. rider or equivalent weight sitting on the motorcycle.
- Maximum allowable deflection (measured with 10 lbs./4.5 kg. of force) is 0.5 in. (12.7 mm) at the bottom strand.

See [Figure 1-16](#). Using BELT TENSION GAUGE (Part No. **HD-35381**), apply 10 lbs (4.5 kg) of force at the midpoint of the belt's appropriate strand. The maximum allowable deflection is 0.5 in. (12.7 mm) at the bottom strand.

- Replace belt and drive sprocket that exceed maximum allowable deflection.

WARNING

Check alignment of the rear wheel and/or brake calipers when servicing motorcycle. A misaligned rear wheel and/or brake caliper could cause the rear brake disc to bind resulting in loss of control and death or serious injury.

Rear Sprocket

1. See [Figure 1-17](#). Inspect each tooth of rear sprocket for:
 - a. Major tooth damage.
 - b. Gouges caused by hard objects.

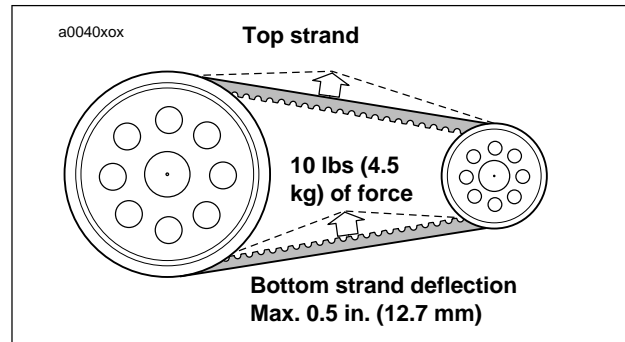

Figure 1-16. Measuring Belt Deflection

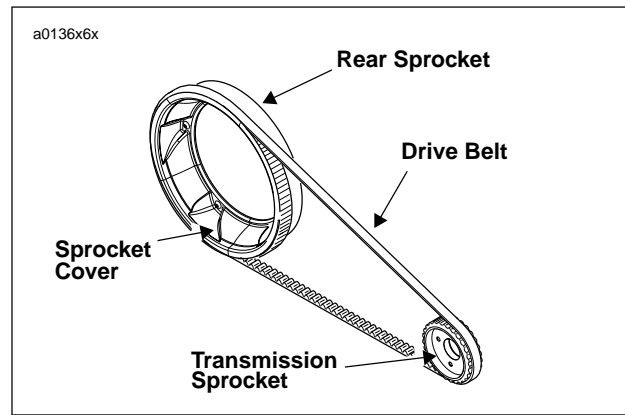

Figure 1-17. Drive Belt Assembly

2. Replace rear sprocket if major tooth damage exists.

Drive Belt

See [Figure 1-18](#). Inspect drive belt for:

- Cuts or unusual wear patterns.
- Outside edge bevelling (8). Some bevelling is common, but it indicates that sprockets are misaligned.
- Outside ribbed surface for signs of stone puncture (7). If cracks/damage exists near edge of belt, replace belt immediately. Damage to center of belt will require belt replacement eventually, but when cracks extend to edge of belt, belt failure is imminent.
- Inside (toothed portion) of belt for exposed tensile cords (normally covered by nylon layer and polyethylene layer). This condition will result in belt failure and indicates worn transmission sprocket teeth. Replace belt and transmission sprocket.
- Signs of puncture or cracking at the base of the belt teeth. Replace belt if either condition exists.
- Replace belt if conditions 2, 3, 6 or 7 (on edge of belt) exist.

NOTE

Condition 1 may develop into 2 or 3 over time. Condition 1 is not grounds for replacing the belt, but it should be watched closely before condition 2 develops which will require belt replacement.

a0147x6x

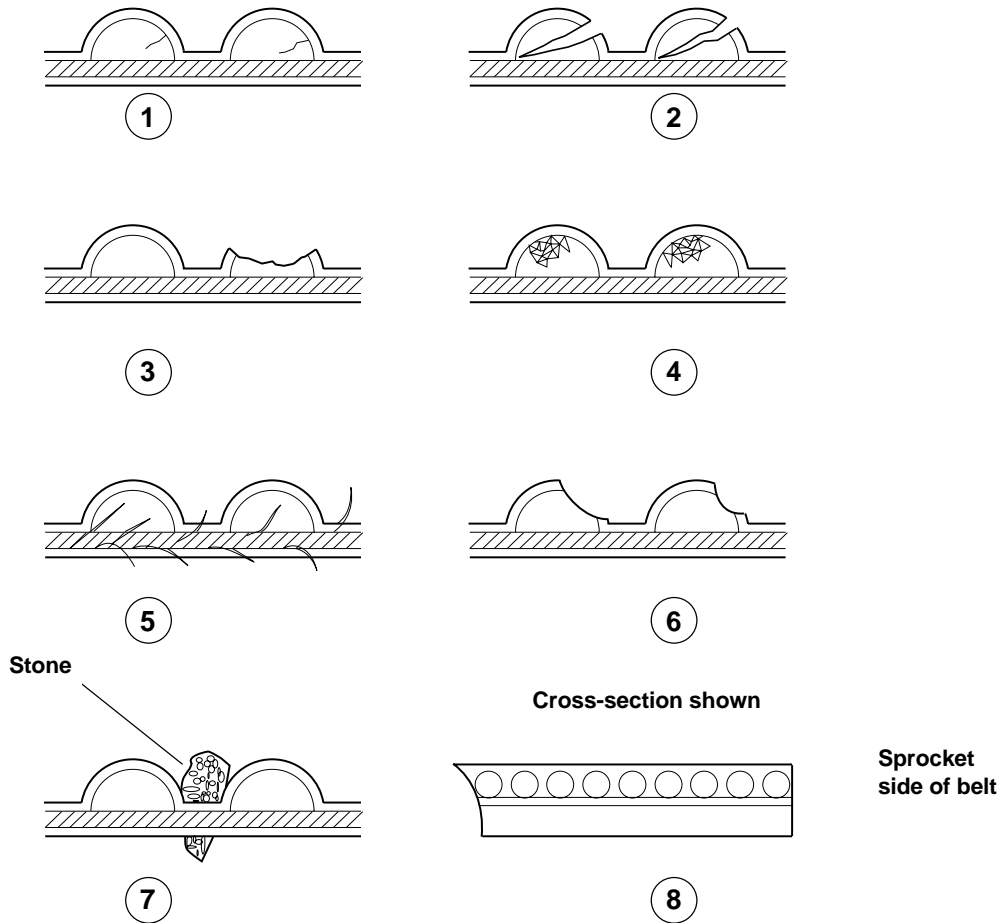

Figure 1-18. Drive Belt Wear Patterns

Table 1-5. Drive Belt Wear Analysis

PATTERN IN FIGURE 1-18.	CONDITION	REQUIRED ACTION
1	Internal tooth cracks (hairline)	OK to run, but monitor condition
2	External tooth cracks	Replace belt
3	Missing teeth	Replace belt
4	Chipping (not serious)	OK to run, but monitor condition
5	Fuzzy edge cord	OK to run, but monitor condition
6	Hook wear	Replace belt
7	Stone damage	Replace belt if damage is on the edge
8	Bevel wear (outboard edge only)	OK to run, but monitor condition

DRIVE BELT AND REAR SPROCKET REPLACEMENT

1. Remove seat. See 2.29 SEAT.

WARNING

To protect against shock and accidental start-up of vehicle, disconnect the negative battery cable before proceeding. Inadequate safety precautions could result in death or serious injury.

2. Disconnect the negative battery cable from the battery.
3. Raise rear wheel off floor using REAR WHEEL SUPPORT STAND (Part No. B-41174).
4. See Figure 1-19. Place rod or screwdriver through axle hole. Loosen rear axle nut (1) (metric).
5. Remove nut, lockwasher, and flat washer.
6. Pull axle out. Remove right side spacer.
7. Slide carrier with caliper off rotor.
8. Remove left side spacer.
9. Move wheel forward and slide belt off.
10. Remove sprocket cover and five washers from sprocket.
11. Remove and discard sprocket. Discard five washers.

WARNING

Always wear proper eye protection and gloves when working with compressed air. Compressed air may eject debris with enough force to cause injury. Inadequate safety precautions may result in death or serious injury.

12. Clean residual loctite from threads in wheel sprocket towers with a suitable non-flammable solvent. Dry with compressed air.
13. Remove three TORX bolts, washers and front sprocket cover from right side of motorcycle. NOTE: It may be necessary to compress suspension to gain access to front sprocket cover TORX bolt.
14. Remove two TORX screws and washers from right side of rear inner fender. Carefully bend rear inner fender upwards and remove drive belt. Discard drive belt.
15. Position **new** drive belt over transmission drive sprocket.
16. Install rear inner fender with two TORX screws and washers. See 2.24 FENDERS.
17. Install front sprocket cover with three TORX screws and washers. See 2.23 SPROCKET COVER.
18. Position rear sprocket on rear wheel with mounting holes aligned.

WARNING

Use only new P/N BA0511.2Z hardened washers between sprocket cover and sprocket. Failure to use hardened washers could cause sprocket to fail. Drive sprocket failure could lead to loss of control of vehicle which could result in death or serious injury.

19. Place **new** hardened washers on sprocket and install **new** sprocket cover over washers and sprocket.
20. Install sprocket and sprocket cover with five **new** sprocket bolts. Tighten bolts to 28-31 ft-lbs (38-42 Nm).

21. Place wheel centrally in the swingarm. Slide wheel far enough forward to slip belt over sprocket and rest belt on sprocket inboard of the teeth.

NOTE

Do not place belt on sprocket teeth at this time. Alignment of parts will be difficult. Resting belt next to teeth allows slack for easier alignment of wheel assembly.

22. Hold left side spacer in place and slide caliper and carrier over rotor.
23. Slide axle through washer, swing arm, carrier, left side spacer and wheel assembly.
 - a. See Figure 1-20. Hold right side spacer in place.
 - b. Insert axle through right side spacer and swingarm.
 - c. Install flat washer, lockwasher and axle nut.
24. Place screwdriver or rod through axle hole and torque rear axle nut to 48-52 ft-lbs (65.1-70.5 Nm).
25. Slide belt on sprocket teeth by rotating wheel to "walk" belt onto teeth.
26. Lower motorcycle rear wheel.
27. Connect negative battery cable to battery. Tighten fastener to 60-96 in-lbs (6.8-10.9 Nm).
28. Install seat. See 2.29 SEAT.

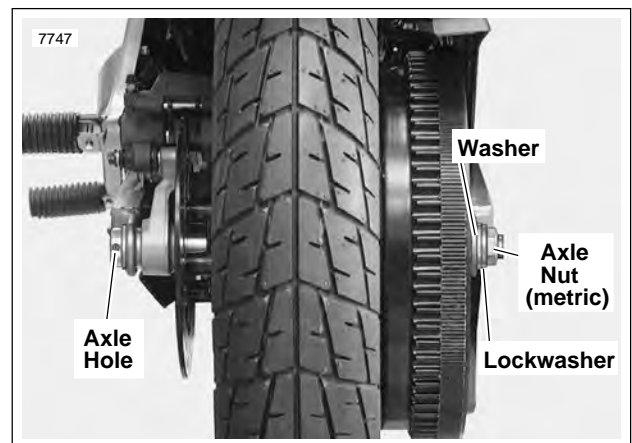

Figure 1-19. Rear Wheel Mounting

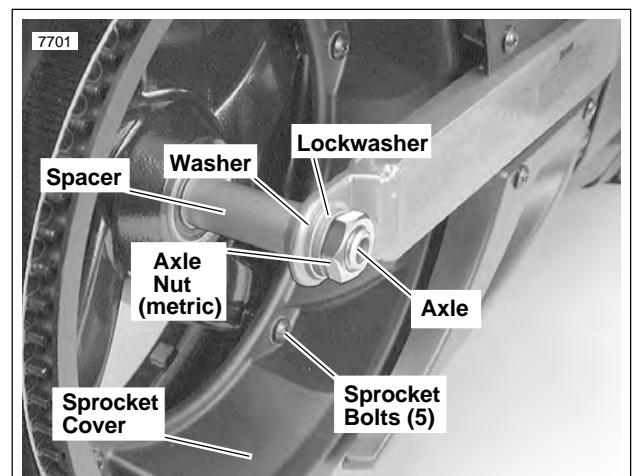

Figure 1-20. Rear Axle, Right Side

GENERAL

Adjust primary chain tension:

- At the 1,000 mile (1,600 km) initial service interval.
- At every 2,500 mile (4,000 km) interval thereafter.

ADJUSTMENT

See [Figure 1-21](#). Buell Blast Models are shipped with a spacer between the primary chain limiting screw and the locknut. The spacer is used to quickly get proper adjustment during production. This spacer should be removed and discarded at the first adjustment interval.

1. See [Figure 1-22](#). Back-off locknut and chain limiting screw. Remove spacer.

IMPORTANT NOTE

Be certain to use **Inch-Pound Wrench**. Chain adjuster shoe can be damaged by excessive force.

2. See [Figure 1-23](#). Tighten chain limiting screw to 24 in-lbs.
3. Back-off chain limiting screw 3/4 turn (4 1/2 "flats").
4. Hold chain limiting screw while tightening jam nut.

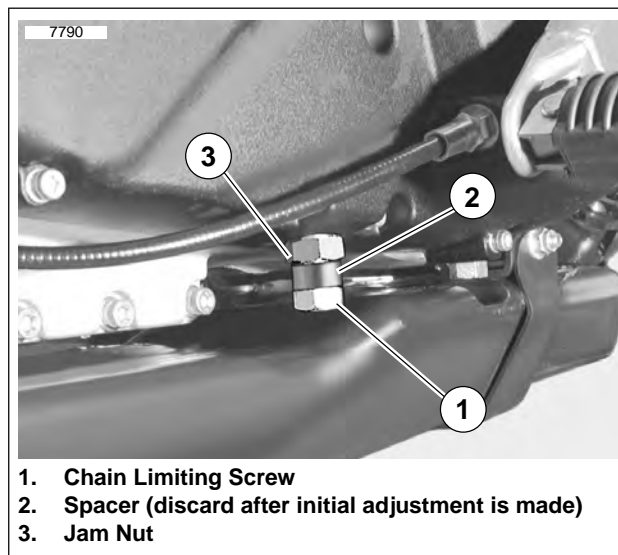

Figure 1-21. Adjustment Nut-with Spacer

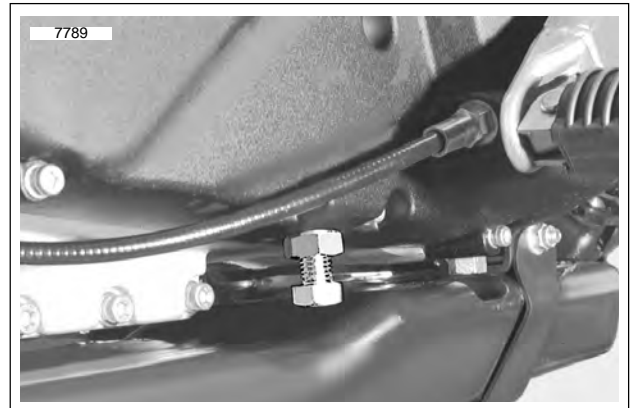

Figure 1-22. Chain Limiting Screw-without Spacer

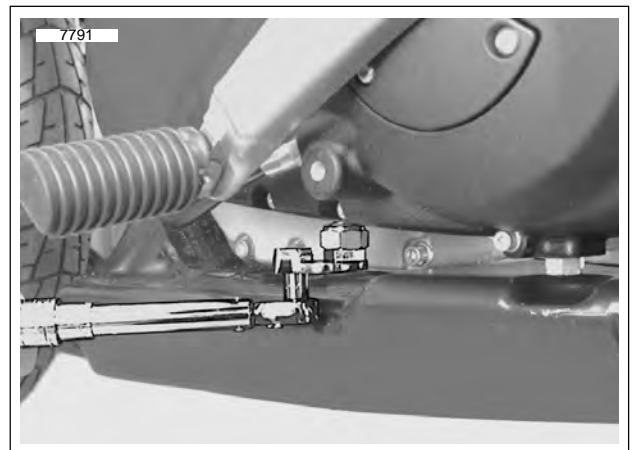

Figure 1-23. Tightening Chain Limiting Screw

REAR SHOCK ABSORBER

1.13

GENERAL

Inspect rear shock absorber for proper operation and for oil leaks. Inspect rubber shock eye bushings for deterioration:

- At every 10,000 mile (16,000 km) service interval.

NOTE

Rear shock absorber contains no user serviceable parts.
Replace the shock absorber if it fails.

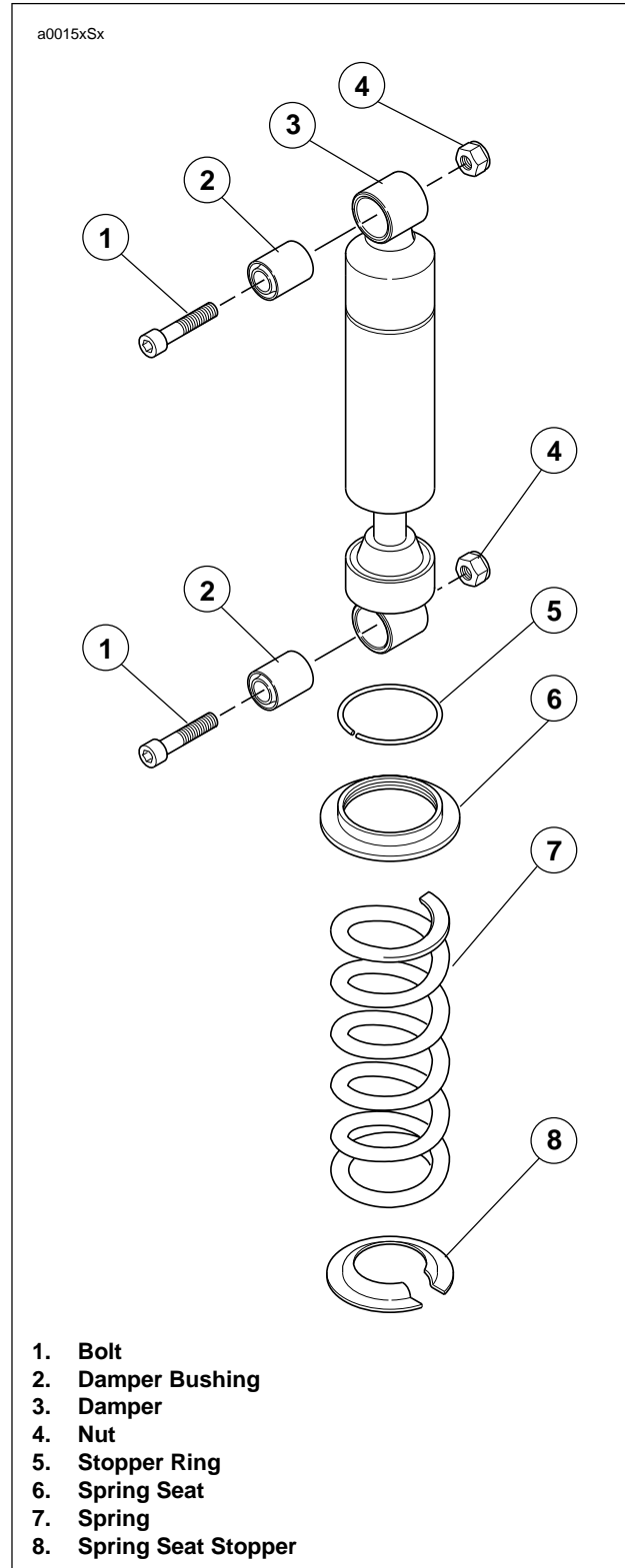

Figure 1-24. Rear Shock Absorber Assembly

GENERAL

Drain and refill the front forks with fresh fork oil:

- At every 20,000 mile (32,000 km) service interval.

FORK OIL CHANGE

1. Remove front forks. See [2.18 FRONT FORK](#).
2. See [Figure 1-25](#). Clamp the fork in a vise with front fork holding tool (part no. B-4177).



Figure 1-25. Clamping the Fork

3. See [Figure 1-26](#). Remove slider tube cap.



Figure 1-26. Slider Tube Cap

4. See [Figure 1-27](#). Push down on the B-spring seat (O-ring included) and remove the stopper ring and spring seat.



Figure 1-27. B-Spring Seat

5. See [Figure 1-28](#). Remove the spring collar, lower spring seat and spring from slider tube.
6. See [Figure 1-29](#). Remove the fork oil by pumping the fork leg and rod 8-10 times until the rod moves freely.

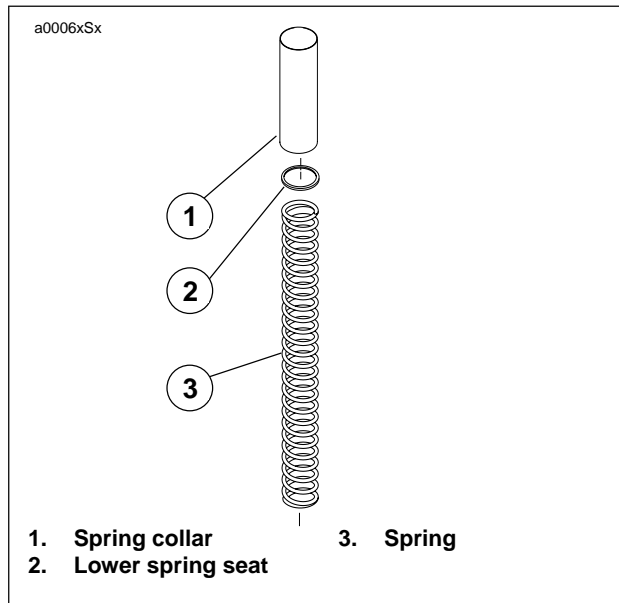

Figure 1-28. Removing Sub-Assembly



Figure 1-29. Pumping Fork Oil

NOTE

The recommended fork oil is hydraulic fork oil type "E".

7. Pour 9.2 oz. fork oil into fork.
8. Install lower spring seat and spring collar.
9. Coat a new O-ring with fork oil or sealing grease.
10. Install new O-ring onto spring seat.
11. See [Figure 1-30](#). Push down on spring seat past groove to install stopper ring. Stopper ring will lock into groove when installed correctly.
12. See [Figure 1-31](#). Install slider tube cap.
13. Install front forks. See [2.18 FRONT FORK](#).



Figure 1-30. Compressing Spring Seat



Figure 1-31. Slider Tube Cap

GENERAL

Check steering head bearings:

- At the 1000 mile (1600 km) initial service and at every 2,500 mile (4,000 km) service interval thereafter.
- When storing or removing the motorcycle for the season.

Lubricate and adjust steering head bearings:

- At every 20,000 mile (32,000 km) service interval. Lubricate the steering head bearings with [WHEEL BEARING GREASE \(Part No. 99855-89\)](#)

INSPECTION

With motorcycle front end raised off of floor, check to make sure front fork turns freely, without any binding or interference. Also check to make sure there is no appreciable front to rear fork shake indicating excessive bearing looseness.

1. Detach clutch cable at handlebar.
2. Remove seat and fuel tank. See [4.2 FUEL TANK COVER/FUEL TANK](#).
3. Attach lifting straps to frame tube behind steering neck. Raise front wheel off floor using a floor hoist and lifting straps. Turn front wheel to full right lock.
4. See [Figure 1-32](#). Attach a spring scale into the hole in the front axle. With scale 90 degrees from fork leg, pull front wheel to center position. It should take **6.5-7 lbs (2.9-3.2 kg)** to pull front wheel to center.
5. Attach clutch cable to handlebar.

NOTE

Check that clutch and throttle cables do not bind when measuring bearing resistance.

ADJUSTMENT

1. Detach clutch cable at handlebar.
2. Remove seat and fuel tank. See [4.2 FUEL TANK COVER/FUEL TANK](#).
3. Attach lifting straps to frame backbone behind steering neck. Raise front wheel off floor using a floor hoist and lifting straps.
4. Turn front wheel to full right lock.
5. See [Figure 1-32](#). Attach a spring scale. Pull front wheel to center position. It should take **6.5-7 lbs (2.9-3.2 kg)** to pull front wheel to center.
6. See [Figure 1-33](#). To adjust:
 - a. Loosen both pinch screws on lower triple clamp.
 - b. Loosen center cap pinch screw on upper triple clamp.
 - c. Loosen cap nut, then tighten to 48-52 ft-lbs (65-71 Nm) to seat bearing. Loosen cap nut and retighten to 28-32 ft-lbs (38-43 Nm).
7. Recheck tension using spring scale. See Step 5.
8. Tighten both lower triple clamp pinch screws to 22-29 ft-lbs (30-39 Nm).

9. Tighten center cap pinch screw to 7-10 ft-lbs (10-14 Nm).



Figure 1-32. Steering Head Bearing Check

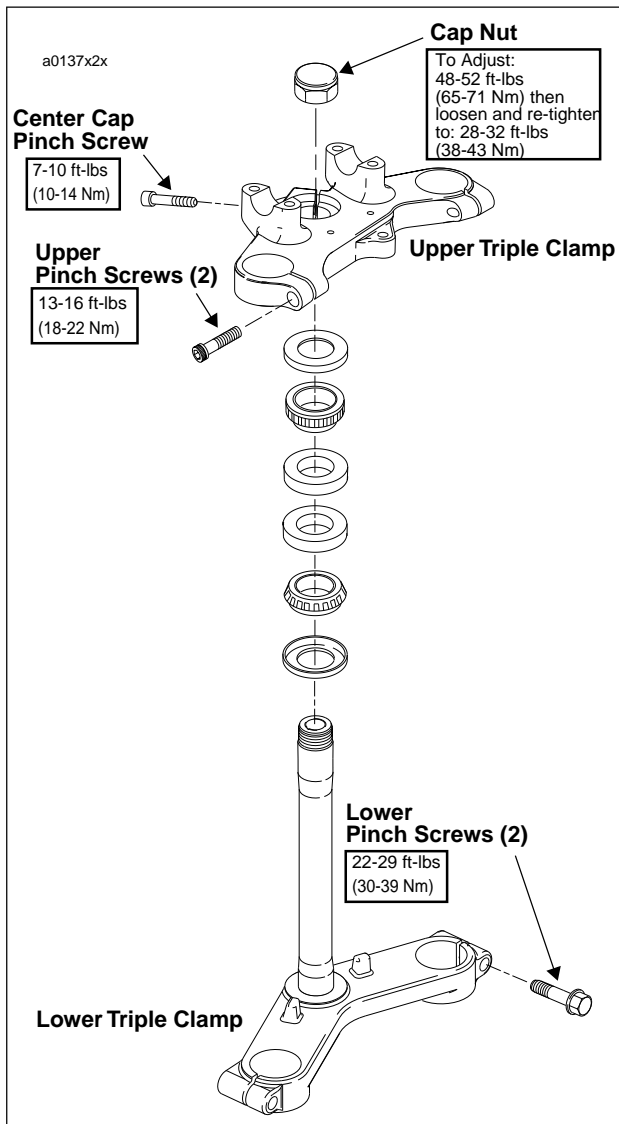

Figure 1-33. Fork Stem and Bracket Assembly

GENERAL

Change spark plug:

- At every 10,000 mile (16,000 km) service interval. Use only Harley-Davidson No. 10R12 plug (Part No. 27661-00Y) as a replacement.

INSPECTION

1. Disconnect cable from both spark plug by pulling on rubber boot (not cable).
2. Remove spark plug and examine.
3. See [Figure 1-34](#). Compare your observations of the plug deposits with the descriptions provided below.
 - a. A wet, black and shiny deposit on plug base, electrodes and ceramic insulator tip indicates an oil fouled plug. The condition may be caused by one or more of the following: worn pistons, worn piston rings, worn valves, worn valve guides, worn valve seals, a weak battery or a faulty ignition system.
 - b. A dry, fluffy or sooty black deposit indicates a carburetor air-fuel mixture that is too rich, engine idling for excessive periods of time and/or enrichener usage for excessive periods of time.
 - c. A light brown, glassy deposit indicates an overheated plug. This condition may be accompanied by cracks in the insulator or by erosion of the electrodes and is caused by an air-fuel mixture that is too lean, a hot-running engine, valves not seating or improper ignition timing. The glassy deposit on the spark plug is a conductor when hot and may cause high-speed misfiring. A plug with eroded electrodes, heavy deposits or a cracked insulator must be replaced.
 - d. A plug with a white, yellow, tan or rusty brown powdery deposit indicates balanced combustion. Clean off spark plug deposits at regular intervals.
4. If the plug requires cleaning between tune-ups and replacement plug is not available, proceed as follows:
 - a. De-grease firing end of spark plug using ELECTRICAL CONTACT CLEANER. Dry plug with compressed air.
 - b. Use a thin file to flatten spark plug electrode. A spark plug with sharp edges on its electrodes requires 25%-40% less firing voltage than one with rounded edges.
5. If the plug cannot be cleaned, replace with HD No. 10R12 spark plug (Part No. 27661-00Y).
6. Check electrode gap with a wire-type feeler gauge. Gap should be 0.038-0.043 in. (0.97-1.09 mm).
7. Apply LOCTITE ANTI-SEIZE to threads of spark plug. Install and tighten to 11-18 ft-lbs (14.9-24.4 Nm).
8. Connect spark plug cable. Verify that cable is securely connected to ignition coil and spark plug.



Figure 1-34. Typical Spark Plug Deposits

GENERAL

Inspect the air cleaner filter element:

- At every 10,000 mile (16,000 km) service interval. Inspect the filter element more frequently if operated in dusty conditions.

Replace the air cleaner filter element:

- Every 30,000 miles (48,000 km) or as required.

REMOVAL

1. Release five latches around perimeter of air box cover. See Figure 1-35.
2. Remove single Phillips screw at bottom of air box cover (7 o'clock position).
3. Pull cover from air box.
4. Pull conical shaped filter from air box.
5. Squeeze wings on spring clamp with pliers and pull clean air inlet hose from fixed position on allen head screw (gold) at top of venturi ring. Remove screw with spacer.
6. Remove remaining two allen head screws to free venturi ring from carburetor flange.
7. Remove hex screw at bottom of air box (6 o'clock position) to release bracket from crankcase hole.
8. Moving to left side of vehicle, remove two flange bolts to release side of air box from triangular shaped bracket. Do not remove bottom bolt to crankcase. See Figure 1-36.

CAUTION

Do not take bolt in and out of the crankcase unless necessary. Since the potential for stripping always exists during removal and installation, leave the bolt intact to avoid possible damage to the crankcase.

9. Returning to the right side of the vehicle, carefully pull out air box. When partially removed, detach clean air inlet hose from middle fitting on 3-way connector.
10. Remove gasket from inboard side of air box. Discard gasket.

CLEANING AND INSPECTION

1. Thoroughly clean air cleaner cover and backplate.
2. Replace the filter element if damaged or if filter media cannot be adequately cleaned.

WARNING

Do not use gasoline or solvents to clean the filter element. Volatile or flammable cleaning agents may cause an intake system fire, which could result in death or serious injury.

3. Wash the filter element (and hose connections) in warm, soapy water. To remove soot and carbon, soak element for 30 minutes in warm water with mild detergent.

WARNING

Compressed air can pierce the skin and cause injury. Never use your hand to check for leaks or to determine air flow rates. Wear safety glasses to shield your eyes from flying dirt and debris. Failure to comply could result in death or serious injury.

4. Dry the filter element using low pressure compressed air (32 psi/221 kPa maximum). Rotate the element while moving air nozzle up and down the element exterior. Do not rap the element on a hard surface.
5. Hold the filter element up to a strong light source. The element can be considered sufficiently clean if light is uniformly visible through the media.
6. Inspect all hose connections for cuts, tears, holes or signs of deterioration. Replace as necessary. Direct compressed air through hoses to verify that they are not plugged.

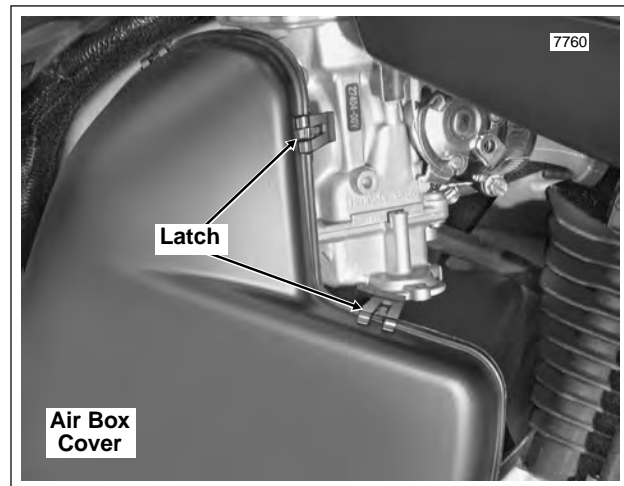

Figure 1-35. Release Air Box Cover Latches

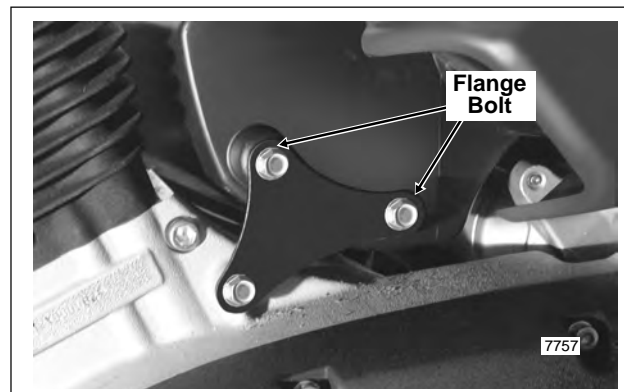

Figure 1-36. Remove Air Box From Bracket

INSTALLATION

1. Obtain a **new** carburetor gasket. Remove the protective paper and place the sticky side of the gasket against the back of the airbox. Use care to align the holes in the gasket with the slotted holes in the airbox.
2. Standing on the right side of the vehicle, start air box into opening below and to the rear of the carburetor. When partially installed, push clean air inlet hose onto middle fitting of 3-way connector.
3. Moving to opposite side of vehicle, apply a small dab of Loctite Low Strength Threadlocker 222 (Purple) to threads of two flange bolts. Slide bolts through top two holes of triangular bracket and install into left side of air box. Alternately tighten screws to 3-5 ft-lbs (4.1-6.8 Nm).
4. Returning to right side of vehicle, align slots in air box with holes in carburetor flange.
5. Apply a small dab of Loctite Medium Strength Threadlocker 243 (blue) to threads of two short allen head screws. With the flat edge at the top, align holes in venturi ring with holes in carburetor flange. Install screws in the 5 o'clock and 9 o'clock positions. Alternately tighten screws to 18-22 **in-lbs** (20.-2.5 Nm).
6. Slide spacer onto longer allen head screw (gold), if removed. Apply a small dab of Loctite Medium Strength Threadlocker 243 (blue) to threads of screw and install into remaining hole in venturi ring (2 o'clock position). Tighten screw to 18-22 **in-lbs** (20.-2.5 Nm).
7. Squeeze wings on spring clamp with pliers and push free end of clean air inlet hose over head of gold screw (and spacer) to fix position. See [Figure 1-37](#).
8. Apply one drop of Loctite High Strength Threadlocker 262 (red) to threads of hex screw. Install screw at bottom of air box (6 o'clock position) to secure air box bracket to crankcase hole. Tighten screw to 10-12 ft-lbs (13.6-16.3 Nm).
9. With the larger OD inboard, install conical shaped filter into air box.
10. Taking note of index pin on inboard side of cover and small depression at tip of cone, position cover onto air box so that pin engages depression. See [Figure 1-38](#).
11. Lock five latches around perimeter of air box cover.
12. Install Phillips screw at bottom of air box cover (7 o'clock position) to secure cover to air box. Tighten screw to 4-6 **in-lbs** (0.5-0.7 Nm).

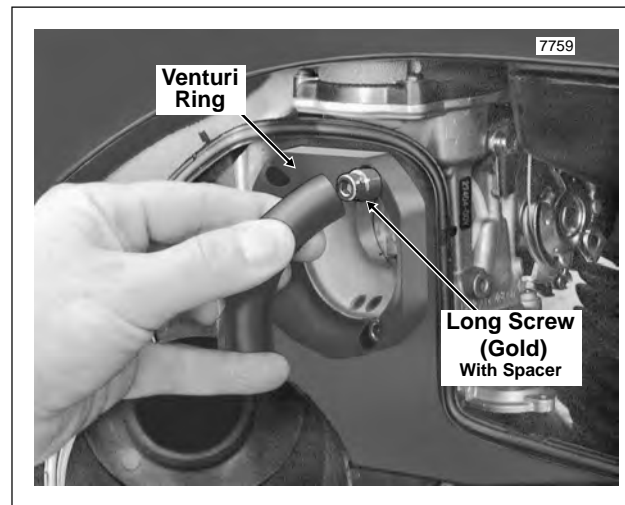

Figure 1-37. Fix Hose End Onto Allen Head Screw

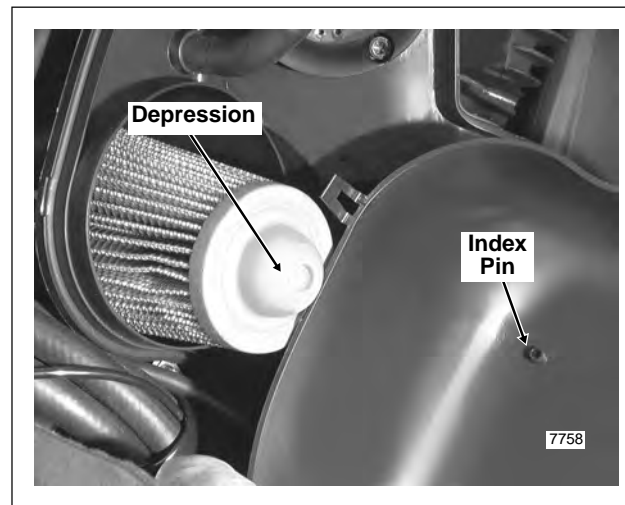

Figure 1-38. Install Air Box Cover

GENERAL

Lubricate throttle control cables with LUBIT-8 TUFOIL CHAIN AND CABLE LUBE (Part No. 94968-85TV):

- Every 5,000 mile (8,000 km) service interval.

Check throttle cable adjustment:

- Before every ride.
- At the 1,000 mile initial service interval and at every 2,500 mile (4,000 km) service interval thereafter.

ADJUSTMENT

WARNING

Throttle cables must not pull tight when handlebars are turned fully to left or right fork stops. Be sure wires and throttle cables are clear of fork stops at steering head so they will not be pinched when fork is turned against stops. Steering must be smooth and free with no binding or interference. Anything interfering with carburetor operation may cause loss of vehicle control which could result in death or serious injury.

With engine running, turn handlebars through full range of travel. If engine speed changes during this maneuver, adjust throttle cables as follows:

1. See [Figure 1-39](#). Slide rubber boot (5) off cable adjuster (4).
2. Loosen cable adjuster lock (3) on each adjuster.
3. Turn adjusters (4) in direction which will shorten cable housings to minimum length.
4. Point front wheel straight ahead. Twist throttle control grip to fully open position; hold in position.
5. Turn adjuster (4) on throttle control cable (1) until throttle cam stop touches carburetor stop plate. Tighten adjuster lock on throttle control cable (1) adjuster (4); release throttle control grip.
6. Turn handlebars fully to right. Turn adjuster (4) on idle control cable (2) until end of cable housing just touches the carburetor cable guide.
7. Twist and release throttle control grip a few times. Carburetor throttle must return to idle position each time throttle grip is released. If this is not the case, turn adjuster (4) on idle control cable (2) (shortening cable housing) until throttle control functions properly.
8. Tighten adjuster lock (3) on idle control cable (2) adjuster (4). Recheck operation of throttle control (Step 7).
9. Slide rubber boot (5) over each cable adjuster (4). Recheck engine slow idle speed; adjust if required.
10. Install air cleaner assembly. See [4.3 AIR CLEANER](#).

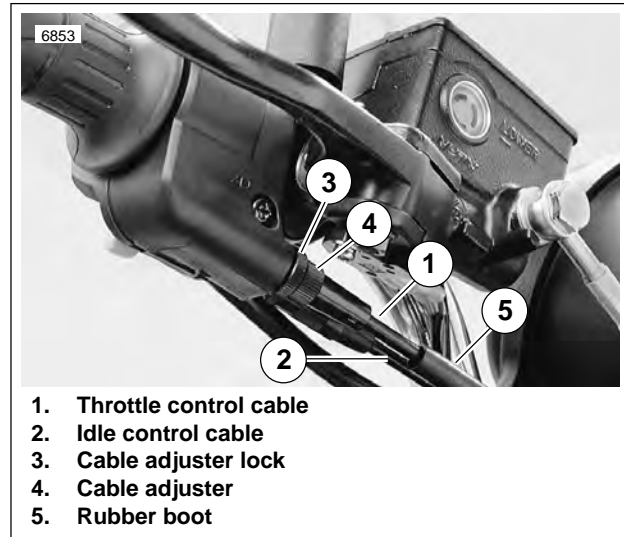

Figure 1-39. Throttle Control Cables

GENERAL

Check ignition timing:

- Every 10,000 mile (16,000 km) service interval.

Check engine idle speed (after bike has warmed up):

- At the 1,000 mile (1,600 km) initial service and every 2,500 mile (4,000 km) service interval thereafter.

DYNAMIC TIMING

NOTE

Use static timing method if inductive timing light is not available. See 7.8 IGNITION MODULE/ CAM POSITION SENSOR.

Dynamic Timing

1. Remove hex socket timing plug from timing inspection hole, which is located on right crankcase half and centered below engine cylinders. Install TIMING MARK VIEW PLUG (Part No. HD-96295-65D) into timing inspection hole. Make sure view plug does not touch flywheel.
2. Connect leads of INDUCTIVE TIMING LIGHT (Part No. HD-33813) to spark plug cable, battery positive (+) terminal, and suitable ground.
3. Make sure vacuum hose is properly installed at carburetor. Start engine.
4. Make sure sidestand is up and transmission is in NEUTRAL.
5. Set engine speed to 1200 rpm.

CAUTION

When checking ignition timing, always check at the rpm listed. Failure to do so may result in running engine with too much spark advance, and may cause extreme engine knock and engine failure.

6. See Figure 1-40. Timing light will flash each time an ignition system spark occurs. Aim timing light into timing inspection hole. The advance timing mark (two dots) should be centered in timing inspection hole. If this is the case, ignition timing is properly adjusted. Go to Step 11. If timing mark is not centered or is not visible in the timing inspection hole, see to Steps 7-12.
7. See Figure 1-41. Drill hole in location shown and remove outer timer cover, if not removed.
8. Loosen module plate screws just enough to allow sensor plate to be rotated using a screwdriver in the plate's notch.
9. With timing light aimed into inspection hole, rotate module plate until advance timing mark is centered in timing inspection hole (as shown in Figure 7-17).
10. See Figure 1-41. Tighten module plate screws to 15-30 in-lbs (1.7-3.4 Nm)
11. Install new outer cover, if removed.
12. Remove TIMING MARK VIEW PLUG from timing inspection hole. Install hex socket timing plug. Torque timing plug to 10-15 ft. lbs (14-21 Nm).

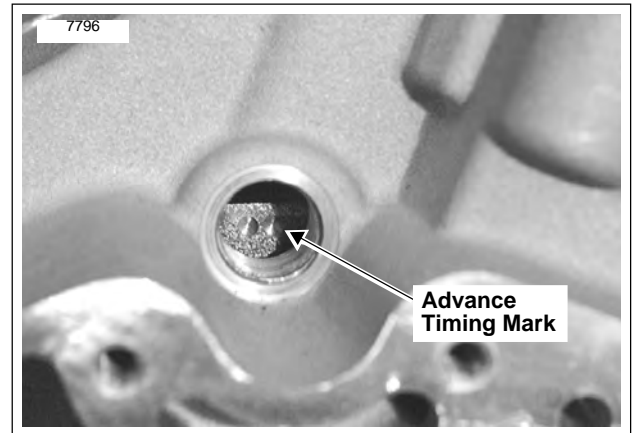

Figure 1-40. Dynamic Ignition Timing

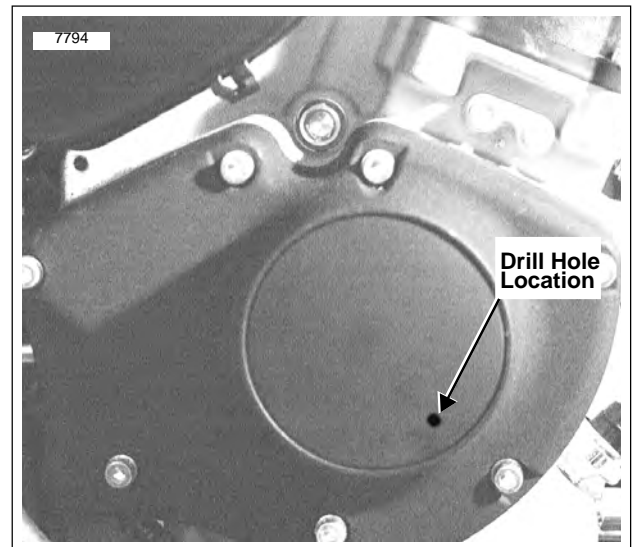

Figure 1-41. Drilling/Removing Timer Cover

IDLE SPEED ADJUSTMENT

NOTE

The Blast P3 is equipped with an auto-enrichener that automatically increases the idle speed and richens the fuel mixture at startup. To correctly set the idle speed, the auto-enrichment cycle must be complete (idle speed has slowed from startup).

Check idle speed adjustment:

- **After** the bike is warmed up.

Regular idle speed is 1200 RPM. Set idle speed using remote idle adjustment screw. See [Figure 1-43](#).

1. Perform dealer road test first.

NOTE:

Be sure the engine is warmed up to normal operating temperature. Be aware that because there are variations in individual components, it is possible for a properly warmed-up engine to idle at 2000 RPM.

2. See [Figure 1-42](#). The ignition coil cable is located on the left side of the bike behind the fuel supply valve. Place HAND-HELD TACHOMETER (SNAP-On Part No. ONO-SE-1100) on ignition coil cable.
3. Press the tachometer button to obtain a reading for the current RPM.
4. See [Figure 1-43](#). Set engine speed by turning the idle adjuster clockwise to increase speed or counter clockwise to decrease speed.
5. Repeat steps 1, 2 and 3 until the tachometer has a reading of 1200 RPM.
6. Turn the ignition switch to off position.

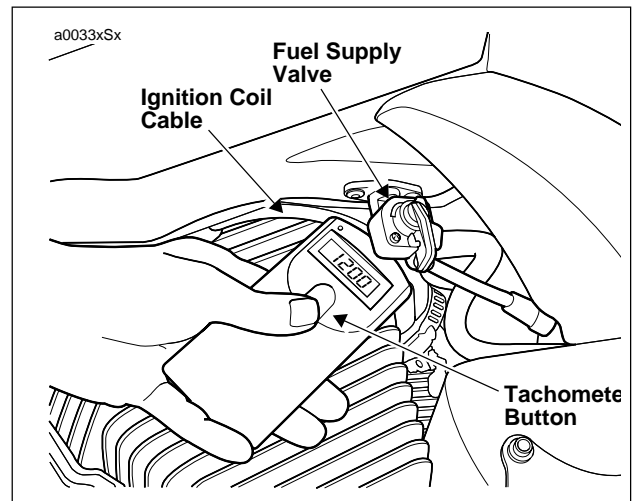

Figure 1-42. Checking RPM

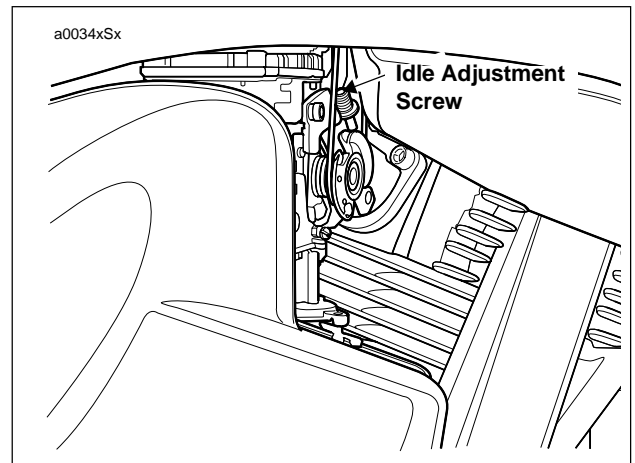

Figure 1-43. Adjusting Idle Speed

GENERAL

Inspect fuel supply valve, fuel lines and fittings for leaks:

- At the 1,000 mile (1,600 km) initial service and every 2,500 mile (4,000 km) service interval thereafter.

Inspect and clean the fuel filter strainer:

- At every 20,000 mile (32,000 km) service interval. Replace as required.

REMOVAL

⚠ WARNING

Gasoline is extremely flammable and highly explosive. When servicing the fuel system, do not smoke or allow open flame or sparks in the vicinity. Inadequate safety precautions could result in death or serious injury.

1. Remove seat. Depress latch at bottom and pull seat up and back to remove.

⚠ WARNING

To protect against shock and accidental start-up of vehicle, disconnect the negative battery cable before proceeding. Inadequate safety precautions could result in death or serious injury.

2. Unthread bolt and remove battery negative cable (black) from battery negative (-) terminal.
3. Drain fuel tank as follows:
 - a. Rotate handle on the fuel supply valve to the fully vertical position to shut the gasoline supply to the carburetor OFF. See A of Figure 1-44.

⚠ WARNING

Some gasoline will drain from the outlet hose when disconnected from the fuel valve. Thoroughly wipe up any spilt fuel immediately. Dispose of rags in a suitable manner. Gasoline is extremely flammable and highly explosive. Inadequate safety precautions could result in death or serious injury.

- b. Turn slotted screw to loosen band clamp on outlet fitting at side of fuel valve. Pull hose from fitting.
- c. Attach length of spare hose to outlet fitting. Place free end of hose into a suitable container.
- d. Rotate handle of fuel supply valve to RES(ERVE) to start the flow of fuel. See C of Figure 1-44.
- e. Once the fuel tank is completely drained, rotate handle of fuel supply valve to OFF. Remove spare hose from outlet fitting.

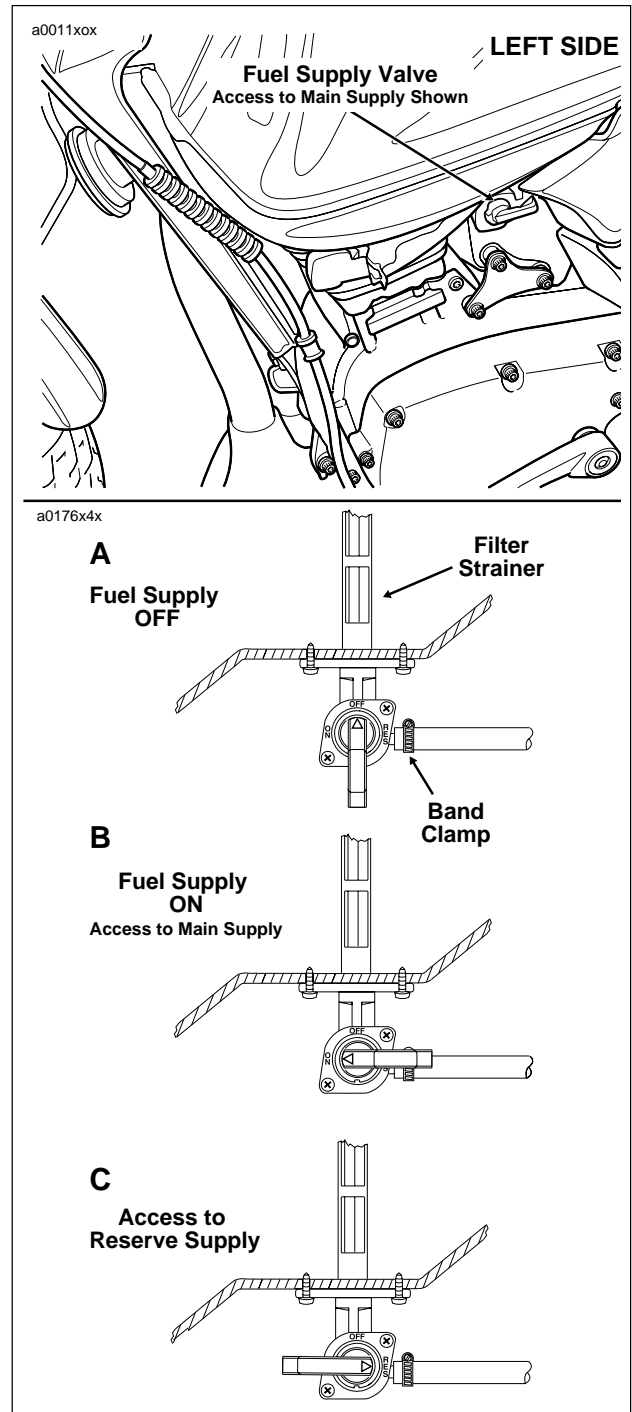

Figure 1-44. Fuel Supply Valve

⚠ WARNING

Even with the fuel tank completely drained, a small amount of gasoline may leak from the bore when the fuel supply valve is loosened or removed. Thoroughly wipe up any spilt fuel immediately. Dispose of rags in a suitable manner. Gasoline is extremely flammable and highly explosive. Inadequate safety precautions could result in death or serious injury.

4. Remove two allen head screws from fuel valve and pull assembly from fuel tank bore.
5. Remove O-ring from flange of fuel valve assembly. Discard O-ring.
6. Carefully unthread fuel filter strainer from fuel valve assembly.

CLEANING AND INSPECTION

Clean strainer using a suitable solvent. Discard strainer if any damage is found.

INSTALLATION

1. Carefully thread fuel filter strainer onto fuel valve assembly.
2. Install **new** O-ring into groove on flange of fuel valve assembly.
3. Insert fuel valve assembly into fuel tank bore and install two allen head screws. Alternately tighten screws to 6-10 **in-lbs** (0.7-1.1 Nm).
4. Push hose onto outlet fitting at side of fuel valve. Turn slotted screw to tighten band clamp.
5. Verify that handle of fuel supply valve is in the OFF position and fill the fuel tank.
6. Rotate handle of fuel supply valve to ON and carefully inspect for leaks. Return the valve to the OFF position when finished.
7. Insert bolt through battery negative cable (black) into threaded hole of battery negative (-) terminal. Tighten bolt to 60-96 **in-lbs** (6.8-10.9 Nm).
8. Position seat on frame backbone, so that tongue at bottom engages slot in frame weldment. Push down on rear of seat until spring-loaded latch fully engages groove of seat pin.

⚠ WARNING

Pull up on seat to verify that it is properly secured, front and rear. A loose seat may shift during vehicle operation and startle the rider, possibly causing loss of vehicle control that could result in death or serious injury.

STARTER INTERLOCK AND ELECTRICAL SWITCHES 1.21

GENERAL

Lubricate sidestand with LOCTITE LUBRIPLATE or LITHIUM GREASE:

- At every 5,000 mile (8,000 km) service interval.

Inspect all electrical equipment and switches, including starter interlock for proper operation:

- At the 1,000 mile (1,600 km) initial service and every 2,500 mile (4,000 km) service interval thereafter.

TESTING INTERLOCK

The starter/ignition interlock system is designed to prevent unintended start-up and/or forward motion of the motorcycle. One of three conditions must exist to allow operation of the vehicle:

- Clutch disengaged (lever pulled in - must be done whenever starting motorcycle).
- Transmission in Neutral
- Sidestand retracted

If the motorcycle starts and operates without any of the three conditions being met, see [7.11 STARTER/IGNITION INTERLOCK](#), for troubleshooting procedures.

TESTING SWITCHES

Check the following electric switches for proper operation:

- Left and Right directional signals and dash indicator.
- Neutral indicator Light on dash
- Headlamp low and high beam, high beam flash and high beam indicator light
- Oil Pressure Indicator Light
- Odometer reset switch
- Tail lamp
- Brake lamp with both front and rear brake application
- Speedometer
- Horn
- Ignition stop/run switch
- Electric starter switch

GENERAL

Check stabilizer links and engine mounts for damage and hardware for proper tightness:

- At every 10,000 mile (16,000 km) service interval.

Inspect muffler strap and exhaust system hardware for damage and proper tightness:

- At every 10,000 mile (16,000 km) service interval.

Inspect critical fasteners (listed below) for proper tightness:

- At every 10,000 mile (16,000 km) service interval.

CRITICAL FASTENER TORQUES

Left and Right Handlebar Control Fasteners:

- Left: 25-33 **in-lbs** (2.8-3.7 Nm)
- Right: 12-17 **in-lbs** (1.4-1.9 Nm)

Handlebar Fasteners:

- 10-12 ft-lbs (14-16 Nm)

Brake Banjo Bolts:

- 16-20 ft-lbs (22-27 Nm)

Brake Caliper Mounting Bolts:

- Front: 18-22 ft-lbs (24-30 Nm)
- Rear (Large): 18-22 ft-lbs (24-30 Nm)
- Rear (Small): 14.5-18 ft-lbs (20-24 Nm)
- Caliper Pin: 11-14.5 ft-lbs (15-20 Nm)

Front and Rear Rotor TORX Screws:

- 24-27 ft-lbs (33-37 Nm)

Front and Rear Axle Nuts:

- Front: 38-42 ft-lbs (52-57 Nm)
- Rear: 48-52 ft-lbs (65-71 Nm)

Front Fork Upper Triple Clamp Pinch Bolts:

- (At Sliders): 13-16 ft-lbs (18-22 Nm)
- (At Center Cap): 7-10 ft-lbs (10-14 Nm)

Front Fork Lower Triple Clamp Pinch Bolts:

- 22-29 ft-lbs (30-39 Nm)

Muffler Fasteners (Front and Rear):

- 22-25 ft-lbs (30-34 Nm)

Stabilizer Link Fasteners:

- 30-33 ft-lbs (41-45 Nm)

Engine Mount Fasteners:

- Front Isolator Mounting Bolt: 63-70 ft-lbs (86-95 Nm)
- Rear Engine to Frame Mount: 30-33 ft-lbs (41-45 Nm)

GENERAL

If the motorcycle will not be operated for several months, such as during the winter season, there are several things which should be done to protect parts against corrosion, to preserve the battery and to prevent the buildup of gum and varnish in the carburetor.

This work should be performed by your local Buell dealer or other qualified technician following Service Manual procedures.

WARNING

Gasoline is extremely flammable and highly explosive. Do not store motorcycle having gasoline in tank within the home or garage where open flames, pilot lights, sparks or electric motors are present. Failure to heed this warning could lead to an explosion or fire resulting in death or serious injury.

1. Fill fuel tank and add a gasoline stabilizer. Use one of the commercially available gasoline stabilizers following the manufacturer's instructions. Start and run engine until stabilizer reaches carburetor bowl. Turn engine OFF. Turn fuel supply valve off.
2. Fill the oil reservoir. Pinch off (or remove and plug) the line leading from the oil reservoir bottom to the oil pump feed fitting. This prevents oil from seeping past the check ball into the oil pump and filling the engine flywheel compartment.
3. Remove the spark plug, inject a few squirts of engine oil into the cylinder and crank the engine 5-6 revolutions. Reinstall spark plug.
4. Adjust primary chain. See [1.12 PRIMARY CHAIN](#)
5. Check tire inflation. If the motorcycle will be stored for an extended period of time, securely support the motorcycle under the frame so that all weight is off the tires.
6. See [1.3 BODY PANEL CARE/MAINTENANCE](#). Wash colored surfaces. Apply a light film of oil to exposed unpainted metal surfaces.

WARNING

Do not apply any oil to brake discs or brake pads. Oil on disc pads degrades braking efficiency which could result in an accident, death or serious injury.

7. Remove battery from vehicle. Charge battery until the correct voltage is obtained. Charge the battery every other month if it is stored at temperatures below 60°F (16°C). Charge battery once a month if it is stored at temperatures above 60°F (16°C).

WARNING

Always unplug or turn off battery charger before connecting or disconnecting charger clamps at battery. Connecting or disconnecting clamps with charger on could cause a spark and a possible battery explosion. A battery explosion may rupture the battery case and spray

sulfuric acid onto the surrounding area and personnel, which could result in death or serious injury.

- **Store battery out of reach of children. Battery contains sulfuric acid which can cause severe burns to eyes, skin and clothing.**
8. If motorcycle is to be covered, use a material that will breathe, such as light canvas. Plastic materials that do not breathe promote the formation of condensation.

REMOVAL FROM STORAGE

WARNING

After extended periods of storage and prior to starting vehicle, place transmission in gear, disengage clutch and push vehicle back and forth a few times to ensure proper clutch disengagement. Failure to do so could result in death or serious injury.

1. See [7.16 BATTERY](#) for proper battery care.
2. Remove and inspect the spark plug. Replace if necessary. See [1.16 SPARK PLUG](#).
3. Clean the air cleaner element. See [1.17 AIR CLEANER](#).
4. Start the engine and run until it reaches normal operating temperature. Turn off engine.
5. Check amount of oil in the oil reservoir. Check the transmission lubricant level.
6. Check controls to be sure they are operating properly. Operate the front and rear brakes, throttle, clutch and shifter.
7. Check steering for smoothness by turning the handlebars through the full operating range.

WARNING

Maintain proper tire pressure; including wheel and tire balance. Inspect your tires periodically and replace tires with approved tires only. (See your Buell Dealer.) Improper balance, abnormal tread wear and poor handling could result in death or serious injury.

8. Check tire pressure. Incorrect pressure will result in poor riding characteristics and can affect handling and stability.
9. Check all electrical equipment and switches including the stop lamp, turn signals and horn for proper operation.
10. Check for any fuel, oil or brake fluid leaks.
11. Perform all of the items listed in the PRE-RIDING CHECKLIST in the Owner's Manual.

CAUTION

Turn engine over a few times to be sure there is no oil in the crankcase and that all oil has been pumped back into the oil reservoir. Stop engine and re-check oil level. Failure to do so may result in engine damage.

The following check list can be helpful in locating most operating troubles. Refer to the appropriate sections in this Service Manual for detailed procedures.

ENGINE

Starting Motor Does Not Operate or Does Not Turn Engine Over

1. Engine run switch in OFF position.
2. Ignition switch not on.
3. Discharged battery, loose or corroded connections. (Solenoid chatters.)
4. Starter control relay or solenoid not functioning.
5. Electric starter shaft pinion gear not engaging or over-running clutch slipping.
6. Clutch lever not pulled in.

Engine Turns Over But Does Not Start

1. Fuel tank empty.
2. Fuel valve turned off.
3. Fuel valve or filter clogged.
4. Discharged battery, loose or broken battery terminal connections.
5. Fouled spark plug.
6. Spark plug cable in bad condition and shorting or cable connections loose.
7. Ignition timing badly out of adjustment.
8. Loose wire connection at coil or battery connection or plug between ignition sensor and module.
9. Ignition coil not functioning.
10. Ignition module not functioning.
11. Ignition sensor not functioning.
12. Sticking or damaged valve or valves.
13. Engine flooded with gasoline as a result of over chocking.
14. Engine oil too heavy (winter operation).

Starts Hard

1. Spark plug in bad condition, have improper gap or are partially fouled.
2. Spark plug cable in bad condition and shorting.
3. Battery nearly discharged.
4. Loose wire connection at one of the battery terminals, at coil, or at plug between ignition sensor and module.
5. Carburetor controls not adjusted correctly.
6. Ignition coil not functioning.
7. Engine oil too heavy (winter operation).
8. Ignition not timed properly.
9. Fuel tank filler cap vent plugged, or carburetor fuel line closed off restricting fuel flow.
10. Water or dirt in fuel system and carburetor.
11. Enrichener valve inoperative.

12. Air leak at intake manifold.
13. Valves sticking.

Starts But Runs Irregularly or Misses

1. Spark plug in bad condition or partially fouled.
2. Spark plug cable in bad condition and shorting.
3. Spark plug gap too close or too wide.
4. Ignition coil not functioning.
5. Ignition module not functioning.
6. Ignition sensor not functioning.
7. Battery nearly discharged.
8. Damaged wire or loose connection at battery terminals or coil.
9. Intermittent short circuit due to damaged wire insulation.
10. Water or dirt in fuel system and carburetor or filter.
11. Fuel tank filler cap vent plugged or carburetor float bowl vent closed off.
12. Carburetor controls improperly adjusted.
13. Air leak at intake manifold or air cleaner.
14. Damaged intake or exhaust valve.
15. Weak or broken valve springs.
16. Incorrect valve timing.

Spark Plug Fouls Repeatedly

1. Incorrect spark plug.
2. Piston rings badly worn or broken.
3. Fuel mixture too rich (see CARBURETOR TROUBLESHOOTING).
4. Valve stem seals worn or damaged.
5. Valve guides badly worn.

Pre-Ignition or Detonation (Knocks or Pings)

1. Excessive carbon deposit on piston head or combustion chamber.
2. Incorrect heat range spark plug.
3. Spark plug not firing.
4. Ignition timing advanced.
5. Fuel octane rating too low.
6. Intake manifold vacuum leak.

Overheating

1. Insufficient oil supply, or oil not circulating.
2. Leaking valves.
3. Heavy carbon deposit.
4. Ignition timing retarded.

Valve Train Noise

1. Hydraulic lifter not functioning properly.
2. Bent push rod.

3. Cam, cam gears, or cam bushings worn.
4. Rocker arm binding on shaft.
5. Valve sticking in guide.

Excessive Vibration

1. Upper mounting bracket loose, broken or improperly spaced.
2. Lower mounting bolts loose.
3. Broken frame.
4. Primary chain badly worn or links tight as a result of insufficient lubrication.
5. Wheels not aligned and/or tires worn.
6. Internal engine problem.
7. Engine mount loose, or broken.

ENGINE LUBRICATION SYSTEM

Oil Does Not Return To Oil Reservoir

1. Oil reservoir empty.
2. Return pump gears damaged.
3. Oil feed pump not functioning.
4. Restricted oil lines or fittings.

Engine Uses Too Much Oil or Smokes Excessively

1. Piston rings badly worn or broken.
2. Valve stem seals worn or damaged.
3. Valve guides worn.

Engine Leaks Oil From Cases, Push Rods, Hoses, Etc.

1. Loose parts.
2. Imperfect seal at gaskets, push rod cover, washers, etc. To aid locating leaks, use BLACK LIGHT LEAK DETECTOR (Part No. HD-35457).
3. Restricted oil return line to reservoir.
4. Restricted breather passage(s) to air cleaner.

ELECTRICAL SYSTEM

Alternator Does Not Charge

1. Regulator-rectifier module not functioning.
2. Rectifier not grounded.
3. Engine ground wire loose or broken.
4. Loose or broken wires in charging circuit.
5. Stator not functioning.
6. Rotor not functioning.

Alternator Charge Rate Is Below Normal

1. Regulator-rectifier module not functioning.
2. Stator not functioning.
3. Rotor not functioning.
4. Weak battery.

5. Loose connections.

FUEL

Carburetor Floods

1. Excessive "pumping" of hand throttle grip.
2. Inlet valve sticking.
3. Inlet valve and/or valve seat worn or damaged.
4. Dirt or other foreign matter between valve and its seat.
5. Float misadjusted or filled with fuel.

TRANSMISSION

Shifts Hard

1. Clutch dragging slightly.
2. Shifter forks (inside transmission) damaged.
3. Corners worn off shifter clutch dogs (inside transmission).

Jumps Out of Gear

1. Shifter pawl improperly adjusted.
2. Shifter engaging parts (inside transmission) badly worn and rounded.
3. Shifter forks bent.
4. Damaged gears.

CLUTCH

Slips

1. Clutch controls improperly adjusted.
2. Worn friction plates.

Drags or Does Not Release

1. Clutch controls improperly adjusted.
2. Clutch plates excessively warped.

Chatters

1. Friction or steel plates worn, warped, or dragging.

CHASSIS

Irregular/Inadequate Brake Action

1. Master cylinder low on fluid.
2. Brake line contains air bubbles.
3. Master or wheel cylinder piston worn.
4. Brake pads impregnated with grease or oil.
5. Brake pads badly worn (1/16 in. (1.6 mm) minimum lining thickness).
6. Brake disc badly worn or warped.
7. Brake pads dragging or excessive braking (brake fades due to heat buildup).
8. Insufficient brake pedal or hand lever free play (brake drags).

Handling Irregularities

1. Tires improperly inflated. Check [2.3 TIRE SPECIFICATIONS](#). Do not overinflate.
2. Loose wheel axle nuts. Tighten front nut to 38-42 ft-lbs (51.5-56.94 Nm). Tighten rear nut to 48-52 ft-lbs (65-70 Nm).
3. Excessive wheel hub bearing play.
4. Rear wheel out of alignment with frame and front wheel.
5. Rims and tires out-of-true sideways (tire runout should not be more than 5/64 in. (2.0 mm)).
6. Rims and tires out-of-round or eccentric with hub (tire runout should not be more than 3/32 in. (2.4 mm)).
7. Irregular or peaked front tire tread wear.
8. Tire and wheel unbalanced.
9. Steering head bearings improperly adjusted. Correct adjustment, and replace pitted or worn bearings and races. See [2.19 FORK STEM AND BRACKET ASSEMBLY](#).
10. Shock absorber not functioning normally.
11. Heavy front end loading. Non-standard equipment on the front end (such as heavy radio receivers, extra lighting equipment, or luggage) tends to cause unstable handling.

Table Of Contents

SUBJECT	PAGE NO.
2.1 Specifications	2-1
2.2 Torque Values	2-2
2.3 Tire Specifications	2-5
2.4 Vehicle Identification Number	2-6
2.5 Wheels	2-7
2.6 Front Wheel	2-9
2.7 Rear Wheel	2-11
2.8 Sealed Wheel Bearings	2-14
2.9 Checking Cast Rim Runout	2-16
2.10 Tires	2-17
2.11 Front Brake Master Cylinder	2-20
2.12 Front Brake Caliper	2-24
2.13 Front Brake Line	2-27
2.14 Rear Brake Master Cylinder	2-28
2.15 Rear Brake Caliper	2-31
2.16 Rear Shock Absorber	2-34
2.17 Throttle Control	2-35
2.18 Front Fork	2-37
2.19 Fork Stem And Bracket Assembly	2-50
2.20 Swingarm	2-52
2.21 Exhaust System	2-53
2.22 Footpeg Support Bracket	2-55
2.23 Sprocket Cover	2-56
2.24 Fenders	2-57
2.25 Lower Belt Guard	2-58
2.26 Tail Section And Rear Frame Assembly	2-59
2.27 Windscreen	2-61
2.28 Instrument Panel	2-62
2.29 Seat	2-63
2.30 Side Stand	2-64
2.31 Handlebars	2-65
2.32 Front And Rear Isolators	2-66

DIMENSIONS	IN.	MM
Wheel Base	55.30	1404
Seat Height - Low Seat	25.50	648
High Seat	27.50	698
Road Clearance	5.10	129.5
Trail	3.4	86
Rake	25°	

WEIGHT-U.S. MODELS	LBS.	KG
Wet Weight	380	172
GVWR	780	353
GAWR Front	280	127
GAWR Rear	500	226
Load Capacity	400	181

NOTE

See information decal on frame steering head for Gross Vehicle Weight Rating (GVWR) (maximum allowable loaded vehicle weight) and corresponding Gross Axle Weight Ratings (GAWR).

CAPACITIES	U.S.	Metric
Fuel Tank:		
Total (including reserve)	2.8 gallons	10.60 liters
Reserve	0.55 gallons	2.08 liters
Oil Tank (with filter)	2.0 quarts	1.89 liters
Transmission/Primary	32.0 ounces	946.35 ml
Front Fork (each-wet capacity)	9.2 ounces	272.08 ml

 **WARNING**

Do not inflate any tire beyond its maximum inflation pressure as specified on tire sidewall. Overinflation may lead to premature tire failure which could result in death or serious injury.

TIRE AND POSITION	SOLO RIDING	LOADED TO GVWR
Front Dunlop 100/80 16 50s K330	28 PSI (193 kPa)	32 PSI (220 kPa)
Rear Dunlop 120/80 16 60s K330	30 PSI (207 kPa)	36 PSI (248 kPa)

IGNITION SYSTEM		
Spark Plug	10R12	
Size	12 mm	
Gap	0.038-0.043 in.	0.97-1.09 mm
Torque	11-18 ft-lbs	15-24.4 Nm

TRANSMISSION GEAR RATIOS	FINAL*	OVERALL**
First (low) Gear	2.69	12.74
Second Gear	1.85	8.77
Third Gear	1.43	6.79
Fourth Gear	1.18	5.60
Fifth (high) Gear	1.00	4.74

*Final gear ratios indicate number of mainshaft revolutions required to drive output sprocket one revolution.

**Overall gear ratios indicate number of engine revolutions required to drive rear wheel one revolution.

SPROCKET TEETH	
Engine	35
Clutch	56
Transmission	27
Rear Wheel	80

ENGINE		
Number of Cylinders	1	
Type	4-Cycle, Air cooled, four stroke	
Bore	3.5 in.	88.9 mm
Stroke	3.125 in.	79.375 mm
Engine Displacement	30 cu. in.	492 cc
Compression Ratio	9.2:1	
Horsepower @ RPM	30 @ 6500	
Torque ft-lbs @ RPM	27 @ 3200	
Valve Train	OHV, two valves	
Valve Adjustment	Hydraulic, self-adjusting lifters	
Fuel Delivery	40mm Keihin CV carburetor	

Gasoline

Use a good quality unleaded gasoline which is **87 pump octane** or higher (R+M)/2. Octane rating is usually found on the pump.

TORQUE VALUES

ITEM	TORQUE		NOTES
Brake Bleeder Valve	3-5 ft-lbs	4.1-6.8 Nm	Metric, pages 2-22, 2-30, 2-34, 2-37.
Brake Rotor Screws, TORX	24-27 ft-lb	32.5-36.6 Nm	Tighten in criss-cross pattern, pages 2- 10, 2-12
Clutch Lever Screw	50-60 in-lbs	5.6-6.8 Nm	Page 2- 69
Footpeg Support Mounting Bracket Bolts	25-30 ft-lbs	34-41 Nm	Page 2- 59
Frame-to-Isolator Bolts	30-33 ft-lbs	40.7-44.7 Nm	Apply several drops of LOCTITE® thread locker 272 (red) to last few threads, page 2- 71
Front Axle Nut	38-42 ft-lbs	51.5-56.9 Nm	Apply several drops of LOCTITE® thread locker 243 (blue) to last few threads. Metric, page 2- 10
Front Axle Pinch Screw	13-16 ft-lbs	17.6-21.7 Nm	Metric, page 2- 10
Front Brake Caliper Mounting Bolts	18-22 ft-bs	24.4-29.8Nm	Apply several drops of LOCTITE® thread locker 272 (red) to last few threads, page 2- 24
Front Brake Caliper Pad Hanger Pin	11-14.5 ft-lbs	14.7-19.6 Nm	Metric, page 2- 24
Front Brake Hand Lever Nut	44-62 in-lbs	5.0-7.0 Nm	Metric, page 2- 24
Front Brake Hand Lever Pivot Bolt	4-13 in-lbs	0.5-1.5 Nm	LOCTITE ANTI-SEIZE, Page 2- 24
Front Brake Line Clamp Screw	3-5 ft-lbs	4.1-5 Nm	Page 2- 29
Front Brake Rotor Screws, TORX	24-27 ft-lbs	32.5-36.6 Nm	Tighten in criss-cross pattern. Apply several drops of LOCTITE® thread locker 272 (red) to last few threads, page 2- 10
Front Brake Switch Screw	7-13 in-lbs	0.8-1.5 Nm	Page 2- 24
Front Fender Mounting Screws	12-14 in-lbs	1.3-1.6 Nm	Apply several drops of LOCTITE® thread locker 243 (blue) to last few threads. Page 2- 61
Front Muffler Bolts	22-25 ft lbs	30-34 Nm	Page 2- 58
Front Sprocket Cover Bolts	30-36 in-lbs	3.4-4.1 Nm	Apply several drops of LOCTITE® thread locker 243 (blue) to last few threads. Page 2- 60
Front Tie Bar Bolt	30-33 ft-lbs	40.7-44.7 Nm	Page 2- 70
Handlebar Left Housing Screws	19-23 in-lbs	2-3 Nm	Page 2- 69
Handlebar Right Housing Screws	19-23 in-lbs	2-3 Nm	Page 2- 69

ITEM	TORQUE		NOTES
Handlebar Riser Bolts	10-12 ft-lbs	14-16 Nm	Page 2- 69
Instrument Panel Screws	30-36 in-lbs	3-4 Nm	Apply several drops of LOCTITE® thread locker 243 (blue) to last few threads, metric, Page 2- 66.
Lower Belt Guard	30-36 in-lbs	3.4-4.1 Nm	Page 2- 62
Lower and Upper Header Nuts	6-8 ft-lbs	8.1-10.8 Nm	Tighten Lower Nut First, page 2- 58
Main Isolator Bolt, Mount to Motor	63-70 ft-lbs	(85-95 Nm)	Page 2- 70
Master Cylinder Cover Screws	9-13 in-lbs	1.0-1.5 Nm	Page 2-25
Outboard Isolator Bolts	30-33 ft-lbs	40.7-44.7 Nm	Page 2- 70
Pedal Bolt	6-8 ft-lbs	8-11 Nm	Page 2-60
Rear Axle Nut	48-52 ft-lbs	65.1-70.5 Nm	Page 2-13
Rear Brake Caliper Mounting Screw, Large	18-22 ft-lbs	24.4-29.8 Nm	Metric, page 2- 34
Rear Brake Caliper Mounting Screw, Small	14.5-18 ft-lbs	19.6-24.4 Nm	Metric, page 2- 34
Rear Brake Caliper Pad Hanger Pin	11-14.5 ft-lbs	14.7-19.6 Nm	Metric, page 2- 34
Rear Brake Reservoir Mounting Screw	12-15 in-lbs	1.4-1.7 Nm	Page 2- 31
Rear Fender Mounting Screws	30-36 in-lbs	3.4-4.1 Nm	Page 2- 61
Rear Isolator-to Engine Bolts	23-27 ft-lbs	31-37 Nm	Apply several drops of LOCTITE® thread locker 243 (blue) to last few threads, Page 2- 71
Rear Master Cylinder Mounting Screws	8-10 ft-lbs	10.8-13.6 Nm	Apply several drops of LOCTITE® thread locker 243 (blue) to last few threads, metric, page 2- 31
Rear Muffler Strap Bolts	22-25 ft lbs	30-34 Nm	Page 2- 58
Rear Shock Bottom Bolt	35-40 ft-lbs	47-54 Nm	Page 2-38
Rear Shock Top Bolt	35-40 ft-lbs	47-54 Nm	Page 2- 38
Rear Drive Sprocket Bolts	28-31 ft-lbs	38-42 Nm	Page 2- 12. Apply several drops of LOCTITE® thread locker 272 (red) to last few threads. Discard screws and hardened washers after removal and replace with new.
Steering Head Cap Nut	28-32 ft-lbs	38-43.4 Nm	Page 2- 55. Tighten to 48-52 (65-71 Nm) to seat bearing when adjusting, then loosen and re-tighten to 28-32 ft-lbs (38-43 Nm). Apply LOCTITE THREAD-LOCKER 243 (Blue) to last few threads of fork stem.

ITEM	TORQUE		NOTES
Steering Head Cap Nut Pinch Screw	7-10 ft-lbs	10-14 Nm	Pages 2- 52, 2-55
Steering Head Lower Triple Tree Clamp Screws	22-29 ft-lbs	30-39 Nm	LOCTITE ANTI-SEIZE, Pages 2- 52, 2-55
Steering Head Upper Triple Tree Clamp Screws (at sliders), Allen	13-16 ft-lbs	18-22 Nm	LOCTITE ANTI-SEIZE, Pages 2-52, 2- 55
Swingarm Bolt	24-26 ft-lbs	32.5-35.2 Nm	Apply anti-seize to bolt and install, page 2- 56
Swingarm Pinch Bolt	18-20 ft-lbs	24.4-27.1 Nm	Apply several drops of LOCTITE® thread locker 243 (blue) to last few threads, page 2- 56
Switchgear Housing Screws, Right Side	12-17 in-lbs	1.4-1.9 Nm	Metric, page 2- 39
Valve Stem Nut	42-44 in-lbs	4.7-5.0 Nm	Page 2- 18
Windscreen Screws	9-11 in-lbs	1 Nm	Page 2- 65

GENERAL

WARNING

Tires must be correctly matched to wheel rims. Only the tires listed in the fitment table below can be used for replacement. Mismatching tires and rims can cause damage to the tire bead during mounting. Using tires other than those specified can adversely affect motorcycle handling which could result in death or serious injury.

Tire sizes are molded on the sidewall. Rim size and contour are marked on the rim's exterior surface.

Example: **MT 2.5 x 16.0 DOT**

- **MT** designates the rim contour.
- **2.5** is the width of the bead seat measured in inches.
- **16.0** is the normal diameter of the rim in inches, measured at the bead seat diameter.
- **DOT** means that the rim meets Department of Transportation Federal Motor Vehicle Safety Standards.

See the table below.

Table 2-1. Tire Fitment-Tubeless Cast Wheels

WHEEL SIZE & POSITION	CONTOUR & RIM SIZE	RIM VALVE HOLE DIAMETER	DUNLOP RADIAL TIRE SIZE
16 in. – Front	MT 2.5 x 16.0 DOT	0.33 in. (8.38 mm)	100/80 16 K330
16 in. – Rear	MT 2.75 x 16.0 DOT	0.33 in. (8.38 mm)	120/80 16 K330

GENERAL

See Figure 2-1. Each vehicle has a 17-digit serial or Vehicle Identification Number (V.I.N.) stamped on the steering head. A Motor Identification Number is stamped on the left side crankcase near the front of the engine.

NOTE

Always give the full 17-digit Vehicle Identification Number when ordering parts or making inquiries about your Buell motorcycle.

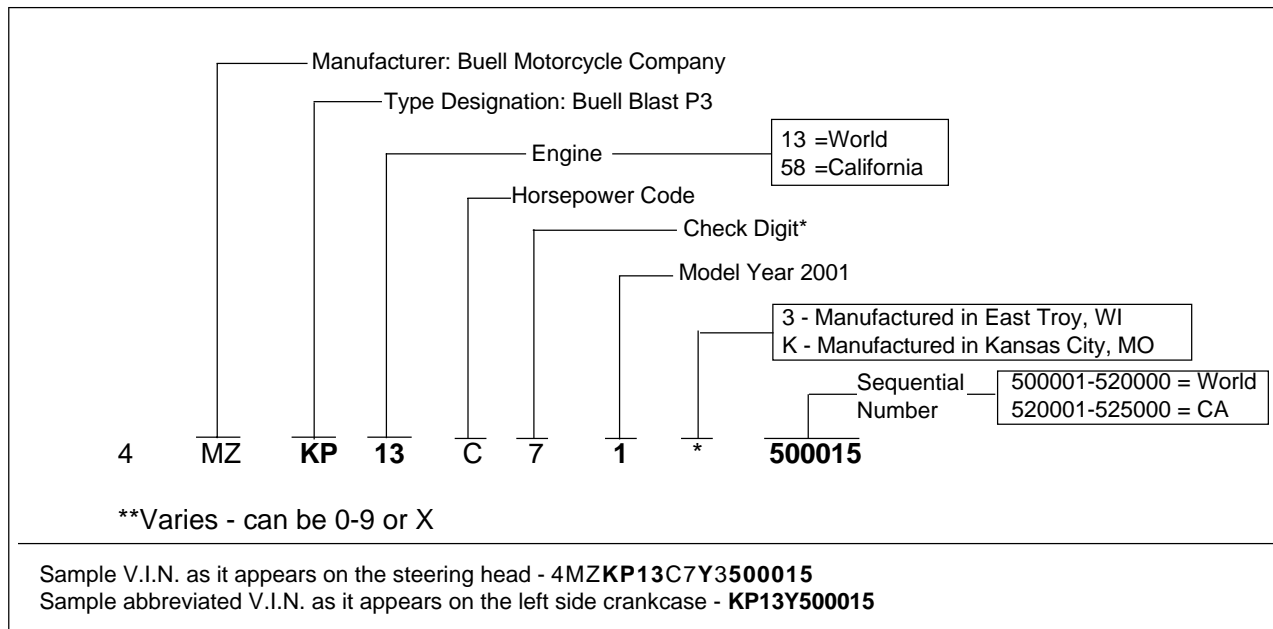

Figure 2-1. Vehicle Identification Numbers (V.I.N.)

GENERAL

Good handling and maximum tire mileage are directly related to the care of wheels and tires. Regularly inspect wheels and tires for damage and wear. If handling problems occur, see [Table 2-2](#).

Keep tires inflated to the recommended air pressure. Always balance the wheel after replacing a tire.

WARNING

Do not inflate any tire beyond its maximum inflation pressure as specified on tire sidewall. Overinflation may lead to premature tire failure which could result in death or serious injury.

TROUBLESHOOTING

See [Figure 2-2](#). Check tire inflation pressure at least once each week. At the same time, inspect tire tread for punctures, cuts, breaks and other damage. Repeat the inspection before long trips.

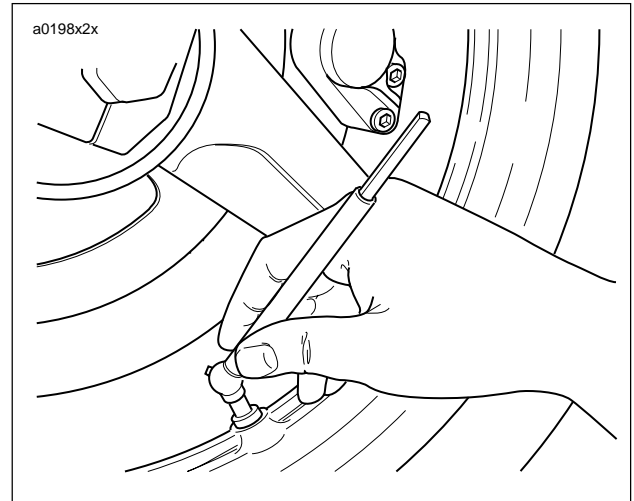

Figure 2-2. Checking Tire Inflation Pressure

Table 2-2. Wheel Service

CHECK FOR	REMEDY
Loose axle nuts.	Apply LOCTITE THREADLOCKER 243 (Blue) and tighten front axle nut (metric) to 38-42 ft-lbs (51.5-56.9 Nm). Tighten rear axle nut (metric) to 48-52 ft-lbs (65.1-70.5 Nm).
Excessive side-play or radial (up-and-down) play in wheel hubs.	Replace wheel hub bearings.
Alignment of rear wheel in frame or with front wheel.	Repair swingarm as described under 2.20 SWINGARM .
Rims and tires out-of-true sideways; should not be more than 0.080 in. (2.03 mm).	Replace rims. See 2.10 TIRES .
Rims and tires out-of-round or eccentric with hub; should not be more than 0.090 in. (2.29 mm).	Replace rims. See 2.10 TIRES .
Irregular or peaked front tire wear.	Replace as described under 2.6 FRONT WHEEL or 2.10 TIRES .
Correct tire inflation.	Inflate tires to correct pressure. See 2.3 TIRE SPECIFICATIONS .
Correct tire and wheel balance.	Static balance may be satisfactory if dynamic balancing facilities are not available. However, dynamic balancing is strongly recommended.
Steering head bearings.	Correct adjustment and replace pitted or worn bearings. See 2.19 FORK STEM AND BRACKET ASSEMBLY .
Damper tubes.	Check for leaks. See 2.18 FRONT FORK .
Shock absorber.	Check damping action and mounts. See 2.16 REAR SHOCK ABSORBER .
Swingarm bearings.	Check for looseness. See 2.20 SWINGARM .

⚠ WARNING

Use the following guidelines when installing a new tire or repairing a flat. Failure to comply with the guidelines below could result in death or serious injury.

1. Always locate and eliminate the cause of the original tire failure.
2. Do not patch or vulcanize a tire casing. These procedures weaken the casing and increase the risk of a blowout.
3. Do not use tires other than those specified.
4. Tires and wheels are critical items. Since the servicing of these components requires special tools and skills, Buell recommends that you see your dealer for these services.

⚠ WARNING

Buell recommends replacement of any tire punctured or damaged. In some cases small punctures in the tread area may be repaired from within the demounted tire by your Buell dealer. Speed should not exceed 50 mph (80 km/h) for the first 24 hours after repair and the repaired tire should NEVER be used over 80 mph (128 km/h).

In emergency situations, if a temporary repair is made, ride slowly with as light of a load as possible until the tire is permanently repaired or replaced.

Failure to follow this warning could result in death or serious injury.

⚠ WARNING

Excessively worn tires adversely affect motorcycle traction, steering and handling, which could result in death or serious injury.

At regular intervals of 5000 miles (8000 km) or whenever handling irregularities are noted, perform the recommended service checks. See [Table 2-2](#).

If tires must be replaced, same as original equipment tires must be used. Other tires may not fit correctly and may be hazardous to use.

REMOVAL

1. Raise front wheel off floor.
2. Inspect wheel bearing end play and service bearings if necessary. See 2.8 SEALED WHEEL BEARINGS.
3. Remove brake pads.
 - a. See Figure 2-3. Remove pin plug (4).
 - b. See Figure 2-4. Remove pad hanger pin (metric).
 - c. Remove brake pads from caliper.
4. See Figure 2-3. Detach caliper from mounts.
 - a. Remove lower mounting screw (5).
 - b. Remove upper mounting screw (5) and brakeline wireform (7) while supporting caliper above brake rotor.
 - c. Remove caliper by tilting away from wheel and then pulling away from rotor.

NOTE

Do not operate front brake lever with front wheel removed or caliper pistons may be forced out. Reseating pistons requires caliper disassembly.

5. See Figure 2-5. Insert screwdriver/rod through axle hole (1). Loosen front axle nut (4).
6. Loosen pinch screw (2).
7. Remove front axle nut, spacer and washer. Pull front axle out of wheel hub while supporting front wheel.

DISASSEMBLY

1. See Figure 2-6. Remove five bolts (10) and washers (11) to detach front brake rotor (12) from wheel hub. Discard washers.
2. Remove tire. See 2.10 TIRES.

CLEANING AND INSPECTION

1. Thoroughly clean all parts in solvent.
2. Inspect all parts for damage or excessive wear.

⚠ WARNING

Always replace brake pads in complete sets for correct brake operation. Never replace just one brake pad. Failure to install brake pads as a set could result in death or serious injury.

3. Inspect brake rotor and pads.

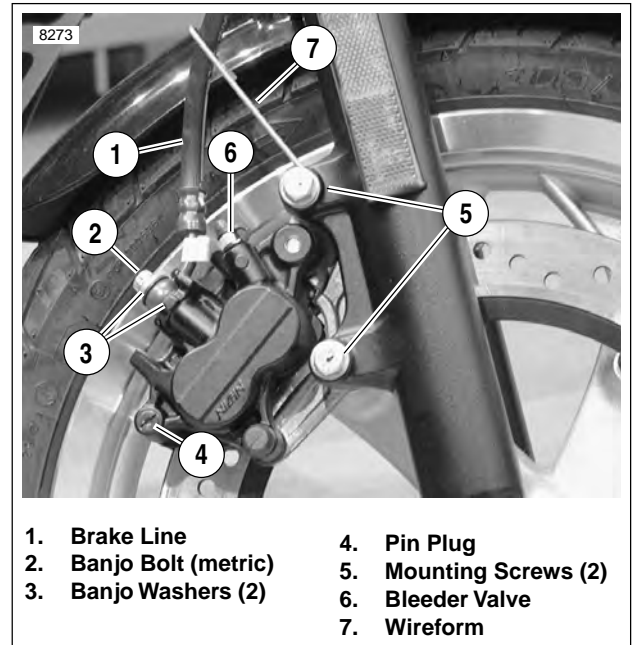

Figure 2-3. Front Brake Caliper

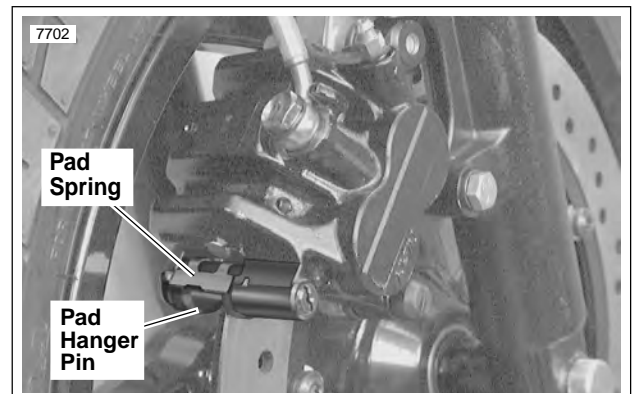

Figure 2-4. Pad Spring

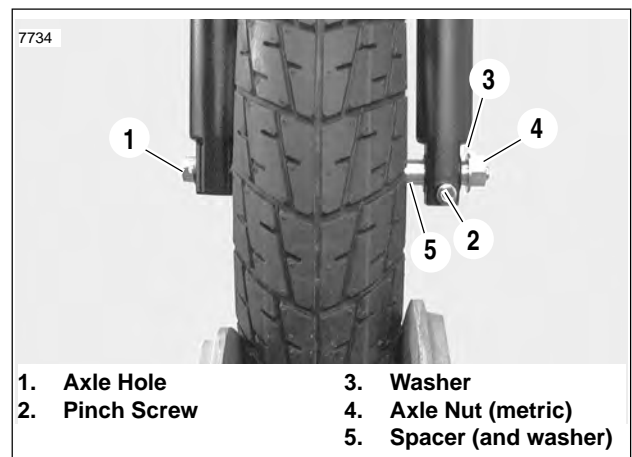

Figure 2-5. Front Wheel Mounting

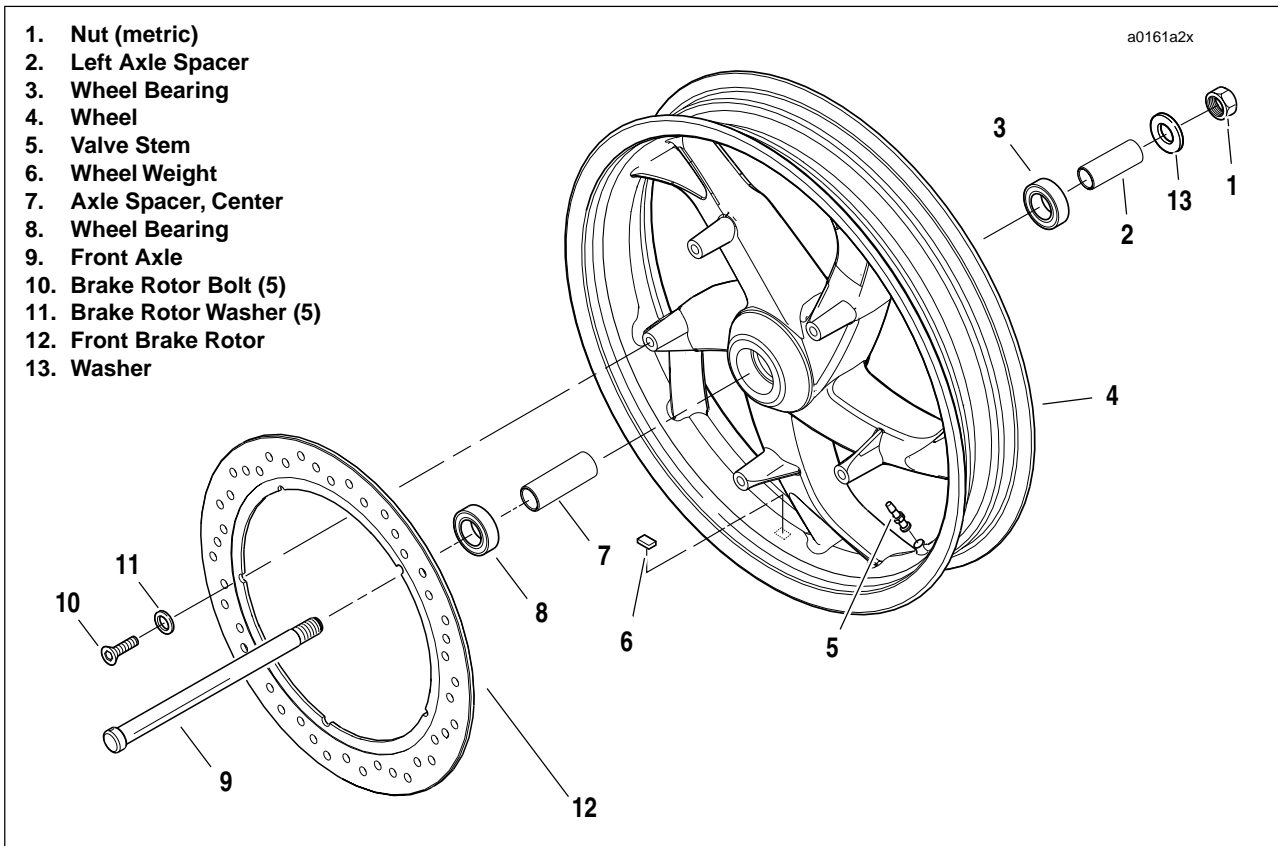

Figure 2-6. Front Wheel Assembly

ASSEMBLY

WARNING

Do not allow brake fluid, bearing grease, or other lubricants to contact brake rotor or brake pads or reduced braking ability may occur which could result in death or serious injury.

1. See [Figure 2-6](#). Install front brake rotor (12) on right side of wheel.
 - a. Verify that the front brake rotor is thoroughly clean.
 - b. Apply LOCTITE THREADLOCKER 272 (red) to threads of each of the five T40 TORX screws (10).

NOTE

Do NOT reuse brake rotor mounting washers (11). Always use new washers (P/N CB0004.T) when assembling wheel.

- c. Install rotor (12) on wheel hub. Tighten TORX screws (10) with NEW washers (11) in criss-cross pattern to 24-27 ft-lbs (32.5-36.6 Nm).
2. Install tire, if removed. See [2.10 TIRES](#).
3. Verify that wheel and tire are true. See [2.9 CHECKING CAST RIM RUNOUT](#).
4. Balance tire. See [2.10 TIRES, Adjustment](#).

INSTALLATION

1. Install front axle.
 - a. Position wheel between forks with brake rotor on gearcase side of motor.
 - b. With pinch screw (metric) loose, insert threaded end of axle through right side fork.
 - c. Push axle through fork and wheel hub until axle begins to emerge from left side of hub.
 - d. Install axle spacer (2) and washer (13).
2. Compress the front suspension to make sure it is free and not binding.
3. See [Figure 2-6](#). Install axle nut.
 - a. Apply LOCTITE THREADLOCKER 243 (blue) to axle threads.
 - b. Install axle nut (1) (metric) over threaded end of axle.
 - c. Insert screwdriver or steel rod through hole in axle.
 - d. While holding axle stationary, tighten axle nut (1) (metric) to 38-42 ft-lbs (51.5-56.9 Nm).
4. Tighten the front axle pinch screw to 13-16 ft-lbs (17.6-21.7 Nm).
5. Install front brake caliper. See [2.12 FRONT BRAKE CALIPER](#).

REMOVAL

1. Raise rear wheel off floor using REAR WHEEL SUPPORT STAND (Part No. B-41174).
2. Inspect wheel bearing end play and service bearings if necessary. See 2.8 SEALED WHEEL BEARINGS.

NOTE

Do not operate rear brake pedal with rear wheel removed or caliper piston may be forced out. Reseating piston requires caliper disassembly.

3. See Figure 2-7. Place rod or screwdriver through axle hole. Loosen rear axle nut (1) (metric).
4. Remove nut, lockwasher, and flat washer.
5. Pull axle out. Remove right side spacer.
6. Slide carrier with caliper off rotor.
7. Remove left side spacer.
8. Move wheel forward and slide belt off.

DISASSEMBLY

1. See Figure 2-8. Remove and discard five sprocket bolts (6) from sprocket cover.
2. Remove sprocket cover (7) from sprocket.
3. Remove and discard hardened washers from sprocket.
4. Remove sprocket from rear wheel.
5. Remove five T40 TORX screws and brake rotor from rear wheel.

CLEANING AND INSPECTION

1. Thoroughly clean all parts in solvent.
2. Inspect all parts for damage or excessive wear.
3. Inspect brake rotor.
 - a. Measure rotor thickness. **Replace if less than 4.5 mm.** See 2.15 REAR BRAKE CALIPER.
 - b. Check rotor surface. Replace if warped or badly scored.
4. Inspect tire. See 2.10 TIRES.

ASSEMBLY

⚠ WARNING

Do not allow brake fluid, bearing grease or other lubricants to contact brake rotor or brake pads or reduced braking ability may occur which could result in death or serious injury.

1. Lay wheel on clean work area with rotor side down.
2. Position sprocket on rim with holes in sprocket and rim aligned.

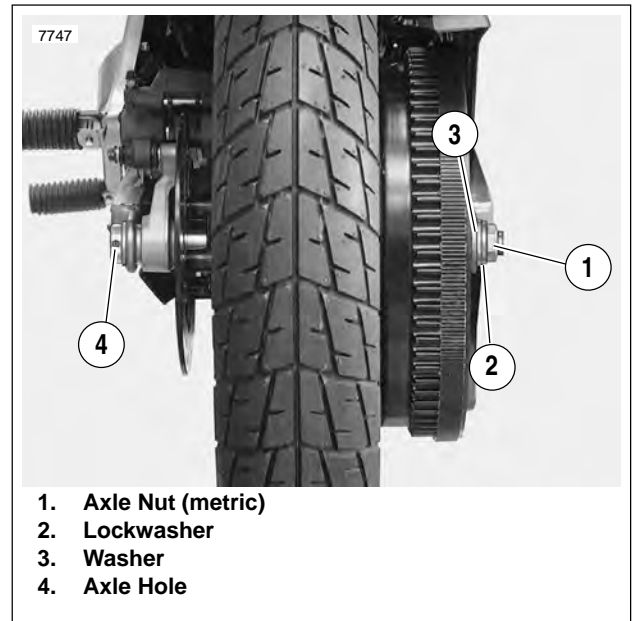

Figure 2-7. Rear Wheel Mounting

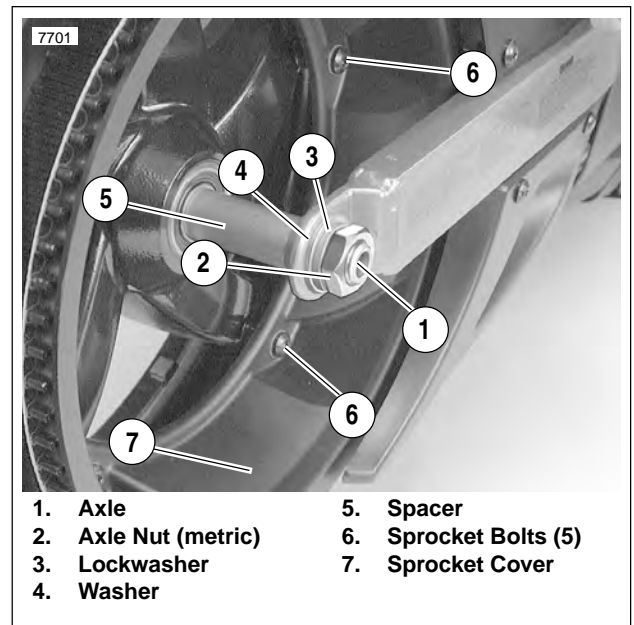

Figure 2-8. Rear Axle, Right Side

⚠ WARNING

Use only new P/N BA0511.2Z hardened washers between sprocket cover and sprocket. Failure to use hardened washers could cause sprocket to fail. Drive sprocket failure could lead to loss of control of vehicle which could result in death or serious injury.

3. Place **new** hardened washers on sprocket.
4. Position sprocket cover over washers and install to sprocket with five **new** sprocket bolts. Tighten sprocket bolts to 28-31 ft-lbs (38-42 Nm).
5. See [Figure 2-9](#). Install brake rotor (9) to wheel.
 - a. Verify that the brake rotor is thoroughly clean.
 - b. Apply **LOCTITE THREADLOCKER 272** (red) to threads of each of the five T40 TORX screws (8).
 - c. Install rotor (9) on wheel hub. Tighten TORX screws in criss-cross pattern to 24-27 ft-lbs (32.5-36.6 Nm).

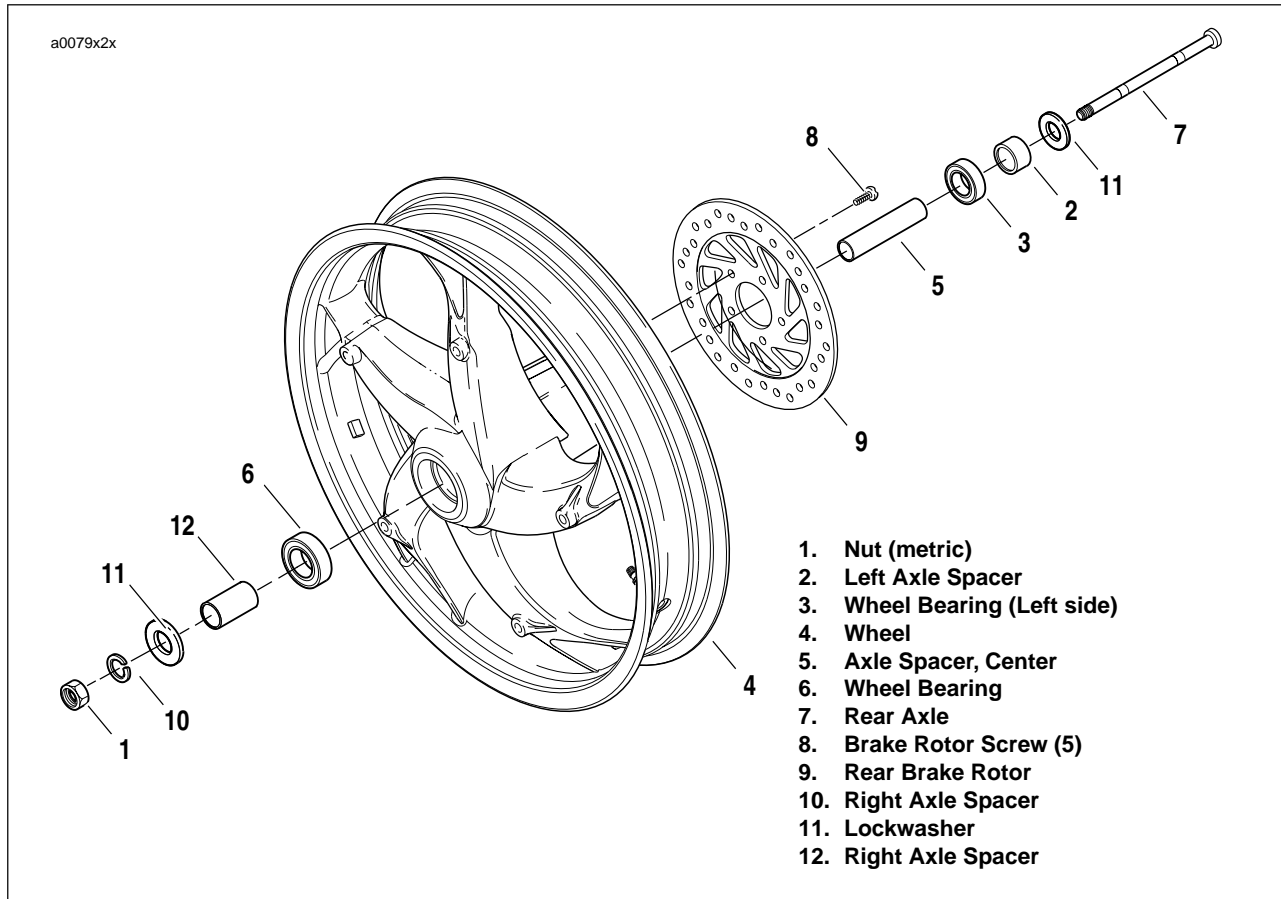

Figure 2-9. Rear Wheel Assembly

INSTALLATION

1. Place wheel centrally in the swingarm. Slide wheel far enough forward to slip belt over sprocket and rest belt on sprocket inboard of the teeth.

NOTE

Do not place belt on sprocket teeth at this time. Alignment of parts will be difficult. Resting belt next to teeth allows slack for easier alignment of wheel assembly.

2. See [Figure 2-10](#). Hold left side spacer in place and slide caliper and carrier over rotor.
3. Slide axle through washer, swing arm, carrier, left side spacer and wheel assembly.
 - a. See [Figure 2-11](#). Hold right side spacer in place.
 - b. Insert axle through right side spacer and swingarm.
 - c. Install flat washer, lockwasher and axle nut.
4. Place screwdriver or rod through axle hole and torque rear axle nut to 48-52 ft-lbs (65.1-70.5 Nm).
5. Slide belt on sprocket teeth by rotating wheel to “walk” belt onto teeth.
6. Lower motorcycle rear wheel.

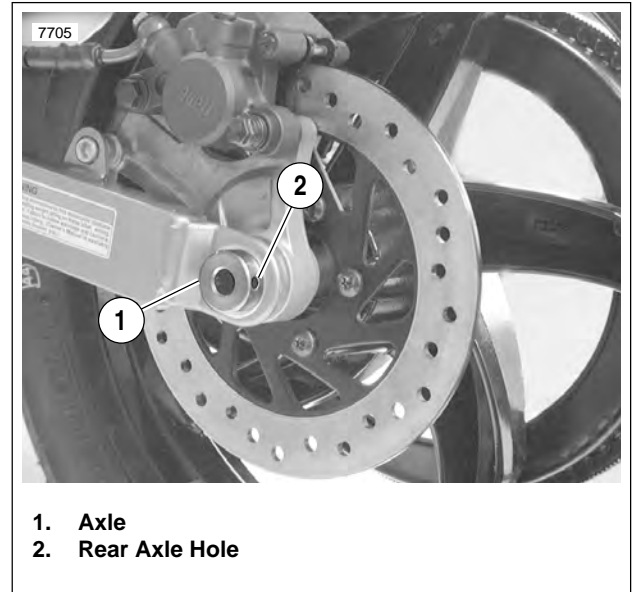

Figure 2-10. Rear Axle, Left Side

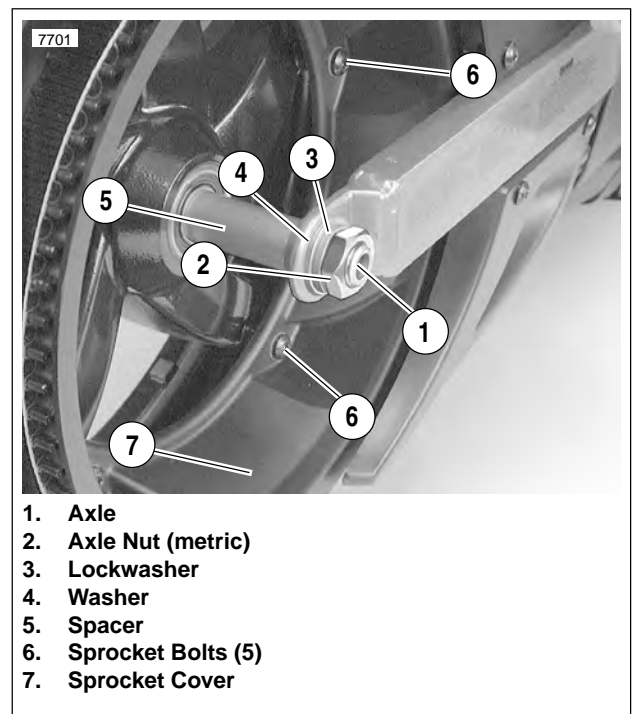

Figure 2-11. Rear Axle, Right Side

INSPECTION

1. Block motorcycle underneath frame so wheel is raised off the ground.
2. See [Figure 2-12](#). Mount a magnetic base dial indicator to the brake disc with the dial's contact point on the end of the axle.
3. Turn the wheel through several rotations, then move the wheel side to side to check for lateral end play.
 - a. If the end play is less than the service wear limit of 0.002 in. (0.051 mm), bearing passes inspection.
 - b. If the end play exceeds service wear limit or feels rough, remove wheel and replace both wheel bearings.

REMOVAL

PART NO.	SPECIALTY TOOL
B-43933	Wheel bearing installer/remover

1. Remove wheel from motorcycle.
2. See [Figure 2-13](#). Obtain WHEEL BEARING INSTALLER/REMOVER (Part No. HD-44060) and assemble.
 - a. Sparingly apply graphite lubricant to threads of forcing screw (1) to prolong service life and ensure smooth operation.
 - b. Install nut (2), washer (3) and Nice bearing (4) on screw. Insert assembly through hole in bridge (5).
 - c. Drop ball bearing inside collet (6). Fasten collet and ball bearing to forcing screw (1).
3. Hold end of forcing screw (1) and turn collet (6) to expand edges of collet.
4. See [Figure 2-14](#). When expanded collet has gripped bearing edges, hold end of forcing screw (1) and turn the nut (2) to remove bearing from wheel.
5. Remove spacer from inside wheel hub.
6. Repeat procedure for opposite side bearing. Discard all bearings upon removal.

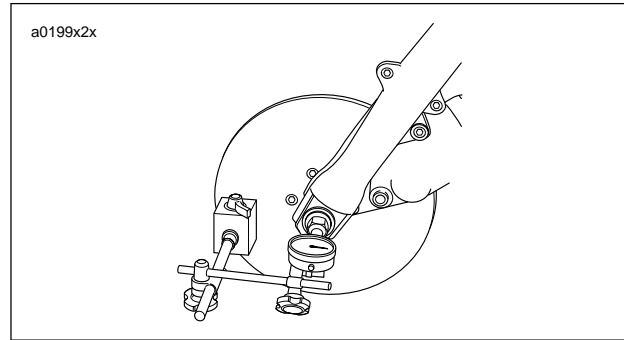

Figure 2-12. Wheel Bearing Inspection (Front Wheel Shown)

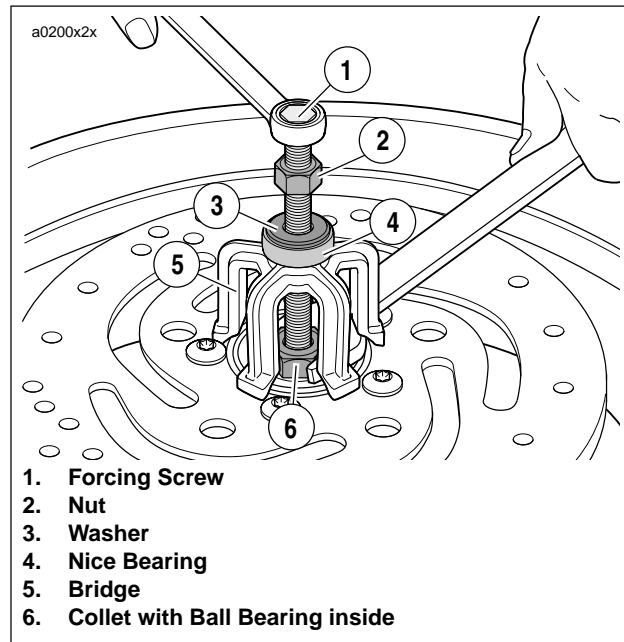

Figure 2-13. Removal Tool

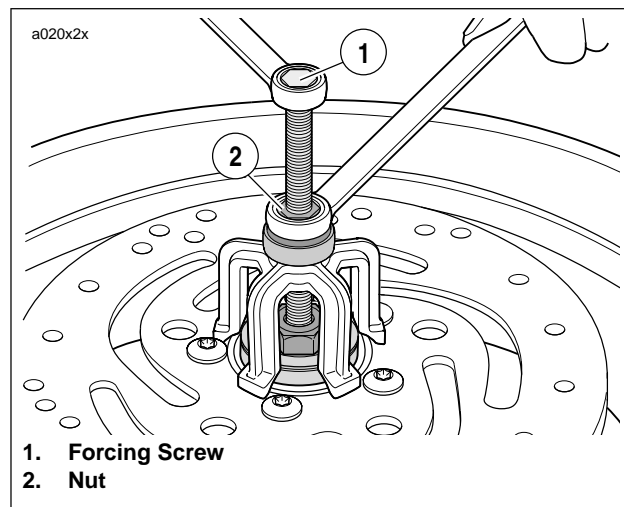

Figure 2-14. Remove Bearing

INSTALLATION

PART NO.	SPECIALTY TOOL
B-43933	See Figure 2-17. Wheel bearing installer/remover.

NOTE

Always install first bearing on primary brake disc side. If front wheel has two brake discs, install bearing on the left side first.

1. Obtain WHEEL BEARING INSTALLER/REMOVER (Part No. B-43933) and assemble.
 - a. Sparingly apply graphite lubricant to threads of threaded rod to prolong service life and ensure smooth operation.
 - b. See Figure 2-15. Place threaded rod through support plate. Insert assembly through wheel.
 - c. See Figure 2-16. Place the **new** bearing (6) on rod (1) with lettered side outward.
 - d. Install pilot (5), Nice bearing (4), washer (3) and nut (2) over rod.
2. Hold hex end of threaded rod (1) and turn nut (2) to install bearing (6). Bearing will be fully seated when nut can no longer be turned. Remove tool.
3. Install spacer sleeve inside wheel hub.
4. Reverse tool and install opposite side bearing.

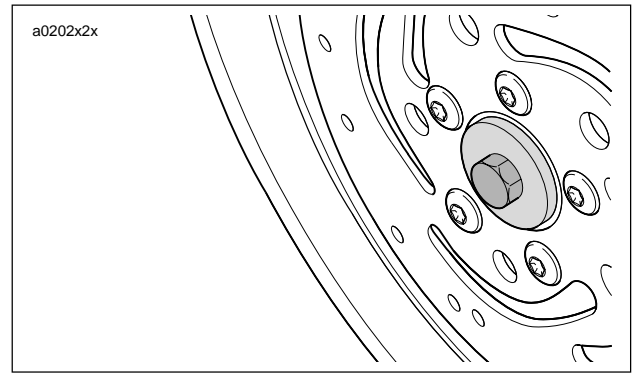
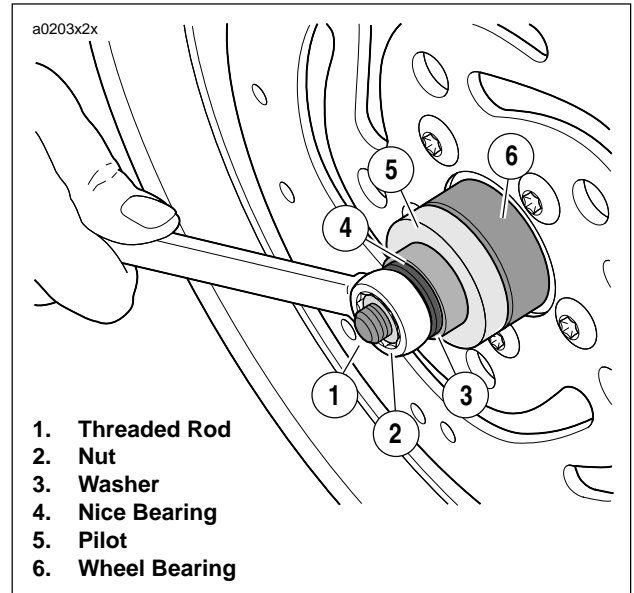

Figure 2-15. Installation Tool Support Plate



1. Threaded Rod
2. Nut
3. Washer
4. Nice Bearing
5. Pilot
6. Wheel Bearing

Figure 2-16. Installing Bearing

Parts 1-7 common to removal/installation.
Parts 8-9 used for removal only.
Parts 10-13 used for installation only.

NO.	DESCRIPTION	PART NO.
1	Bridge	HD-44060-5
2	Steel Ball	12547
3	Forcing Screw	HD-44060-4
4	Nut	10210
5	Washer	12004
6	Nice Bearing	RS25100-200
7	Lubricant	J-23444A
8	Collet, 3/4 in.	B-43993-3
9	Collet, 1.0 in.	B-43993-7
10	Pilot, 1.0 in.	B-43993-8
11	Pilot, 3/4 in.	B-43993-6
12	Support Plate	B-43993-1
13	Threaded Rod	280856

Figure 2-17. Wheel Bearing Remover/Installer (Part No. B-43933)

GENERAL

Check wheels for lateral and radial runout before installing a new tire.

Rim Lateral Runout

1. See Figure 2-18. Install truing arbor in wheel hub and place wheel in WHEEL TRUING AND BALANCING STAND (Part No. HD-99500-80).
2. Tighten arbor nuts so hub will turn on its bearings.
3. Check rim lateral runout by placing a gauge rod or dial indicator near the rim bead. Replace wheel if lateral runout exceeds specification shown in Table 2-3.

Rim Radial Runout

1. See Figure 2-19. Install truing arbor in wheel hub and place wheel in WHEEL TRUING AND BALANCING STAND (Part No. HD-99500-80).
2. Tighten arbor nuts so hub will turn on its bearings.
3. Check radial runout as shown. Replace wheel if runout exceeds specification shown in Table 2-3.

Table 2-3. Wheel Runout

WHEEL TYPE	MAXIMUM LATERAL RUNOUT	MAXIMUM RADIAL RUNOUT
Cast	0.040 in. (1.02 mm)	0.030 in. (0.76 mm)

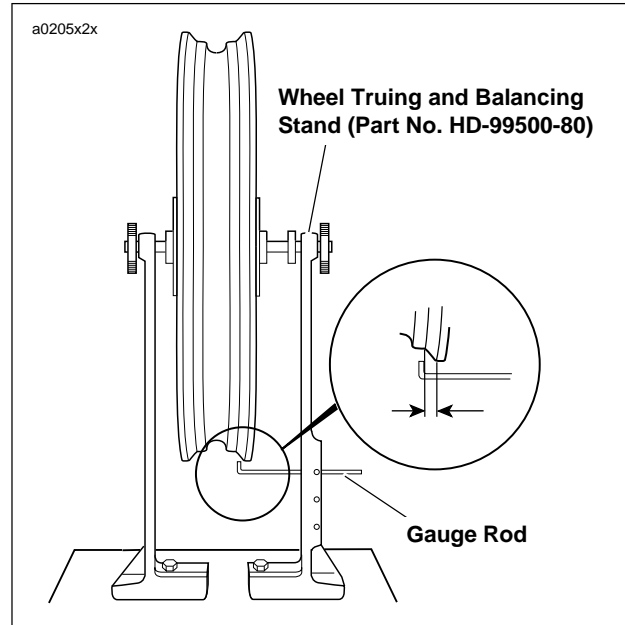

Figure 2-18. Checking Cast Rim Lateral Runout

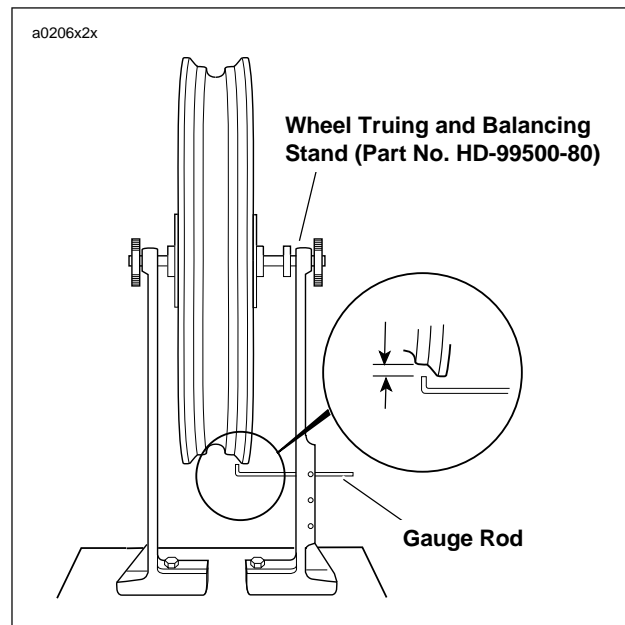

Figure 2-19. Checking Cast Rim Radial Runout

GENERAL

Inspect tires for punctures, cuts, breaks and wear at least weekly.

⚠ WARNING

Always check both tire sidewalls for arrows indicating forward rotation. Some tires require different tire rotation depending on whether tire is used on front or rear wheel. Installing a tire with the wrong rotation may lead to tire failure which could result in death or serious injury.

⚠ WARNING

Dunlop front and rear tires for Buell motorcycles are not the same. They are not interchangeable. Use front tire ONLY for a front tire. DO NOT put a rear tire on the front of a vehicle. Failure to follow this warning could result in death or serious injury.

Some tires have arrows molded into the tire sidewall. These tires should be mounted on the rim with the arrow pointing in the direction of forward rotation. The red circle on the sidewall is a balance mark and should be located next to the valve stem hole.

REMOVAL

1. Remove wheel from motorcycle. See [2.6 FRONT WHEEL](#) or [2.7 REAR WHEEL](#).
2. **Rear wheel only:** Remove rear sprocket. See [2.7 REAR WHEEL \(Disassembly\)](#).
3. Deflate tire.
4. See [Figure 2-20](#). Loosen both tire beads from rim flange.

⚠ WARNING

Do not use excessive force when starting bead over rim. Excessive force may damage tire or rim and adversely affect handling which could result in death or serious injury.

5. If a bead breaker machine is not available, attach RIM PROTECTORS (Part No. HD-01289) to the rim. Using tire tools (not sharp instruments), start upper bead over edge of rim at valve. Repeat all around rim until first bead is over rim.
6. See [Figure 2-21](#). Push lower bead into rim well on one side and insert tire tool underneath bead from opposite side. Pry bead over rim edge. Remove tire from rim.
7. Remove valve stem if it is damaged or leaks.
8. Mount tire on TIRE SPREADER (Part No. HD-21000) for inspection and repair procedures.

CLEANING AND INSPECTION

1. Clean inside of tire.
2. If rim is dirty or corroded, clean with a stiff wire brush.
3. Inspect tire for wear and damage. Replace worn tires.

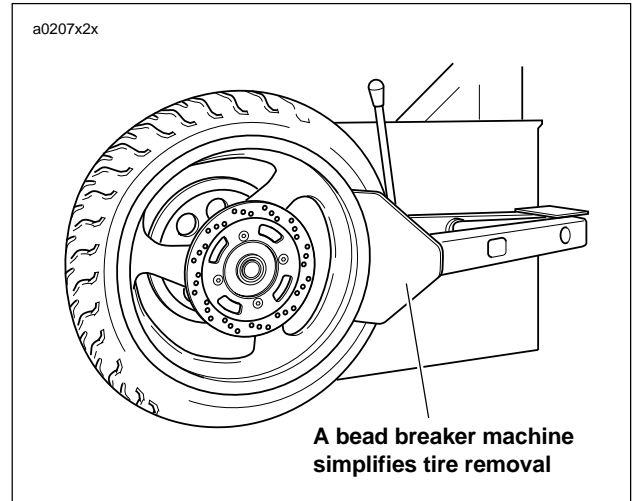

Figure 2-20. Loosening Beads from Rim Flange (Typical)

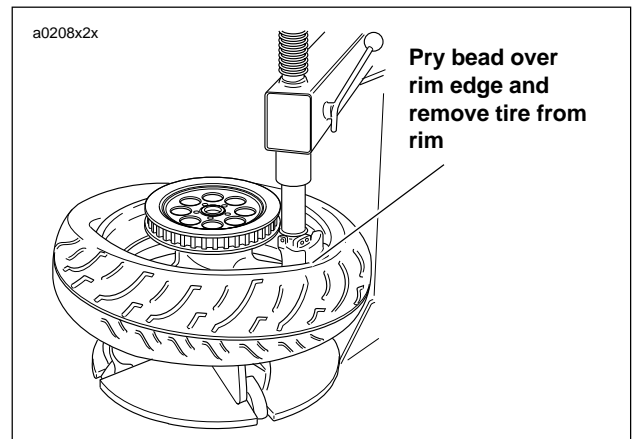

Figure 2-21. Starting Tire Off Rim (Typical)

INSTALLATION

WARNING

Only install original equipment (stock) tire valves and valve caps. A valve or valve and cap combination that is too long may interfere with (strike) adjacent components, damage the valve and cause rapid tire deflation. Rapid tire deflation could cause loss of control which could result in death or serious injury.

WARNING

Aftermarket valve caps that are heavier than the stock cap may have clearance at slow speeds; but, at high speed the valve/cap will be moved outward by centrifugal force. This outward movement could cause the valve/cap to strike the adjacent components, damage the valve and cause rapid tire deflation. Rapid tire deflation could cause loss of control which could result in death or serious injury.

1. Damaged or leaking valve stems must be replaced. Place rubber grommet on valve stem with shoulder in recess of the valve stem head.
2. Install and tighten nut to 42-44 **in-lbs** (4.7-5.0 Nm).
3. Thoroughly lubricate rim flanges and both beads of tire with tire lubricant.
4. See [Figure 2-22](#). Starting at the valve stem, start first bead into the rim well using a bead breaker machine. If no machine is available, work bead on as far as possible by hand. Use a tire tool to pry the remaining bead over rim flange.
5. Start 180° from valve stem hole and place second bead on rim. Work bead onto rim with tire tools, working toward valve in both directions.

WARNING

Do not inflate over 40 psi (276 kPa) to seat the beads. Inflating the tire beyond 40 psi (276 kPa) to seat the beads can cause the tire rim assembly to burst with force which could result in death or serious injury.

6. Apply air to stem to seat beads on rim. It may be necessary to use a TIRE BEAD EXPANDER (Part No. HD-28700) on the tire until beads seal on rim.

Checking Tire Lateral Runout

1. See [Figure 2-23](#). Turn wheel on axle and measure amount of displacement from a fixed point to tire side-wall.
2. Tire tread lateral runout should be no more than 0.080 in. (2.03 mm). If runout is more than 0.080 in. (2.03 mm), remove tire from rim.
3. Check rim bead side runout. See [2.9 CHECKING CAST RIM RUNOUT](#). Replace rims not meeting specifications.
4. Install tire and check again for tire tread lateral runout.

Checking Tire Radial Runout

1. See [Figure 2-24](#). Turn wheel on axle and measure tread radial runout.
2. Tire tread radial runout should not be greater than 0.060 in. (1.52 mm). If runout exceeds specification, remove tire from rim.
3. Check rim bead runout. See [2.9 CHECKING CAST RIM RUNOUT](#). Replace rims not meeting specifications.
4. Install tire and check tire tread radial runout again.

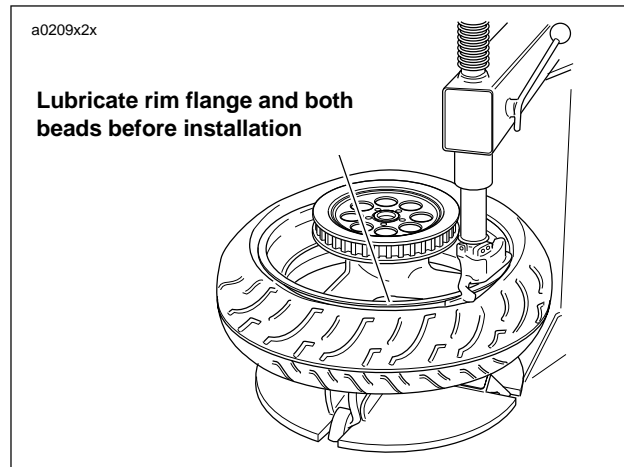

Figure 2-22. Starting Bead on Rim (Typical)

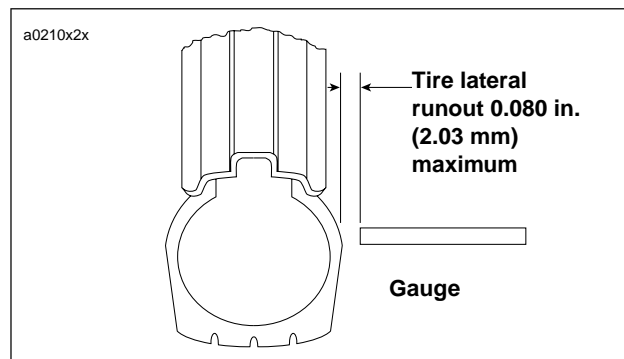

Figure 2-23. Checking Tire Lateral Runout

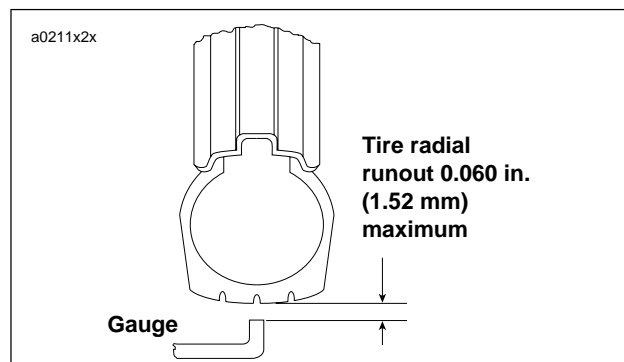

Figure 2-24. Checking Tire Radial Runout

ADJUSTMENT

Wheel Balancing

Wheel balancing is recommended to improve handling and reduce vibration, especially at high road speeds.

In most cases, static balancing using WHEEL TRUING AND BALANCING STAND (Part No. HD-99500-80) will produce satisfactory results. However, dynamic balancing, utilizing a wheel spinner, can be used to produce finer tolerances for better high-speed handling characteristics. Follow the instructions supplied with the balance machine you are using.

WEIGHTS FOR CAST WHEELS

The maximum weight permissible to accomplish balance is:

- 1.0 oz. (28 g) total weight applied to the front wheel.
- 2.0 oz. (56 g) total weight applied to the rear wheel.

Wheels should be balanced to within 1/4 oz. (7 g) at 60 MPH (97 KM/H).

See [Figure 2-25](#). Use only WHEEL WEIGHTS (Part No. 43692-94Y) which have special self-adhesive backings. Apply WHEEL WEIGHTS to the flat surface of the wheel rim.

1. Make sure that area of application is completely clean, dry and free of oil and grease.
2. Remove paper backing from weight. For additional adhesive strength, apply three drops of LOCTITE SUPER-BONDER 420 to adhesive side of weight.
3. Place weight on flat surface of wheel rim.
4. Press weight firmly in place and hold for ten seconds.
5. Allow eight hours for adhesive to cure completely before using wheel.

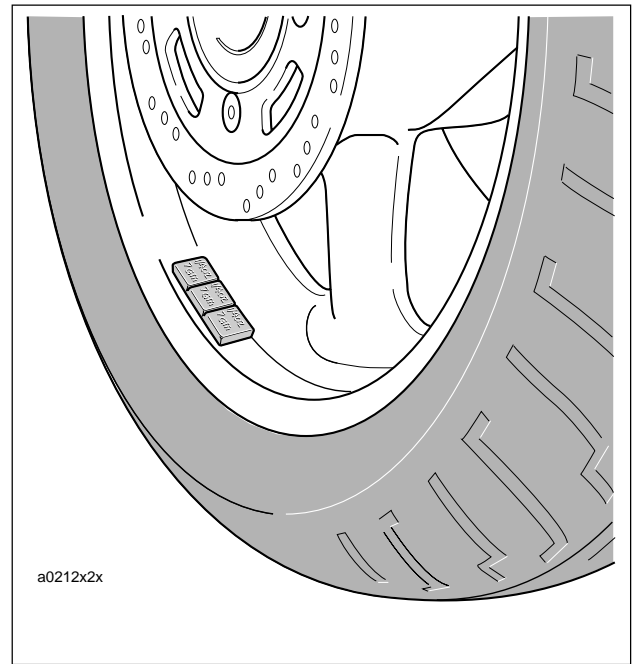

Figure 2-25. Wheel Weights (Typical)

REMOVAL

NOTE

Do not remove the master cylinder unless problems are being experienced.

1. See Figure 2-26. Drain brake fluid into a suitable container. Discard used fluid according to local laws.
 - a. Open bleeder valve (metric) about 1/2-turn.
 - b. Install a length of plastic tubing over caliper bleeder valve. Place free end in a suitable container.
 - c. Pump brake hand lever to drain brake fluid.
 - d. Tighten bleeder valve to 3-5 ft-lbs (4.1-6.8 Nm)
2. Remove mirror from right handlebar.

CAUTION

Damaged banjo bolt seating surfaces will leak when reassembled. Prevent damage to seating surfaces by carefully removing brake line components.

3. See Figure 2-27. Remove banjo bolt (6) (metric) and two banjo washers (4) to disconnect brake line (5) from master cylinder. Discard banjo washers.
4. Unplug both terminals to detach brake lamp switch.

NOTE

The individual parts of the brake lamp switch are not serviceable. Replace switch upon failure.

5. Remove two screws (1) (metric) and clamp (2) to detach master cylinder assembly from handlebar.

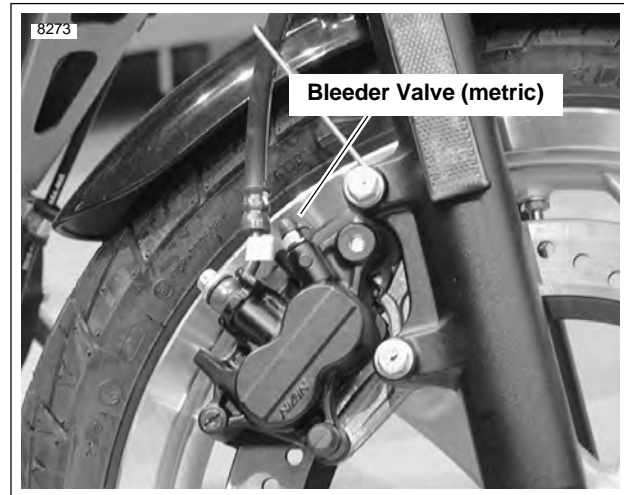
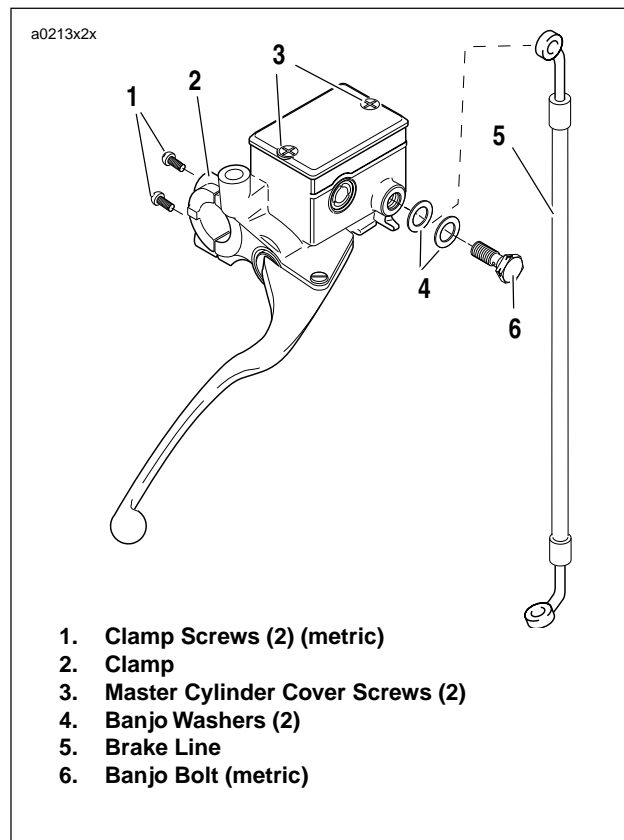

Figure 2-26. Draining Front Brake System



1. Clamp Screws (2) (metric)
2. Clamp
3. Master Cylinder Cover Screws (2)
4. Banjo Washers (2)
5. Brake Line
6. Banjo Bolt (metric)

Figure 2-27. Front Master Cylinder

DISASSEMBLY

- See [Figure 2-28](#). Detach front brake hand lever.
 - Remove nut (1) (metric) from lever pivot.
 - Remove pivot bolt (2) from lever pivot.
- Detach front brake hand lever (3) from master cylinder assembly.
- See [Figure 2-29](#). Remove screw, lockwasher and washer (1) holding front brake switch (3) to master cylinder assembly. Remove switch.
- See [Figure 2-30](#). Compress piston (2) and remove rubber boot (1).
- Depress piston assembly and remove internal snap ring (3). Discard snap ring.
- See [Figure 2-31](#). Remove piston assembly (1-4) from front master cylinder.

CLEANING AND INSPECTION

⚠ WARNING

Clean brake system components using denatured alcohol. Do not use mineral-base cleaning solvents, such as gasoline or paint thinner. Use of mineral-base solvents causes deterioration of rubber parts that continues after assembly. This could result in improper brake operation which could result in death or serious injury.

- Clean all parts with denatured alcohol or **D.O.T. 4 BRAKE FLUID**. Do not contaminate with mineral oil or other solvents. Wipe dry with a clean, lint free cloth. Blow out drilled passages and bore with a clean air supply. Do not use a wire or similar instrument to clean drilled passages in bottom of reservoir.
- Carefully inspect all parts for wear or damage and replace as necessary.
- Inspect piston bore in master cylinder housing for scoring, pitting or corrosion. Replace housing if any of these conditions are found.
- Inspect outlet port that mates with brake line fitting. As a critical sealing surface, replace housing if any scratches, dents or other damage is noted.
- Inspect boot for cuts, tears or general deterioration. Replace as necessary.

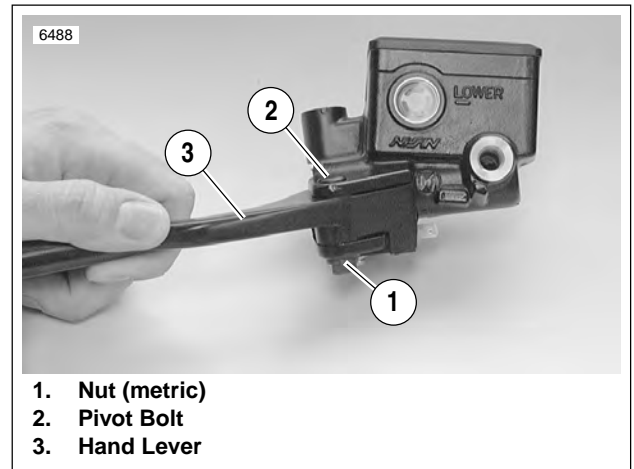

Figure 2-28. Hand Lever

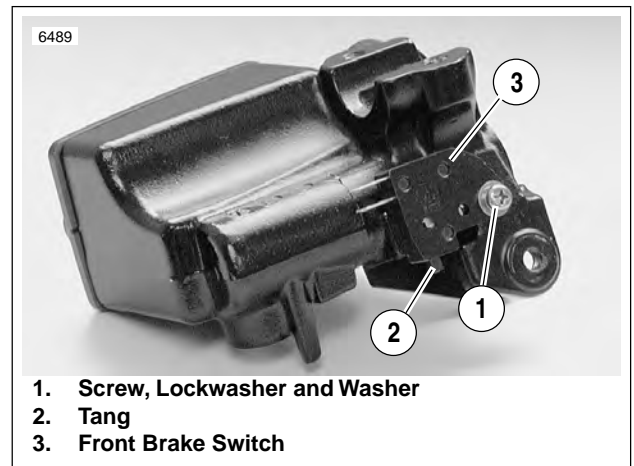

Figure 2-29. Front Brake Switch

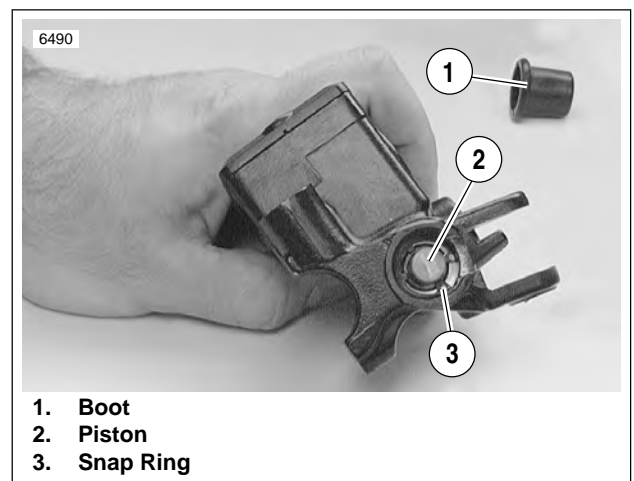

Figure 2-30. Snap Ring

ASSEMBLY

1. See [Figure 2-31](#). Check piston assembly components.
 - a. Small end of spring (1) sits behind primary cup (2). Large side of primary cup faces spring.
 - b. Secondary cup (3) sits within ridge at middle of piston (4).
2. Insert piston assembly, spring first, into master cylinder. Secure with a **new** snap ring (6).
3. Install ridge on boot (5) into groove on piston (4).
4. See [Figure 2-28](#). Install front brake hand lever.
 - a. Align hole in lever (3) with hole in master cylinder assembly.
 - b. Lubricate pivot bolt (2) with LOCTITE ANTI-SEIZE.
 - c. Install pivot bolt through top of assembly. Tighten to 4-13 **in-lbs** (0.5-1.5 Nm).
 - d. Install nut (1) (metric). Tighten to 44-62 **in-lbs** (5.0-7.0 Nm).
5. See [Figure 2-27](#). Install front brake lamp switch (7).
 - a. Attach front brake switch with screw, washer and lockwasher (1). Tighten to 7-13 **in-lbs** (0.8-1.5 Nm).
 - b. Test switch action. Tang (3) on switch must release when hand lever (2) is moved.

INSTALLATION

1. See [Figure 2-27](#). Fasten master cylinder to handlebar by installing clamp (2) and screws (1) (metric). Tighten to 80-120 **in-lbs** (9.0-13.6 Nm).

WARNING

Use only new black banjo washers (See Parts Catalog for Part No.) with D.O.T. 4 brake fluid. Earlier silver banjo washers are not compatible with D.O.T. 4 fluid and will not seal properly over time. Failure to comply may adversely affect braking ability and lead to brake failure which could result in death or serious injury.

CAUTION

To avoid leakage, ensure that banjo washers, banjo bolt, hydraulic brake line and master cylinder bore are completely clean.

2. Connect brake line (5) to master cylinder using two **new** banjo washers (4) and banjo bolt (6) (metric). Tighten to 16-20 ft-lbs (21.7-27.1 Nm).
3. See [Figure 2-32](#). Verify brake lamp switches are secure. Attach wires to switches.
4. Install mirror parallel to handlebars.
5. See [Figure 2-27](#). Remove the two master cylinder cover screws (3), cover and cover gasket.
6. See [Figure 2-33](#). With the master cylinder in a level position, add **D.O.T. 4 BRAKE FLUID**. Bring fluid level to within 0.125 in. (3.2 mm) of molded boss inside front master cylinder reservoir.

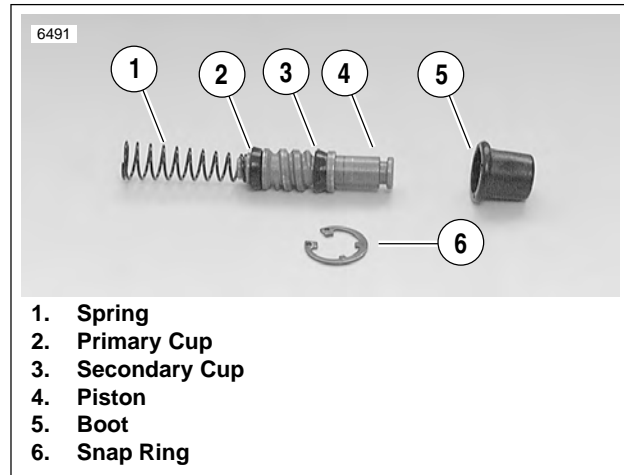

Figure 2-31. Piston Assembly

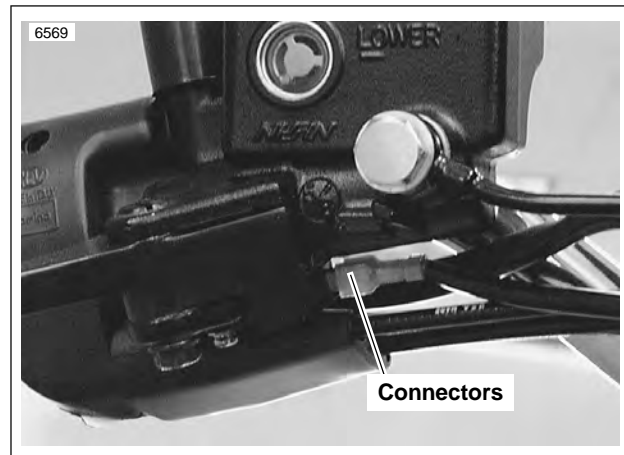

Figure 2-32. Brake Lamp Switch Connectors

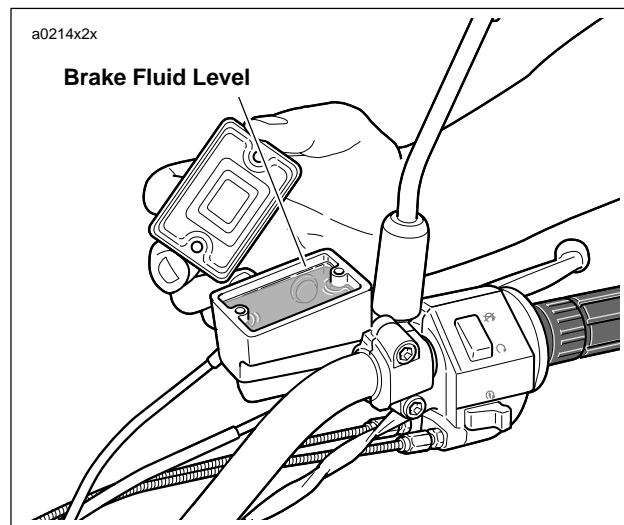

Figure 2-33. Brake Fluid Level

WARNING

See [Figure 2-34](#). Verify proper operation of the master cylinder relief port. A plugged or covered relief port can cause brake drag or lockup, which could result in loss of vehicle control and death or serious injury

7. See [Figure 2-34](#). Verify proper operation of the master cylinder relief port.
8. See [Figure 2-35](#). Actuate the brake lever with the reservoir cover removed. A slight spurt of fluid will break the surface if all internal components are working properly.
9. See [Figure 2-27](#). Attach master cylinder cover and cover gasket with the two cover screws (3). Tighten to 9-13 in-lbs (1.0-1.5 Nm).
10. Bleed brake system. See [1.6 BRAKE SYSTEM MAINTENANCE](#).

WARNING

Check for proper brake lamp operation before riding motorcycle. Visibility is a major concern for motorcyclists. Failure to have proper brake lamp operation could result in death or serious injury.

11. Turn ignition key switch to IGN. Apply brake hand lever to test brake lamp operation. Turn ignition switch to LOCK.

WARNING

Always test motorcycle brakes at low speed after servicing or bleeding system. If brakes are not operating properly, or braking efficiency is poor, testing at high speeds could result in death or serious injury.

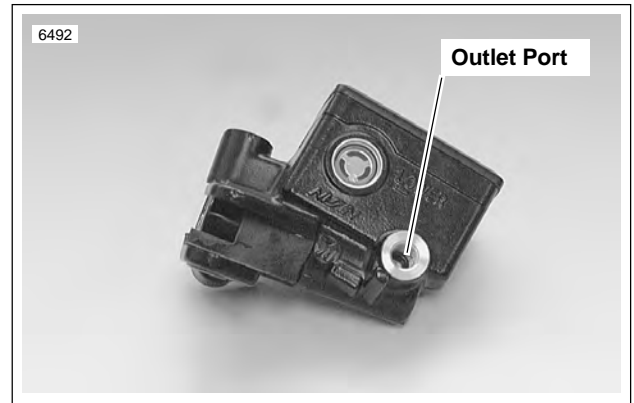
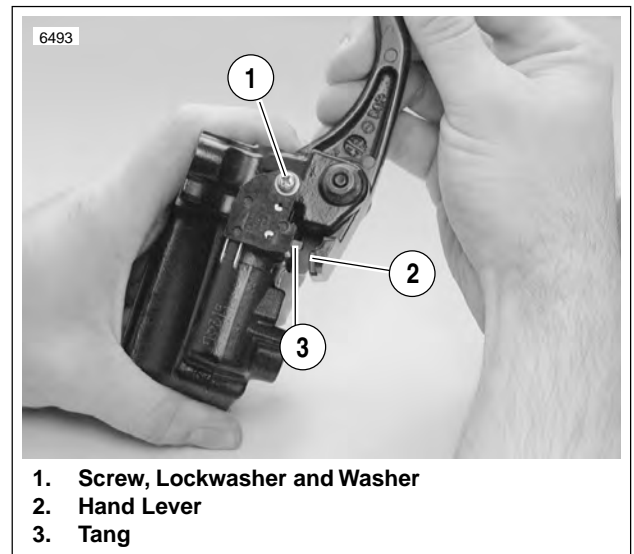

Figure 2-34. Master Cylinder Body



1. Screw, Lockwasher and Washer
2. Hand Lever
3. Tang

Figure 2-35. Testing Hand Lever

REMOVAL

NOTE

Steps 1 and 2 are not required for detaching caliper from rotor. Drain fluid only when disassembling caliper.

1. Drain and discard brake fluid.

CAUTION

Damaged banjo bolt seating surfaces will leak when reassembled. Prevent damage to seating surfaces by carefully removing brake line components.

2. See Figure 2-36. Remove banjo bolt (2) (metric) and two banjo washers (3) to disconnect brake line (1) from caliper. Discard banjo washers.
3. Remove brake pads.
 - a. Remove pin plug (4).
 - b. See Figure 2-37. Remove pad hanger pin (1) (metric).
 - c. Remove brake pads from caliper.
4. See Figure 2-36. Detach caliper from mounts.
 - a. Remove lower mounting screw (5).
 - b. Remove upper mounting screw (5) and brake line wireform (7) while supporting caliper above brake rotor.
 - c. Slowly remove caliper by tilting away from wheel and then pulling away from rotor.
 - d. Separate carrier and caliper.

DISASSEMBLY

1. See Figure 2-38. Use BRAKE CALIPER PISTON REMOVER (Part No. B-42887) to pull the two pistons from caliper bores.
2. See Figure 2-39. Remove piston outer seals (4) and inner seals (2) from their respective grooves in caliper. Discard seals.
3. Check bleeder valve (metric). Remove and replace if damaged.

CLEANING AND INSPECTION

WARNING

Clean brake system components using denatured alcohol. Do not use mineral-base cleaning solvents, such as gasoline or paint thinner. Use of mineral-base solvents causes deterioration of rubber parts that continues after assembly. This could result in improper brake operation which could result in death or serious injury.

1. Clean all parts with denatured alcohol or **D.O.T. 4 BRAKE FLUID**. Do not contaminate with mineral oil or other solvents. Wipe dry with a clean, lint free cloth. Blow out drilled passages and bore with a clean air supply. Do not use a wire or similar instrument to clean drilled passages.

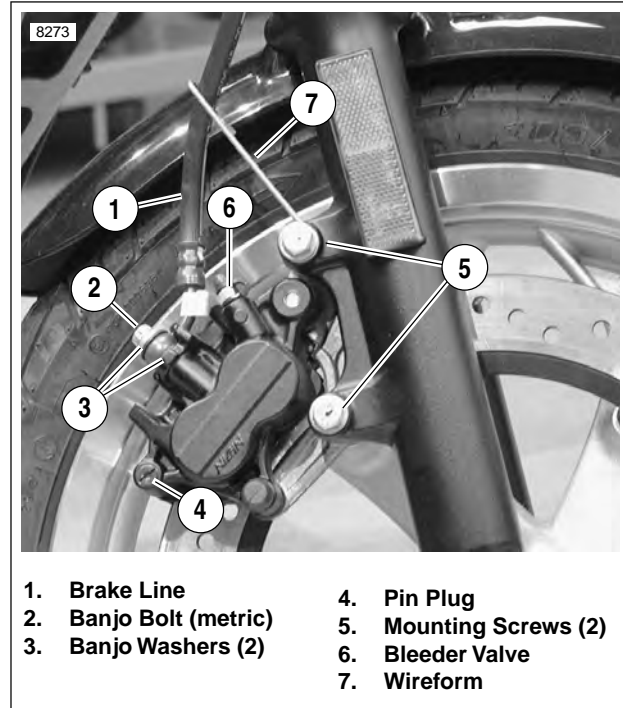

Figure 2-36. Front Brake Caliper

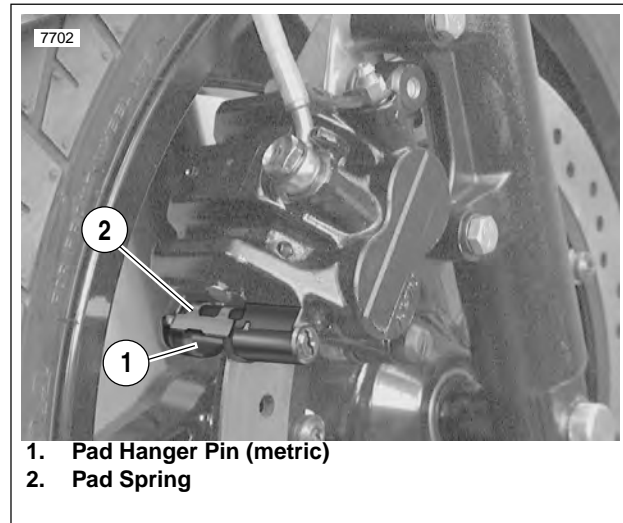

Figure 2-37. Pad Spring

2. Carefully inspect all components. Replace any parts that appear damaged or worn. Do not hone caliper piston bore.
3. Inspect brake rotor.
 - a. Measure rotor thickness. Replace if minimum thickness is less than 0.18 in. (4.5 mm).
 - b. Check rotor surface. Replace if warped or badly scored.

⚠ WARNING

Always replace brake pads in complete sets for correct brake operation. Never replace just one brake pad. Failure to install brake pads as a set could result in death or serious injury.

4. Inspect brake pads for damage or excessive wear. Replace both pads as a set if the friction material of either pad is worn to 0.04 in. (1.0 mm) or less.

ASSEMBLY

1. See [Figure 2-39](#). Install pistons and O-rings.
 - a. Apply a light coat of **D.O.T. 4 BRAKE FLUID** to seals, pistons and caliper piston bores.
 - b. Install two **new** seals in outer grooves of each piston bore.
 - c. Install two **new** seals in inner grooves of each piston bore.
 - d. Install pistons (3) in each piston bore.
2. Install a **new** bleeder valve (metric) if necessary. Tighten to 3-5 ft-lbs (4.1-6.8 Nm).

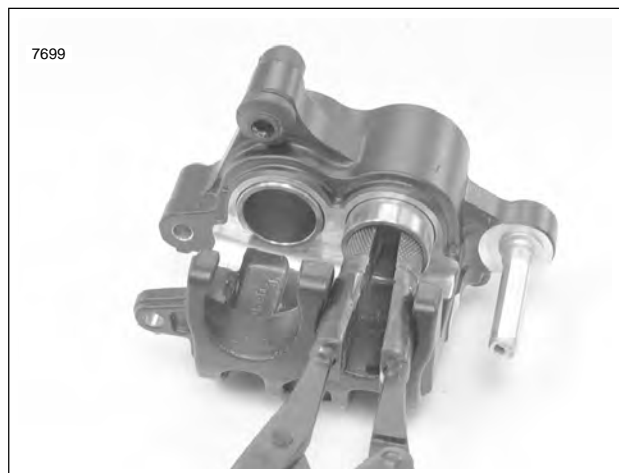

Figure 2-38. Removing Pistons

INSTALLATION

1. Fit front brake caliper on rotor.
 - a. Slide carrier on caliper.
 - b. Slide caliper over front brake rotor without brake pads installed.
2. See [Figure 2-36](#). Apply LOCTITE THREADLOCKER 272 (red) to both caliper mounting screws (5). Install wireform

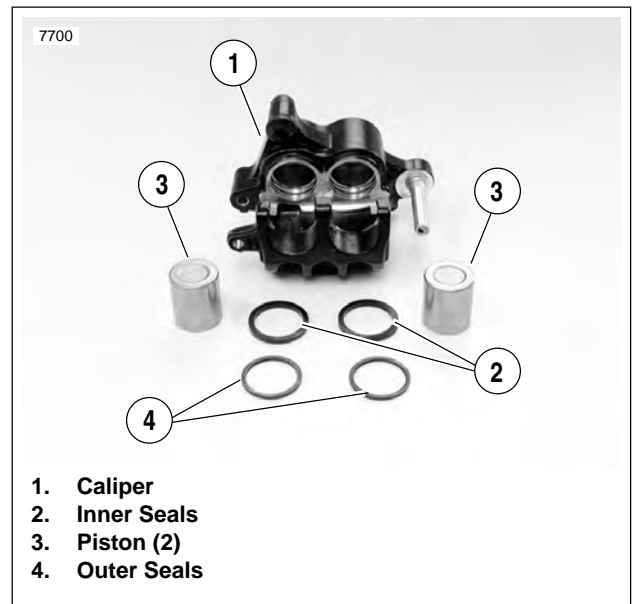

Figure 2-39. Caliper O-rings and Pistons

1. Caliper
 2. Inner Seals
 3. Piston (2)
 4. Outer Seals
- to upper screw and tighten both screws to 18-22 ft-lbs (24.4-29.8 Nm).
 3. Install brake pads.
 - a. See [Figure 2-37](#). Install pad spring (2) with opening at top as shown.
 - b. Insert inboard brake pad from rear of caliper.
 - c. Insert outboard pad.
 - d. See [Figure 2-37](#). Install pad hanger pin (1) (metric). Tighten to 11-14.5 ft-lbs (14.7-19.6 Nm).
 - e. See [Figure 2-36](#). Install pin plug (4). Tighten to 1.5-2.1 ft-lbs (2.0-2.9 Nm).

⚠ WARNING

Use only new black banjo washers (See Parts Catalog for Part No.) with D.O.T. 4 brake fluid. Earlier silver banjo washers are not compatible with D.O.T. 4 fluid and will not seal properly over time. Failure to comply may adversely affect braking ability and lead to brake failure which could result in death or serious injury.

CAUTION

To avoid leakage, verify that banjo washers, banjo bolt, hydraulic brake line and caliper bore are completely clean.

4. Connect brake line (1) to caliper using two **new** banjo washers (3) and banjo bolt (2) (metric). Tighten to 16-20 ft-lbs (21.7-27.1 Nm).
5. Route brake line through wireform.

CAUTION

Cover molded-in-color surfaces and right handlebar switches and use care when removing brake reservoir cover and adding D.O.T. 4 brake fluid. Spilling D.O.T. 4 brake fluid on molded-in-color surfaces will result in cosmetic damage. Spilling brake fluid on switches may render them inoperative.

6. See Figure 2-40. Remove both master cylinder cover screws (2). Remove master cylinder cover (1) and gasket.
7. With the master cylinder in a level position, verify that the brake fluid level is 0.125 in. (3.2 mm) from molded boss inside reservoir. Add **D.O.T. 4 BRAKE FLUID** if necessary.

WARNING

Verify proper operation of the master cylinder relief port. A plugged or covered relief port can cause brake drag or lockup, which could result in loss of vehicle control and death or serious injury

8. Verify proper operation of the master cylinder relief port. Actuate the brake lever with the reservoir cover removed. A slight spurt of fluid will break the surface if all internal components are working properly.
9. Install master cylinder cover (1) and cover gasket with two screws (2). Tighten to 9-13 **in-lbs** (1.0-1.5 Nm).
10. Depress front brake lever several times to set brake pads to proper operating position within caliper. Bleed brake system.

WARNING

Check for proper brake lamp operation before riding motorcycle. Visibility is a major concern for motorcyclists. Failure to have proper brake lamp operation could result in death or serious injury.

11. Turn ignition key switch to IGN. Apply brake hand lever to test brake lamp operation. Turn ignition key switch to LOCK.

WARNING

Always test motorcycle brakes at low speed after servicing or bleeding system. If brakes are not operating properly, or braking efficiency is poor, testing at high speeds could result in death or serious injury.

NOTE

Avoid making hard stops for the first 100 miles (160 km) to allow **new** brake pads to “wear in” properly with the brake rotor.

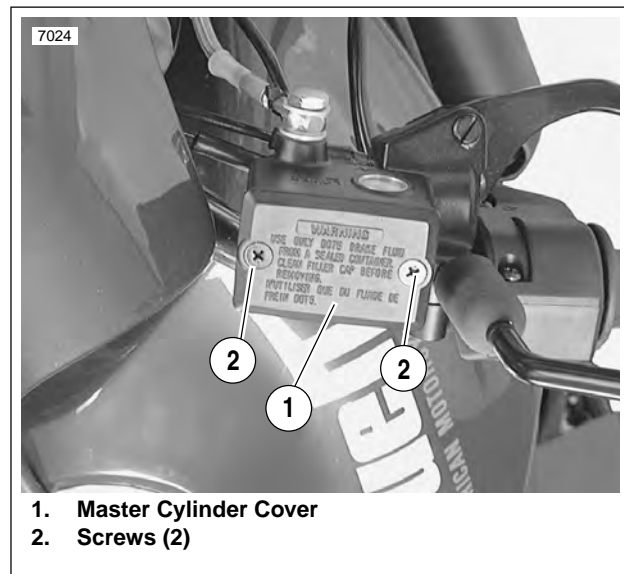

Figure 2-40. Master Cylinder Cover

REMOVAL

1. Drain and discard brake fluid. See Step 1 under 2.11 FRONT BRAKE MASTER CYLINDER.
2. See Figure 2-41. Remove screw (4) to detach brake line clamp (5) from right side of lower triple clamp. Remove brake line from wireform.

CAUTION

Damaged banjo bolt seating surfaces will leak when reassembled. Prevent damage to seating surfaces by carefully removing brake line components.

3. Remove master cylinder banjo bolt (1) (metric) and two banjo washers (2) to disconnect brake line from master cylinder. Discard banjo washers.
4. Remove caliper banjo bolt (6) (metric) and two banjo washers (7) to disconnect brake line from caliper. Discard banjo washers.
5. Carefully inspect the brake line for dents, cuts or other defects. Replace the brake line if any damage is noted.

INSTALLATION

WARNING

Use only new black banjo washers (See Parts Catalog for Part No.) with D.O.T. 4 brake fluid. Earlier silver banjo washers are not compatible with D.O.T. 4 fluid and will not seal properly over time. Failure to comply may adversely affect braking ability and lead to brake failure which could result in death or serious injury

CAUTION

To avoid leakage, ensure that banjo washers, banjo bolt, hydraulic brake line and master cylinder bore are completely clean.

1. See Figure 2-41. Connect brake line to master cylinder using two **new** banjo washers (2) and banjo bolt (1) (metric). Loosely install bolt into master cylinder.
2. From the master cylinder, the brake line runs downward in front of the right handlebar, where it turns inboard at the upper triple clamp. Loosely install clamp (5) with screw (4) to attach front brake line to right side of lower triple clamp. Position brake line in wireform.
3. Connect brake line to caliper using two **new** banjo washers (7) and banjo bolt (6) (metric). Tighten banjo bolt (6) to 16-20 ft-lbs (21.7-27.1 Nm).
4. Tighten clamp screw (4) on lower triple clamp to 3-5 ft-lbs (4.1-6.8 Nm).
5. Tighten master cylinder banjo bolt (1) (metric) to 16-20 ft-lbs (21.7-27.1 Nm).
6. Install bleeder valve if removed. Refill master cylinder and bleed brakes.

WARNING

Check for proper brake lamp operation before riding motorcycle. Visibility is a major concern for motorcyclists. Failure to have proper brake lamp operation could result in death or serious injury.

7. Turn ignition key switch to IGN. Apply brake hand lever to test brake lamp operation. Turn ignition key switch to LOCK.

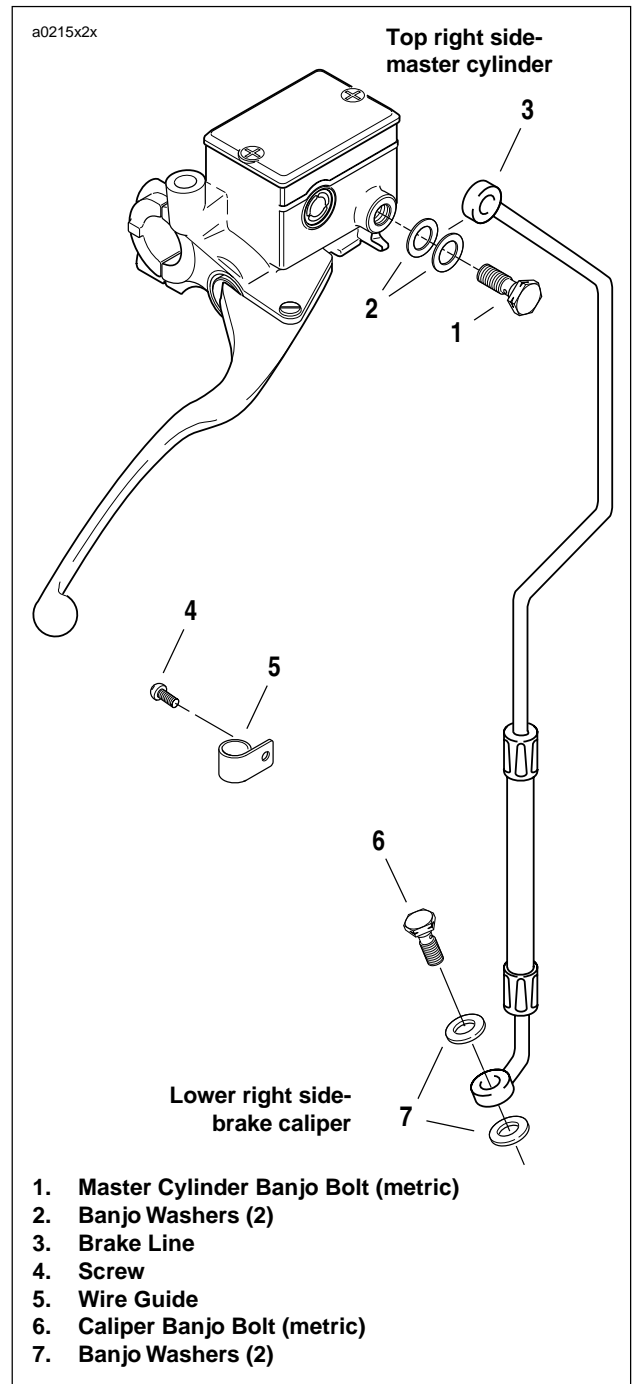

Figure 2-41. Front Brake Line

REMOVAL

1. See Figure 2-42. Drain brake fluid into a suitable container. Discard used fluids according to local laws.
 - a. Remove cap from rear caliper bleeder valve. Open bleeder valve (metric) about 1/2 turn.
 - b. Install a length of plastic tubing over caliper bleeder valve. Place free end in a suitable container.
 - c. Pump brake pedal to drain brake fluid.
 - d. Tighten bleeder valve (metric) to 3-5 ft-lbs (4.1-6.8 Nm). Reinstall cap.

CAUTION

Damaged banjo bolt surfaces will leak when reassembled. Prevent damage to seating surfaces by carefully removing brake line components.

2. See Figure 2-43. Remove banjo bolt (1) (metric) and two banjo washers (2) to detach brake line (3) from master cylinder (4). Discard banjo washers.
3. See Figure 2-43. Disconnect push rod from brake pedal clevis (11).
 - a. Spin locknut (10) away from top surface of clevis.
 - b. Turn rod adjuster (7) to free rod from clevis (11).
4. See Figure 2-44. Remove two screws (2) and spacers (3) to detach master cylinder from footrest support.
5. See Figure 2-45. Detach remote reservoir.

DISASSEMBLY

NOTE

Do not disassemble master cylinder unless problems are experienced. Discard all seals during the disassembly procedure. Install a complete rebuild kit upon assembly.

1. See Figure 2-46. Slide rubber boot on rod assembly (3) away from master cylinder body (1).
2. Depress rod assembly (3) and remove internal snap ring (2). Discard snap ring.
3. Remove piston assembly (4) from master cylinder body.

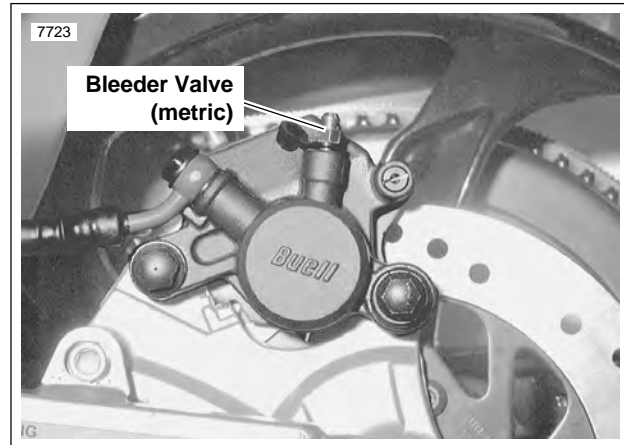

Figure 2-42. Rear Caliper Bleeder Valve (Metric)

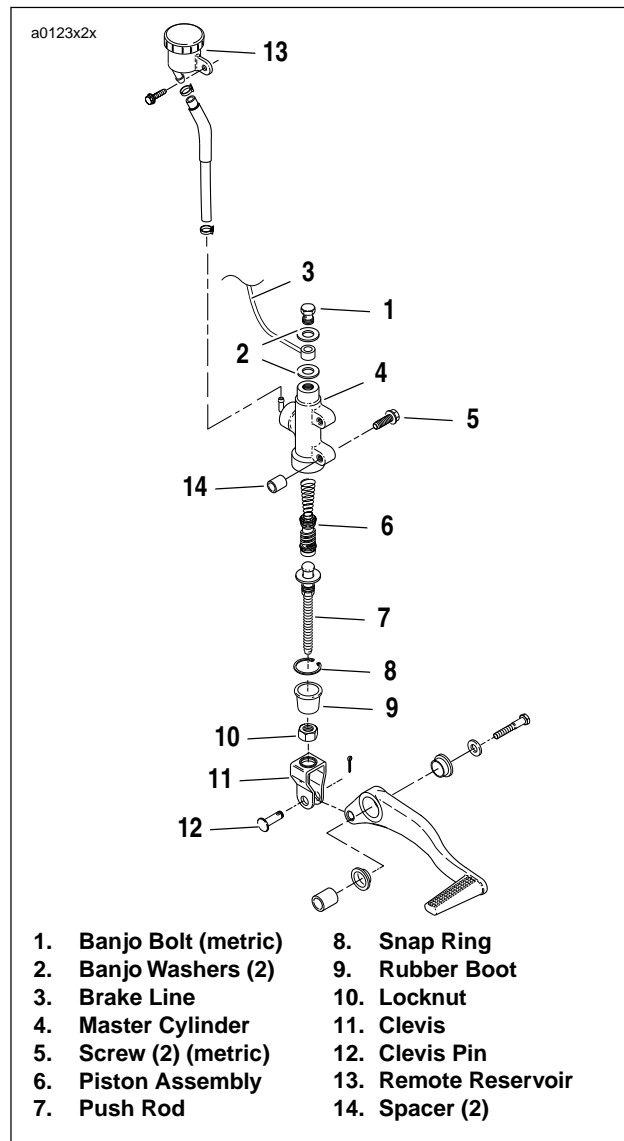

Figure 2-43. Rear Master Cylinder Assembly

CLEANING AND INSPECTION

WARNING

Clean brake system components using denatured alcohol. Do not use mineral-base cleaning solvents, such as gasoline or paint thinner. Use of mineral-base solvents causes deterioration of rubber parts that continues after assembly. This could result in improper brake operation which could result in death or serious injury.

1. Thoroughly clean master cylinder and all brake system components. Stand master cylinder on wooden block or towel to protect seating surfaces.
 - a. Examine walls of master cylinder reservoir for scratches and grooves. Replace if damaged.
 - b. Verify that vent holes on master cylinder are completely open and free of dirt or debris.
2. Inspect boot on front of master cylinder for cuts, tears or general deterioration. Replace if necessary.

ASSEMBLY

1. See Figure 2-46. Insert piston assembly (4), spring first, into master cylinder.
2. Place round side of rod assembly (3) over piston. Depress piston into master cylinder body (1) and secure with a **new** snap ring (2).
3. Tuck rubber boot on rod assembly (3) into master cylinder body (1).

INSTALLATION

1. See Figure 2-45. Connect remote reservoir.
 - a. If removed, attach remote reservoir to frame using screw. Tighten to 12-15 **in-lbs** (1.4-1.7 Nm).
 - b. Attach reservoir hose to master cylinder with clamp (if removed).
2. See Figure 2-44. Apply LOCTITE THREADLOCKER 243 (blue) to both screws. Attach master cylinder (3) to frame with spacers between master cylinder and footrest support. Tighten to 8-10 **ft-lbs** (10.8-13.6 Nm).

WARNING

Use only new black banjo washers (See Parts Catalog for Part No.) with D.O.T. 4 brake fluid. Earlier silver banjo washers are not compatible with D.O.T. 4 fluid and will not seal properly over time. Failure to comply may adversely affect braking ability and lead to brake failure which could result in death or serious injury.

CAUTION

To avoid leakage after assembly, verify that banjo washers, banjo bolt, hydraulic brake line and bore of master cylinder are completely clean.

3. See Figure 2-43. Connect brake line (3) to master cylinder (4) with two **new** banjo washers (2) and banjo bolt (1) (metric). Tighten to 16-20 **ft-lbs** (21.7-27.1 Nm).

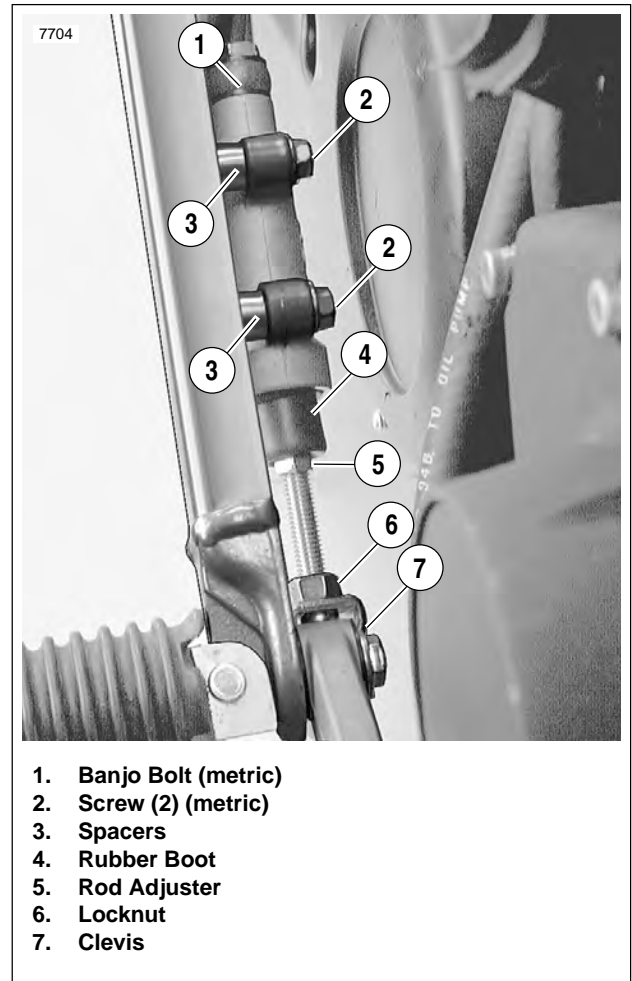

1. Banjo Bolt (metric)
2. Screw (2) (metric)
3. Spacers
4. Rubber Boot
5. Rod Adjuster
6. Locknut
7. Clevis

Figure 2-44. Master Cylinder Mounting

4. Install push rod.
 - a. Screw push rod into clevis.

NOTE

Brake pedal height should be set so top surface of brake pedal is even with the top surface of the foot peg.

5. See Figure 2-44. Set brake pedal height.
 - a. Loosen locknut (6).
 - b. Turn rod adjuster (5) to obtain correct position.
 - c. Tighten locknut (6).

WARNING

Verify proper operation of the master cylinder relief port. A plugged or covered relief port can cause brake drag or lockup, which could result in loss of vehicle control and death or serious injury

6. Add brake fluid and bleed brake system. See [Bleeding Brakes](#).
7. With motorcycle in a level position, check that brake fluid is between the upper and lower marks on reservoir. Add **D.O.T. 4 BRAKE FLUID** if necessary. Be sure gasket and cap on reservoir fit securely.

WARNING

Check for proper brake lamp operation before riding motorcycle. Visibility is a major concern for motorcyclists. Failure to have proper brake lamp could result in death or serious injury.

8. Turn ignition key switch to IGN. Apply rear brake pedal to test brake lamp operation. Turn ignition key switch to LOCK.

WARNING

Always test motorcycle brakes at low speed after servicing or bleeding system. If brakes are not operating properly, or braking efficiency is poor, testing at high speeds could result in death or serious injury.



Figure 2-45. Remote Reservoir

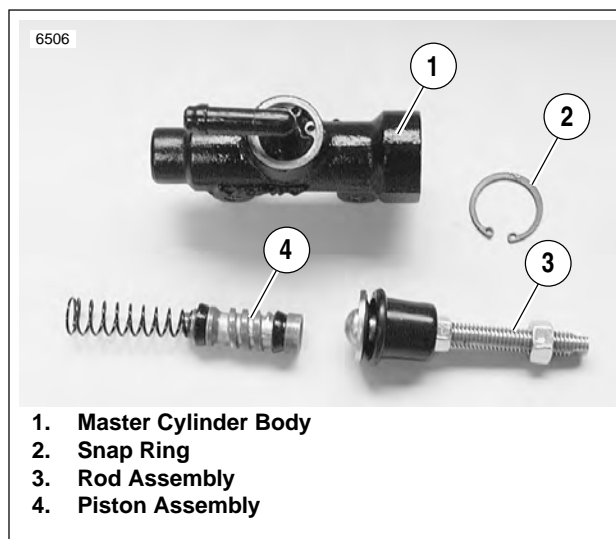

Figure 2-46. Master Cylinder Internals

REMOVAL

NOTE

Steps 1 and 2 are not required for detaching caliper from rotor. Drain fluid only when disassembling caliper.

1. Drain and discard brake fluid.

CAUTION

Damaged banjo bolt seating surfaces will leak when reassembled. Prevent damage to seating surfaces by carefully removing brake line components.

2. See Figure 2-47. Remove banjo bolt (2) (metric) and two banjo washers (3) to disconnect brake line (1) from caliper. Discard banjo washers.
3. Remove small screw (6) (metric) and large screw (7) (metric) to detach caliper from mount.
4. See Figure 2-48. Remove clip (1) from rear caliper mount (2) if necessary.

DISASSEMBLY

1. See Figure 2-47. Remove pin plug and pad hanger (5) (metric) to free brake pads.
2. See Figure 2-48. Remove clip (1) from caliper body.
3. See Figure 2-49. Remove piston (3) using BRAKE CALIPER PISTON REMOVER (1) (Part No. B-42887) with adaptor (2).
4. Remove two O-rings from groove in caliper bore. Discard O-rings.

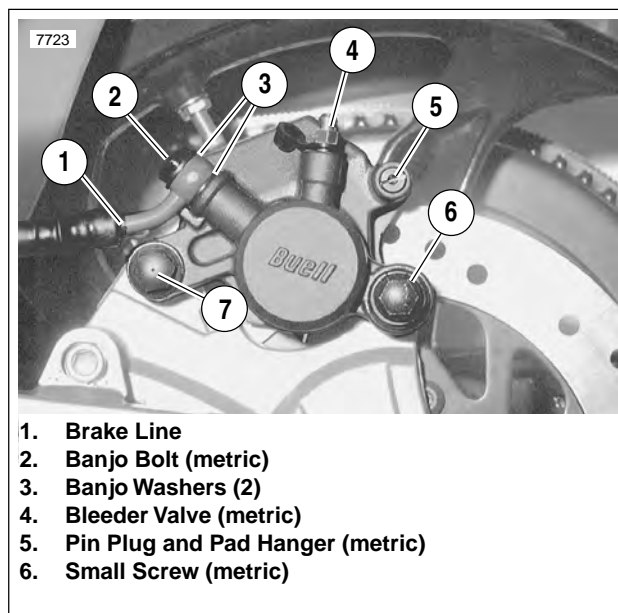

Figure 2-47. Rear Brake Caliper (Typical)

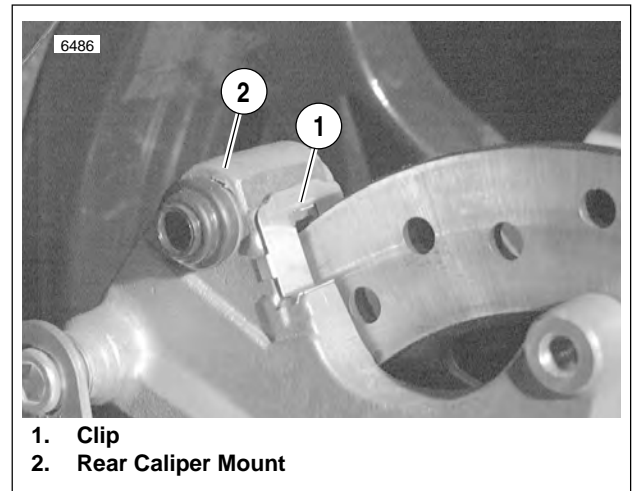

Figure 2-48. Caliper Mount Clip

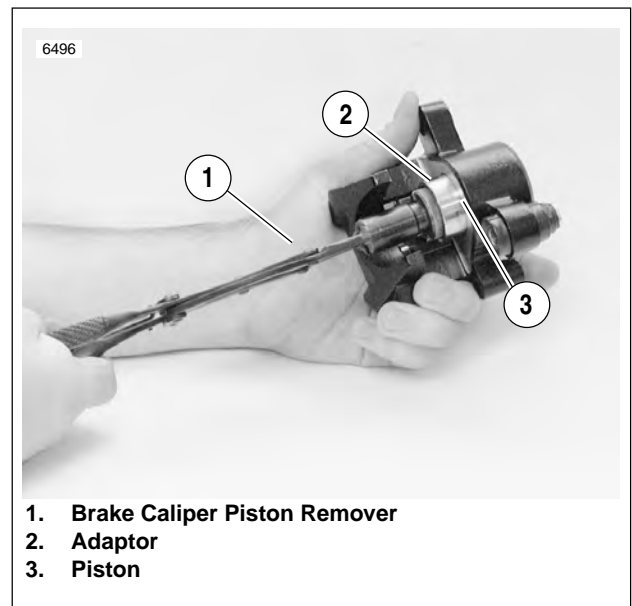

Figure 2-49. Removing Rear Brake Caliper Piston

CLEANING AND INSPECTION

WARNING

Clean brake system components using denatured alcohol. Do not use mineral-base cleaning solvents, such as gasoline or paint thinner. Use of mineral-base solvents causes deterioration of rubber parts that continues after assembly. This could result in improper brake operation which could result in death or serious injury.

- Clean all parts with denatured alcohol or **D.O.T. 4 BRAKE FLUID**. Do not contaminate with mineral oil or other solvents. Wipe dry with a clean, lint free cloth. Blow out drilled passages and bore with a clean air supply. Do not use a wire or similar instrument to clean drilled passages.
- Carefully inspect all components. Replace any parts that appear damaged or worn. Do not hone caliper piston bore.
- Inspect brake rotor.
 - Measure rotor thickness. Replace if minimum thickness is less than 0.18 in. (4.5 mm).
 - Check rotor surface. Replace if warped or badly scored.

WARNING

Always replace brake pads in complete sets for correct brake operation. Never replace just one brake pad. Failure to install brake pads as a set could result in death or serious injury.

- Inspect brake pads for damage or excessive wear. Replace both pads as a set if the friction material of either pad is worn to 0.04 in. (1.0 mm) or less.

ASSEMBLY

- See [Figure 2-50](#). Place clip (1) inside caliper body as shown.

NOTE

To ensure proper brake pad-to-brake rotor clearance when the caliper is installed, piston must be pressed all the way into the bore whenever **new** brake pads are used.

- Install pistons and O-rings.
 - Apply a light coat of **D.O.T. 4 BRAKE FLUID** to O-rings, piston and caliper piston bore.
 - Place **two** new O-rings inside grooves of piston bore.
 - Install piston inside caliper body.
- See [Figure 2-50](#). Install brake pads (3) using pad hanger and pin plug (2).
 - Install pad hanger pin (metric). Tighten to 11-14.5 ft-lbs (14.7-19.6 Nm).
 - Install pin plug. Tighten to 1.5-2.1 ft-lbs (2.0-2.9 Nm).
- Install a **new** bleeder valve (metric) if necessary. Tighten to 3-5 ft-lbs (4.1-6.8 Nm).

INSTALLATION

- See [Figure 2-48](#). Install caliper mount clip (1) if removed.
- See [Figure 2-47](#). Install caliper assembly on caliper mount. Brake pad surfaces must face rear brake rotor.
 - Apply LOCTITE THREADLOCKER 271 (red) to both caliper mounting screws (6, 7) (metric).
 - Install large caliper screw (7) (metric). Tighten to 18-22 ft-lbs (24.4-29.8 Nm)
 - Install small caliper screw (6) (metric). Tighten to 14.5-18 ft-lbs (19.6-24.4 Nm).

WARNING

Use only new black banjo washers (See Parts Catalog for Part No.) with D.O.T. 4 brake fluid. Earlier silver banjo washers are not compatible with D.O.T. 4 fluid and will not seal properly over time. Failure to comply may adversely affect braking ability and lead to brake failure which could result in death or serious injury

CAUTION

To avoid leakage, verify that banjo washers, banjo bolt, hydraulic brake line and caliper bore are completely clean.

- Connect brake line (1) to caliper using two **new** banjo washers (3) and banjo bolt (2) (metric). Tighten to 16-20 ft-lbs (21.7-27.1 Nm).
- Depress rear brake pedal several times to set brake pads to proper operating position within caliper. Bleed brake system.
- Verify proper fluid level in reservoir.

WARNING

Check for proper brake lamp operation before riding motorcycle. Visibility is a major concern for motorcyclists. Failure to have proper brake lamp operation could result in death or serious injury.

- Turn ignition key switch to IGN. Apply brake pedal to test brake lamp operation. Turn ignition key switch to LOCK.

WARNING

Always test motorcycle brakes at low speed after servicing or bleeding system. To prevent death or serious injury, Buell strongly recommends that all brake repairs be performed by a Buell dealer or other qualified technician.

NOTE

Avoid making hard stops for the first 100 miles (160 km) to allow **new** brake pads to “wear in” properly with the brake rot.

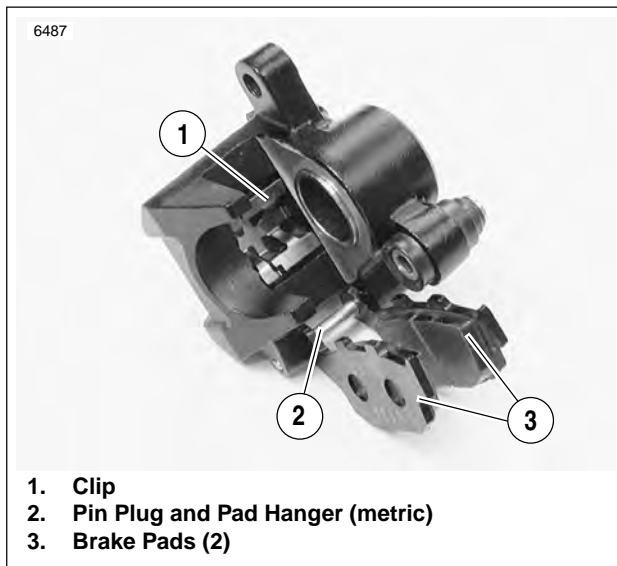

Figure 2-50. Brake Pads

Table 2-4. Brake Troubleshooting

CONDITION	CHECK FOR	REMEDY
Excessive lever/pedal travel or spongy feel.	Air in system.	Bleed brake(s).
	Master cylinder low on fluid.	Fill master cylinder with approved brake fluid.
Brake fade	Moisture in system.	Bleed brake(s).
		Fill master cylinder with approved brake fluid.
Chattering sound when brake is applied.	Worn pads.	Replace brake pads.
	Loose mounting bolts.	Tighten bolts.
	Warped rotor.	Replace rotor.
Ineffective brake – lever/pedal travels to limit.	Low fluid level.	Fill master cylinder with approved brake fluid, and bleed system.
	Piston cup not functioning.	Rebuild cylinder.
Ineffective brake – lever/pedal travel normal.	Distorted or glazed rotor.	Replace rotor.
	Distorted, glazed or contaminated brake pads.	Replace pads.
Brake pads drag on rotor – will not retract.	Cup in master cylinder not uncovering relief port.	Inspect master cylinder.
	Rear brake pedal linkage out of adjustment.	Adjust linkage.

GENERAL

See [Figure 2-51](#). The rear suspension preload and compression and rebound damping are controlled by a non-adjustable shock absorber.

NOTE

Rear shock absorber contains no user serviceable parts.

REMOVAL

1. Lift rear wheel off ground using REAR WHEEL SUPPORT STAND (Part No. B-41174)
2. See [2.29 SEAT](#). Remove seat.
3. Attach lifting straps to motorcycle. Insert lifting straps under frame tubes.
4. Attach lifting straps to a floor hoist placed behind the motorcycle. Raise motorcycle off lift until rear suspension is unloaded.
5. See [Figure 2-51](#). Remove bolt (1) and nut (4) on top mount.
6. While supporting the shock absorber, remove the bolt (1) and nut (4) from the bottom mount.
7. Remove shock absorber assembly.

INSTALLATION

1. See [Figure 2-51](#). Place **new** damper bushings (2) into mounting holes of shock absorber (if not installed).
2. See [Figure 2-51](#). Loosely install bottom bolt and nut.
3. Loosely install top bolt and nut.

NOTE

Torque bolts and nuts from the bolt side only.

4. Tighten bottom bolt to 35-40 ft- lbs (47-54 Nm).
5. Tighten top bolt to 35-40 ft- lbs (47-54 Nm).

WARNING

After installing seat, pull upward on front of seat to be sure it is locked in position. If seat is loose, it could shift during vehicle operation causing loss of control of vehicle and death or serious injury.

6. See [2.29 SEAT](#). Remove lifting straps and install seat.

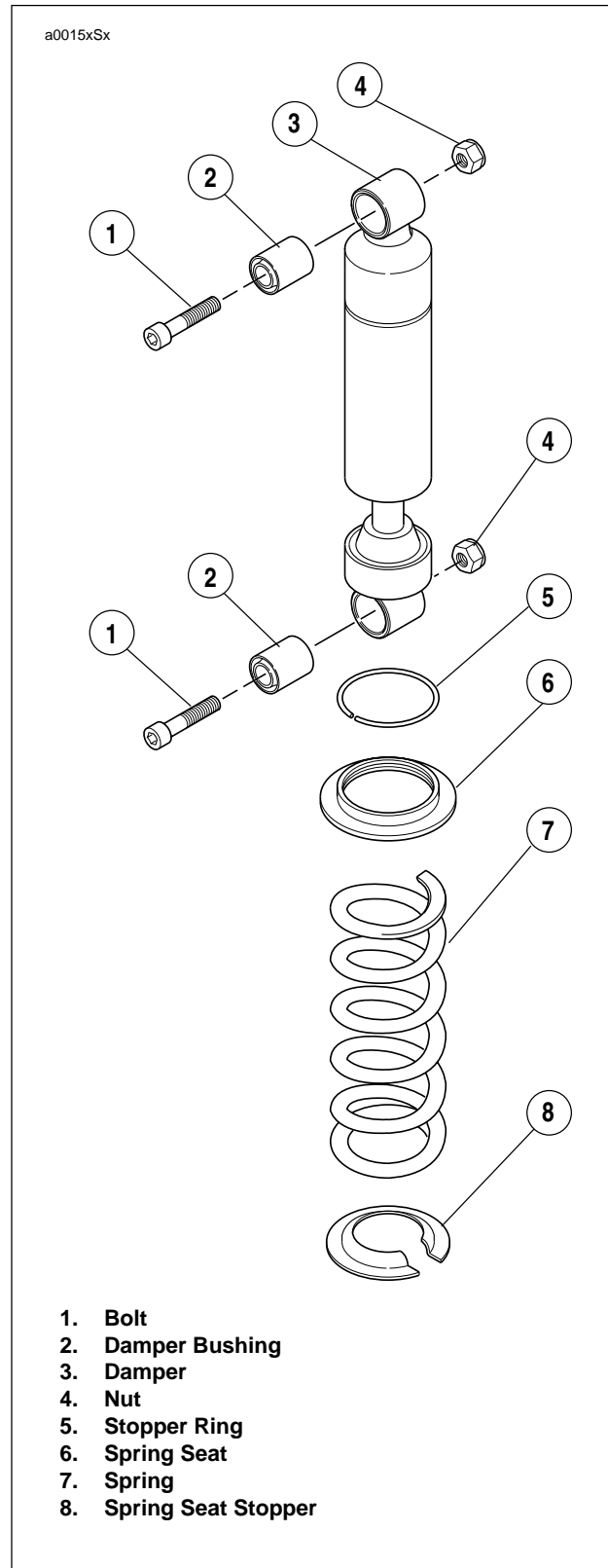

Figure 2-51. Rear Shock Absorber Assembly

REMOVAL/DISASSEMBLY

1. See [Figure 2-52](#). Slide rubber boot off the cable adjusters. Loosen cable adjuster lock on each adjuster.
2. Remove two screws on front housing. Separate housings from handlebar.
3. Remove cables from notches in housings.
4. Unhook ferrules from cable wheel.
5. Remove fuel tank assembly. See [4.2 FUEL TANK COVER/FUEL TANK](#).
6. Cut cable ties along frame.
7. Remove throttle cable clamp.
8. Remove cables from throttle.
9. Carefully note the routing of the cables through/around the forks, along the frame backbone and front/rear of handlebars. Pull cables toward the rear.

CLEANING AND INSPECTION

Clean all parts in a non-flammable cleaning solvent. Blow dry with compressed air. Replace cables if frayed, kinked or bent.

ASSEMBLY/INSTALLATION

1. Route cables as noted in step 10.
2. Connect cables at carburetor.
3. Attach throttle cable clamp. Use LOCTITE THREAD-LOCKER 222 (purple) on screw.
4. Position ferrules on cable wheel.
5. Insert idle control into front switch housing.
6. Slide switch housing over throttle.
7. Insert throttle cable into front switch housing.
8. Attach rear switch housing and position housings on right handlebar by engaging locating pin on front housing with hole in handlebar. Attach housings with two screws, installing longer screw on bottom. Tighten to 12-17 in-lbs (1.4-1.9 Nm).
9. Adjust cables. See [1.18 THROTTLE CABLES](#).
10. Install fuel tank. See [4.2 FUEL TANK COVER/FUEL TANK](#).

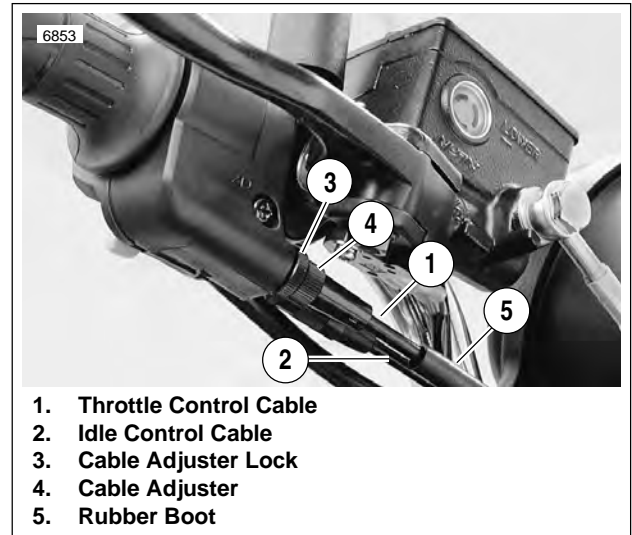

Figure 2-52. Throttle Control Cables

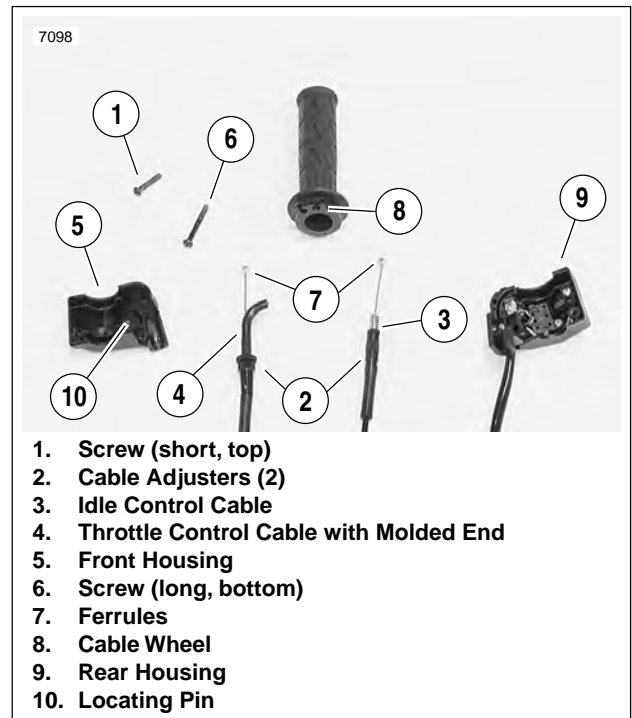

Figure 2-53. Cable Connections

NOTES

GENERAL

See Figure 2-54. The front fork consists of two telescoping outer tube/inner slider assemblies. Each assembly has an internal compression spring which supports the forward

weight of the vehicle and rider. The compression spring extends and retracts to cushion the ride over rough or irregular road surfaces. An oil filled damping mechanism controls the telescoping action of each tube/slider assembly.

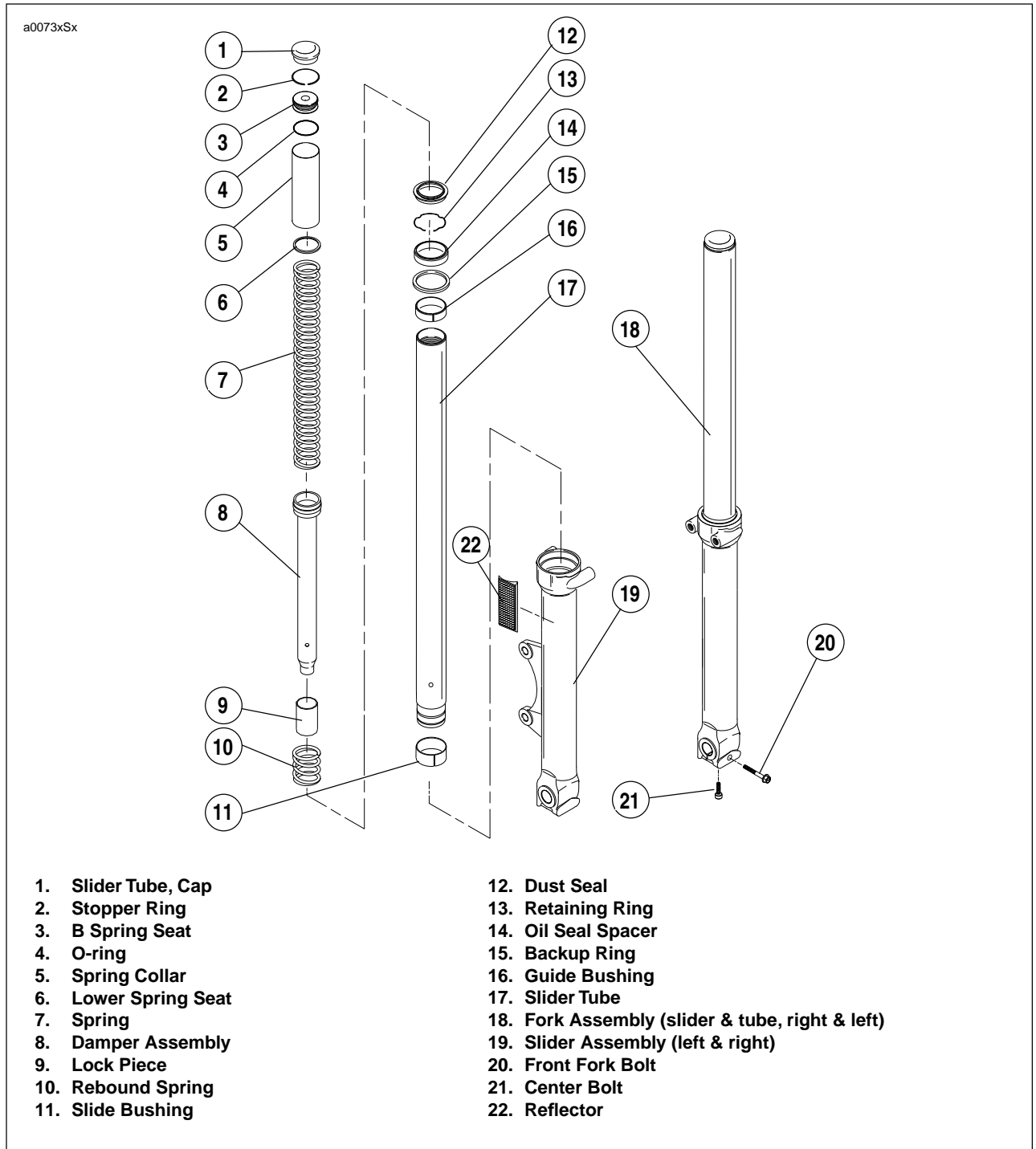

Figure 2-54. Front Fork Assembly

FRONT FORK REMOVAL

1. Raise front wheel off floor.
2. Detach front brake caliper from rotor. See [2.12 FRONT BRAKE CALIPER](#).
3. Remove front wheel. See [2.6 FRONT WHEEL](#).
4. Remove front fender. See [2.24 FENDERS](#).
5. See [Figure 2-55](#). Loosen head lamp bracket screws.

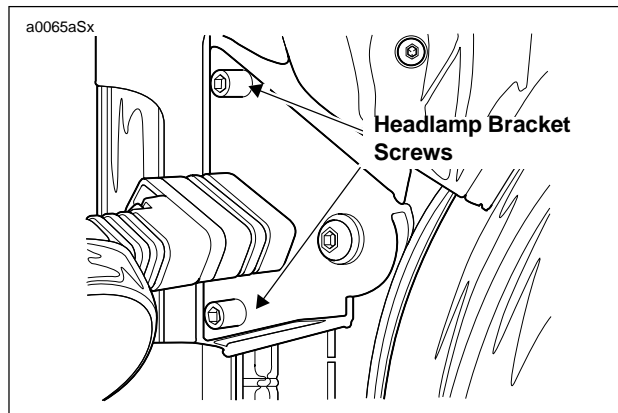

Figure 2-55. Headlamp Brackets

6. See [Figure 2-56](#). Loosen the large pinch screws on both the upper and lower triple clamps.

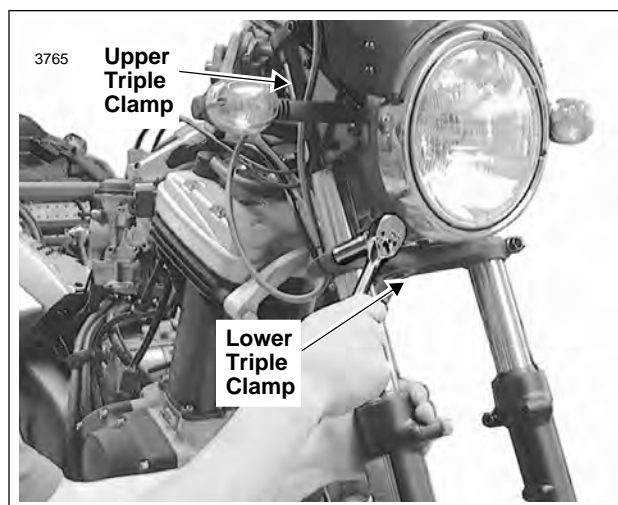

Figure 2-56. Pinch Screws

7. See [Figure 2-57](#). Remove front fork. Repeat procedure for the other front fork.



Figure 2-57. Front Fork Removal

FRONT FORK DISASSEMBLY

1. Remove front forks.
2. See [Figure 2-58](#). Clamp the fork in a vise with front fork holding tool (part no. B-4177).



Figure 2-58. Clamping the Fork

3. See [Figure 2-59](#). Remove slider tube cap.



Figure 2-59. Slider Tube Cap

4. See [Figure 2-60](#). Push down on the B-spring seat (O-ring included) and remove the stopper ring and spring seat.



Figure 2-60. B-Spring Seat

5. See [Figure 2-54](#). See [Figure 2-61](#). Remove the spring collar, lower spring seat and spring from slider tube.

6. See Figure 2-62. Remove the fork oil by pumping the fork leg and rod 8-10 times until the rod moves freely.



Figure 2-62. Pumping Fork Oil

7. See Figure 2-63. Remove the center bolt (metric) from the bottom of the fork tube.



Figure 2-63. Removing Center Bolt

8. See Figure 2-64. Remove the damper assembly, lock piece and the rebound spring from the slider tube.

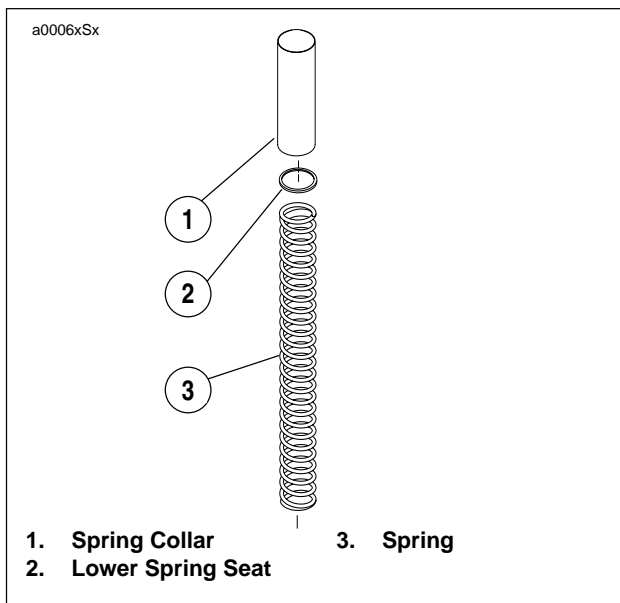

Figure 2-61. Removing Sub-Assembly

CAUTION

Do not to scratch the slide pipe or the outer tube. Scratched tubes may leak fork oil and then must be replaced.

9. See [Figure 2-65](#). Remove the dust seal and the retaining ring from the slider tube.



Figure 2-64. Removing Damper

10. See [Figure 2-66](#). Pull the slider tube out of the slider assembly. Remove oil seal, back-up ring and guide bushing.



Figure 2-65. Removing Dust Seal

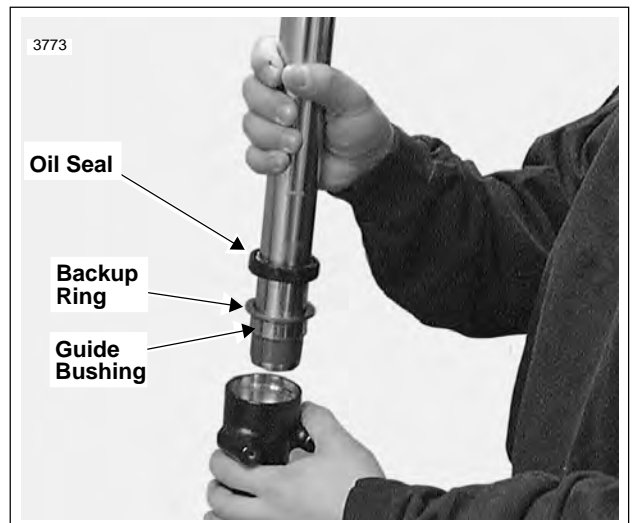

Figure 2-66. Removing Slider Tube

11. See [Figure 2-67](#). Remove the slide bushing by prying the slide bushing at the split.

CLEANING AND INSPECTION

1. Thoroughly clean and inspect all parts. Replace any parts that are bent, broken or damaged.
2. See [Figure 2-68](#). Check the slider tube for score marks, scratches and excessive or abnormal wear. Replace if worn or damaged.
3. Check the slide bushing and the guide bushing for excessive wear or scratches. Replace if damaged or worn.
4. Replace the retaining ring if distorted.
5. Measure spring free length. Replace springs shorter than service wear limit of 12.8 in. (325 mm).
6. Measure rebound spring free length. Replace springs shorter than service wear limit of .69 in. (17.4 mm).
7. See [Figure 2-69](#). Measure slide pipe runout. Replace pipe if runout exceeds the service wear limit of 0.008 in. (0.2 mm).



Figure 2-67. Removing Slide Bushing

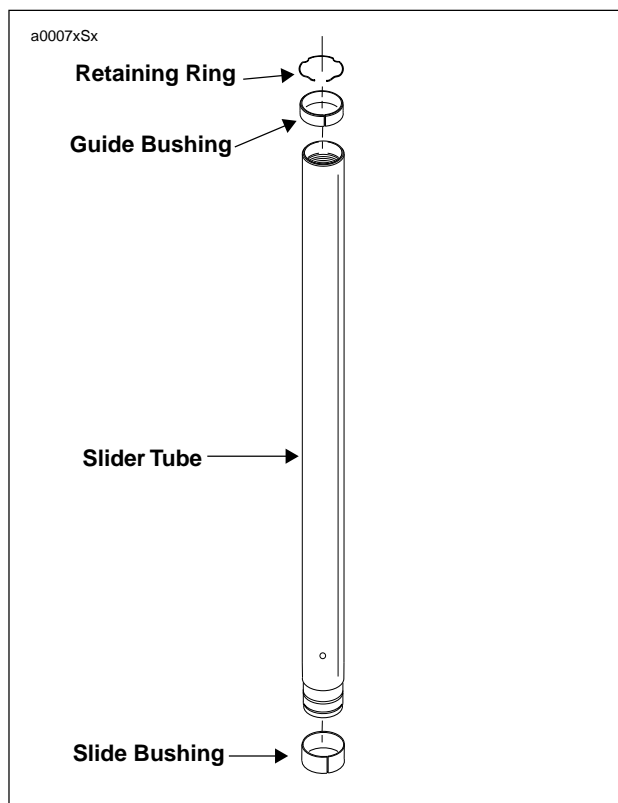

Figure 2-68. Slider tube Components

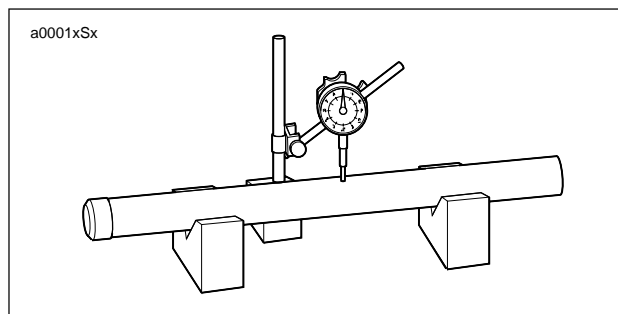

Figure 2-69. Pipe Runout

FRONT FORK ASSEMBLY

1. Coat the slide bushing with fork oil or sealing grease.
2. See [Figure 2-70](#). Install slide bushing onto the slide pipe.



Figure 2-70. Install Slide Bushing

3. See [Figure 2-71](#). Install damper assembly and rebound spring into slider tube.



Figure 2-71. Damper Assembly

4. See [Figure 2-72](#). Install lock piece into damper



Figure 2-72. Lock Piece

5. See [Figure 2-73](#). Clamp the slider assembly in a vise with front fork holding tool (part no. B-4177).



Figure 2-73. Clamping the Slider Assembly

6. See [Figure 2-74](#). Install slider tube into slider assembly.

CAUTION

The outer tube can move freely up and down on the slide pipe. Always hold both the slide pipe and outer tube to prevent damage to bushings and seals.



Figure 2-74. Slider Tube

7. See [Figure 2-75](#). Install spring onto damper assembly.

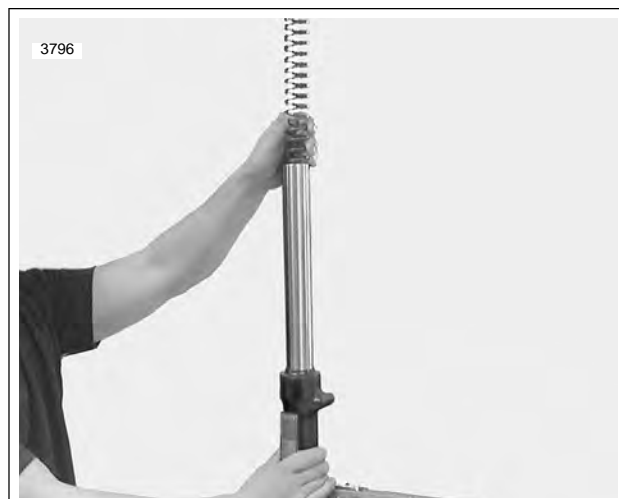

Figure 2-75. Install Rebound Spring

8. See [Figure 2-76](#). Install center bolt and washer.

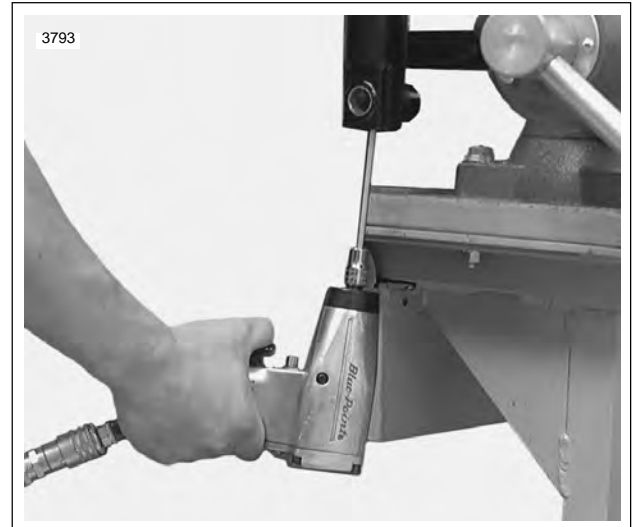

Figure 2-76. Install Center Bolt

9. Coat the guide bushing with fork oil or sealing grease.
10. See [Figure 2-77](#). Install guide bushing onto the slide pipe.



Figure 2-77. Install Guide Bushing

11. See [Figure 2-78](#). Wrap the end of the slide pipe and the slide bushing channel with tape to avoid damaging the oil seal lip when installing.



Figure 2-78. Slider Tube Protection

12. Coat dust seal, oil seal spacer, and backup ring with fork oil or sealing grease.
13. See [Figure 2-79](#). Install oil seal spacer and backup ring.



Figure 2-79. Oil Seal and Backup Ring

14. See [Figure 2-80](#). Using FORK SEAL DRIVER (Part No. B-43991), drive the guide bushing with the oil seal spacer and oil seal into position in the slider assembly.



Figure 2-80. Fork Seal Driver

15. See [Figure 2-81](#). Install retaining ring. Verify ring is under groove inside slider assembly.

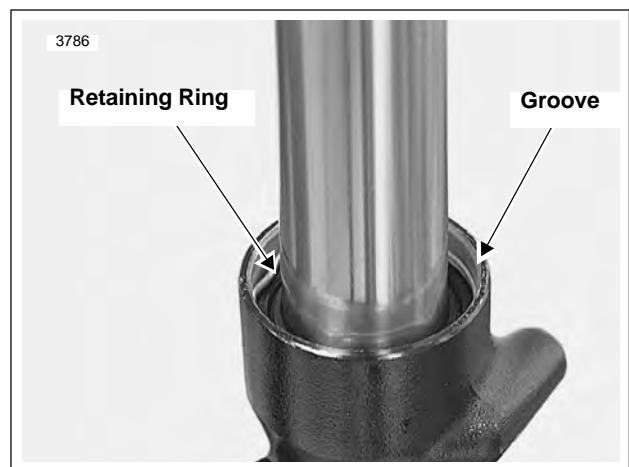

Figure 2-81. Install New Retaining Ring

16. See [Figure 2-82](#). Install new dust seal onto slide pipe.

17. See Figure 2-83. Remove the tape from the slide pipe end.

NOTE

The recommended fork oil is hydraulic fork oil type "E".

18. Pour 9.2 oz. fork oil into fork.
 19. Install lower spring seat and spring collar.
 20. Coat a new O-ring with fork oil or sealing grease.
 21. Install new O-ring onto spring seat.
-
22. See Figure 2-84. Push down on spring seat past groove to install stopper ring. Stopper ring will lock into groove when installed correctly.



Figure 2-82. Install New Dust Seal

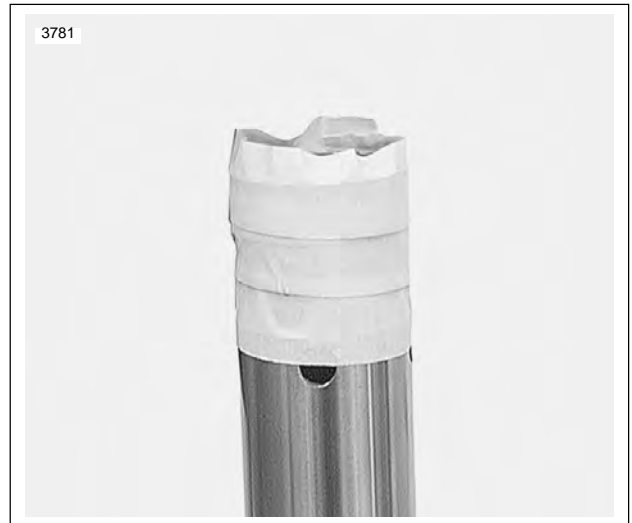

Figure 2-83. Remove Slider Tube Protection



Figure 2-84. Compressing Spring Seat

23. See Figure 2-85. Install slider tube cap.



Figure 2-85. Slider Tube Cap

FRONT FORK INSTALLATION

1. See Figure 2-86. Install fork tubes through upper and lower triple clamps.

NOTE

When installing the front forks, use a screwdriver to pry apart the triple clamps.

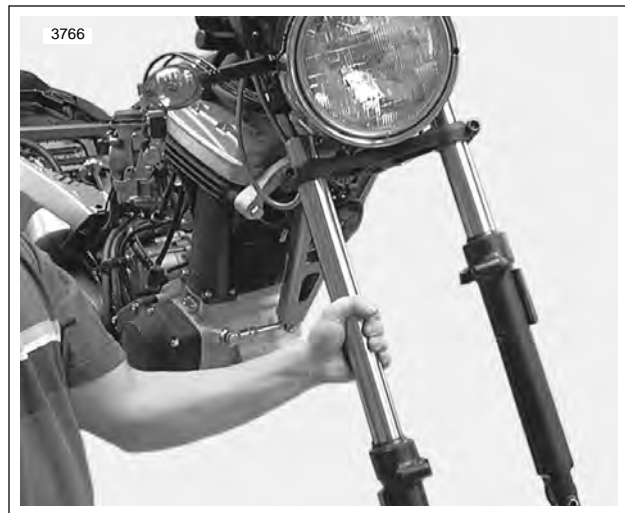

Figure 2-86. Installing Fork Tube

2. See Figure 2-87. Apply LOCTITE ANTI-SEIZE to the threads of triple clamp pinch screws.

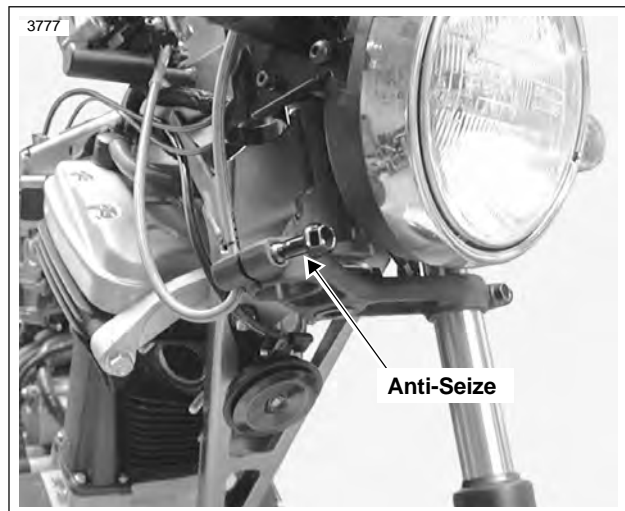

Figure 2-87. Triple Clamp Pinch Screw

3. See Figure 2-88. Align and secure fork tubes.

- a. Position fork tubes so that top of each slider tube is flush with the top surface of upper triple clamp. Be sure that top surface of fork is not below top surface of upper triple clamp.
 - b. Tighten upper triple clamp pinch screws (at sliders) to 13-16 ft-lbs (17.6-21.7 Nm).
 - c. Tighten lower triple clamp pinch screws to 22-29 ft-lbs (30-39 Nm).
 - d. See [Figure 2-89](#). Tighten head lamp brackets flush against bottom of top triple clamp.
4. Install front fender. See [2.24 FENDERS](#).
 5. Install front wheel. See [2.6 FRONT WHEEL](#).
 6. Install front brake caliper. See [2.12 FRONT BRAKE CALIPER](#).
 7. Align head lamp. See [7.17 HEADLAMP](#).

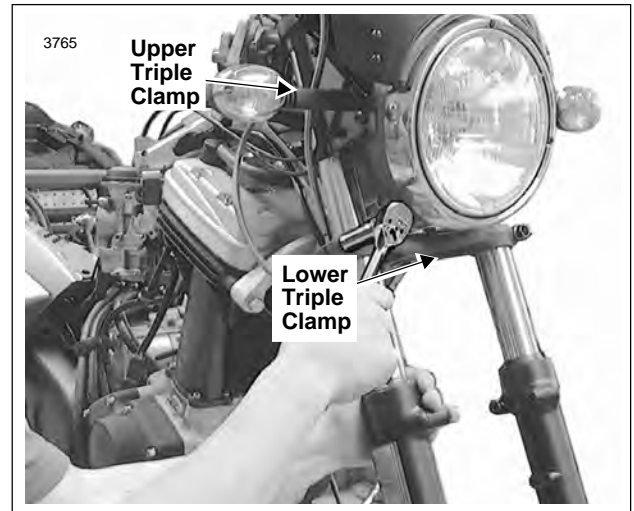

Figure 2-88. Pinch Screws

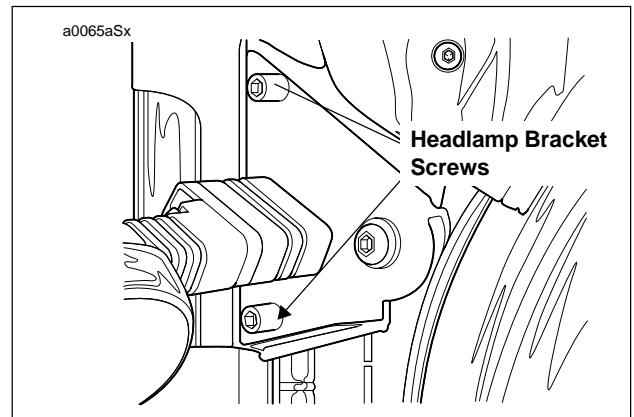

Figure 2-89. Tighten Head lamp Bracket

REMOVAL/DISASSEMBLY

1. Remove seat. See 2.29 SEAT.
2. Disconnect battery.

WARNING

To protect against shock and accidental start-up of vehicle, disconnect the negative battery cable before proceeding. Inadequate safety precautions could result in death or serious injury.

3. Remove dash. See 2.28 INSTRUMENT PANEL.
4. Remove handlebars. See 2.31 HANDLEBARS.
5. Remove fork assembly. See 2.18 FRONT FORK.
6. Remove ignition switch assembly. See 7.6 IGNITION/ HEADLAMP KEY SWITCH.
7. See Figure 2-90. Remove screw (9) and capnut (4).
8. Support lower triple clamp (6) and remove upper triple clamp (5).
9. Remove upper dust shield (3) and upper bearing (1).
10. Lower triple clamp can be removed.
11. Remove lower bearing (1) and lower dust shield (3) from lower triple clamp.

CLEANING AND INSPECTION

1. See Figure 2-90. Clean the dust shields (3), bearing cups (2), fork stem and lower triple clamp (6) and frame with solvent.
2. Carefully inspect bearing races and assemblies for pitting, scoring, wear and other damage. Replace damaged bearings (1) as a set (1, 2 and 3).
3. Check the fork stem and lower triple clamp (6) for damage. Replace if necessary.

ASSEMBLY/INSTALLATION

1. If removed, install **new** bearing cups into frame steering head using STEERING HEAD BEARING RACE INSTALLER (Part No. HD-39302).
2. Liberally coat the bearing cones (1) with grease using WHEEL BEARING PACKER TOOL (Part No. HD-33067). Work the grease into the rollers.
3. Install lower bearing.
 - a. Place lower bearing dust shield (3) over fork stem.
 - b. Find a section of pipe having an inside diameter slightly larger than the outside diameter of the fork stem.
 - c. Press bearing (1) with small end up onto fork stem and lower triple clamp (6). Use the pipe as a press-on tool.
4. Insert lower triple clamp (6) through the steering head. Install the upper bearing (1) with small end down and dust shield (3) onto fork stem.

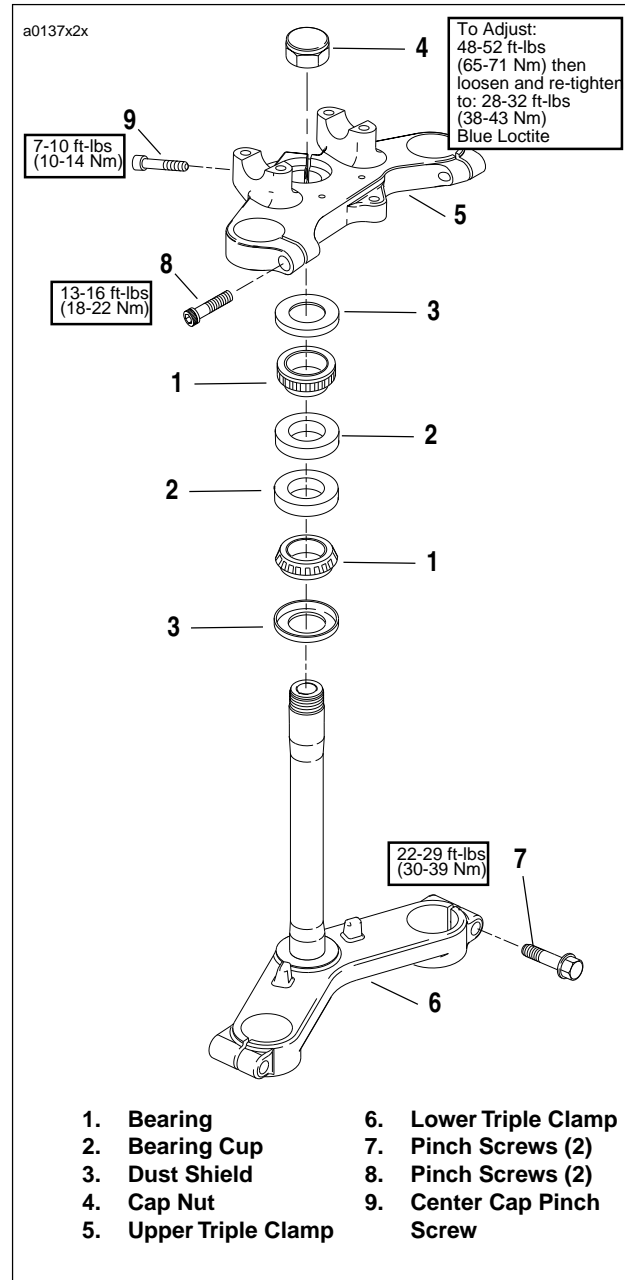

Figure 2-90. Fork Stem and Bracket Assembly

5. Apply LOCTITE THREADLOCKER 243 (Blue) to fork stem. Loosely install upper triple clamp (5) using cap nut (4).
6. Install fork assemblies. See 2.18 FRONT FORK.
7. Tighten cap nut (4) until the bearings have no free play. Make sure the fork stem turns freely, then tighten the fork stem clamp screw (9).
8. Check steering head bearing adjustment.
9. Install handlebars. See 2.31 HANDLEBARS.
10. Install dash. See 2.28 INSTRUMENT PANEL.
11. Connect battery negative cable.
12. Install seat. See 2.29 SEAT.

WARNING

After installing seat, pull upward on front of seat to be sure it is locked in position. If seat is loose, it could shift during vehicle operation, causing loss of control of vehicle and death or serious injury.

INSPECTION

Check steering head bearings:

- At the 1000 mile (1600 km) service interval.
 - At every 2500 mile (4000 km) service interval thereafter.
 - When storing or removing the motorcycle for the season.
 - Lubricate and adjust at every 20,000 mile (32,000 km) service interval.
1. Detach clutch cable at handlebar.
 2. Remove seat and fuel tank. See [4.2 FUEL TANK COVER/FUEL TANK](#).
 3. Attach lifting straps to frame tube behind steering neck. Raise front wheel off floor using a floor hoist and lifting straps.
 4. Turn front wheel to full right lock.
 5. See [Figure 2-91](#). Attach a spring scale into the hole in the front axle. With scale 90 degrees from fork leg, pull front wheel to center position. It should take **6.5-7 lbs (2.9-3.2 kg)** to pull front wheel to center.
 6. Attach clutch cable to handlebar.

WARNING

After installing seat, pull upward on front of seat to be sure it is locked in position. If seat is loose, it could shift during vehicle operation, causing loss of control of vehicle and death or serious injury.

7. Install seat and fuel tank. See [4.2 FUEL TANK COVER/FUEL TANK](#).

NOTE

Check that clutch and throttle cables do not bind when measuring bearing resistance.

Lubrication

At 10,000 miles (16,100 km) and every 10,000 miles (16,100 km) thereafter, lubricate the steering head bearings with [WHEEL BEARING GREASE \(Part No. 99855-89\)](#).

ADJUSTMENT

1. Detach clutch cable at handlebar.
2. Remove seat and fuel tank. See [4.2 FUEL TANK COVER/FUEL TANK](#).
3. Attach lifting straps to frame backbone behind steering neck. Raise front wheel off floor using a floor hoist and lifting straps.
4. Turn front wheel to full right lock.
5. See [Figure 2-91](#). Attach a spring scale into the hole in the front axle. Pull front wheel to center position. It



Figure 2-91. Steering Head Bearing Check

should take **6.5-7 lbs (2.9-3.2 kg)** to pull front wheel to center.

6. See [Figure 2-90](#). To adjust:
 - a. Loosen both pinch screws (7) on lower triple clamp.
 - b. Loosen center cap pinch screw (9) on upper triple clamp.
 - c. Loosen cap nut (1), then tighten to 48-52 ft-lbs (65-71 Nm) to seat bearing. Loosen cap nut, apply **LOCTITE THREADLOCKER 243 (Blue)** to threads of fork stem and retighten cap nut to 28-32 ft-lbs (38-43 Nm).
7. Recheck tension using spring scale. See Step 5.
8. Tighten both lower triple clamp pinch screws (7) to 22-29 ft-lbs (30-39 Nm).
9. Tighten center cap pinch screw to 7-10 ft-lbs (10-14 Nm).

WARNING

After installing seat, pull upward on front of seat to be sure it is locked in position. If seat is loose, it could shift during vehicle operation, causing loss of control of vehicle and death or serious injury.

10. Install seat and fuel tank. See [4.2 FUEL TANK COVER/FUEL TANK](#).

REMOVAL

1. Remove seat. See 2.29 SEAT.
2. Remove battery. See 7.16 BATTERY.

⚠ WARNING

Always disconnect the negative battery cable first. If the positive battery cable should contact ground with the negative cable installed, the resulting sparks may cause a battery explosion which could result in death or serious personal injury.

3. Remove right side footpeg support bracket. See 2.22 FOOTPEGS AND FOOTPEG SUPPORT BRACKETS.
4. Remove three bolts holding front sprocket cover. See 2.23 SPROCKET COVER.
5. Remove inner fender. See 2.24 FENDERS.
6. Remove lower belt guard. See 2.25 LOWER BELT GUARD.
7. Remove rear axle nut, axle, spacers and brake with carrier. See 2.7 REAR WHEEL.
8. Remove drive belt. See 1.11 DRIVE BELT AND REAR SPROCKET
9. Remove rear wheel. See 2.7 REAR WHEEL.
10. Remove lower rear shock fastener. See 2.16 REAR SHOCK ABSORBER.
11. See Figure 2-92. Loosen swing arm pinch bolt (1).
12. Remove swingarm pivot bolt (6) and swingarm.
13. Remove well nuts from swingarm.
14. Use slide hammer (SNAP-ON Part No. CJ1275 or equivalent) and bearing remover to remove bearings (4).
15. Remove swingarm spacer (5).

INSTALLATION

1. See Figure 2-92. Install new bearings (4) and spacer (5).
2. Position swing arm in mounting block. Apply anti-sieze to swingarm bolt (6) and install. Torque to 24-26 ft-lbs (32.5-35.2 Nm).
3. Apply LOCTITE 243 BLUE to pinch bolt (1) and install. Torque to 18-20 ft-lbs (24.4-27.1 Nm).
4. Install well nuts.
5. Install rear shock and fastener. Torque to 35-40 ft-lbs (47.5-54.2 Nm).
6. Install rear wheel, axle, brakes, and spacers. Torque rear axle nut to 48-52 ft-lbs (65.1-70.5 Nm).

⚠ WARNING

After completing repairs or bleeding the system, always test motorcycle brakes at low speed. If brakes are not operating properly or braking efficiency is poor, testing at high speeds could result in death or serious injury.

7. Install drive belt.
8. Install rear fender, lower belt guard, and sprocket cover.

9. Loosely install right side footpegs mount.
10. Install reservoir, master cylinder, and brake pedal. Tighten brake pedal bolt to 6-8 ft-lbs (8-11 Nm).
11. Tighten footpeg mounting bracket.
12. Install battery. See 7.16 BATTERY.

⚠ WARNING

Always connect positive battery cable first. If the positive cable should contact ground with the negative cable installed, the resulting sparks may cause a battery explosion which could result in death or serious injury.

13. Install seat. See 2.29 SEAT

⚠ WARNING

After installing seat, pull upward on front of seat to be sure it is locked in position. If seat is loose, it could shift during vehicle operation, causing loss of control of vehicle and death or serious injury.

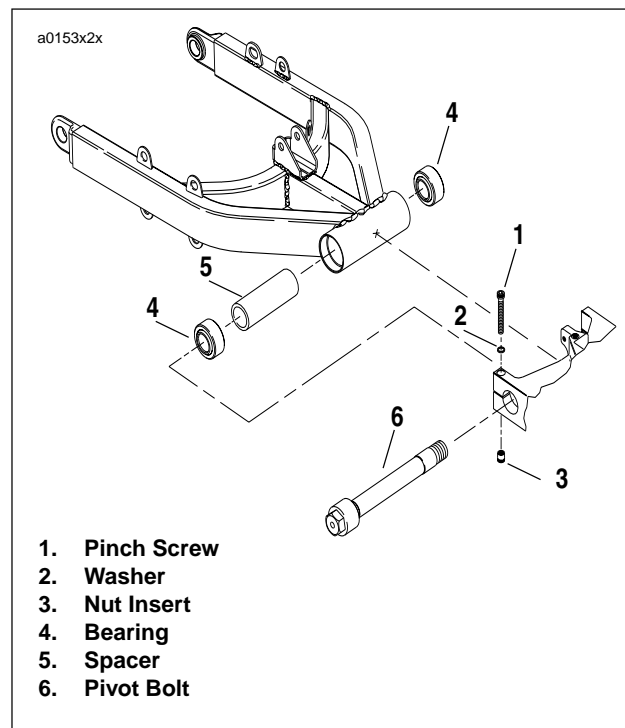

Figure 2-92. Swingarm

GENERAL

See Figure 2-90 for exhaust system assembly.

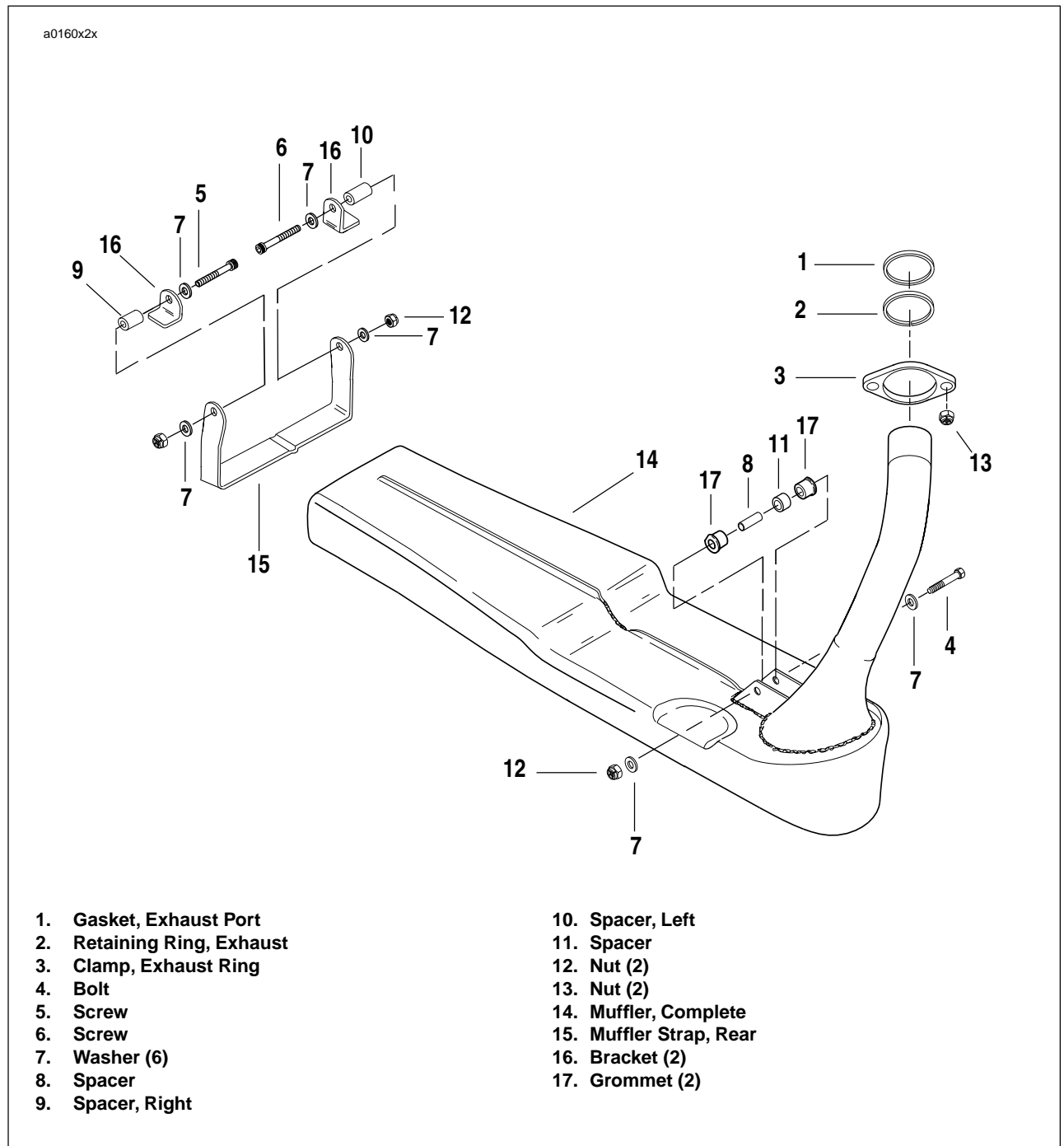

Figure 2-93. Exhaust System Assembly

MUFFLER REMOVAL

CAUTION

To prevent damage to muffler, secure muffler before removing rear muffler strap.

1. See Figure 2-93. Remove fasteners, washers, spacers and brackets on rear muffler strap.
2. Remove exhaust header fasteners (13).
3. Remove front muffler mounting fastener, nut, and washer (4, 7, 12).
4. Remove exhaust header.
5. Remove retaining ring (2).
6. Remove exhaust header clamp (3).
7. Remove and discard exhaust port gasket (1).

MUFFLER INSTALLATION

1. See Figure 2-93. Install new bushings and spacer onto front muffler support hole (8, 17, 11).
2. Install header clamp onto exhaust (3).
3. Install retaining ring oriented 90° from exhaust studs (2).

NOTE

Retaining ring may crack if not oriented as stated in step 3.

4. Install new exhaust port gasket (1).
5. Position muffler on motor. Hand tighten nuts (13).
6. Slide muffler over bushings on front mount.
7. Hand thread bolt washer and nut to front muffler support.
8. Install rear muffler strap(15).

NOTE

A rubber mallet may be used to tap the muffler strap into muffler notches.

9. Install right side muffler spacers (9), brackets (16) and fasteners (5).
10. Install left side muffler spacers, brackets and fasteners.
11. Hand tighten fasteners on rear muffler strap bolts (5,6).
12. Tighten lower, then upper header nuts to 6-8 ft-lbs (8.1-10.8 Nm).
13. Tighten rear strap bolts (5, 6) to 22-25 ft lbs (30-34 Nm).
14. Tighten front muffler bolts (4) to 22-25 ft lbs (30-34 Nm).

CAUTION

Use care when performing service procedures and avoid scratching the frame and/or painted parts. Failure to do so may result in corrosion of parts.

REMOVAL

Footpeg

1. See [Figure 2-94](#). Remove cotter pin (3).
2. Remove clevis pin (4).
3. Remove spacer (7, rear peg only).
4. Remove footpeg.

Footpeg Support Bracket

1. Remove seat. See [2.29 SEAT](#).
2. See [Figure 2-95](#). On left side remove oil tank drain hose, breather drain hose, p-clamp and fastener.
3. On right side remove rear master cylinder, spacers, reservoir, and brake pedal.
4. See [Figure 2-94](#). Remove mounting bolts located behind footpeg support bracket.
5. Remove footpeg support bracket.

INSTALLATION

Footpeg Support Bracket

1. Align footpeg support mounting bracket and spacer with mounting holes on frame.
2. Install mounting bolts and washers. Tighten fasteners to 25-30 ft-lbs. (34-41 Nm).
3. See [Figure 2-95](#). On left side install p-clamp with oil tank drain hose and breather hose.
4. On right side install rear master cylinder, spacers, reservoir, and brake pedal. See [2.14 REAR BRAKE MASTER CYLINDER](#).
5. Install seat. See [2.29 SEAT](#).

WARNING

After installing seat, pull upward on front of seat to be sure it is locked in position. If seat is loose, it could shift during vehicle operation, causing loss of control of vehicle and death or serious injury.

Footpeg

1. See [Figure 2-94](#). Align footpeg mounting holes with footpeg support bracket mounting holes.
2. Insert dowel pin (and on rear peg, spacer) through mounting holes.
3. Install new cotter pin.

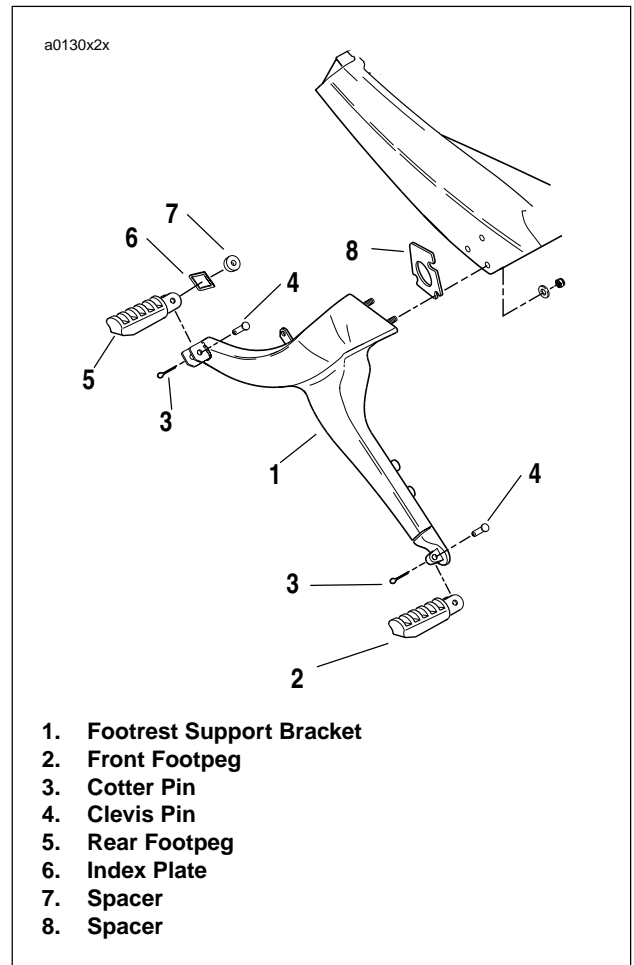

Figure 2-94. Footpeg Support Bracket (Left Side)

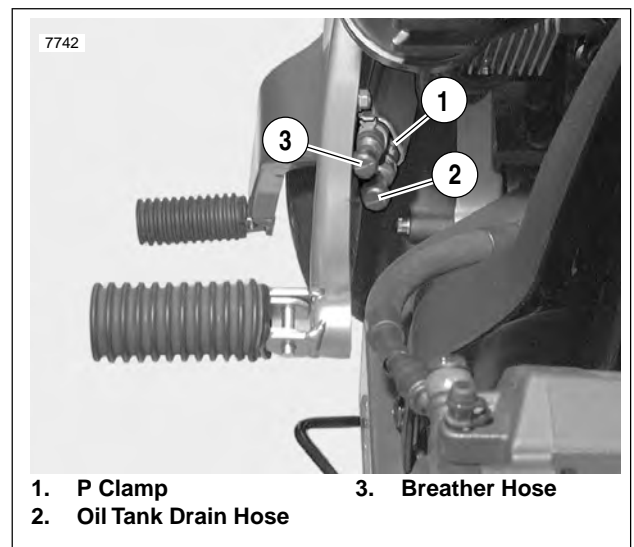

Figure 2-95. Left Side Footpeg Support Bracket

REMOVAL

1. See [Figure 2-96](#). Remove master cylinder bolts and spacers.
2. Remove rear pedal bolt and move pedal assembly down-away from support bracket.
3. See [Figure 2-97](#). Remove the three screws and washers on sprocket cover.
4. Slide cover free.

INSTALLATION

1. Apply LOCTITE THREADLOCKER 243 (Blue) to threads of three screws.
2. Position sprocket cover and install three screws and washers. Tighten fasteners to 30-36 **in-lbs** (3.4-4.1 Nm).
3. Move pedal assembly in position and install pedal bolt. Torque pedal bolt to 6-8 ft-lbs (8-11 Nm).
4. Install master cylinder bolts and spacers. See [2.14 REAR BRAKE MASTER CYLINDER](#).

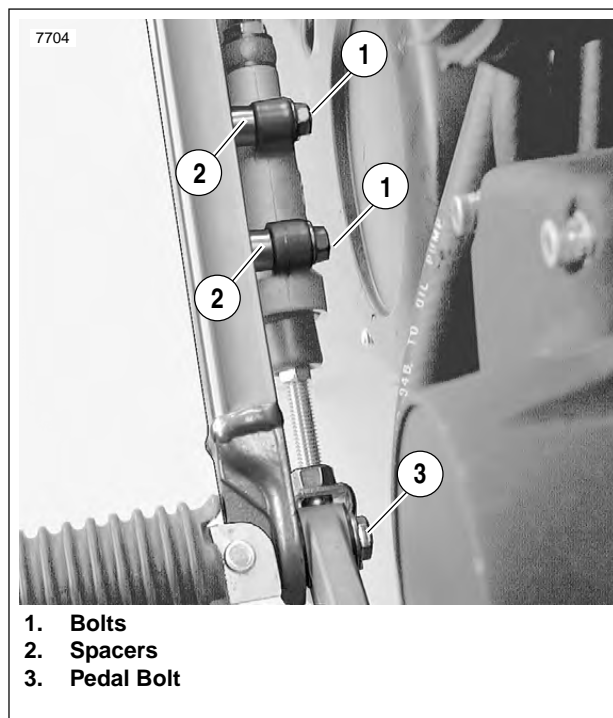

Figure 2-96. Master Cylinder Mounting

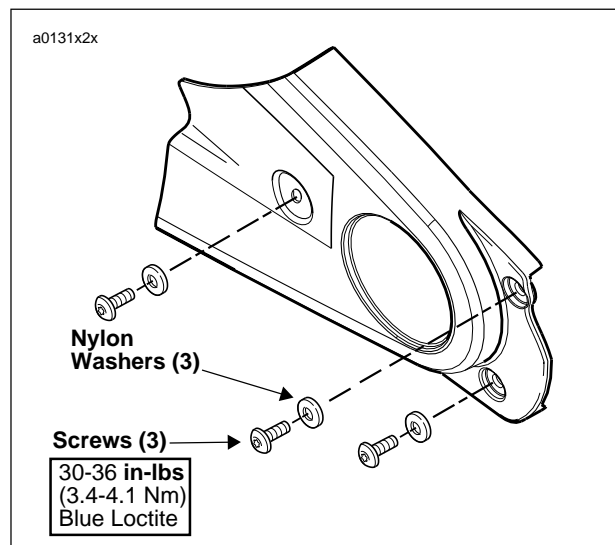

Figure 2-97. Sprocket Cover

FRONT FENDER REMOVAL

1. Raise front wheel off ground.
2. Remove front wheel. See 2.6 FRONT WHEEL.
3. See Figure 2-98. Remove four lower fender mounting screws.
4. See Figure 2-99. Remove front fender.

FRONT FENDER INSTALLATION

1. Raise front wheel off floor.
2. Align front fender mounting holes with front fork bracket.

NOTE:

The longer end of the fender faces away from the front end.

3. Apply LOCTITE THREADLOCKER 243 (Blue) to first few threads of four fender mounting screws.
4. See Figure 2-98. Install front fender with four fender mounting screws.
5. Tighten fender mounting screws to 12-14 in-lbs (1.3-1.6 Nm).

REAR FENDER REMOVAL

1. Remove seat. See 2.29 SEAT.
2. Remove right side footpeg support. See 2.22 FOOTPEGS AND FOOTPEG SUPPORT BRACKETS.
3. See Figure 2-100. Remove rear fender mounting screws and washers from rear fender.
4. Remove rear fender.

REAR FENDER INSTALLATION

1. Position rear fender.
2. Install rear fender mounting screws, washers and well-nuts on rear fender.
3. Tighten rear fender mounting screws to 30-36 in-lbs (3.4-4.1 Nm).
4. Install right side footrest support bracket. See 2.22 FOOTPEGS AND FOOTPEG SUPPORT BRACKETS.
5. Install seat. See 2.29 SEAT.

WARNING

After installing seat, pull upward on front of seat to be sure it is locked in position. If seat is loose, it could shift during vehicle operation, causing loss of control of vehicle and death or serious injury.

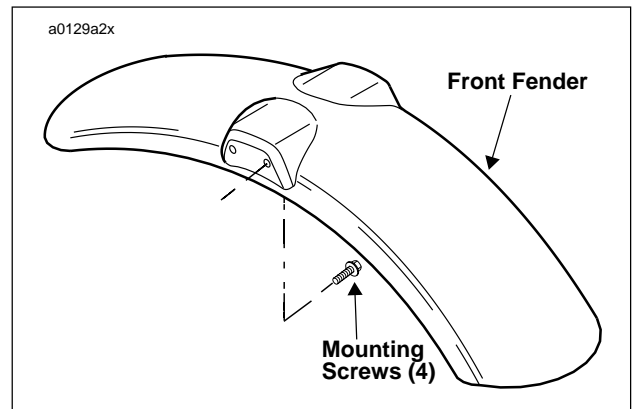

Figure 2-98. Front Fender Assembly



Figure 2-99. Removing Front Fender

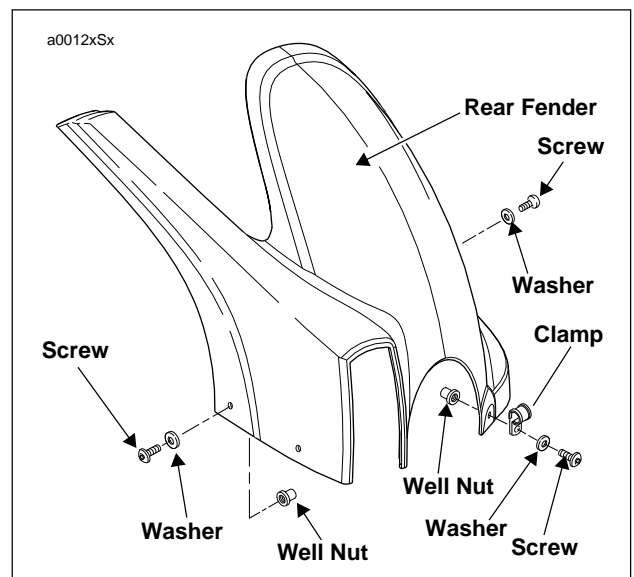

Figure 2-100. Rear Fender Assembly

REMOVAL

1. See [Figure 2-101](#). Remove two screws and nylon washers securing lower belt guard to swingarm.
2. Remove belt guard.

INSTALLATION

1. Position belt guard over tabs on swingarm.
2. Secure belt guard with two screws and nylon washers.
3. Tighten screws to 30-36 **in-lbs** (3.4-4.1 Nm).

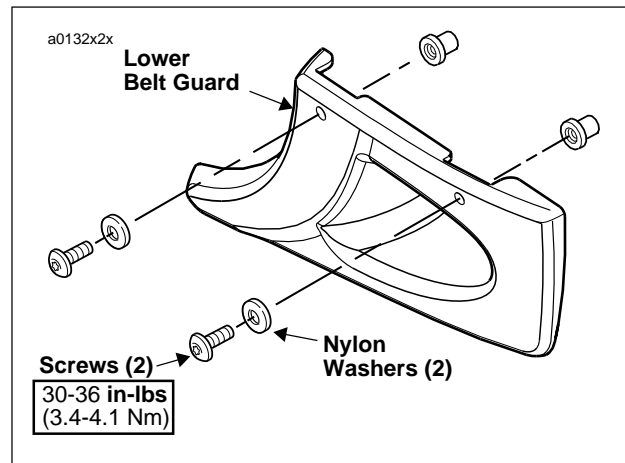

Figure 2-101. Lower Belt Guard

REMOVAL-TAIL SECTION

1. Remove seat. See 2.29 SEAT.
2. See Figure 2-102. Remove fasteners and clamp (3, 20 and 21).
3. Remove tree fasteners (2).
4. Remove tail section (1).

WARNING

To protect against shock and accidental start-up of vehicle, disconnect the negative battery cable before proceeding. Inadequate safety precautions could result in death or serious injury.

5. Disconnect battery negative cable.

6. Unplug taillight.
7. Cut tie wrap holding taillight and turn signal wires.
8. Unplug turn signals.
9. Remove nut (8) and washer (7).
10. Remove turn signals (6).
11. Remove nuts and flat washers from back of taillight.
12. Remove taillight.
13. Remove bolts (4) and nuts (9).
14. Remove license plate bracket (5).

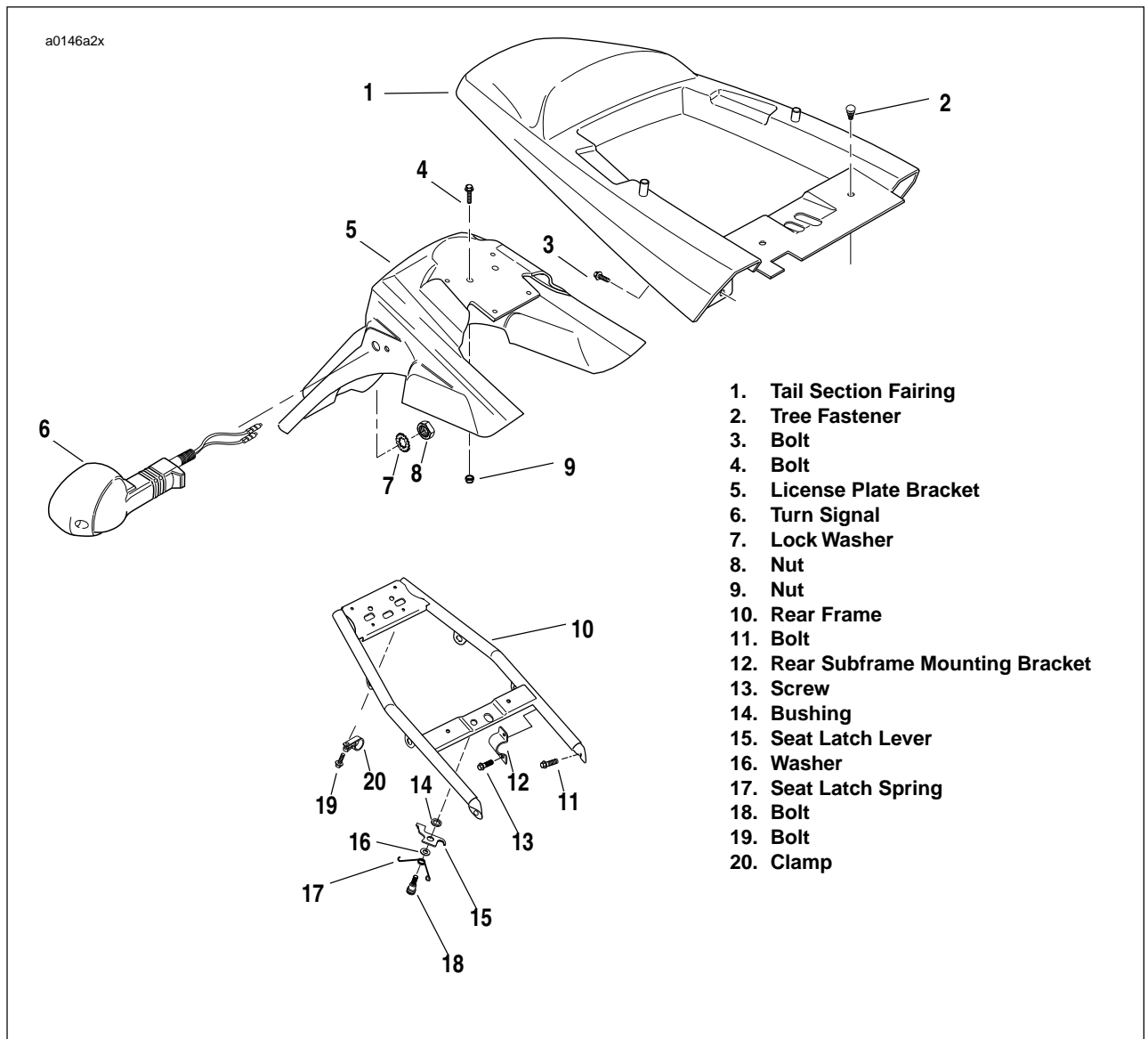

Figure 2-102. Tail Section

REMOVAL - REAR FRAME ASSEMBLY

1. Remove tail section.
2. Disconnect rear wire harness connector [7] (6-place amp), located under seat near fuse block. Detach connector from "T" stud.
3. See [Figure 2-102](#). Remove fasteners (13) and bracket (12).
4. Remove fasteners (11).
5. Slide rear frame assembly (10) out.

INSTALLATION - REAR FRAME ASSEMBLY

1. Slide rear frame assembly (10) into frame.
2. Install fasteners (11).
3. Install brackets (12) and fasteners (13).
4. Connect rear wire harness and mount on "T" stud.

INSTALLATION - TAIL SECTION

1. Install license plate bracket (5) using fasteners (4) and nuts (9) in rear holes.
2. Install taillight using flat washers and nuts.
3. Install turn signals (6) using lock washers (7) and nuts (8).
4. Connect turn signal wires and taillight wires. Cable tie together.
5. Install tail section (1) using fasteners (3, 20, 2).
6. Connect battery negative cable.
7. Install seat. See [2.29 SEAT](#).

WARNING

After installing seat, pull upward on front of seat to be sure it is locked in position. If seat is loose, it could shift during vehicle operation, causing loss of control of vehicle and death or serious injury.

REMOVAL

1. See [Figure 2-103](#). Remove two screws and nylon washers on each side.
2. Remove windscreen.
3. See [Figure 2-104](#). Remove windscreen trim.
4. Remove windscreen mounting brackets.



Figure 2-103. Remove Screws

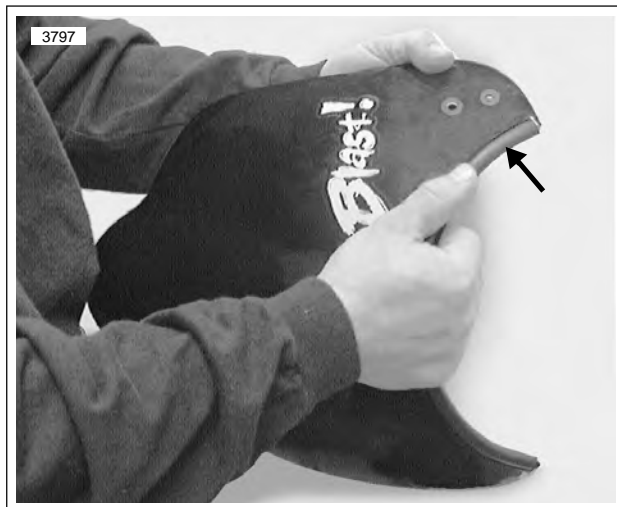

Figure 2-104. Windscreen Trim

INSTALLATION

1. If removed, install both windscreen brackets. See [7.17 HEADLAMP](#).
2. Verify trim is installed on windscreen.
3. Install two screws and nylon washers on each side. Tighten screws to 9-11 **in-lbs** (1 Nm).

REMOVAL

1. See Figure 2-105. Remove two mounting screws and instrument panel.
2. Remove two screws from back of instrument panel.
3. Remove rubber boot and odometer reset switch.
4. Depress tab and remove speedometer connector [39].

NOTE

To remove speedometer, see 7.25 ELECTRONIC SPEED-OMETER.

INSTALLATION

1. Install odometer reset switch to instrument panel and install rubber boot.
2. Install connector [39] on back of speedometer.
3. Apply LOCTITE THREADLOCKER 243 (Blue) to threads of mounting screws. Install dash with two mounting screws. Tighten screws to 30-36 **in-lbs** (3.4-4.1 Nm).

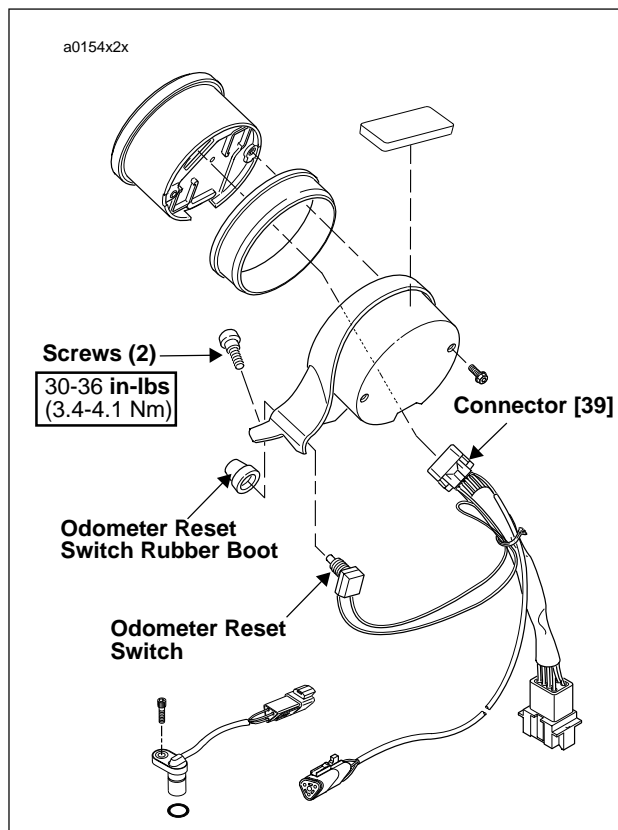

Figure 2-105. Instrument Panel

REMOVAL

CAUTION

Use both hands to release tension on the seat latch to avoid pinching fingers.

You will need to use both hands during this operation to release tension on the seat latch (located beneath the seat).

1. See Figure 2-106. Push or pull the seat latch toward the front of the motorcycle with your thumb.
2. Grasp the rear section of the seat with one hand.
3. Lift seat away from motorcycle to loosen from frame.

INSTALLATION

There are two different seats available for the Blast Model.

1. See Figure 2-107. Locate tab on bottom of seat.
2. See Figure 2-108. Ensure seat is upright. Grasp the rear section of the seat with one hand and grasp the front section of the seat with the other hand.
3. See Figure 2-109. Push seat forward while flexing the rear section of the seat upward until the tongue locks into the bracket located on the frame.
4. Push down firmly on the seat

NOTE

You will hear a click when the locating tab and seat latch, lock together correctly.

5. Ensure seat is locked in position.

WARNING

After installing seat, pull upward on front of seat to be sure it is locked in position. If seat is loose, it could shift during operation of vehicle and result in death or serious injury.

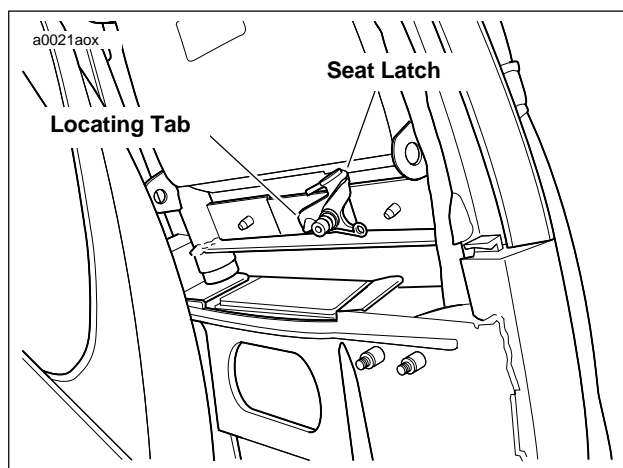

Figure 2-106. Seat Latch

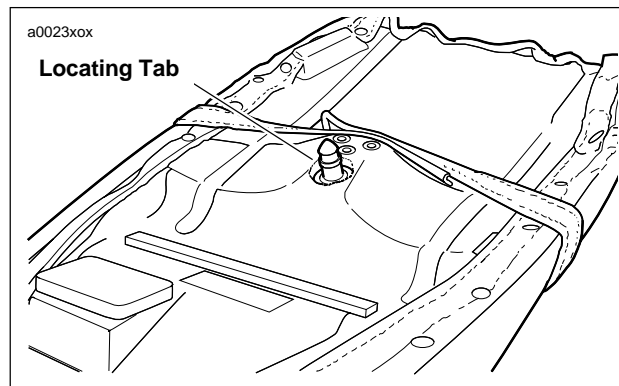

Figure 2-107. Underside View of Seat

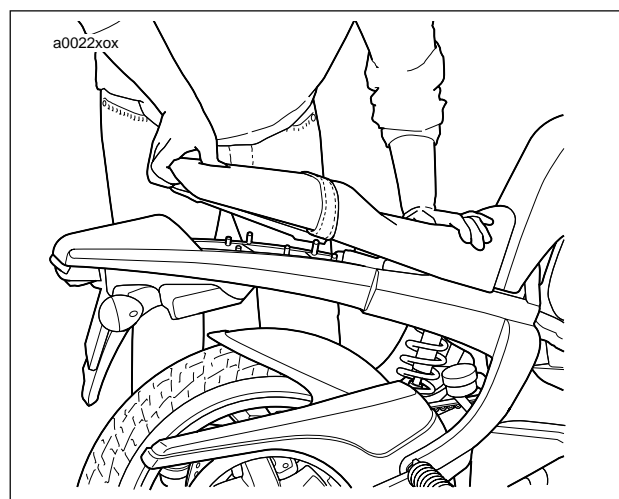

Figure 2-108. Seat Installation

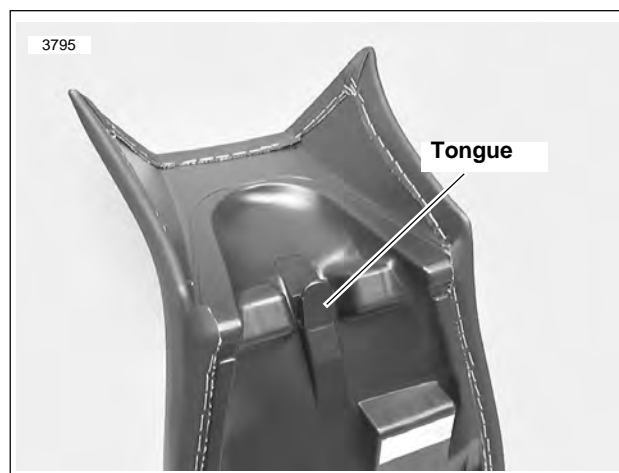

Figure 2-109. Locking Seat Tongue

GENERAL

⚠ WARNING

- If the side stand is not in the full forward position when vehicle weight is rested on it, the vehicle could fall over which could result in death or serious injury.
- Always park motorcycle on a level, firm surface. Vehicle weight could cause motorcycle to fall over, which could result in death or serious injury.

See Figure 2-110. The side stand is located on the left side of the motorcycle. The side stand swings outward to support the motorcycle for parking.

Test the side stand in the following manner. Without vehicle weight resting on it, side stand should move freely into extended (down) and retracted (up) positions.

The side stand activates the side stand switch (4) which is part of the starter interlock system.

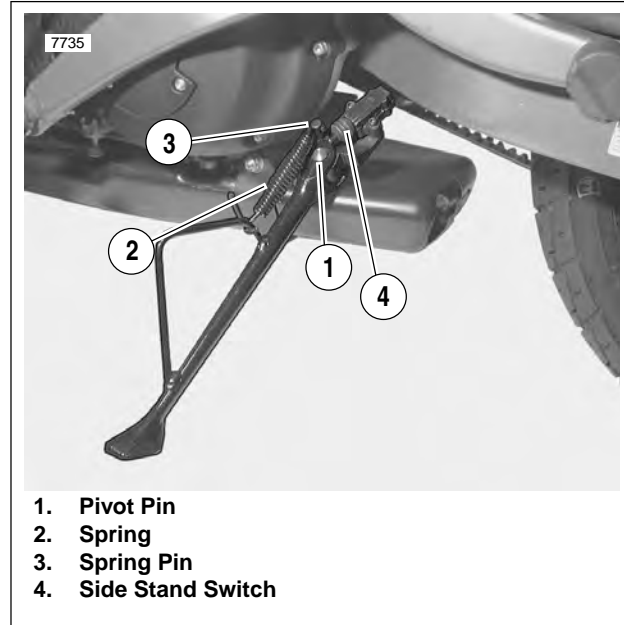

Figure 2-110. Side Stand

INSPECTION

1. Test the side stand with the vehicle upright and level:
 - a. The side stand should move freely into extended down and up position.
2. Check side stand switch operation after first 1000 miles and every 2500 miles.

DISASSEMBLY/REMOVAL

1. Raise rear wheel off floor using REAR WHEEL SUPPORT STAND (Part No. B-41174).
2. Disconnect electrical connection.
 - a. Press Tab indent
 - b. Pull connectors apart.
3. Cut tie wrap from rear brake line.
4. Remove spring (2) from side stand.
5. Remove cotter pin and pivot pin (1).
6. Remove side stand from frame.

ASSEMBLY/INSTALLATION

1. Apply LITHIUM GREASE to pivot pin.

NOTE

Do not crush side stand switch during installation.

2. Install side stand using pivot pin and cotter pin.
3. Connect spring to side stand and spring pin.
4. Remove REAR WHEEL SUPPORT STAND (Part No. B-41174).
5. Inspect side stand and sidestand switch for proper operation.

REMOVAL

1. See [Figure 2-111](#). Remove left side switch housing (13).
2. Loosen clutch adjuster and remove cable (8).
3. Unplug clutch interlock (9).
4. Remove hand grip (12)
5. Loosen lever holder bolt (4) and slide off of handlebar (3).
6. Slide rubber boot off the throttle cable adjusters. Loosen cable adjuster lock on each adjuster.
7. Remove two screws on front housing. Separate housings (14) from handlebar.
8. Remove cables from notches in housings.
9. Unhook ferrules from cable wheel.
10. Remove throttle grip (15).
11. Remove front master cylinder clamp bolts.
12. Remove master cylinder.
13. Remove handlebar clamp screws (1) and riser caps (2).
14. Remove handlebar (3).

INSTALLATION

1. Position bar (3) on risers.
2. Install riser caps (2) and bolts (1).
3. Tighten bolts in steps maintaining even gap between riser and cap. Final torque to 10-12 ft-lbs. (13.6-16.3 Nm).
4. Install master cylinder. Tighten master cylinder clamp bolts to 80-120 **in-lbs.** (9-14 Nm).
5. Install throttle grip.
6. Hook ferrules to cable wheel. Position cables in notches of switch housing (14).
7. Position housings on right handlebar. Front housing has locating pin that must align with hole in handlebar. Install fasteners, longer screw on bottom. Tighten fasteners to 19-23 **in-lbs** (2-3 Nm).
8. Plug in front brake lever switch (16).
9. Install clutch perch. Torque clutch lever screw (4) to 50-60 in-lbs (5.6-6.8 Nm).
10. Install hand grip (12).
11. Install clutch cable (8).
12. Adjust clutch. See [1.9 CLUTCH](#).
13. Plug terminal into clutch interlock switch (9).
14. Install left side switch housing (13). Torque fasteners to 19-23 **in-lbs** (2-3 Nm).

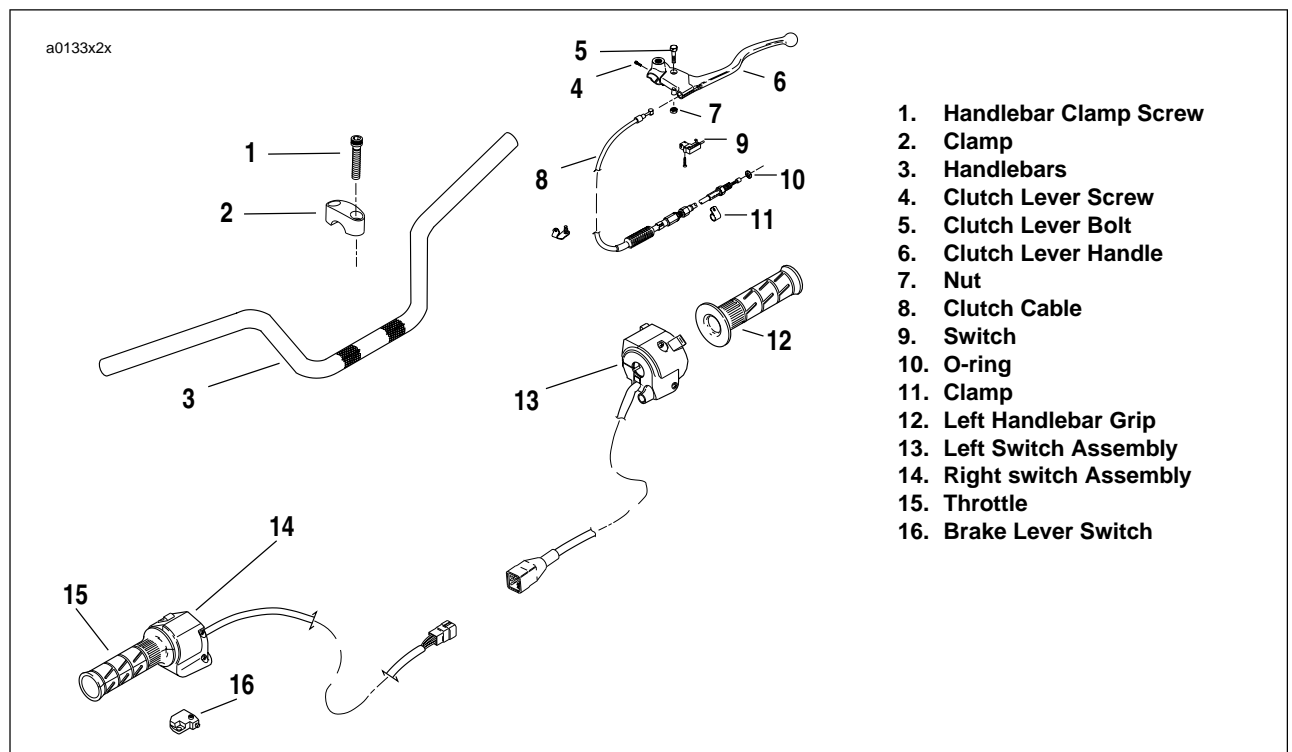

Figure 2-111. Handlebar Assembly

FRONT ISOLATOR

Removal

1. Remove seat. See 2.29 SEAT.
2. Remove fuel tank. See 4.2 FUEL TANK COVER/FUEL TANK.
3. Raise motorcycle until front suspension is unloaded.
4. Remove muffler, and support motor with jack. When isolator is detached powertrain may move. See 2.21 EXHAUST SYSTEM.
5. Cut horn cable tie.
6. Remove clutch cable tie.
7. See Figure 2-112. Loosen front ground strap bolt for clearance.
8. See Figure 2-113. Remove two outboard isolator bolts (1).
9. Remove main isolator bolt (2) and nut. Discard nut.
10. Remove isolator.

Installation

1. See Figure 2-113. Position new isolator in frame.
2. Install two outboard isolator bolts (1). Torque 30-33 ft-lbs (40.7-44.7 Nm).
3. Install main isolator bolt and **new** nut (2). Tighten main isolator bolt to 63-70 ft-lbs (85-95 Nm).
4. Tighten front ground strap bolt to 30-33 ft-lbs (40.7-44.7 Nm)
5. Install clutch cable to clip.
6. Install horn tie wrap.
7. Install fuel tank. See 4.2 FUEL TANK COVER/FUEL TANK.
8. Install seat. See 2.29 SEAT.



Figure 2-112. Front Tiebar Bolt

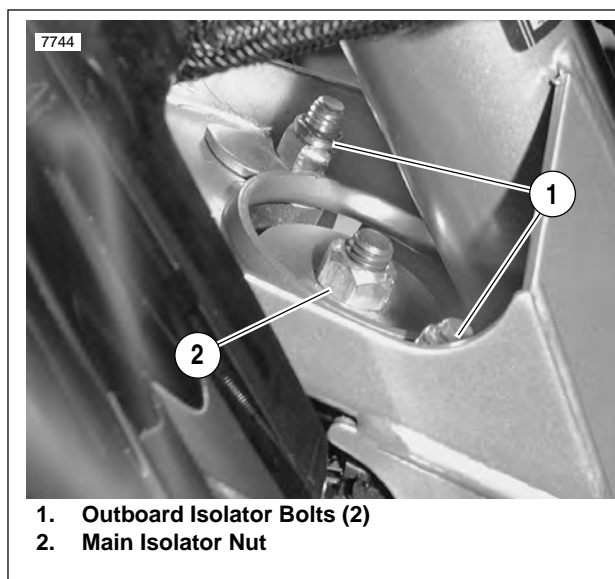

Figure 2-113. Front Isolator Bolts

WARNING

After installing seat, pull upward on front of seat to be sure it is locked in position. If seat is loose, it could shift during vehicle operation, causing loss of control of vehicle and death or serious injury.

REAR ISOLATOR

Removal

1. Remove seat. See [2.29 SEAT](#).
2. Remove battery. See [7.16 BATTERY](#).

WARNING

Always disconnect the negative battery cable first. If the positive battery cable should contact ground with the negative cable installed, the resulting sparks may cause a battery explosion which could result in death or serious personal injury.

3. Support rear of motorcycle.
4. Remove rear shock. See [2.16 REAR SHOCK ABSORBER](#).
5. Remove muffler and support motor with jack. When isolator is detached powertrain may move. See [2.21 EXHAUST SYSTEM](#)
6. See [Figure 2-114](#). Remove two allen bolts connecting frame to isolator.
7. See [Figure 2-115](#). Remove four bolts (2) connecting isolator (1) to engine.

NOTE

It may be necessary to raise or lower motorcycle to remove isolator.

Installation

1. Clean engine bolt holes and bolts. Do not re-tap holes.
2. Apply LOCTITE 243 BLUE to bolts and install four isolator-to-engine bolts. Torque bolts to 32-34 ft-lbs (46.1-50.2 Nm).
3. Apply LOCTITE 272 RED to the two frame-to-isolator bolts. Torque bolts to 30-33 ft-lbs (40.7-44.7 Nm).
4. Install rear shock absorber. See [2.16 REAR SHOCK ABSORBER](#).
5. Install battery. See [7.16 BATTERY](#).

WARNING

Always connect positive battery cable first. If the positive cable should contact ground with the negative cable installed, the resulting sparks may cause a battery explosion which could result in death or serious injury.

6. Install seat. See [2.29 SEAT](#).

WARNING

After installing seat, pull upward on front of seat to be sure it is locked in position. If seat is loose, it could shift during vehicle operation, causing loss of control of vehicle and death or serious injury.

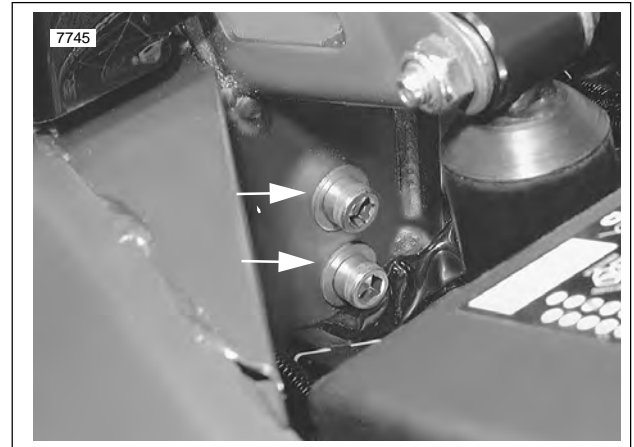

Figure 2-114. Frame-to-Isolator Bolts

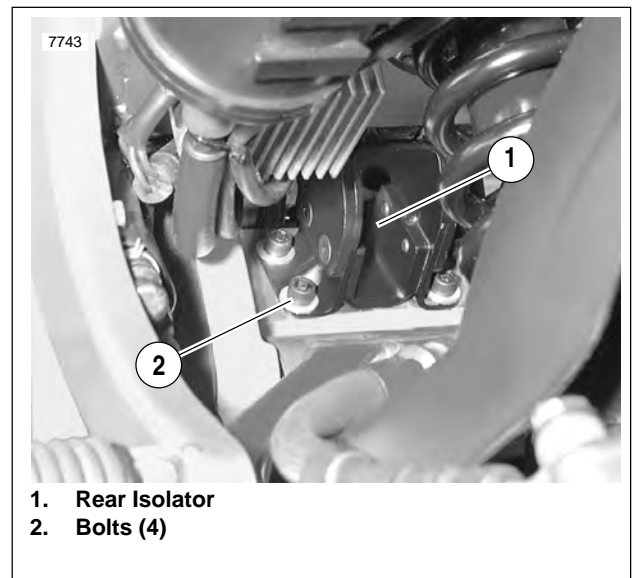

Figure 2-115. Rear Engine Mount Isolator

NOTES

Table Of Contents

SUBJECT	PAGE NO.
3.1 Specifications	3-1
3.2 Engine	3-5
3.3 Stripping Motorcycle For Engine Repair/Removal	3-7
3.4 Engine Installation	3-14
3.5 Cylinder Head	3-20
3.6 Cylinder And Piston	3-32
3.7 Lubrication System	3-41
3.8 Oil Hose Routing	3-42
3.9 Oil Reservoir	3-43
3.10 Oil Pressure Indicator Switch	3-44
3.11 Crankcase Breathing System	3-45
3.12 Oiling System	3-46
3.13 Oil Pump	3-47
3.14 Oil Filter Mount	3-50
3.15 Hydraulic Lifters	3-51
3.16 Gearcase Cover And Cam Gears	3-53
3.17 Crankcase	3-62

GENERAL		
Type	Single cylinder, air cooled, four-stroke	
Horsepower @RPM	30 @ 6500	
Torque ft-lbs @ RPM	27 @ 3200	
Compression Ratio	9.2: 1	
Bore	3.50 in.	88.8 mm
Stroke	3.125 in.	79.375 mm
Engine Displacement	30 cu. in.	492 cc
Oil Capacity (with filter change)	2.0 quarts	1.89 liters

ENGINE IGNITION SPECIFICATIONS	
Timing Advance (during engine cranking)	11° BTDC
Timing Advance (at 1200 RPM)	20° BTDC
Regular Idle	1200 RPM
Fast Idle	2000 RPM

NOTE

Service wear limits are given as a guideline for measuring components that are not **new**. For measurement specifications not given under SERVICE WEAR LIMITS, see NEW COMPONENTS.

VALVE		NEW COMPONENTS		SERVICE WEAR LIMITS	
Fit in guide	Exhaust	0.0015-0.0033 in.	0.0381-0.0838 mm	0.0040 in.	0.1016 mm
	Intake	0.0008-0.0026 in.	0.0200-0.0700 mm	0.0035 in.	0.0889 mm
Seat width		0.040-0.062 in.	1.016-1.575 mm	0.090 in.	2.286 mm
Stem protrusion from cylinder valve pocket		1.975-2.011 in.	50.165-51.079 mm	2.031 in.	51.587 mm

OUTER VALVE SPRING		NEW COMPONENTS		SERVICE WEAR LIMITS	
Free length		2.105-2.177 in.	53.467-55.296 mm	2.105 in. (min)	53.467 mm (min)
Intake	1.751-1.848 in. (closed)	72-92 lbs	33-42 kg		
	1.286-1.383 in. (open)	183-207 lbs	83-94 kg		
Exhaust	1.751-1.848 in. (closed)	72-92 lbs	33-42 kg		
	1.332-1.429 in. (open)	171-195 lbs	78-88 kg		

INNER VALVE SPRING		NEW COMPONENTS		SERVICE WEAR LIMITS	
Free length		1.926-1.996 in.	48.920-50.698 mm	1.926 in. (min)	48.920 mm (min)
Intake	1.577-1.683 in. (closed)	38-49 lbs	17-22 kg		
	1.112-1.218 in. (open)	98-112 lbs	44-51 kg		
Exhaust	1.577-1.683 in. (closed)	38-49 lbs	17-22 kg		
	1.158-1.264 in. (open)	91-106 lbs	41-48 kg		

ROCKER ARM	NEW COMPONENTS		SERVICE WEAR LIMITS	
Shaft fit in bushing (loose)	0.0005-0.0020 in.	0.0127-0.0508 mm	0.0035 in.	0.0889 mm
End clearance	0.003-0.013 in.	0.076-0.330 mm	0.025 in.	0.635 mm
Bushing fit in rocker arm (tight)	0.004-0.002 in.	0.102-0.0559 mm		
Rocker arm shaft fit in rocker cover (loose)	0.0007-0.0022 in.	0.018-0.056 mm	0.0035 in.	0.0889 mm

PISTON	NEW COMPONENTS		SERVICE WEAR LIMITS		
Compression ring gap (top and 2nd)	0.007-0.020 in.	0.178-0.508 mm	0.032 in.	0.813 mm	
Oil control ring rail gap	0.009-0.052 in.	0.229-1.321 mm	0.065 in.	1.651 mm	
Compression ring side clearance	Top	0.0020-0.0045 in.	0.0508-0.1143 mm	0.0065 in.	0.1651 mm
	2nd	0.0016-0.0041 in.	0.0406-0.1041 mm	0.0065 in.	0.1651 mm
Oil control ring side clearance	0.0016-0.0076 in.	0.0406-0.1930 mm	0.0094 in.	0.2388 mm	
Pin fit (loose, at room temperature)	0.00005-0.00045 in.	0.00127-0.01143 mm	0.00100 in.	0.02540 mm	

CYLINDER HEAD	NEW COMPONENTS		SERVICE WEAR LIMITS	
Valve guide in head (tight)	0.0033-0.0020 in.	0.0838-0.0508 mm		
Valve seat in head (tight)	0.0035-0.0010 in.	0.0889-0.0254 mm		
Head gasket surface (flatness)	0.006 in. total	0.152 mm total	0.006 in. total	0.152 mm total

CYLINDER	NEW COMPONENTS		SERVICE WEAR LIMITS		
Taper			0.002 in.	0.051 mm	
Out of round			0.003 in.	0.076 mm	
Warpage (gasket surfaces)	Top		0.006 in.	0.152 mm	
	Base		0.008 in.	0.203 mm	
Bore diameter ± 0.0002 in.	Standard	3.4978 in.	88.8441 mm	3.5008 in.	88.9203 mm
	0.005 OS	3.502 in.	88.951 mm	3.5050 in.	89.0270 mm
	0.010 OS	3.507 in.	89.078 mm	3.5100 in.	89.1540 mm
OS=over size	0.020 OS	3.517 in.	89.332 mm	3.5200 in.	89.4080 mm
	0.030 OS	3.527 in.	89.586 mm	3.5300 in.	89.6620 mm

CONNECTING ROD	NEW COMPONENTS		SERVICE WEAR LIMITS	
Piston pin fit (loose)	0.00125-0.00175 in.	0.03175-0.04445 mm	0.00200 in.	0.05080 mm
Side play between flywheels	0.005-0.025 in.	0.127-0.635 mm	0.030 in.	0.762 mm
Fit on crankpin (loose)	0.0004-0.0017 in.	0.0102-0.0432 mm	0.0027 in.	0.0686 mm
Connecting rod race ID	1.6245-1.6250 in.	41.2623-41.2750 mm	1.6270 in.	41.3258 mm

HYDRAULIC LIFTER	NEW COMPONENTS		SERVICE WEAR LIMITS	
Fit in guide	0.0008-0.0020 in.	0.0203-0.0508 mm	0.0030 in.	0.0762 mm
Roller fit	0.0006-0.0010 in.	0.0152-0.0254 mm	0.0015 in.	0.0381 mm
Roller end clearance	0.008-0.022 in.	0.203-0.559 mm	0.026 in.	0.660 mm

OIL PUMP		NEW COMPONENTS		SERVICE WEAR LIMITS	
Oil pressure	1000 RPM	7-12 PSI	48-83 KPa		
	2500 RPM	10-17 PSI	69-117 KPa		
Shaft to pump clearance		0.0025 in.	0.0635 mm		
Feed/scavenge inner/outer gerotor clearance		0.003 in.	0.076 mm	0.004 in.	0.102 mm

GEARCASE	NEW COMPONENTS		SERVICE WEAR LIMITS	
Cam gear shaft in bushing (loose)	0.0007-0.0022 in.	0.0178-0.0559 mm	0.003 in.	0.076 mm
Cam gear shaft end play (min)	0.005-0.024 in.	0.127-0.610 mm	0.025 in.	0.635 mm
Intake cam gear shaft end play (min)	0.006-0.024 in.	0.152-0.610 mm	0.040 in.	1.016 mm

FLYWHEEL		NEW COMPONENTS		SERVICE WEAR LIMITS	
Runout	Flywheels at rim	0.000-0.010 in.	0.000-0.254 mm	0.010 in.	0.254 mm
	Shaft at flywheel end	0.000-0.002 in.	0.000-0.051 mm	0.002 in.	0.051 mm
End play		0.001-0.005 in.	0.025-0.127 mm	0.005 in.	0.127 mm

SPROCKET SHAFT BEARING	NEW COMPONENTS		SERVICE WEAR LIMITS	
Outer race fit in crankcase (tight)	0.0004-0.0024 in.	0.0102-0.0610 mm		
Bearing inner race fit on shaft (tight)	0.0002-0.0015 in.	0.0051-0.0381 mm		

PINION SHAFT BEARINGS	NEW COMPONENTS		SERVICE WEAR LIMITS	
Pinion shaft journal diameter	1.2496-1.2500 in.	31.7398-31.7500 mm	1.2496 in. (min)	31.7398 mm (min)
Outer race diameter in right crankcase	1.5646-1.5652 in.	39.7408-39.7561 mm	1.5672 in. (max)	39.8069 mm (max)
Bearing running clearance	0.00012-0.00088 in.	0.00305-0.02235 mm		
Fit in cover bushing (loose)	0.0023-0.0043 in.	0.0584-0.1092 mm	0.0050 in.	0.1270 mm

TORQUE VALUES

ITEM	TORQUE		NOTES
Crankcase 5/16 in. screws	15-19 ft-lbs	20.3-25.8 Nm	Page 3- 3-73
Crankcase, 3/8 in. screw	80-100 in-lbs	9.0-11.3 Nm	Page 3- 3-73
Cylinder head screws	See NOTES	See NOTES	Special pattern to tighten, page 3- 3-30
Cylinder studs	10 ft-lbs	13.6 Nm	Special method to tighten, page 3- 3-73
Flywheel end play	190-210 ft-lbs	257.6-284.7 Nm	Page 3- 3-62
Frame mount to rear engine	30-33 ft-lbs	41-45 Nm	LOCTITE® thread locker 262 (red), page 3- 3-15
Front isolator mounting bolt	63-70 ft-lbs	86-95 Nm	LOCTITE® thread locker 262 (red), page 3-19
Front tie bar	30-33 ft-lbs	41-45 Nm	LOCTITE® thread locker 262 (red), page 3- 3-18
Gearcase cover screws	80-110 in-lbs	9.0-12.4 Nm	Special pattern to tighten, page 3- 3-61
Master cylinder mounting screws	4-6 ft-lbs	5.4-8.2 Nm	LOCTITE® thread locker 243 (blue), page 3- 3-17
Oil filter adapter	8-12 ft-lbs	10.8-16.3 Nm	LOCTITE® thread locker 243 (blue), page 3- 3-50
Oil pressure signal light switch	5-7 ft-lbs	6.8-9.5 Nm	Page 3- 3-50
Oil pump cover screws	125-150 in-lbs	14.1-16.9 Nm	TORX, page 3- 3-49
Oil pump mounting screws	125-150 in-lbs	14.1-16.9 Nm	Page 3- 3-49
Pinion shaft nut	See NOTES	See NOTES	Special method to tighten, page 3- 3-60
Rear engine mount to crankcase	34-37 ft-lbs	46-50 Nm	LOCTITE® thread locker 243 (blue), page 3- 3-15
Rocker box cover screws	10-13 ft-lbs	13.6-17.6 Nm	Page 3- 3-31
Rocker box to head bolts	10-14 ft-lbs	13.6-19 Nm	Different sizes, page 3- 3-31
Rocker box to head bolts	12-14 ft-lbs	16.3-19.0 Nm	Different sizes, page 3- 3-30
Rocker box to head bolts	130-150 in-lbs	14.7-17.9 Nm	Different sizes, page 3- 3-31
Rocker box to head bolts	13-15 ft-lbs	17.6-20 Nm	Different sizes, page 3- 3-30
Rocker box to head bolts	15-19 ft-lbs	20.3-26 Nm	Different sizes, page 3- 3-31
Rocker box to head bolts	7-9 ft-lbs	9.5-12.2 Nm	Different sizes, page 3- 3-30
Side stand bracket	38-41 ft-lbs	51-55 Nm	LOCTITE® thread locker 262 (red), page 3- 3-14
Swing arm pinch bolt	18 ft-lbs	24 Nm	LOCTITE® thread locker 243 (blue), page 3- 3-14
Swing arm pivot shaft	24-26 ft-lbs	32-35 Nm	Page 3- 3-14
Top rear tie bar	30-33 ft-lbs	41-45 Nm	LOCTITE® thread locker 262 (red), page 3- 3-18
Upper front tie bar	30-33 ft-lbs	41-45 Nm	LOCTITE® thread locker 262 (red), page 3- 3-18

FUEL

Gasoline/alcohol Blends

The Buell Blast P3 motorcycle has been designed to obtain the best performance and efficiency using unleaded gasoline (**87 pump octane** or higher). Some fuel suppliers sell gasoline/alcohol blends as a fuel. The type and amount of alcohol added to the fuel is important.

- **DO NOT USE GASOLINES CONTAINING METHANOL.** Using gasoline/methanol blends will result in starting and driveability deterioration and damage to critical fuel system components.
- Gasolines containing **ETHANOL**: Gasoline/ethanol blends are mixture of 10% ethanol (Grain alcohol) and 90% unleaded gasoline. Gasoline/ethanol blends can be used in your motorcycle if the ethanol content does not exceed 10%.
- Gasolines containing **ETHER**: Gasoline/ether blends are a mixture of gasoline and as much as 15% ether. Gasoline/ether blends can be used in your motorcycle if the ether content does not exceed 17%.
- **REFORMULATED OR OXYGENATED GASOLINES (RFG)**: “Reformulated gasoline” is a term used to describe gasoline blends that are specifically designed to burn cleaner than other types of gasoline, leaving fewer “tailpipe” emissions. They are also formulated to evaporate less when you are filling your tank. Reformulated gasolines use additives to “oxygenate” the gas. Your motorcycle will run normally using this type of gas. Buell recommends you use it when possible, as an aid to cleaner air in our environment.

Because of their generally higher volatility, these blends may adversely affect the starting, driveability and fuel efficiency of your motorcycle. If you experience these problems, Buell recommends that you operate your motorcycle on straight, unleaded gasoline.

LUBRICATION

The engine has a force-feed (pressure) type oiling system, incorporating oil feed and return pumps in one pump body, with one check valve on the oil feed side. The feed pump forces oil to the engine, lubricating lower connecting rod bearings, rocker arm bushings, valve stems, valve springs, push rods and tappets. Cylinder wall, piston, piston pin, timing gears, bushings and main bearings are lubricated by oil spray thrown off connecting rods and crankshaft, and by oil draining from each rocker box through an internal drain passage in each cylinder and each tappet guide. Oil is transferred to the teeth of all the cam gears by way of the gear meshing action. The oil-scavenging section of the pump returns oil to the tank from the engine. See [3.7 LUBRICATION SYSTEM](#) for more information.

ADJUSTMENT/TESTING

General

When an engine needs repair, it is not always possible to determine definitely beforehand whether repair is possible with only cylinder head, cylinder and piston disassembled or whether complete engine disassembly is required for crankcase repair.

Most commonly, only cylinder head and cylinder repair is needed (valves, rings, piston, etc.) and it is recommended procedure to service these units first, allowing engine crankcase to remain in frame.

See [DISASSEMBLING ENGINE FOR CYLINDER HEAD REPAIR/ENGINE REMOVAL](#), under [3.3 STRIPPING MOTORCYCLE FOR ENGINE REPAIR/REMOVAL](#) to strip motorcycle for removal of cylinder head, cylinder, and piston.

After disassembling “upper end” only, it may be found that crankcase repair is necessary. In this situation, remove the engine crankcase from the chassis.

CAUTION

If engine is removed from chassis, do not lay engine on primary side. Placing engine on primary side will damage clutch cable end fitting. If fitting is damaged, clutch cable must be replaced.

See [1.24 TROUBLESHOOTING](#) section. Symptoms indicating a need for engine repair are often misleading, but generally, if more than one symptom is present, possible causes can be narrowed down to make at least a partial diagnosis. An above-normal consumption of oil, for example, could be caused by several mechanical faults. However, when accompanied by blue-gray exhaust smoke and low engine compression, it indicates the piston rings need replacing. Low compression by itself, however, may indicate improperly seated valves, in addition to or in lieu of worn piston rings.

Most frequently, valves, rings, pins, bushings, and bearings need attention at about the same time. If the possible causes can be narrowed down through the process of elimination to indicate any one of the above components is worn, it is best to give attention to all of the cylinder head and cylinder parts.

Compression Test Procedure

Combustion chamber leakage can result in unsatisfactory engine performance. A compression test can help determine the source of cylinder leakage. Use [CYLINDER COMPRESSION GAUGE](#) (Part No. HD-33223-1).

A proper compression test should be performed with the engine at normal operating temperature when possible. Proceed as follows:

CAUTION

After completing the compression test(s), make sure that the throttle plate is in the closed position before starting engine. Engine will start at an extremely high RPM if throttle plate is left open.

1. Disconnect spark plug wire. Clean around plug base and remove plug.
2. Connect compression tester to cylinder.
3. With carburetor throttle plates in wide open position, crank engine continuously through 5-7 full compression strokes.
4. Note gauge readings at the end of the first and last compression strokes. Record test results.
5. Compression is normal if final readings are 120 psi (827 kPa) or more.
6. Inject approximately 1/2 oz. (15 ml) of SAE 30 oil into cylinder and repeat the compression test. Readings that are considerably higher during the second test indicate worn piston rings.

Table 3-1. Compression Test Results

DIAGNOSIS	TEST RESULTS
Ring trouble	Compression low on first stroke; tends to build up on the following strokes but does not reach normal; improves considerably when oil is added to cylinder.
Valve trouble	Compression low on first stroke; does not build up much on following strokes; does not improve considerably with the addition of oil.
Head gasket leak	Same reaction as valve trouble.

Cylinder Leakage Test

The cylinder leakage test pinpoints engine problems including leaking valves, worn, broken or stuck piston rings and blown head gaskets. The cylinder leakage tester applies compressed air to the cylinder at a controlled pressure and volume, and measures the percent of leakage from the cylinder.

Use a CYLINDER LEAKDOWN TESTER (Part No. HD-35667A) and follow the specific instructions supplied with the tester.

The following are some general instructions that apply to Buell motorcycle engines:

1. Run engine until it reaches normal operating temperature.
2. Stop engine. Clean dirt from around spark plug and remove spark plug.
3. Remove air cleaner and set carburetor throttle in wide open position.
4. Remove timing inspection plug from crankcase.
5. The piston, in cylinder being tested, must be at top dead center of compression stroke during test.

6. To keep engine from turning over when air pressure is applied to cylinder, engage transmission in fifth gear and lock the rear brake.
7. Following the manufacturer's instructions, perform a cylinder leakage test on the front cylinder. Make a note of the percent leakdown. Any cylinder with 12% leakdown, or more, requires further attention.
8. See [Table 3-2](#). Listen for air leaks at carburetor intake, exhaust, head gasket and timing inspection hole.

NOTE

If air is escaping through valves, check push rod length.

9. Repeat procedure on rear cylinder.

CAUTION

After completing the compression test(s), make sure that the throttle plate is in the closed position before starting engine. Engine will start at an extremely high RPM if throttle plate is left open.

Table 3-2. Air Leakage Test

AIR LEAK LOCATION	POSSIBLE CAUSES
Carburetor intake	Intake valve leaking.
Exhaust pipe	Exhaust valve leaking.
Timing inspection hole	Piston rings leaking. Worn or broken piston. Worn cylinder.
Head gasket	Leaking gasket.

Diagnosing Smoking Engine or High Oil Consumption

Perform [COMPRESSION TEST PROCEDURE](#) or [Cylinder Leakage Test](#) as described previously. If further testing is needed, remove suspect head(s) and inspect the following:

- Valve guide seals.
- Valve guide-to-valve stem clearance.
- Gasket surface of both head and cylinder.

STRIPPING MOTORCYCLE FOR ENGINE REPAIR/ REMOVAL

DISASSEMBLING ENGINE FOR CYLINDER HEAD REPAIR/ENGINE REMOVAL

1. Lift and secure the motorcycle.
 - a. Place vehicle on a lift and anchor rear wheel in place. Raise lift so the top of the cylinder head is easy to access.
2. Remove seat. See [2.29 SEAT](#).

⚠ WARNING

To protect against shock and accidental start-up of vehicle, disconnect the negative battery cable before proceeding. Inadequate safety precautions could result in death or serious injury.

⚠ WARNING

Always disconnect the negative first. If the positive cable should contact ground with the negative cable installed, the resulting sparks may cause a battery explosion which could result in death or serious injury.

3. Disconnect **both** battery cables, negative cable first. See [7.16 BATTERY](#).
4. Remove fuel tank. See [7.16 BATTERY](#).
5. Remove muffler. See [2.21 EXHAUST SYSTEM](#).
6. Place jack under the motor. Use jack to lower motor.
7. Remove Horn. See [7.22 HORN](#).
8. See [Figure 3-1](#). Remove crankcase breather hose and crankcase breather from rocker box grommet.

CAUTION

See [Figure 3-2](#). Do not attempt to remove isolator mount from cylinder head. Isolator mount is an integral component and is not meant to be removed unless absolutely necessary. Repeated removals and installations will damage cylinder head threads.

NOTES:

- Remove the isolator mount **ONLY** to replace the engine, cylinder head or servicing of exhaust valve components. For all other disassembly and servicing do not remove mount from cylinder head.
 - Proceed to step 9. for engine removal, cylinder head replacement or complete cylinder head servicing including exhaust valve components.
 - For all other disassembly and related servicing procedures proceed to step 10.
9. See [Figure 3-2](#). Remove the two mounted cylinder head bolts from the front isolator/engine bracket marked "DO NOT REMOVE". See note above.

NOTES:

- For top end service proceed to step 11.
- For engine removal proceed to step 12.



Figure 3-1. Remove Crankcase Breather Hose



Figure 3-2. Cylinder Head Bolts

10. See Figure 3-3. Loosen and remove front isolator mount bolt, spacer, snubber and locknut.
11. For top end service loosen, but do not remove lower front tie bar bolts at engine and frame.
12. For engine removal, loosen and remove lower front tie bar from engine.
13. See Figure 3-4. Remove top rear tie bar at frame.

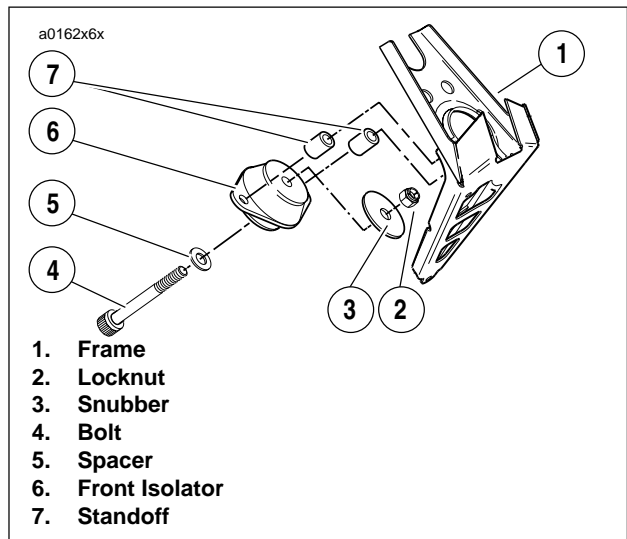

Figure 3-3. Front Isolator Mount

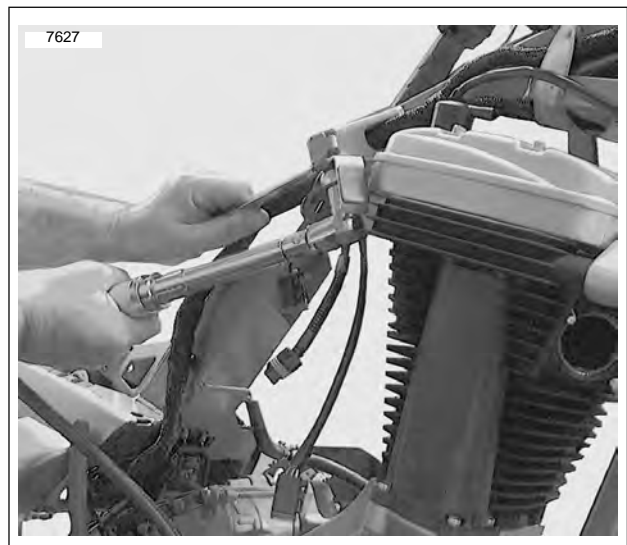

Figure 3-4. Remove Top Rear Tie Bar

14. See [Figure 3-5](#). Remove entire air cleaner and carburetor as an assembly.
- Remove screws on both air cleaner brackets.
 - See [Figure 3-6](#). Loosen hose clamp.
 - See [Figure 3-7](#). Remove crankcase breather hose.
 - See [Figure 3-8](#). Disconnect auto enrichener plug.
 - See [Figure 3-8](#). Place air cleaner and carburetor as an assembly on top of frame.

NOTES:

- See [4.3 AIR CLEANER](#) for more details about the air cleaner.
- See [3.5 CYLINDER HEAD](#). The steps mentioned previously complete disassembly preparation for top end servicing. You may now proceed with TOP END DISASSEMBLY PROCEDURES.
- If continuing engine removal proceed to step 16.

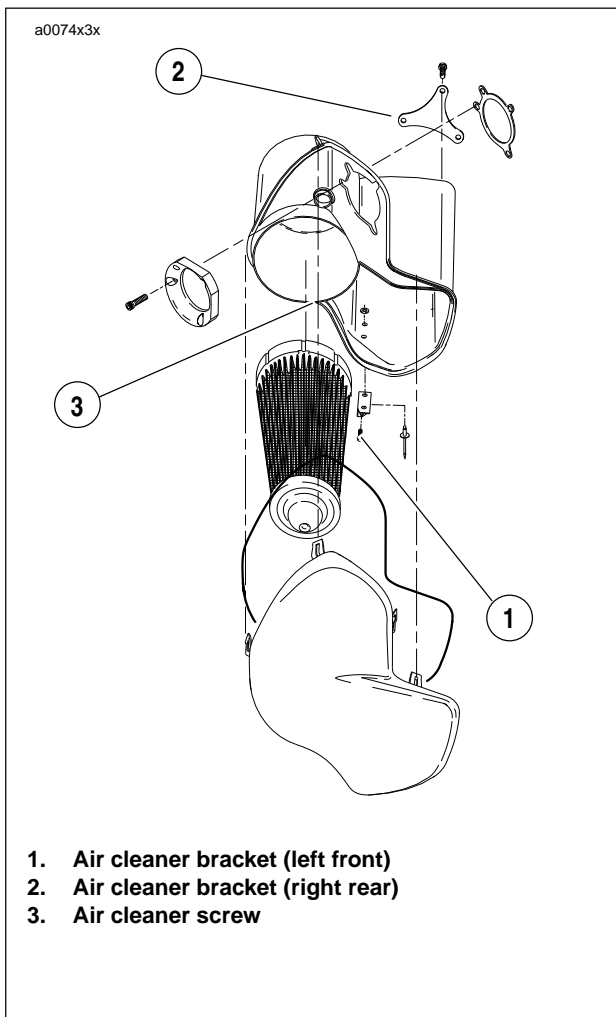

Figure 3-5. Air Cleaner Assembly



Figure 3-6. Hose Clamp

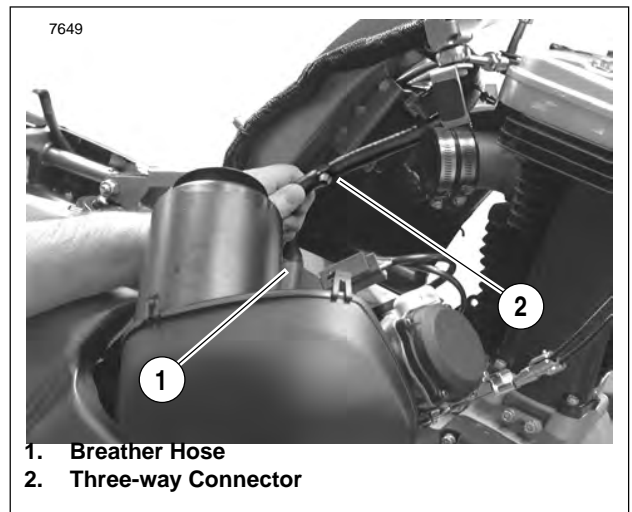

Figure 3-7. Crankcase Breather Hose

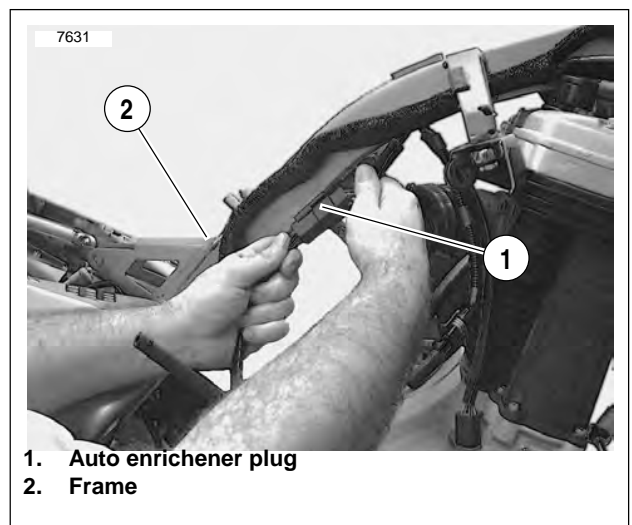

Figure 3-8. Auto Enrichener Plug

NOTE

The remaining steps are required to complete engine removal.

15. Place jack under the motor. Use jack to lower motor.
16. Move jack forward.
17. Place wooden cradle under engine.

NOTE

See [Figure 3-9](#). Remove rear master cylinder before removing sprocket cover.

18. Remove sprocket cover. See [2.23 SPROCKET COVER](#).
19. See [Figure 3-9](#). Disconnect screws at brake fluid reservoir, master cylinder and brake line bracket (items 1, 3 and 6).
20. Move belt on rear sprocket off pulley toward inside of motorcycle.
21. See [Figure 3-10](#). Remove right side rider footpeg bracket assembly. See [2.22 FOOTPEGS AND FOOTPEG SUPPORT BRACKETS](#).
22. Introduce freeplay and remove clutch cable at hand lever location. See [6.4 CLUTCH](#).

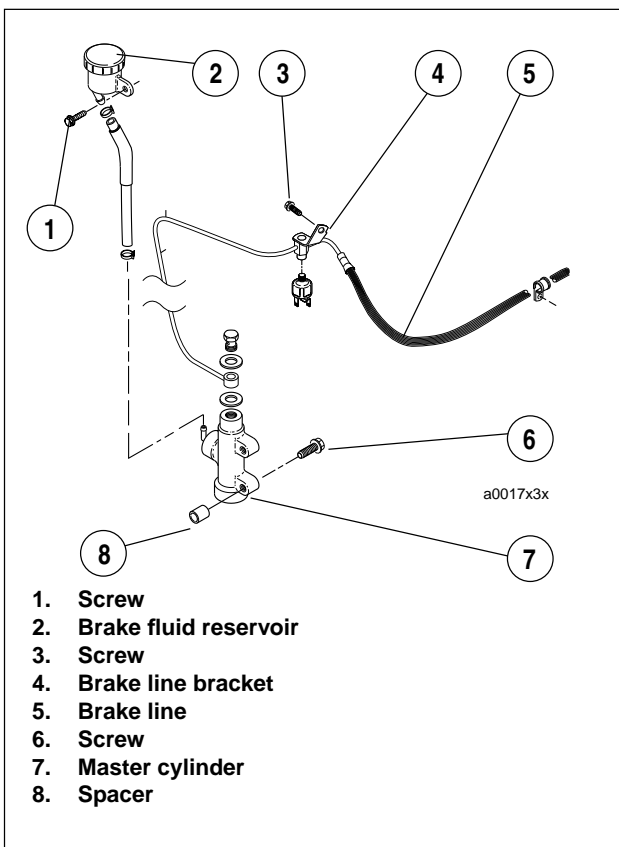

Figure 3-9. Brake Line Assembly

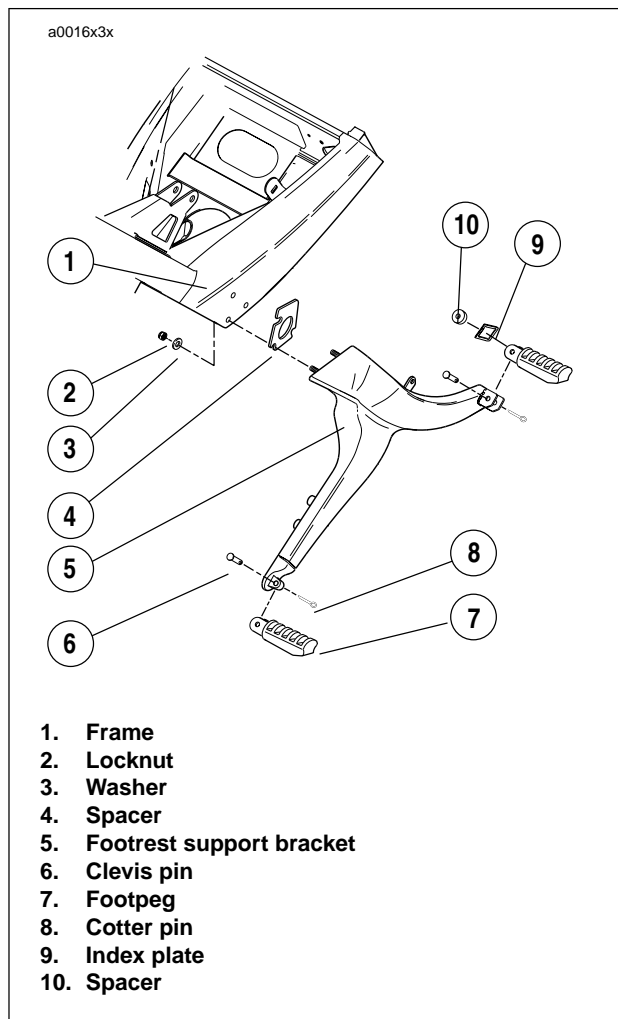

Figure 3-10. Footpeg Bracket Assembly

23. See [Table 3-3](#). Disconnect the following electrical items:

Table 3-3. Electrical Items Disconnected for Engine Disassembly

Item no.	Description	Location
1	Ignition module [10]	Located on frame backbone.
2	Speedo sensor [65]	Located under seat (right side-tucked in under cavity).
3	Side stand switch [60]	Tie wrapped to rear brake line.
4	Neutral switch [131]	Disconnect at neutral switch.
5	Oil pressure switch [120]	Disconnect at oil pressure switch.
6	Alternator stator [46]	Located under seat (left side).
7	Starter solenoid wire [128]	Disconnect at starter.
8	Spark plug wire	Located on spark plug.
9	Battery—positive wire	Disconnect at main circuit breaker.
10	Rear brake light switch [121]	Located under frame by shock absorber.

24. See [Figure 3-11](#). Place a floor hoist behind the lift. Attach straps to frame and hoist. Raise hoist until straps tighten.

25. Remove rear shock. See [2.16 REAR SHOCK ABSORBER](#).

26. See [Figure 3-12](#). Loosen nut on hose routing clamp.



Figure 3-11. Hoisting Bike



Figure 3-12. Loosen Clamp

27. See [Figure 3-13](#). Disconnect feed, return, transmission and crankcase vent lines.
28. See [Figure 3-14](#). Remove rear motor mount bolts.
29. Remove chassis from engine by performing the steps below.
 - a. Lower chassis.
 - b. Disconnect hoist from chassis.
 - c. Lower lift.
 - d. See [Figure 3-15](#). Lift chassis and roll away from engine.

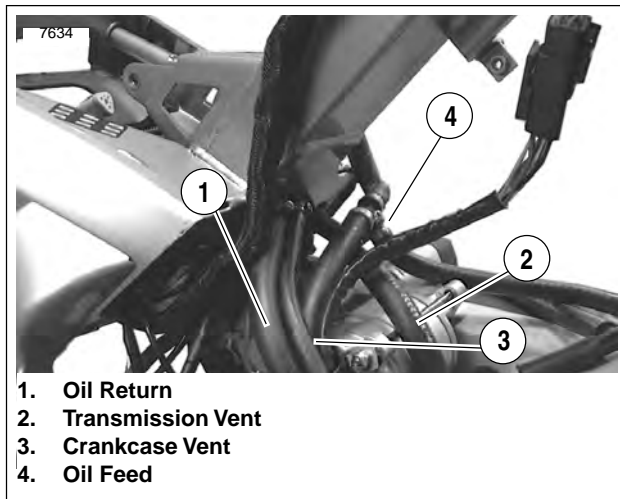

Figure 3-13. Disconnect Lines

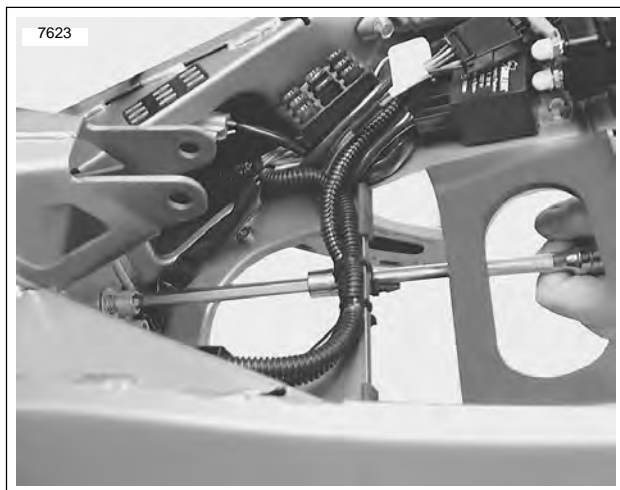

Figure 3-14. Removing Rear Motor Mount Bolts

30. See [Figure 3-16](#). Remove air cleaner box bracket.
31. See [Figure 3-17](#). Remove rear engine mount.
32. See [Figure 3-18](#). Loosen swingarm pinch bolt.



Figure 3-15. Move Chassis From Engine



Figure 3-16. Bracket

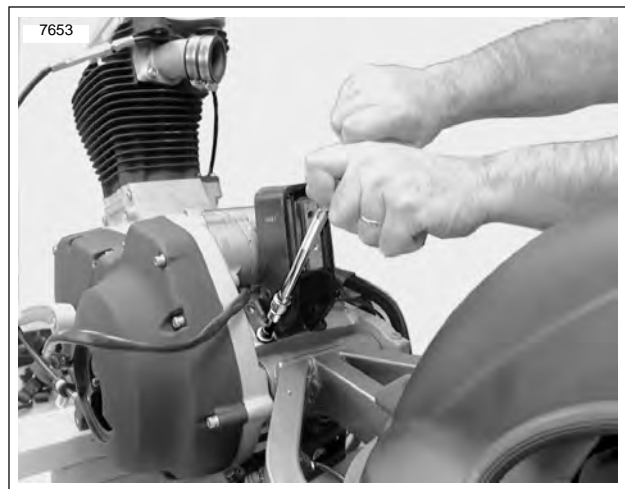

Figure 3-17. Rear Engine Mount

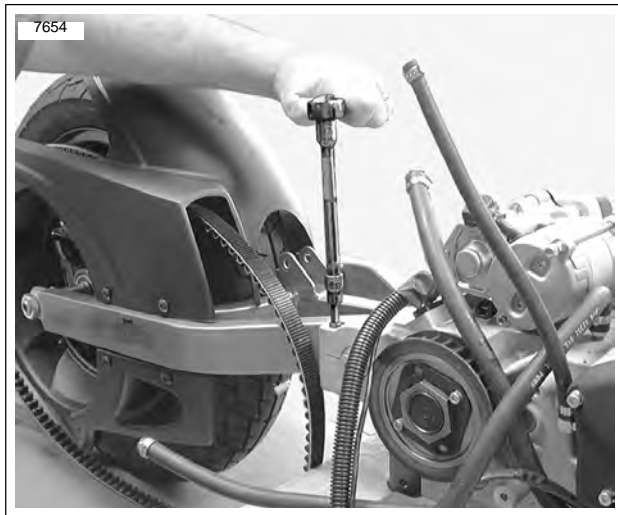

Figure 3-18. Pinch Bolt

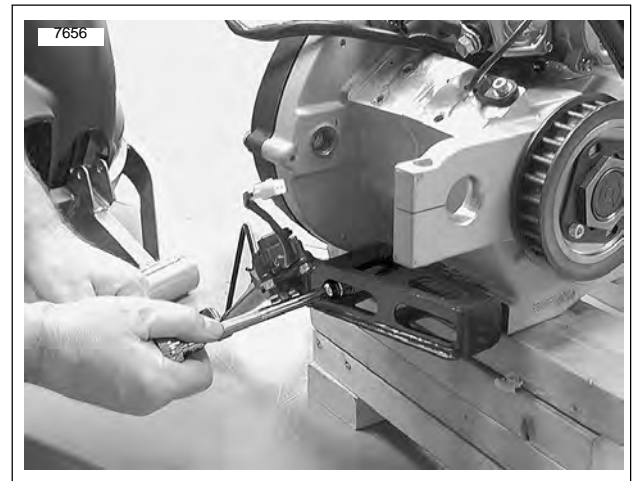

Figure 3-20. Side Stand Bracket

- 33. See [Figure 3-19](#). Remove swingarm pivot shaft and rear wheel as an assembly. See [2.20 SWINGARM](#).
- 34. See [Figure 3-20](#). Remove side stand and bracket assembly. See [2.30 SIDE STAND](#)

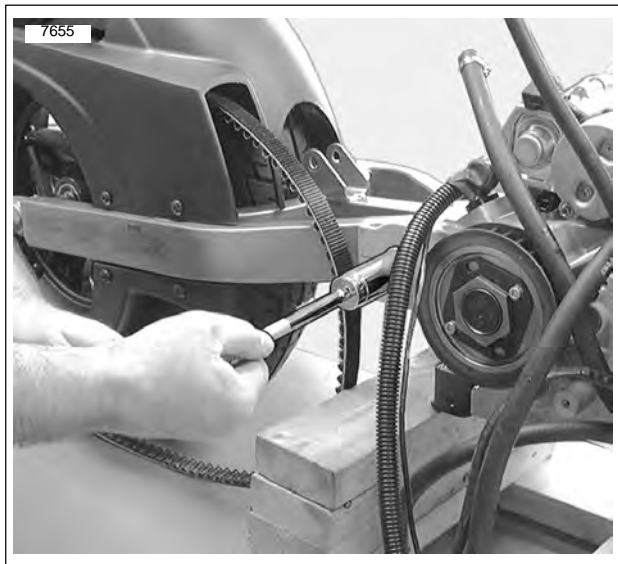

Figure 3-19. Swingarm Pivot Shaft

INSTALLING ENGINE

1. Ensure cradle is secured under engine.
2. See [Figure 3-21](#). Install side stand and bracket assembly. See [2.30 SIDE STAND](#).
 - a. Apply several drops of LOCTITE® THREAD-LOCKER 262 (red) to last few threads.
 - b. Tighten to 38-41 ft-lbs (51-55 Nm).
3. Install rear wheel. See [2.7 REAR WHEEL](#).
4. See [Figure 3-22](#). Install swingarm pivot shaft and rear wheel as an assembly. See [2.20 SWINGARM](#).
 - a. Tighten to 24-26 ft-lbs (32-35 Nm).
5. See [Figure 3-23](#). Install swingarm pinch bolt.
 - a. Apply several drops of LOCTITE® THREAD-LOCKER 243 (blue) to last few threads.
 - b. Tighten to 18 ft-lbs (24 Nm).

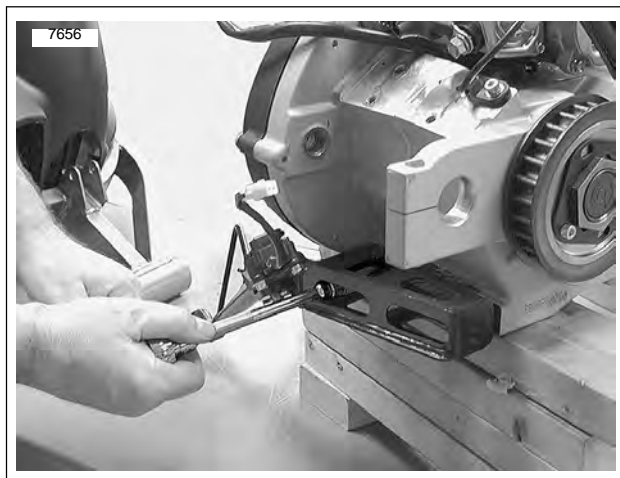

Figure 3-21. Side Stand Bracket

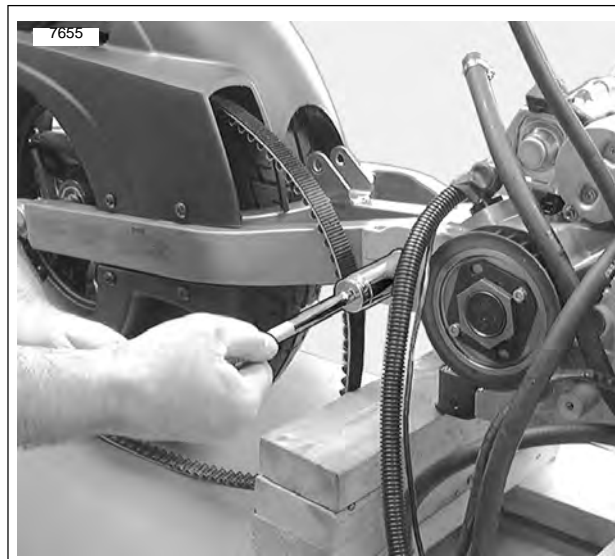

Figure 3-22. Swingarm Pivot Shaft

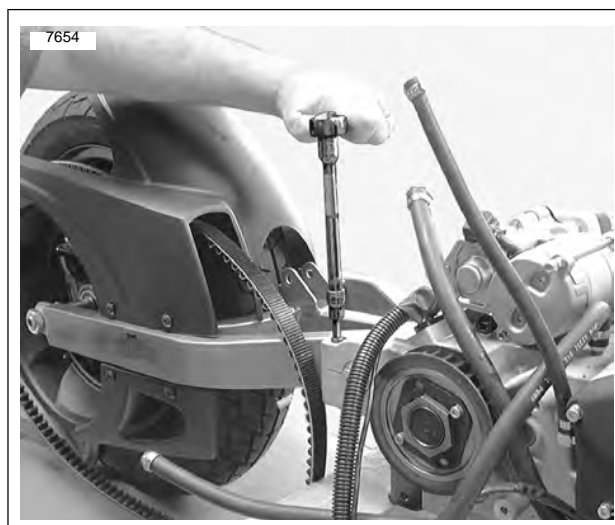

Figure 3-23. Pinch Bolt

6. See [Figure 3-24](#). Install rear engine mount.
 - a. Apply several drops of LOCTITE® THREAD-LOCKER 243 (blue) to last few threads.
 - b. Tighten to 23-27 ft-lbs (31-37 Nm).
7. See [Figure 3-25](#). Loosely install air cleaner box bracket.
8. Install chassis onto engine by performing the steps below.
 - a. See [Figure 3-26](#). Roll chassis toward engine.
 - b. Lift chassis onto engine.
 - c. Raise lift.
 - d. See [Figure 3-27](#). Attach hoist to frame; Place a floor hoist behind the lift. Attach straps to frame and hoist. Raise hoist until straps tighten.



Figure 3-24. Rear Engine Mount

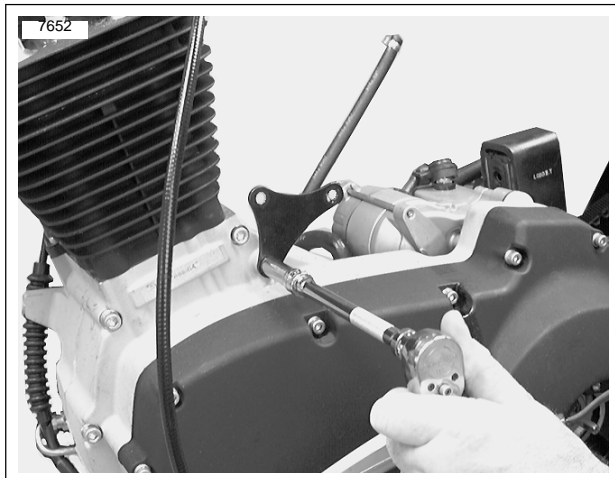

Figure 3-25. Bracket

9. Place jack under the motor. Use jack to raise motor.
10. Move jack backward.
11. See [Figure 3-28](#). Install rear motor mount bolts.
 - a. Apply several drops of LOCTITE® THREAD-LOCKER 262 (red) to last few threads.
 - b. Tighten to 30-33 ft-lbs (41-45 Nm).



Figure 3-26. Move Chassis to Engine

12. See [Figure 3-29](#). Connect feed, return, transmission and crankcase vent lines.



Figure 3-27. Hoisting Bike

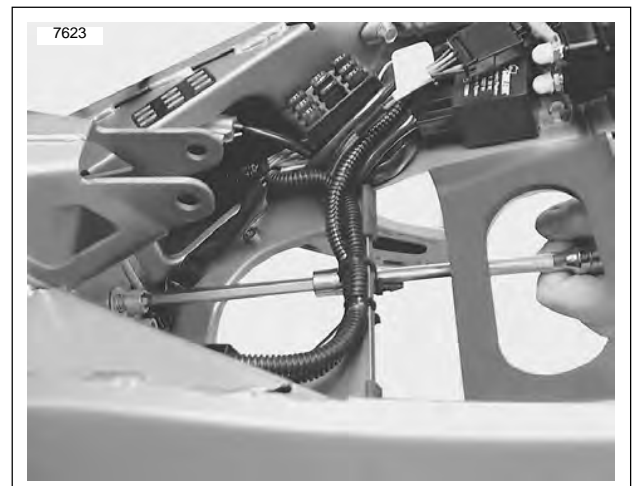

Figure 3-28. Installing Rear Motor Mount Bolts

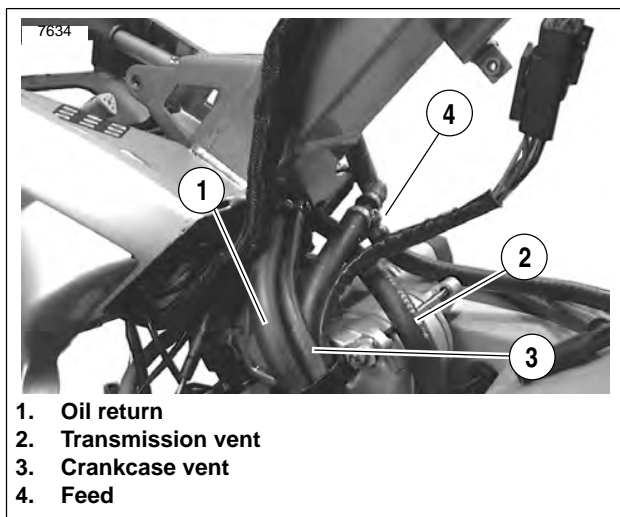

Figure 3-29. Connect Lines

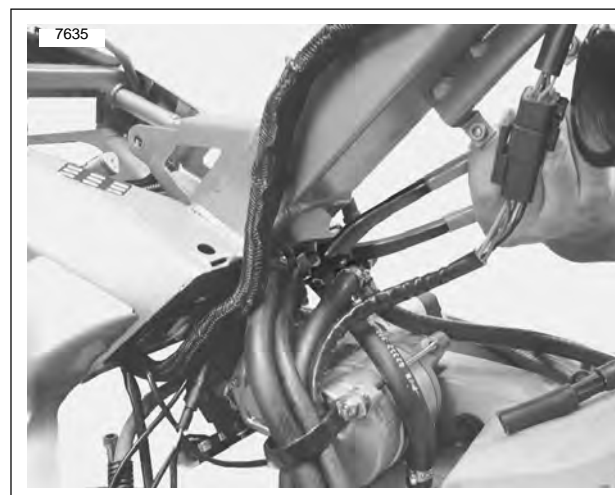

Figure 3-30. Tighten Hose Clamps

13. See [Figure 3-30](#). Tighten hose clamps using Hose Clamp Pliers, part no. HD-41137.
14. See [Figure 3-31](#). Tighten nut on hose routing clamp.
15. Install rear shock. See [2.16 REAR SHOCK ABSORBER](#).
16. See [Table 3-4. Electrical Items for Engine Assembly](#). Connect the following electrical items:

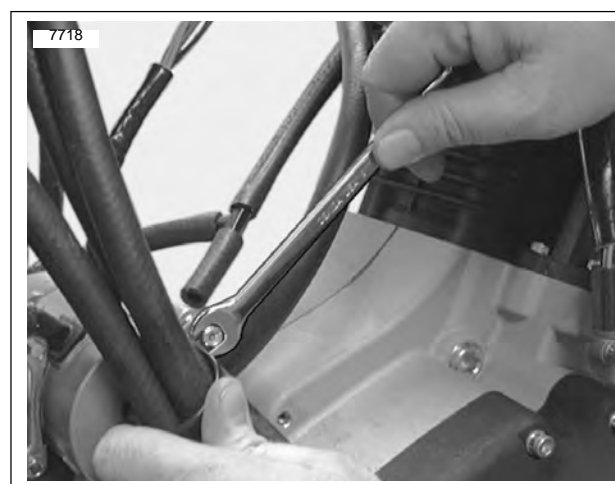

Figure 3-31. Tighten Clamp

Table 3-4. Electrical Items for Engine Assembly

Item no.	Description	Location
1	Ignition module [10]	Located on frame backbone.
2	Speedo sensor [65]	Located under seat (right side-tucked in under cavity).
3	Side stand switch [60]	Tie wrapped to rear brake line.
4	Neutral switch [131]	Disconnect at neutral switch.
5	Oil pressure switch [120]	Disconnect at oil pressure switch.
6	Alternator stator [46]	Located under seat (left side).
7	Starter solenoid wire [128]	Disconnect at starter.
8	Spark plug wire	Located on spark plug.
9	Battery—positive wire	Disconnect at main circuit breaker.
10	Rear brake light switch [121]	Located under frame by shock absorber.

17. Install clutch cable at hand lever location. See [6.4 CLUTCH](#).
18. Install drive belt. See [1.11 DRIVE BELT AND REAR SPROCKET](#).
19. Install front sprocket cover. See [2.23 SPROCKET COVER](#).
20. Install master cylinder onto footpeg bracket. See [2.22 FOOTPEGS AND FOOTPEG SUPPORT BRACKETS](#).
 - a. Apply several drops of **LOCTITE® THREAD-LOCKER 243** (blue) to last few threads.
 - b. Tighten to 4-6 ft-lbs (5.4-8.2 Nm).

NOTE:

SEE **TOP END ASSEMBLY SECTION**. The steps mentioned previously complete Assembly preparation for top end servicing. You may now proceed with **TOP END ASSEMBLY PROCEDURES**. Then proceed to step 22.

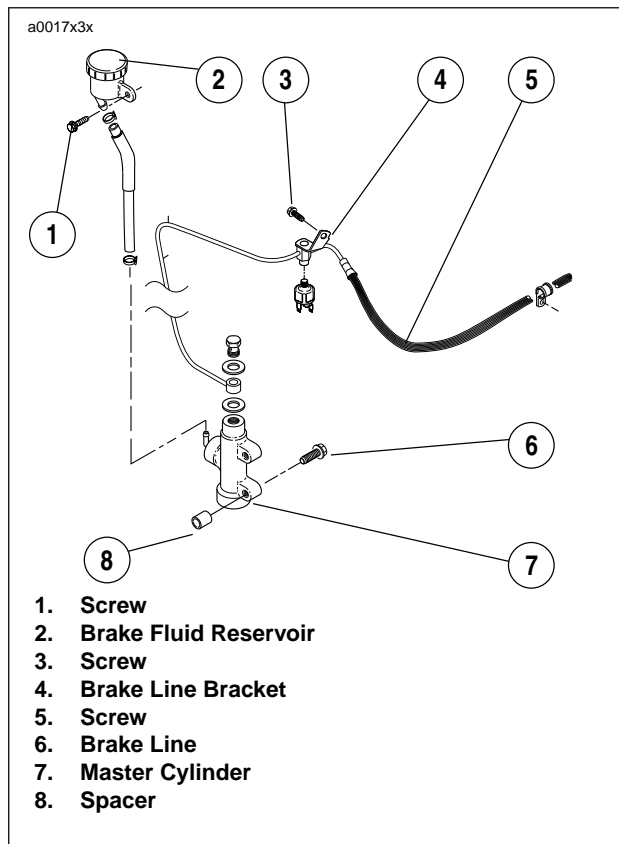

Figure 3-32. Brake Line Assembly

21. See [Figure 3-34](#). Connect auto enricher plug.
22. See [Figure 3-36](#). Install entire air cleaner assembly. See [4.3 AIR CLEANER](#).
 - c. See [Figure 3-35](#). Connect crankcase breather hose to three-way connector.
 - d. See [Figure 3-37](#). Install hose clamp.
 - e. See [Figure 3-36](#). Install and tighten screws on both air cleaner brackets.
 - f. Install screw on air cleaner cover.

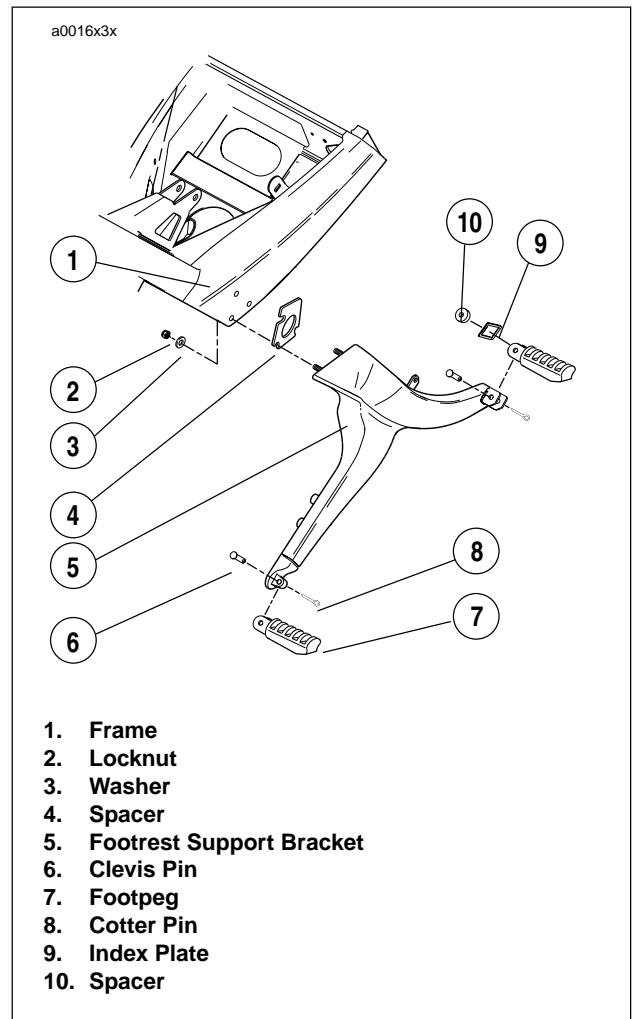

Figure 3-33. Footpeg Bracket Assembly

NOTE

See [4.3 AIR CLEANER](#) for more details on the air cleaner.

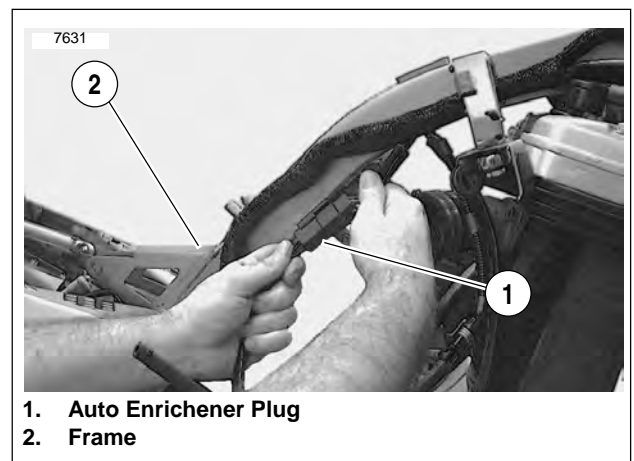
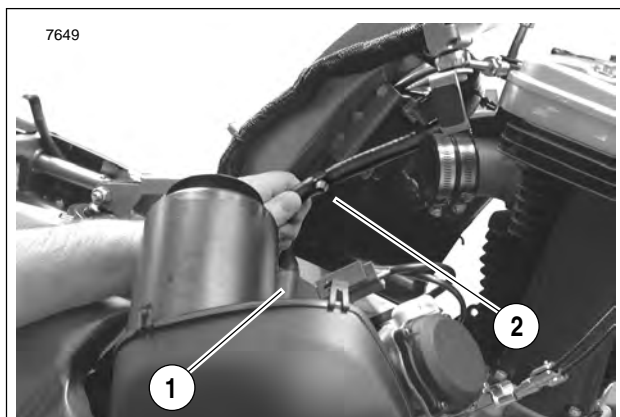
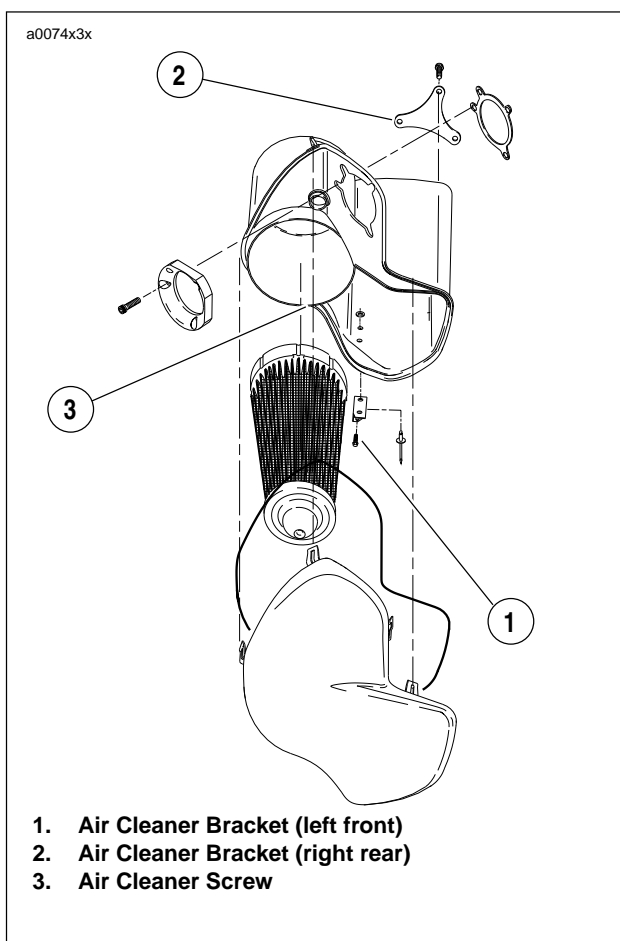

Figure 3-34. Auto Enricher Plug



1. Breather Hose
2. Three-way Connector

Figure 3-35. Crankcase Breather Hose



1. Air Cleaner Bracket (left front)
2. Air Cleaner Bracket (right rear)
3. Air Cleaner Screw

Figure 3-36. Air Cleaner Assembly



Figure 3-37. Hose Clamp

23. See [Figure 3-38](#). Install top rear tie bar at frame.
24. Tighten tie bar bolt to 30-33 ft-lbs (41-45 Nm).
25. Install ground strap bolt to engine. Tighten ground strap bolt to 30-33 ft-lbs (41-45 Nm).
26. See [Figure 3-39](#). Install front tie bar onto engine.
 - a. Apply several drops of LOCTITE® THREAD-LOCKER 262 (red) to last few threads.
 - b. Tighten to 30-33 ft-lbs (41-45 Nm).
27. See [Figure 3-40](#). Install the two mounted cylinder head bolts from the front isolator/engine bracket marked "DO NOT REMOVE".
 - a. Apply several drops of LOCTITE® THREAD-LOCKER 262 (red) to last few threads of **new** bolts.
 - b. Apply a thin film of clean HD 20W50 engine oil to both sides of **new** thick washers and to bottom of bolt heads. Exercise caution to avoid mixing oil on washers with LOCTITE on bolts.
 - c. Tighten bolts to 60 ft-lbs (81 Nm) initially and then loosen each bolt one full turn. Tighten bolts again to 60 ft-lbs (81 Nm).

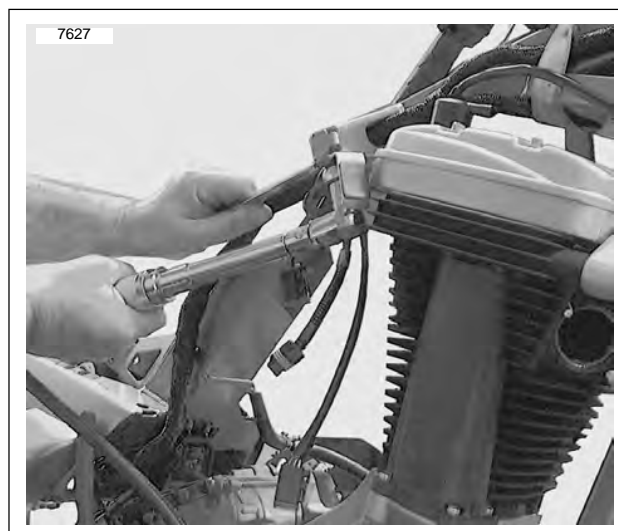

Figure 3-38. Install Top Rear Tie Bar



Figure 3-39. Install Front Tie Bar

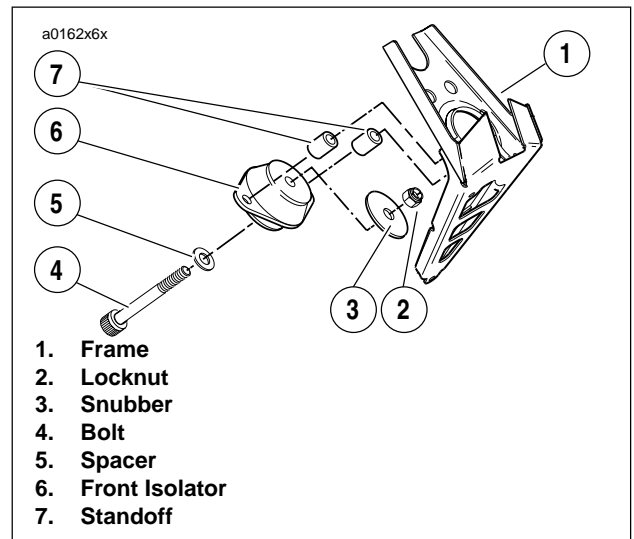

Figure 3-41. Front Isolator Mount



Figure 3-40. Cylinder Head Bolt



Figure 3-42. Install Crankcase Breather Hose

28. See [Figure 3-41](#). Install front isolator mounting bolt, spacer snubber and **new** nut.
29. Tighten front isolator mounting bolt to 63-70 ft-lbs (86-95 Nm).
30. See [Figure 3-42](#). Install crankcase breather hose and crankcase breather into rocker box grommet.
31. Install Horn. See [7.22 HORN](#).
32. Remove jack from under the motor.
33. Install muffler. See [2.21 EXHAUST SYSTEM](#).
34. Install fuel tank. See [4.2 FUEL TANK COVER/FUEL TANK](#).
35. Install new oil filter, engine oil and primary chaincase fluid as necessary.
36. See [Figure 3-33](#). Install right side rider footpeg bracket assembly. See [2.22 FOOTPEGS AND FOOTPEG SUPPORT BRACKETS](#).
37. Connect **both** battery cables, positive cable first. See [7.16 BATTERY](#).
38. Install seat. See [2.29 SEAT](#).

REMOVAL

Before removing the cylinder head assembly, see 3.3 STRIPPING MOTORCYCLE FOR ENGINE REPAIR/REMOVAL. The rocker arm covers and internal components must be removed before removing cylinder head.

1. See Figure 3-43. Remove screws with washers and fiber seals. Discard fiber seals.

CAUTION

Do not mix or replace hardened washers and fasteners with unhardened parts. Do not reuse fiber cover seals. These actions may result in accelerated wear and increased noise.

2. Remove rocker cover.
3. Remove and discard gaskets.
4. Rotate crankshaft until piston on head reaches top dead center of compression stroke.
5. Remove spark plug.

NOTE

Both valves in the cylinder head will be closed when viewed through the spark plug hole.

6. Remove the two rocker arm retaining bolts near the push rods.
7. Remove remaining hardware holding lower rocker cover to cylinder head in the following order.
 - a. Remove two screws and washers.
 - b. Remove three bolts and washers.
 - c. Remove the remaining two rocker arm retaining bolts.

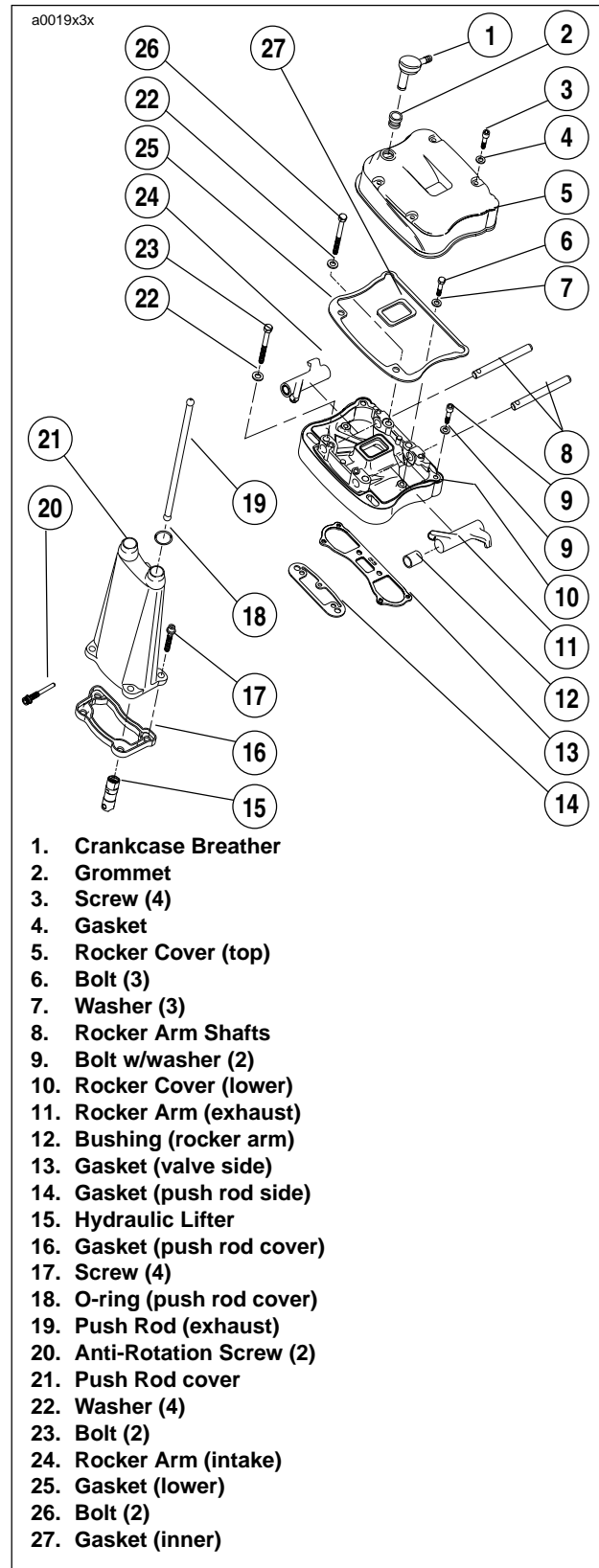

Figure 3-43. Rocker Arm Cover

- See Figure 3-43. Remove lower rocker cover.

NOTE

Remove lower rocker box as an assembly; then disassemble as required.

- Mark the location and orientation (top/bottom) of each push rod. Remove push rods.

CAUTION

Mark rocker arm shafts for reassembly in their original positions. Valve train components must be reinstalled in their original positions to prevent accelerated wear and increased valve train noise.

- See Figure 3-44. Remove rocker arm shafts by tapping them out using a hammer and a soft metal punch.
- See Figure 3-43. Remove rocker arms; **mark them for reassembly** in their original locations.

CAUTION

Distortion to the head, cylinder and crankcase studs may result if head screws are not loosened (or tightened) gradually in the sequence shown in Figure 3-45.

- See Figure 3-45. Loosen each head screw 1/8-turn following the sequence shown.
- Support motorcycle under crankcase. Do not allow engine to drop when performing the next Step.
- Continue loosening in 1/8-turn increments until screws are loose. Remove head screws.
- Remove cylinder head, head gasket, and O-rings.
- Discard head gasket.
- See Figure 3-43. Remove push rod cover, gasket and valve tappets.

DISASSEMBLY

- See Figure 3-46. Compress valve springs with VALVE SPRING COMPRESSOR (Part No. HD-34736B).
- See Figure 3-47. Remove valve keepers, upper collar and valve springs. Mark valve keepers for reassembly in their original locations.
- Use a fine tooth file to remove any burrs on the valve stem at the keeper groove.
- Mark valve to ensure that it will be reassembled in the same head. Remove valve, valve stem seal and lower collar.
- Repeat the above procedure for the other valve.

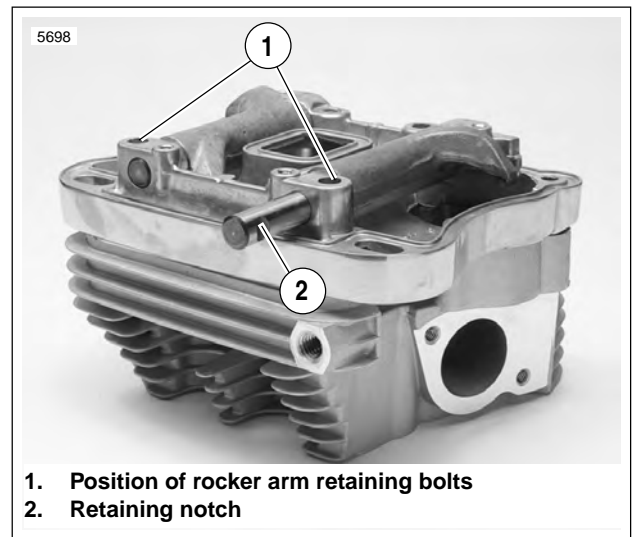

Figure 3-44. Removing Rocker Arm Shafts (Typical)

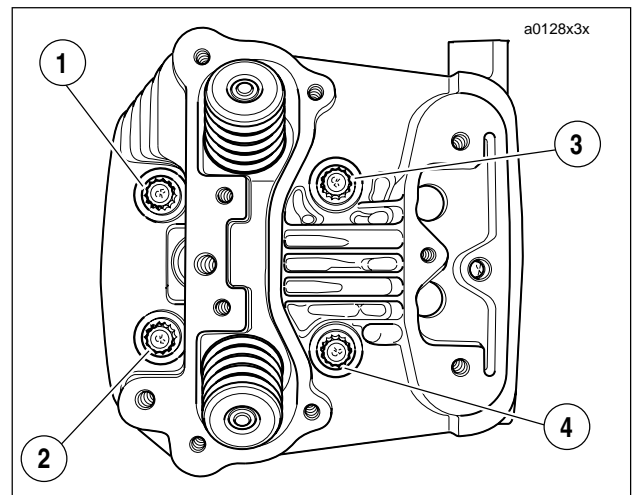

Figure 3-45. Head Screw Loosening/Tightening Sequence

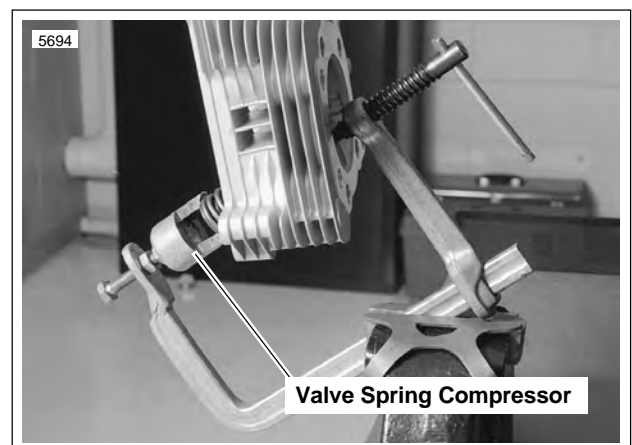
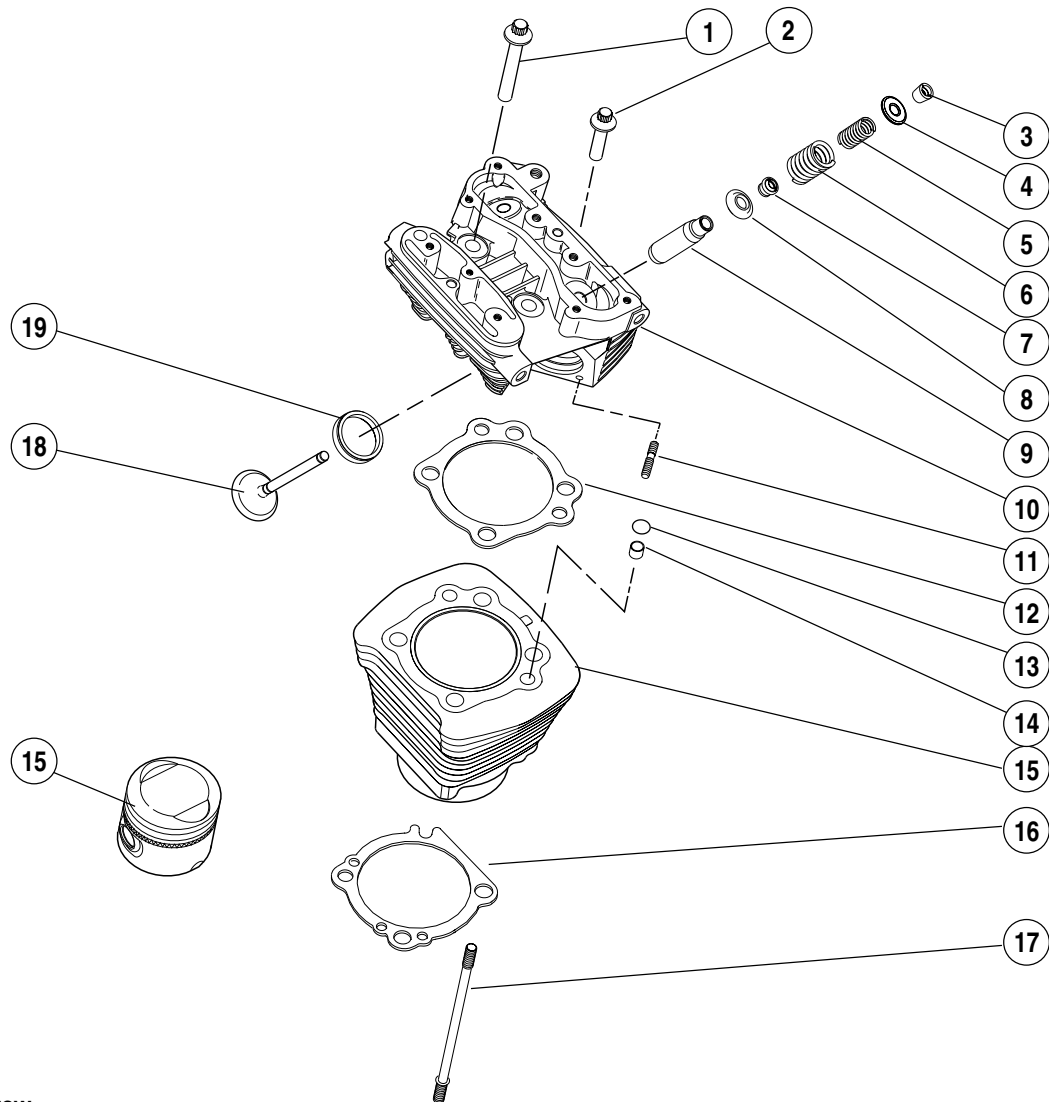

Figure 3-46. Valve Spring Compressor (Part No. HD-34736B)

a0021x3x



1. Screw
2. Screw
3. Valve collar retainer
4. Upper valve spring collar
5. Inner valve spring
6. Outer valve spring
7. Valve seal
8. Lower valve spring collar
9. Valve guide intake & exhaust (2)
10. Cylinder head
11. Exhaust port stud
12. Cylinder head gasket
13. Cylinder O-ring (4)
14. Cylinder insert
15. Cylinder w/piston & rings
16. Cylinder base gasket
17. Cylinder base stud
18. Exhaust valve
19. Exhaust valve seat

Figure 3-47. Cylinder Head, Cylinder and Piston Assembly

CLEANING AND INSPECTION

1. Bead blast or scrape carbon from head, top of cylinder and valve ports. Be careful to avoid scratching or nicking cylinder head and cylinder joint faces. Blow off loosened carbon or dirt with compressed air.
2. Soak cylinder head in an aluminum-compatible cleaner/solvent to loosen carbon deposits.
3. Wash all parts in non-flammable solvent, followed by a thorough washing with hot, soapy water. Blow out oil passages in head. Be sure they are free of sludge and carbon particles. Remove loosened carbon from valve head and stem using a wire wheel. Never use a file or other hardened tool which could scratch or nick valve. Polish valve stem with very fine emery cloth or steel wool.
4. Check each rocker arm, at pad end and push rod end, for uneven wear or pitting. Replace rocker arm if either condition exists.
5. Measure and record rocker arm shaft diameter.
 - a. See [Figure 3-48](#). Measure where shaft fits in lower rocker arm cover.
 - b. See [Figure 3-49](#). Measure where rocker arm bushings ride.
6. Measure and record rocker arm shaft bore diameter.
 - a. See [Figure 3-50](#). Measure bore of lower rocker cover.
 - b. See [Figure 3-51](#). Measure rocker arm bushing inner diameter.



Figure 3-48. Measuring Rocker Arm Shaft Diameter (Rocker Cover Position)



Figure 3-49. Measuring Rocker Arm Shaft Diameter (Rocker Arm Bushing Position)

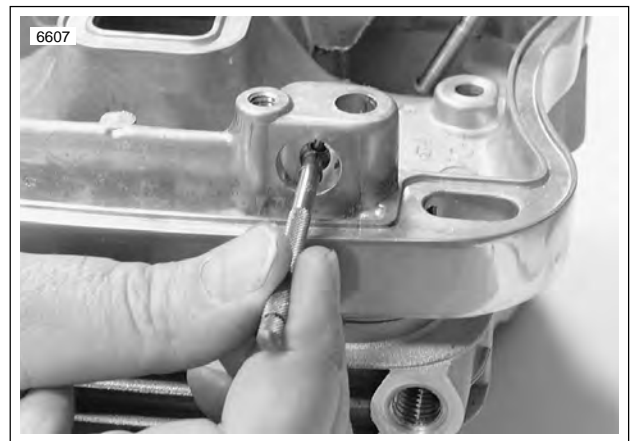

Figure 3-50. Measuring Rocker Arm Shaft Bore Diameter in Lower Rocker Cover

7. Check the measurements obtained in Steps 5-6 against the **SERVICE WEAR LIMITS**. Repair or replace parts exceeding limits.
8. Assemble rocker arms and rocker arm shafts into lower rocker cover.
9. Check end play of rocker arm with feeler gauge.
10. Replace rocker arm or lower cover or both if end play exceeds 0.025 in. (0.635 mm).
11. Valve heads should have a seating surface width of 0.040-0.062 in. (1.016-1.575 mm), and should be free of pit marks and burn spots. The color of carbon on exhaust valves should be black or dark brown. White or light buff carbon indicates excessive heat and burning.
12. Valve seats are also subject to wear, pitting, and burning. Resurface valve seats whenever valves are refinished.
13. Clean valve guides by lightly honing with VALVE GUIDE HONE (Part No. HD-34723).
14. Scrub guides with VALVE GUIDE BRUSH (Part No. HD-34751) and hot soapy water. Measure valve stem outer diameter and valve guide inner diameter. Check measurements against **SERVICE WEAR LIMITS**.
15. Inspect spark plug threads for damage. If threads in head are damaged, a special plug type insert can be installed using a 12 mm spark plug repair kit.
16. Inspect valve springs for broken or discolored coils.
17. See **Figure 3-52**. Check free length and compression force of each spring. Compare with **SERVICE WEAR LIMITS**. If spring length is shorter than specification or if spring compression force is below specification, replace spring.
18. Examine push rods, particularly the ball ends. Replace any rods that are bent, worn, discolored or broken.
19. See **Figure 3-53**. Check head gasket surface on head for flatness. Machine or replace any head which exceeds **SERVICE WEAR LIMIT** of 0.006 in. (0.152 mm).



Figure 3-51. Measuring Rocker Arm Bushing Inner Diameter

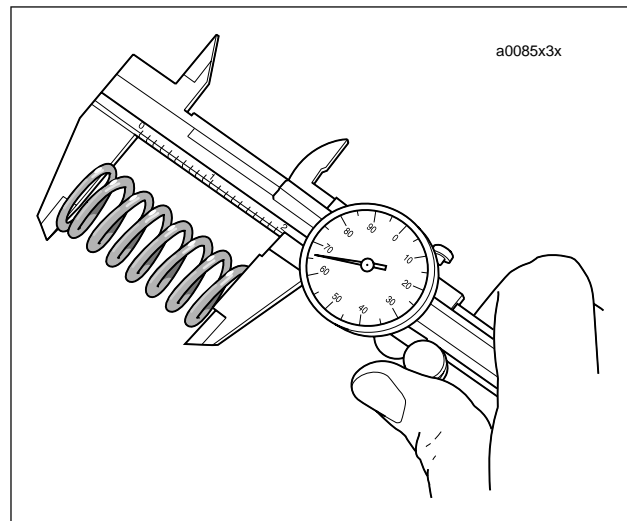

Figure 3-52. Checking Spring Free Length

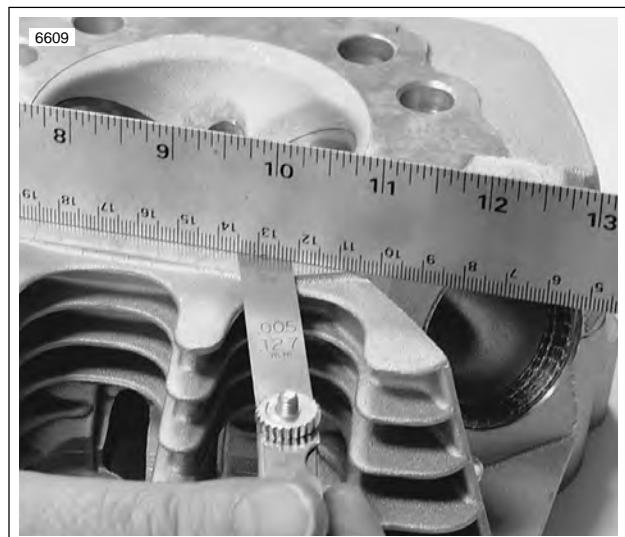

Figure 3-53. Checking Gasket Surface

Rocker Arms and Bushings

1. See Figure 3-54. To replace worn bushings, press or drive them from the rocker arm. If bushing is difficult to remove, turn a 9/16-18 tap into bushing. From opposite side of rocker arm, press out bushing and tap.
2. Press replacement bushing into rocker arm, flush with arm end, and split portion of bushing towards top of arm.
3. Using remaining old bushing as a pilot, line ream new bushing with ROCKER ARM BUSHING REAMER (Part No. HD-94804-57).
4. Repeat for other end of rocker arm.

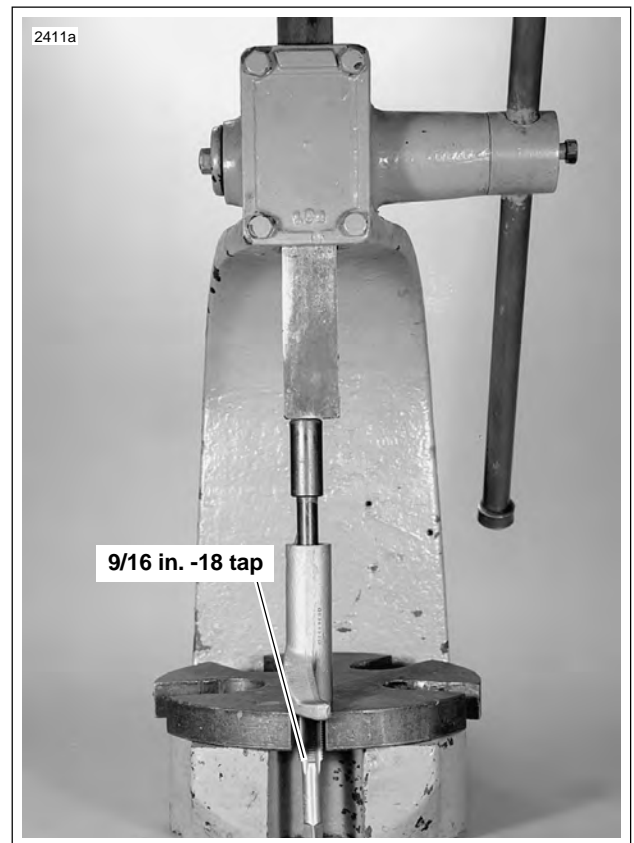

Figure 3-54. Removing Rocker Arm Bushing

Replacing Valve Guides

Valve guide replacement, if necessary, must be done before valve seat is ground. It is the valve stem hole in valve guide that determines seat grinding location. Valve stem-to-valve guide clearances are listed in [Table 3-5](#). If valve stems and/or guides are worn beyond limits, install **new** parts.

Table 3-5. Valve Stem Clearances and Service Wear Limits

VALVE	CLEARANCE	SERVICE WEAR LIMIT
Exhaust	0.0015-0.0033 in. (0.0381-0.0838 mm)	0.0040 in. (0.1016 mm)
Intake	0.008-0.0026 in. (0.203-0.0660 mm)	0.0035 in. (0.0889 mm)

- To remove shoulderless guides, press or tap guides toward combustion chamber using DRIVER HANDLE AND REMOVER (Part No. HD-34740).
- Clean and measure valve guide bore in head.
- Measure outer diameter of a new standard valve guide. The guide diameter should be 0.0020-0.0033 in. (0.0508-0.0838 mm), larger than bore in head. If it is not, select one of the following oversizes: +0.001 in. (+0.025 mm), +0.002 in. (+0.051 mm) or +0.003 in. (+0.076 mm) (intake and exhaust).
- See [Figure 3-55](#). Install shoulderless guides using VALVE GUIDE INSTALLATION TOOL (Part No. HD-34731) and DRIVER HANDLE (Part No. HD-34740). Press or drive guide until the tool touches the machined surface surrounding the guide. At this point, the correct guide height has been reached.
- Ream guides to final size or within 0.0010 in. (0.0254 mm) of final size using VALVE GUIDE REAMER (Steel, Part No. HD-39932 or Carbide, Part No. HD-39932-CAR). Use REAMER LUBRICANT (Part No. HD-39964) or liberal amounts of suitable cutting oil to prevent reamer chatter.

NOTE

The hone is not intended to remove material.

- Apply the proper surface finish to the valve guide bores using the VALVE GUIDE HONE (Part No. HD-34723). Lubricate hone with honing oil. Driving hone with an electric drill, work for a crosshatch pattern with an angle of approximately 60°.
- See [Figure 3-56](#). Thoroughly clean valve guide bores using VALVE GUIDE BRUSH (Part No. HD-34751) and hot soapy water.



Figure 3-55. Installing Shoulderless Valve Guide

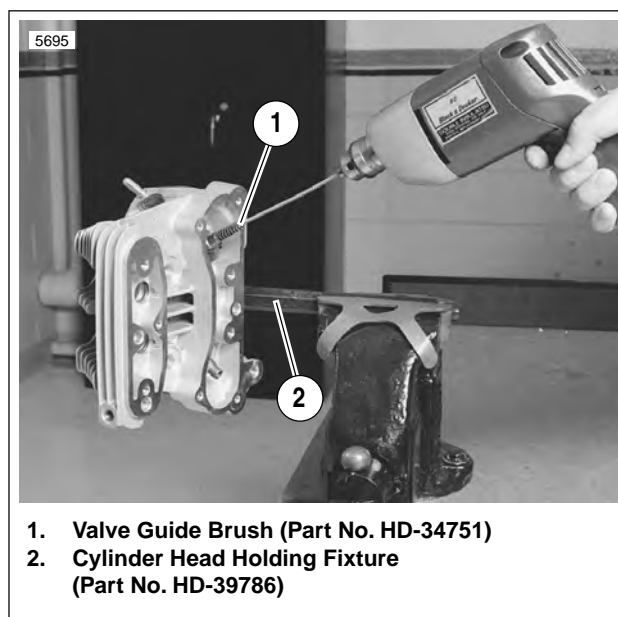

Figure 3-56. Cleaning Valve Guides

Grinding Valve Faces and Seats

After installing valve guides, reface valve seats to make them concentric with guides.

See [Figure 3-57](#). Valve face angle is 45° for both intake and exhaust valves. If a valve re-facing grinder is used, it must be adjusted exactly to this angle.

NOTES

- It is important to remove no more metal than is necessary to clean up and true valve face.
- Install a new valve if grinding leaves the valve edge (the margin) with a width of less than 1/32 in. (0.8 mm).

CAUTION

Do not use valves with too thin of margins. Using a valve with too thin a margin does not seat normally, burns easily, may cause pre-ignition and can also lead to valve cracking.

- Valves that do not clean up quickly are probably warped or too deeply pitted to be reused.
- Replace the valve if end of valve stem shows uneven wear.
- After valves have been ground, handle with care to prevent damage to the ground faces.

The valve seats may be refinished with cutters or grinders. Cut seats to a 46° angle or grind seats to a 45° angle.

See [Table 3-6](#). Valve seat tools and fixtures are available commercially. Seat each valve in the same position from which it was removed.

The correct 3-angle valve seat angles are as shown. Use NEWAY VALVE SEAT CUTTER SET (Part No. HD-35758) to cut the seats. Always grind valves before cutting seats.

- See [Figure 3-58](#). Cut 46° (or grind 45°) valve seat angle first. Use cutting oil to avoid chatter marks. Cut or grind only enough to clean up the seat.
- Apply a small amount of lapping compound to the valve face. Rotate valve against seat using VALVE LAPPING TOOL (Part No. HD-96550-36A).
- See [Figure 3-57](#). Check the contact pattern on valve face. It should be 0.040-0.062 in. (1.016-1.575 mm) wide, and its center should be positioned 2/3 of the way toward the outside edge of face.
- If valve seat pattern is too close to the stem side of valve face, cut a 60° angle in order to raise seat. If pattern is too close to the edge of valve face, cut a 31° angle in order to lower seat.
- After cutting either or both 31° or 60° angles to position seat, final cut 46° (or grind 45°) seat angle to obtain proper 0.040-0.062 in. (1.016-1.575 mm) width.
- Recheck valve seat width and location with lapping compound as described in Step 2.
- To achieve a smooth even finish, place a piece of 280 grit emery paper under the cutter head and rotate cutter.

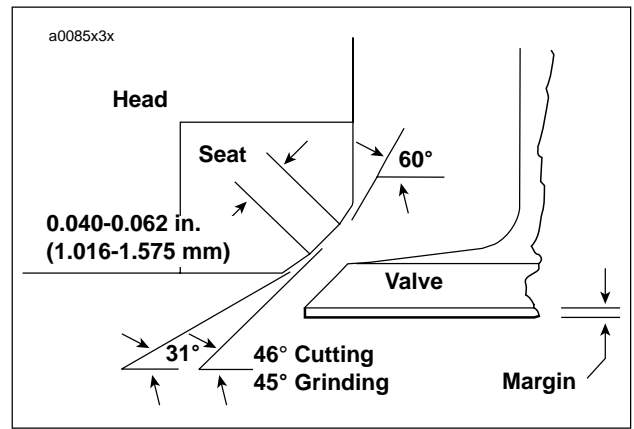

Figure 3-57. Valve Seat Angles

Table 3-6. Neway Valve Seat Cutters

VALVE SEAT	60° CUTTER	31° AND 46° CUTTERS
Exhaust	Part No. 205	Part No. 622
Intake	Part No. 293	Part No. 642

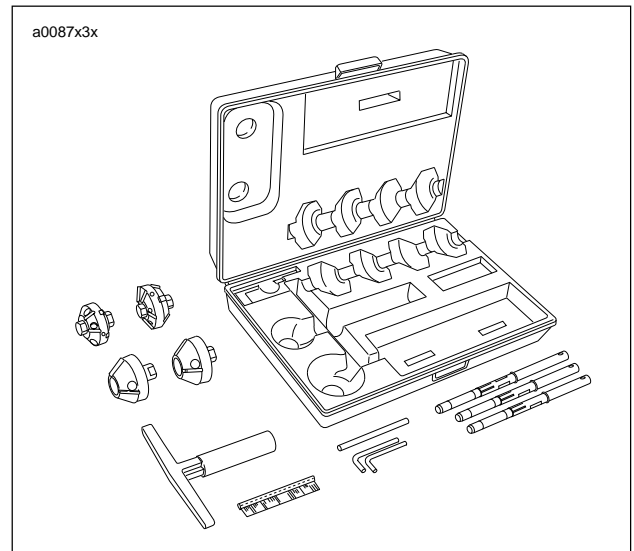

Figure 3-58. Valve Seat Cutter

CAUTION

Do not grind valve to shorten. Grinding will remove the case hardening and expose the stem's mild steel core resulting in rapid end wear.

- See [Figure 3-59](#). Wipe valve seats and valve faces clean. Measure valve stem protrusion.
 - If valve stem protrudes more than 2.031 in. (51.587 mm), replace valve seat or cylinder head.
 - If valve stem protrusion is acceptable, valves and seats are ready for lapping.

Replacing Valve Seats

Replacing a valve seat is a complex operation requiring special equipment. If the seat is loose or is not fully seated in the head, then seat movement will prevent the proper transfer of heat from the valve. The seat surface must be flush with (or below) the head surface. See 3.1 SPECIFICATIONS for valve seat-to-cylinder head fit.

To remove the old seat, lay a bead of weld material around the inside diameter of the seat. This will shrink the seat outside diameter and provide a surface for driving the seat out the port side.

Lapping Valve Faces and Seats

NOTE

If valve faces and seats have been smoothly and accurately refaced, very little lapping will be required to complete the seating operation.

1. See Figure 3-60. Use CYLINDER HEAD HOLDING FIXTURE (Part No. HD-39786) to secure cylinder head.
 - a. Apply a light coat of fine lapping compound to valve face. Insert valve in guide.
 - b. Place one rubber cup end of VALVE LAPPING TOOL (Part No. HD-96550-36A) onto head of valve.
 - c. Holding lapping tool as shown, apply only very light pressure against valve head.
 - d. Rotate lapping tool and valve alternately clockwise and counterclockwise a few times.
2. Lift valve and rotate it about 1/3 of a turn clockwise. Repeat lapping procedure in Step 1.
3. Repeat Step 2. Then, remove valve.
4. Wash valve face and seat. Dry parts with a **new**, clean cloth or towel.
5. Inspect valve and seat.
 - a. If inspection shows an unbroken lapped finish of uniform width around both valve and seat, valve is well seated.
 - b. If lapped finish is not complete, further lapping (or grinding and lapping) is necessary.



Figure 3-59. Measuring Valve Stem Protrusion



Figure 3-60. Lapping Valves

ASSEMBLY

CAUTION

Make sure all lapping compound is removed from cylinder head and valves after lapping is completed. If lapping compound contaminates any internal engine components or engine oil, excessive engine wear and damage may result.

1. Wash cylinder head and valves in warm, soapy water to remove all lapping compound.
2. Scrub valve guide bores with VALVE GUIDE BRUSH (Part No. HD-34751) and hot, soapy water.
3. Blow dry with compressed air.
4. Apply a liberal amount of engine oil to the valve stem.
5. See Figure 3-61. Insert valve into valve guide and install lower collar.
6. See Figure 3-62. Place a protective sleeve over the valve stem keeper groove. Coat the sleeve with oil and place a new seal over the valve stem.

CAUTION

- Always use a protective sleeve on the valve stem keeper groove when installing valve stem seal. If the seal is installed without using the protective sleeve, the seal will be damaged.
 - Do not remove valve after seal is installed. Otherwise, sharp edges on keeper groove will damage seal.
7. See Figure 3-61. Tap the valve stem seal onto the valve guide using the VALVE SEAL INSTALLATION TOOL (Part No. HD-34643A) and DRIVER HANDLE (Part No. HD-34740). The seal is completely installed when the tool touches the lower collar.
 8. See Figure 3-62. Install valve springs and upper collar.
 9. Compress springs with VALVE SPRING COMPRESSOR (Part No. HD-34736B).
 10. Insert valve keepers into upper collar, making sure they engage groove in valve stem. The keeper gaps should be equal.
 11. Release and remove VALVE SPRING COMPRESSOR.
 12. Repeat Steps 4-11 for the remaining valve.

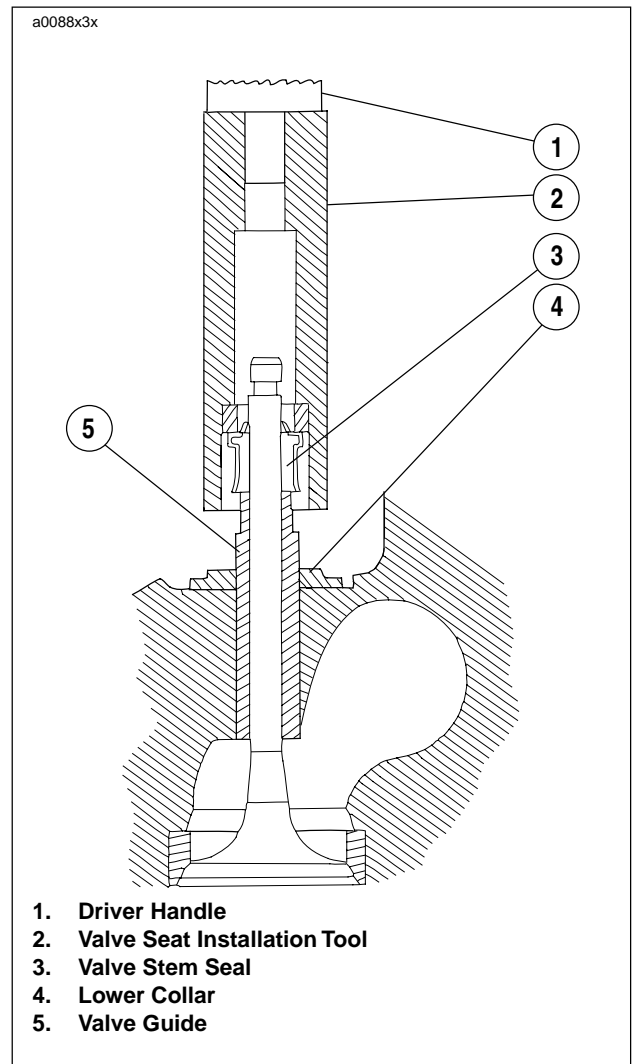

Figure 3-61. Valve Seal Installation

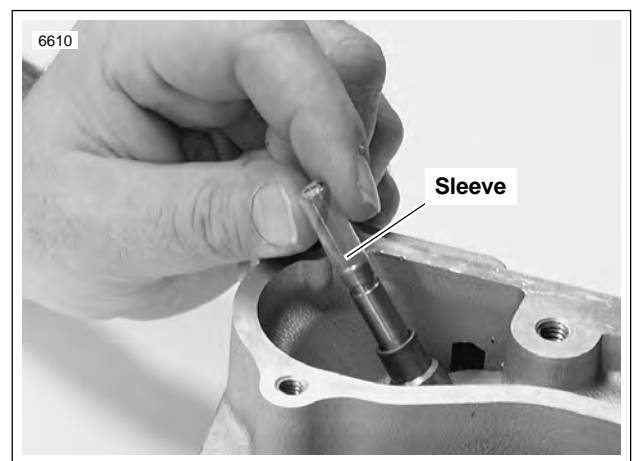

Figure 3-62. Valve Guide Seal Protector Sleeve

INSTALLATION

If only cylinder head work was needed, reinstall cylinder head following these instructions. If further repair is required, see [3.6 CYLINDER AND PISTON](#).

1. Coat mating surfaces of cylinder studs and head screws with parts cleaning solution.
2. Scrape old oil and any carbon deposits from threads by using a back-and-forth motion, threading each head screw onto its mating cylinder stud.
3. Remove head screws from studs. Wipe or blow dry thread surfaces.
4. Apply oil to stud threads and to the underside of the head screw shoulder.

CAUTION

Only oil film must remain on the head screw surfaces. Too much oil will pool in the head screw sleeve. Pooled oil may prevent proper torque application and full thread engagement.

5. Blow or wipe off excess oil from head screws.
6. Thoroughly clean and dry the gasket surfaces of cylinder and cylinder head.
7. Install a **new** O-ring on each dowel.

CAUTION

O-rings help to properly position the head gasket. O-rings must be installed before the head gasket.

8. Install a **new** head gasket to cylinder.
9. Carefully lower cylinder head over studs and position on dowels. Use great care so as not to disturb head gasket.

CAUTION

The procedure for tightening the head screws is critical to proper distribution of pressure over gasket area. It prevents gasket leaks, stud failure, and head and cylinder distortion.

10. See [Figure 3-45](#). For each cylinder head, start with screw numbered one, as shown. In increasing numerical sequence (i.e. – 1, 2, 3 and 4):
 - a. Tighten bolts to 13-15 ft-lbs (17.6-20 Nm).
 - b. Loosen all screws.
11. After screws are loosened from initial torque, tighten head screws in three stages. Tighten fasteners in increasing numerical sequence (i.e. – 1, 2, 3 and 4).
 - a. Tighten each screw to 7-9 ft-lbs (9.5-12.2 Nm).
 - b. Tighten each screw to 12-14 ft-lbs (16.3-19.0 Nm).
 - c. See [Figure 3-63](#). Mark cylinder head and head screw shoulder with a line as shown (View A).
 - d. Turn all bolts an additional 85° -95° .
12. See [3.15 HYDRAULIC LIFTERS](#). Install hydraulic lifters and push rod cover.
13. See [Figure 3-64](#). See [Table 3-7](#). Identify push rod color coding, length and respective push rod positions in engine. Place intake and exhaust push rods onto seat at top of tappet.

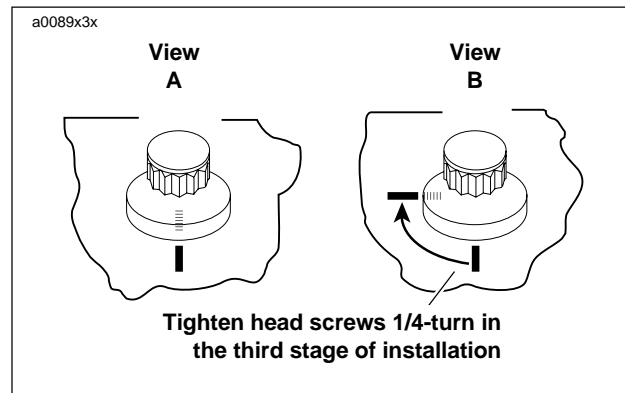

Figure 3-63. Tightening Head Screws

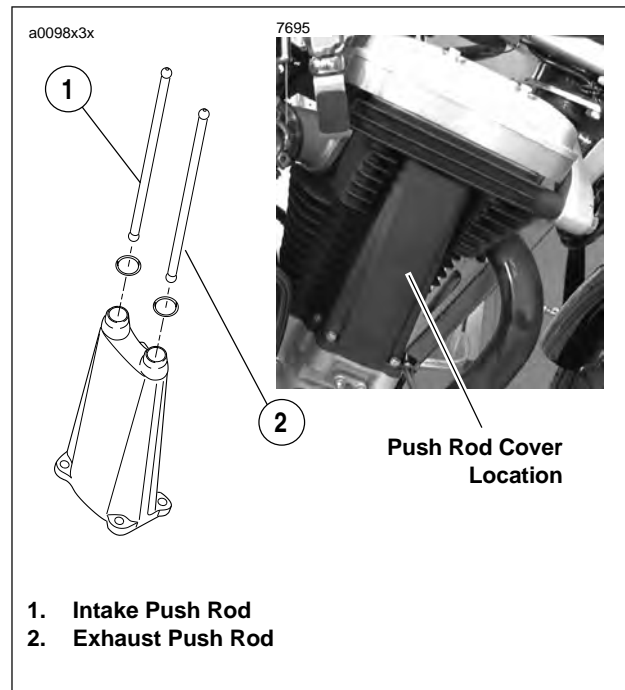

Figure 3-64. Push Rod Locations

Table 3-7. Push Rod Selection

Position	Color Code	Length	Part Number
Exhaust	1 Band-Black	10.800 in. (274.320 mm)	17895-00Y
Intake	1 Band-Orange	10.746 in. (272.948 mm)	17984-00Y

14. See [Figure 3-65](#). Install **new** gaskets with the bead facing up. Place lower rocker box assembly (with rocker arms and shafts into position). Place push rods in rocker arm sockets.

CAUTION

Do not turn engine over until both push rods can be turned with fingers. Otherwise, damage to push rods or rocker arms may result.

15. See [Figure 3-66](#). Install fasteners. Slowly snug all fasteners in small increments (one turn at a time). Use a cross pattern on the four large bolts) that fasten the lower rocker box to head. This will bleed the tappets. Fastener sizes and torque specifications are listed in [Table 3-8](#).
- Tighten bolts to 15-19 ft-lbs (20.3-26 Nm).
 - Tighten bolts to 10-14 ft-lbs (13.6-19 Nm).
 - Tighten bolts to 130-150 **in-lbs** (14.7-17.9 Nm).
16. See [Figure 3-65](#). Install upper rocker covers.
- Place a **new** inner gasket on lower rocker box assembly.
 - Place a **new lower** gasket on lower rocker cover.
 - Install upper rocker cover using screws with washers and **new** fiber seals. Tighten screws to 10-14 ft-lbs (13.6-9 Nm).

Table 3-8. Lower Rocker Box Hardware

ITEM	SIZE	TORQUE
Bolt with washer (12)	5/16-18 X 2-3/4	15-19 ft-lbs (20.3-26 Nm)
Bolt with washer (13)	5/16-18 X 2-1/2	
Screw with washer (14)	1/4-20 X 1-1/2	130-150 in-lbs (14.7-17.9 Nm)
Bolt with washer (15)	1/4-20 X 1-1/4	10-14 ft-lbs (13.6-19 Nm)

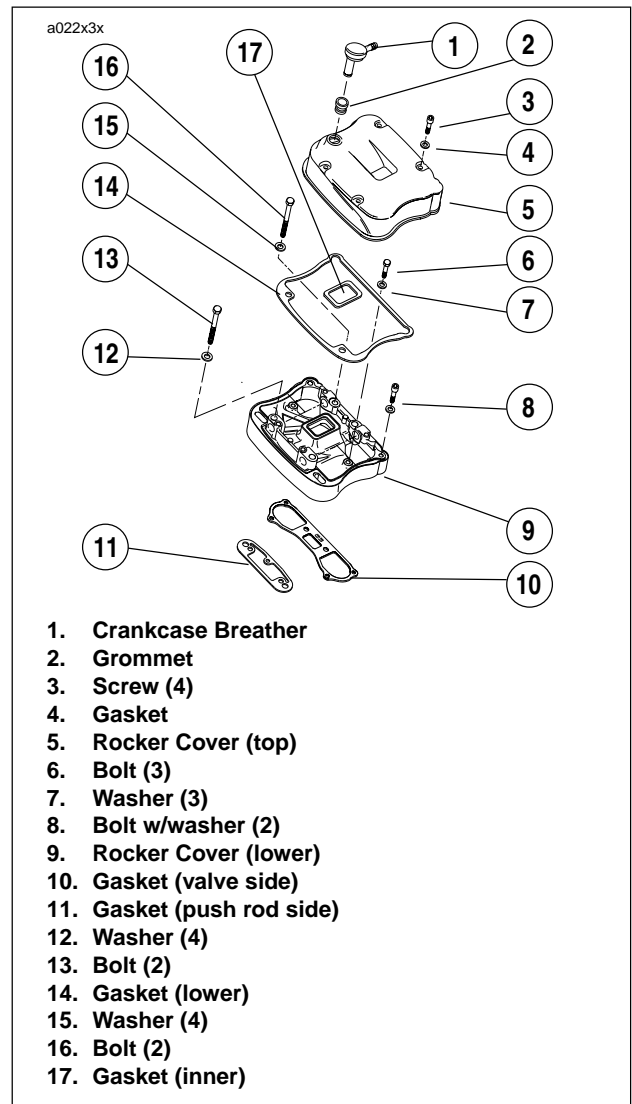

Figure 3-65. Rocker Arm Cover Gaskets

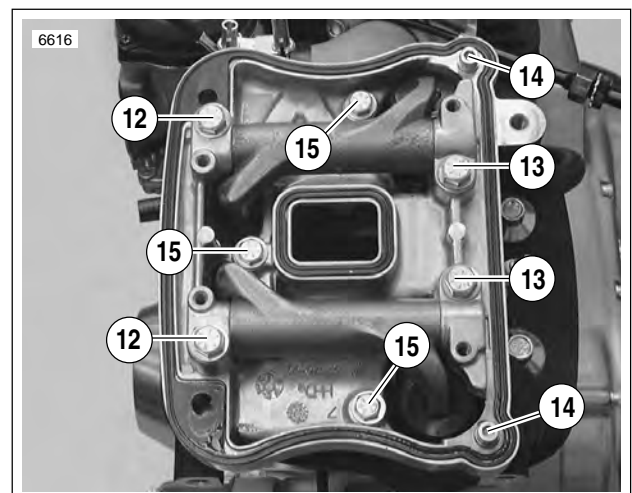

Figure 3-66. Lower Rocker Box Fasteners

REMOVAL/DISASSEMBLY

1. See 3.3 STRIPPING MOTORCYCLE FOR ENGINE REPAIR/REMOVAL. Strip motorcycle as described under this procedure.
2. Remove cylinder head. See 3.5 CYLINDER HEAD.
3. Clean crankcase around cylinder base to prevent dirt and debris from entering crankcase while removing cylinder.
4. See Figure 3-67. Turn engine over until piston of cylinder being removed is at bottom of its stroke.
5. Carefully raise cylinder just enough to permit placing clean towel under piston to prevent any foreign matter from falling into crankcase.

NOTE

- If cylinder does not come loose, lightly tap a plastic hammer perpendicular to the cylinder fins. Never try to pry a cylinder up.
6. Carefully lift cylinder over piston and cylinder studs. Do not allow piston to fall against cylinder studs. Discard cylinder base gasket.

CAUTION

With cylinder removed, be careful not to bend the cylinder studs. The slightest bend could cause a stress riser and lead to stud failure.

7. Install a 6.0 in. (152 mm) length of 1/2 in. (12.7 mm) ID plastic or rubber hose over each cylinder stud. This will protect the studs and the piston.

WARNING

Retaining rings are highly compressed in the ring groove and may “fly out” with considerable force when pried out. Always wear safety glasses or goggles when removing or installing retaining rings. Failure to wear safety glasses or goggles could result in death or serious injury.

CAUTION

DO NOT re-use piston pin retaining rings. Removal may weaken retaining rings and they may break or dislodge if reinstalled resulting in engine damage.

8. Insert an awl in the recessed area below the piston pin bore and pry out the piston pin retaining rings. To prevent the ring from flying out, place your thumb over the retaining ring.

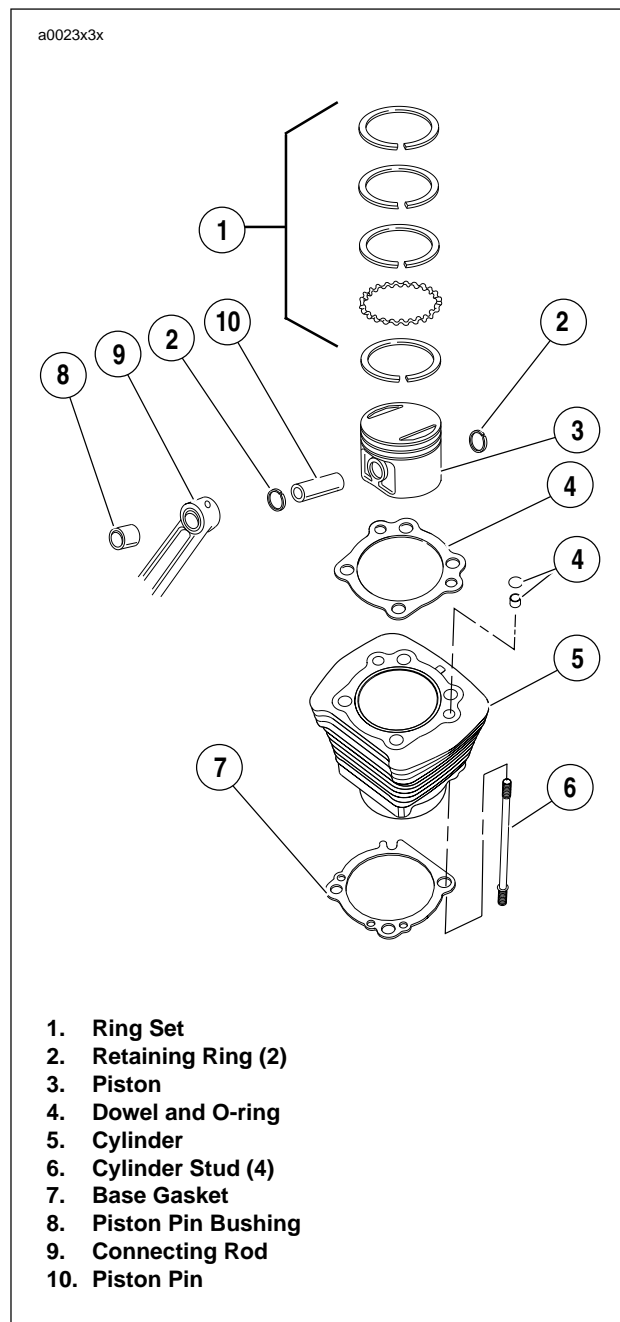

Figure 3-67. Cylinder and Piston

NOTE

Since the piston pin is a loose fit in the piston, the pin will easily slide out. The pin has tapered ends to help seat the round retaining rings.

- See Figure 3-68. The arrow at the top of pistons must always point toward the front of the engine.

CAUTION

Handle the piston with extreme care. The alloy used in these pistons is very hard. Any scratches, gouges or other marks in the piston could score the cylinder during engine operation and cause engine damage.

- See Figure 3-68. Spread piston rings outward until they clear grooves in piston and lift off.

CLEANING AND INSPECTION

- Soak cylinder and piston in an aluminum-compatible cleaner/solvent until deposits are soft, then clean with a brush. Blow off loosened carbon and dirt particles and wash in solvent.
- Clean oil passage in cylinder with compressed air.
- Clean piston ring grooves with a piece of compression ring ground to a chisel shape.
- Examine piston pin to see that it is not pitted or scored.
- Check piston pin bushing to see that it is not loose in connecting rod, grooved, pitted or scored.
 - A piston pin properly fitted to upper connecting rod bushing has a 0.00125 to 0.00175 in. (0.03175-0.04445 mm) clearance in bushing.
 - See Connecting Rod Bushing section. If piston pin-to-bushing clearance exceeds 0.00200 in. (0.05080 mm), replace worn parts.
- Clean piston pin retaining ring grooves.
- Examine piston and cylinder for cracks, burnt spots, grooves and gouges.
- Check connecting rod for up and down play in lower bearings. When up and down play is detected, lower bearing should be refitted. This requires removing and disassembling engine crankcase.

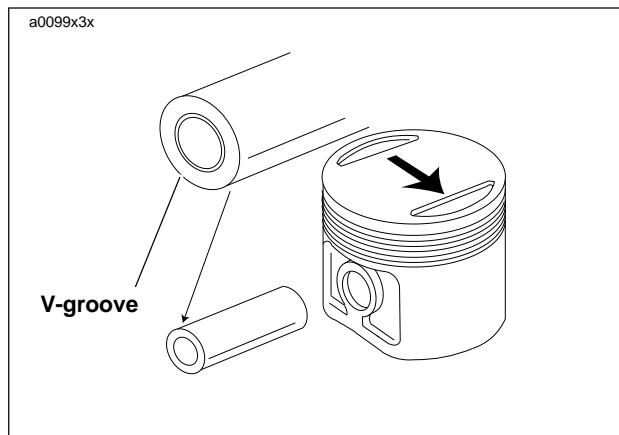

Figure 3-68. Piston Pin and Piston Identification

Checking Gasket Surface

CAUTION

If cylinder gasket surface does not meet flatness specifications, replace cylinder and piston. Proper tolerances will extend component life and prevent leaks.

- See Figure 3-69. Check cylinder head gasket surface for flatness.
 - Lay a straightedge across the surface.
 - Try to insert a feeler gauge between the straight-edge and the gasket surface.
 - If cylinder head gasket surface is not flat within 0.006 in. (0.152 mm), replace cylinder and piston.
- Check cylinder base gasket surface for flatness.
 - Lay a straightedge across the surface.
 - Try to insert a feeler gauge between the straight-edge and the gasket surface.
 - If cylinder base gasket surface is not flat within 0.008 in. (0.203 mm), replace cylinder and piston.

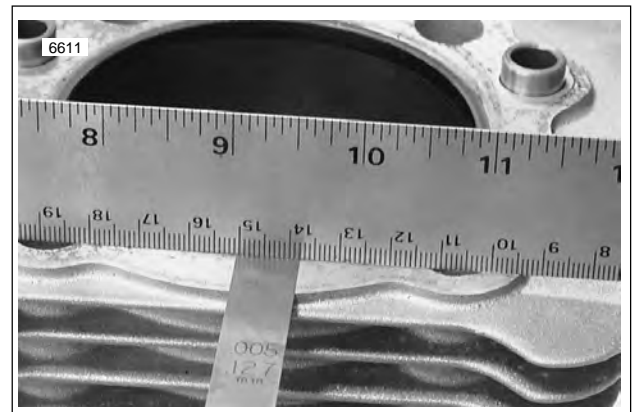

Figure 3-69. Checking Gasket Surfaces

Measuring Cylinder Bore

1. Remove any burrs from the cylinder gasket surfaces.
2. See 3.5 CYLINDER HEAD. See Figure 3-70. Install a head and base gasket, and CYLINDER TORQUE PLATES (Part No. HD-33446A) and XL EVOLUTION TORQUE PLATE BOLTS (Part No. HD-33446-86). Tighten the bolts using the same method used when installing the cylinder head screws.

NOTE

Torque plates, properly tightened and installed with gaskets, simulate engine operating conditions. Measurements will vary as much as 0.001 in. (0.025 mm) without torque plates.

3. Take cylinder bore measurement in ring path, starting about 1/2 in. (12.7 mm) from top of cylinder, measuring from front to rear and then side to side. Record readings.
4. Repeat measurement at center and then at bottom of ring path. Record readings. This process will determine if cylinder is out-of-round (or "egged") and will also show any cylinder taper or bulge.
5. See Table 3-9. If cylinder is not scuffed or scored and is within service limit, see FITTING CYLINDER TO PISTON section.

NOTE

See 3.1 SPECIFICATIONS. If piston clearance exceeds service wear limit, cylinders should be re-bored and/or honed to next standard oversize, and refitted with the corresponding piston and rings. Do not fit piston tighter than 0.0007 in. (0.0178 mm).

Measuring Piston

Because of their complex shape, the pistons cannot be accurately measured with standard measuring instruments.

Pistons have an elliptical shape when viewed from the top and are barrel-shaped when viewed from the side. This barrel shape is not symmetrical.

Any damage to the piston will change its shape, which will lead to problems.

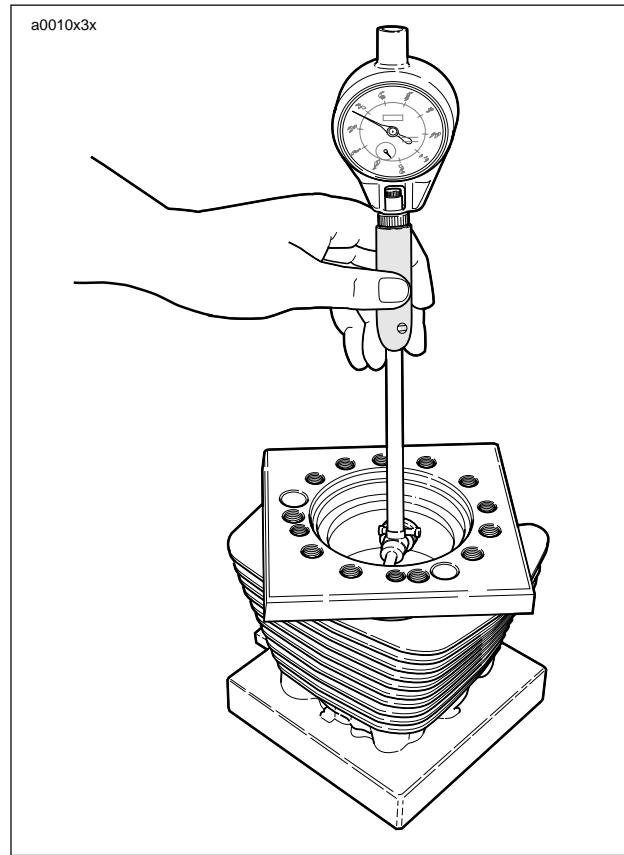

Figure 3-70. Measuring Cylinder Bore Using Torque Plates (Part No. HD-33446A)

Table 3-9. Cylinder Bore Service Wear Limits

BORE SIZES	IN.	MM
Standard Bore	3.5008	88.9203
0.005 in. OS bore (0.127 mm)	3.5050	89.0270
0.010 in. OS bore (0.254 mm)	3.5100	89.1540
0.020 in. OS bore (0.508 mm)	3.5200	89.4080
0.030 in. OS bore (0.762 mm)	3.5300	89.6620

Fitting Cylinder to Piston

Since pistons cannot be accurately measured with standard measuring instruments, the bore sizes must be measured. Bore sizes are listed in [Table 3-10](#). Example: A 0.005 in. (0.127 mm) oversize piston will have the proper clearance with a bore size of 3.502 in. \pm 0.0002 in. (88.951 mm \pm 0.0051 mm).

Boring and Honing Cylinder

When cylinder requires oversize reboring to beyond 0.030 in. (0.762 mm), the oversize limit has been exceeded and cylinder must be replaced.

1. Bore cylinder with gaskets and torque plates attached. Bore to 0.003 in. (0.076 mm) under the desired finished size.
- 2.hone the cylinder to its finished size using a 280 grit rigid hone followed by a 240 grit flexible ball hone. Honing must be done with the torque plates attached. All honing must be done from the bottom (crankcase) end of the cylinder. Work for a 60° crosshatch pattern.

Fitting Piston Rings

See [Figure 3-71](#). Piston rings are of two types: compression and oil control. The two compression rings are positioned in the two upper piston ring grooves. The dot on the second compression ring must face upward. Ring sets are available to fit standard and oversize pistons.

Piston ring sets must be properly fitted to piston and cylinder:

1. See [3.1 SPECIFICATIONS](#). See [Figure 3-72](#). Place piston in cylinder about 1/2 in. (12.7 mm) from top. Set ring to be checked squarely against piston as shown. Check end gap with thickness gauge.

NOTE

See [SERVICE WEAR LIMITS](#) for end gap dimensions. Do not file rings to obtain proper gap.

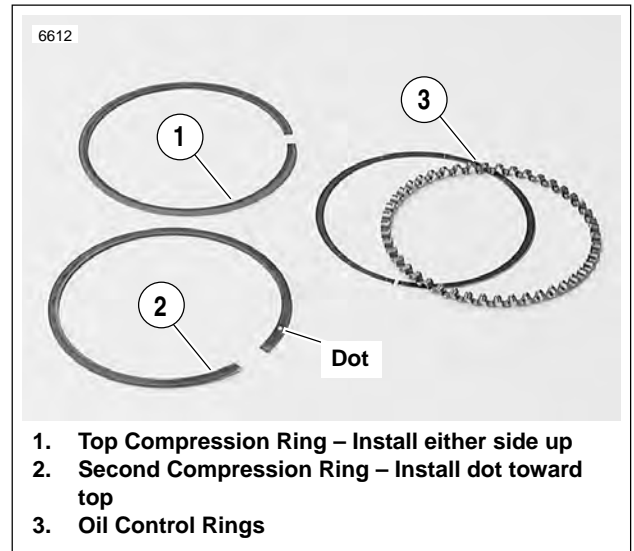

1. Top Compression Ring – Install either side up
2. Second Compression Ring – Install dot toward top
3. Oil Control Rings

Figure 3-71. Piston Rings

Table 3-10. Final Cylinder Bore Sizes

BORE SIZES	IN.	MM
Standard bore*	3.4978 in.	88.8441 mm
0.005 in. OS bore (0.127 mm)	3.502 in.	88.951 mm
0.010 in. OS bore (0.254 mm)	3.507 in.	89.078 mm
0.020 in. OS bore (0.508 mm)	3.517 in.	89.332 mm
0.030 in. OS bore (0.762 mm)	3.527 in.	89.586 mm

*All bore sizes + 0.0002 in. (0.0051 mm)

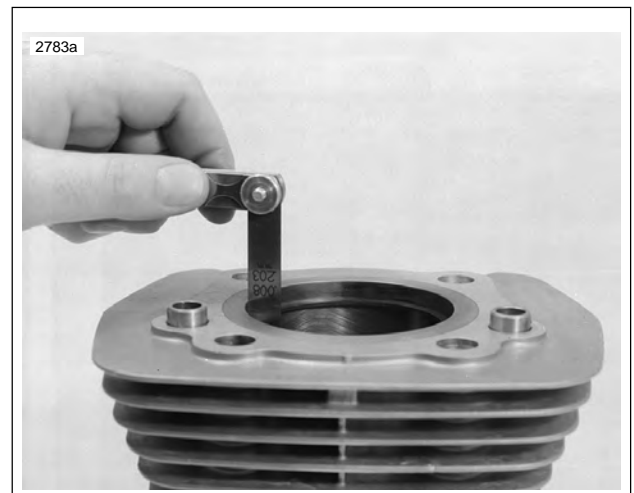

Figure 3-72. Measuring Ring End Gap

NOTE

The same piston may be used if cylinder bore was not changed, unless it is scuffed or grooved. If re-using piston, replace piston rings and hone the cylinder walls with a No. 240 grit flexible hone to facilitate ring seating.

- See Figure 3-73. Apply engine oil to piston grooves. Use TRANSMISSION SHAFT RETAINING RING PLIERS (Part No. J-5586) to slip compression rings over piston into their respective grooves. Be extremely careful not to over expand, twist rings or damage piston surface when installing rings.

NOTE

Install second compression ring with dot towards top.

- See Figure 3-74. Install rings so end gaps of adjacent rings are a minimum of 90° apart. Ring gaps are not to be within 10° of the thrust face centerline.
- See 3.1 SPECIFICATIONS. See Figure 3-75. Check for proper side clearance with thickness gauge, as shown.

NOTE

If the ring grooves are clean and the side play is still not correct, replace the rings, the piston or both.

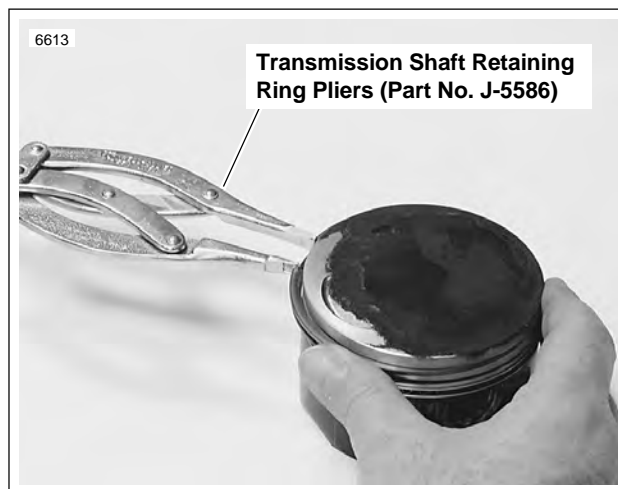

Figure 3-73. Installing Piston Rings

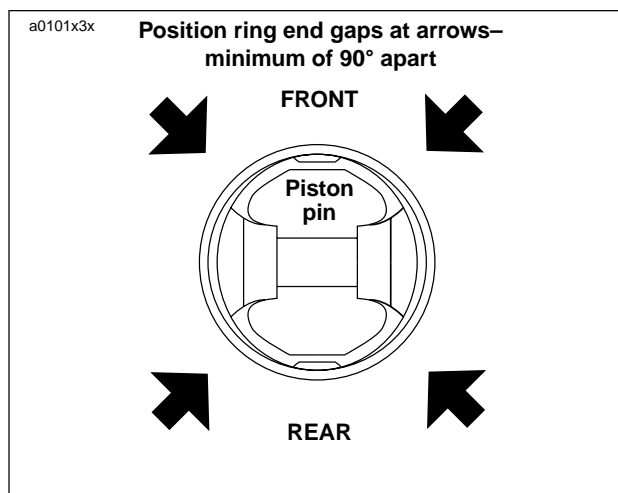

Figure 3-74. Ring End Gap Position

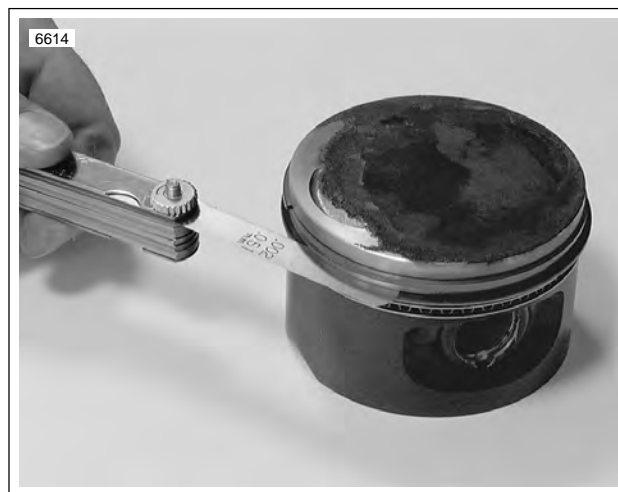

Figure 3-75. Measuring Ring Clearance in Groove

Connecting Rod Bushing

REMOVAL/INSTALLATION

When connecting rod bushing is worn to excessive pin clearance (0.002 in. or more) (0.051 mm) it must be replaced.

1. Secure connecting rod with CONNECTING ROD CLAMPING TOOL (Part No. HD-95952-33B).
2. See Figure 3-77. Attach PISTON PIN BUSHING TOOL (Part No. HD-95970-32D) to the connecting rod. The receiver cup fits on one side of the rod while the driver fits on the opposite side as shown.
3. Use two box wrenches and push worn bushing from connecting rod.
4. Remove piston pin bushing tool from connecting rod.
5. Remove bushing from receiver cup.
6. Place **new** bushing between connecting rod and driver.

NOTE

The driver must be attached facing the opposite direction as it was for removal of the bushing.

7. Clean up and size bushing to 0.0010-0.0005 in. (0.0254-0.0127 mm) undersize using REAMER (Part No. HD-94800-26A). Sizing bushing with less than 0.00125 in. (0.03175 mm) clearance can result in a bushing loosening and/or seized pin in rod.
8. Hone bushing to final size using WRIST PIN BUSHING HONE (Part No. HD-35102). Use a liberal amount of honing oil to prevent damage to hone or bushing. Use care to prevent foreign material from falling into the crankcase.

CAUTION

Replace bent connecting rods. Do not attempt to straighten. Straightening rods by bending will damage the bearing on the crank pin and the piston pin bushing. Installing bent connecting rods will damage cylinder and piston beyond repair.

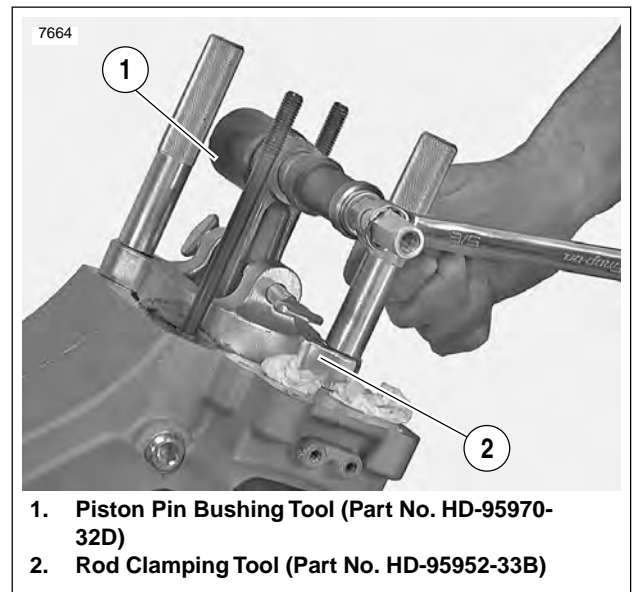

1. Piston Pin Bushing Tool (Part No. HD-95970-32D)
2. Rod Clamping Tool (Part No. HD-95952-33B)

Figure 3-76. Installing New Piston Pin Bushing

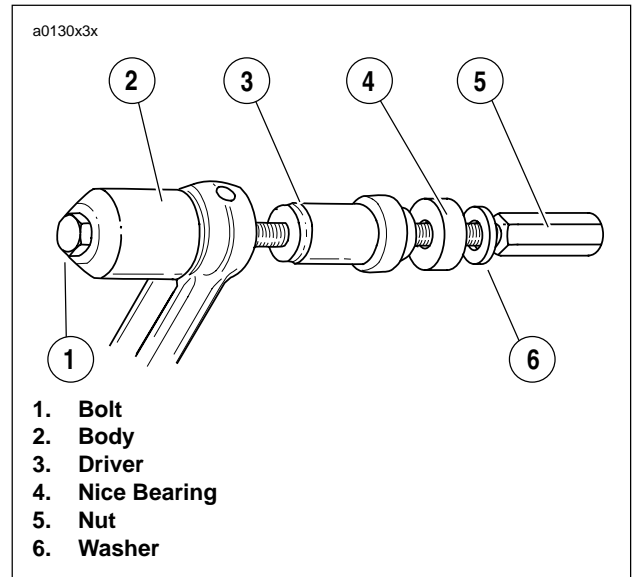

1. Bolt
2. Body
3. Driver
4. Nice Bearing
5. Nut
6. Washer

Figure 3-77. Piston Pin Bushing Tool Assembly for Bushing Removal

ASSEMBLY/INSTALLATION

1. See [Figure 3-78](#). Place PISTON SUPPORT PLATE (Part No. HD-42322) in position as shown.
2. Install piston assembly over connecting rod.

NOTE

Piston must be installed with the arrow, at the top of the piston, pointing towards the front of the engine.

3. Install piston pin.

CAUTION

Always use new retaining ring. Make sure retaining ring groove is clean and that ring seats firmly in groove. If it does not, discard the ring. Never install a used retaining ring or a new one if it has been installed and then removed for any reason. A loosely installed ring will come out of the piston groove and damage cylinder and piston beyond repair.

4. See [Figure 3-79](#). Install **new** piston pin retaining rings (1) using PISTON PIN RETAINING RING INSTALLER (2) (Part No. HD-34623B). Place **new** retaining ring on tool with gap pointing up. See [Figure 3-80](#).

NOTE

Make sure the ring groove is clean. Ring must be fully seated in the groove with the gap away from the slot at the bottom.

5. See [Figure 3-74](#). Make sure the piston ring end gaps are properly positioned as shown.



Figure 3-78. Piston Support Plate

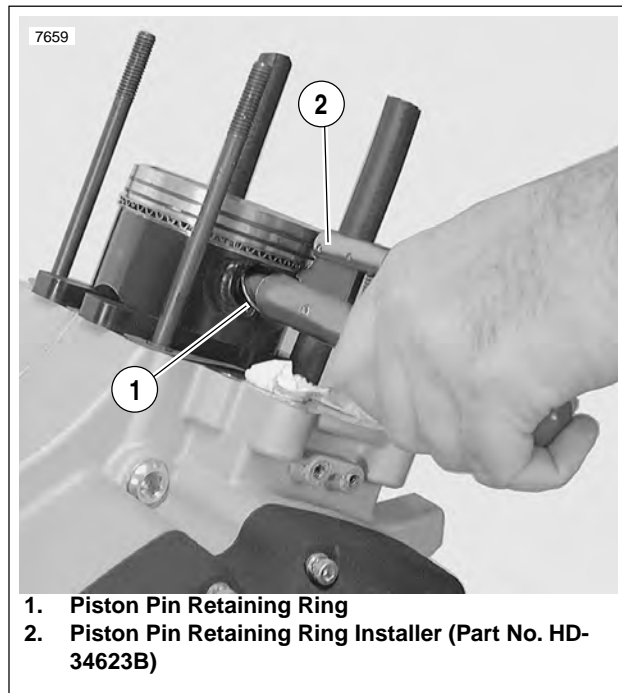

1. Piston Pin Retaining Ring
2. Piston Pin Retaining Ring Installer (Part No. HD-34623B)

Figure 3-79. Installing Piston Retaining Rings

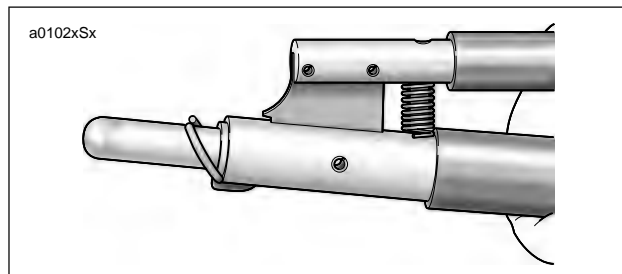

Figure 3-80. Installing Retaining Ring

6. See [Figure 3-81](#). Turn engine until piston is resting on top of PISTON SUPPORT PLATE (Part No. HD-42322) top dead center.
7. Lubricate cylinder wall, piston, pin and rod bushing with engine oil.
8. See [Figure 3-82](#). Compress the piston rings using PISTON RING COMPRESSOR (Part No. HD-96333-51C).
9. Remove protective sleeves from cylinder studs. Install a **new** cylinder base gasket. Make sure the piston does not bump the studs or crankcase.
10. Install cylinder over piston.
11. Remove PISTON RING COMPRESSOR.
12. Assemble cylinder head. See [3.5 CYLINDER HEAD](#).
13. Install cylinder head. See [3.5 CYLINDER HEAD](#).
14. Install assembled engine. See [3.4 ENGINE INSTALLATION](#).



Figure 3-81. Piston Support Plate

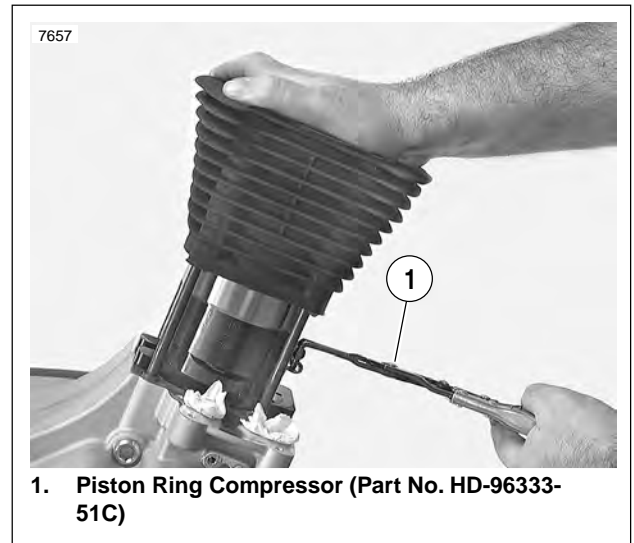

Figure 3-82. Compressing Piston Rings

NOTES

CHECKING AND ADDING OIL

Check engine oil level in oil reservoir at least once every 500 miles (800 km). Check level more frequently if engine uses more oil than normal or if vehicle is operated under harsh conditions. Check oil when engine is warmed up to operating temperature (see Hot Check).

CHANGING OIL AND FILTER

After a new engine has run its first 1000 miles (1600 km) and at 5000 mile (8000 km) intervals or annually thereafter, completely drain oil reservoir of used oil. If riding habits include severe dust conditions, operation at temperature above 80 ° F, extensive idling, speeds in excess of 65 m.p.h. and /or extensive two up riding or similar loads the oil should be changed at 2,500 mile (4000 km) intervals. Refill with fresh oil. Always change oil filter when changing engine oil.

NOTE

See [1.5 ENGINE LUBRICATION SYSTEM](#) for more information on checking oil level and changing oil and filter.

WINTER LUBRICATION

Normal fuel combustion in a gasoline engine produces water vapor and carbon dioxide along with other gases and particulates. When first starting and warming an engine, some of the water vapor that gets into the engine crankcase condenses to form liquid water. If the engine is driven long enough to thoroughly warm the crankcase, most of this liquid water is again vaporized and exhausted through the crankcase breather system.

A moderately driven vehicle making short runs may not be able to vacate water vapors allowing liquid water to accumulate in the oil reservoir. This is especially true if the vehicle is operated in cold weather. In freezing weather, an accumulation of water in the engine oil may become slush or ice, which can block oil lines and lead to severe engine damage. Water remaining in the engine oil for long periods of time can form an acidic sludge that is corrosive to metal engine parts and causes accelerated wear of moving components.

In winter the oil change interval should be shorter than normal. The colder the weather, the shorter the recommended oil change interval. A vehicle used only for short runs in cold weather must have the engine oil drained frequently.

GENERAL

See [Figure 3-83](#). Engine oil runs through the frame backbone which serves as the oil reservoir. From the bottom of the reservoir, the vent hose and the return hose run downward below the battery tray. A rubberized clamp secure the hoses in place.

See [Figure 3-83](#). A T-fitting on the bottom left side of the oil reservoir, supplies the feed hose and the oil drain hose. See [Figure 3-84](#). The drain hose attaches to the left side of the footpeg support bracket frame.

See [Figure 3-85](#). The feed and return hoses run together alongside the engine and forward to the oil pump. The feed hose attaches to the rear most oil pump fitting; the return hose connects forward and above.

See [Figure 3-86](#). After diverging from the feed and return hoses, the vent hose continues on to the right side of the motorcycle. Here the vent hose connects to an elbow fitting on the gearcase cover.

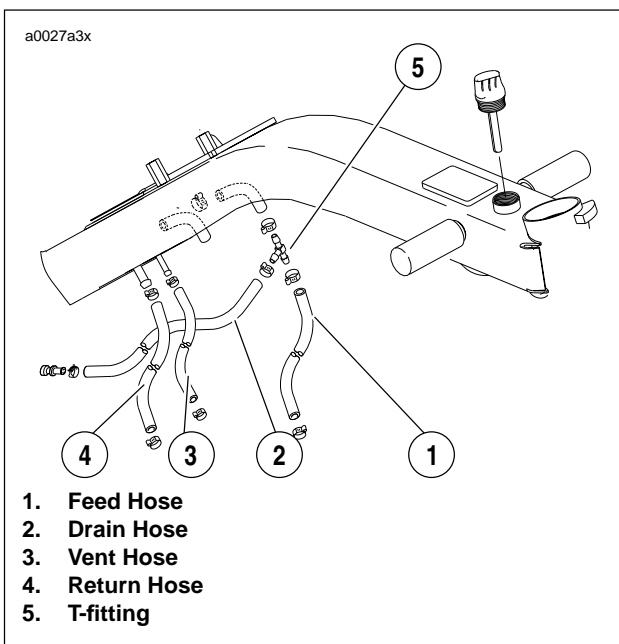

Figure 3-83. Oil Reservoir Hose Assembly

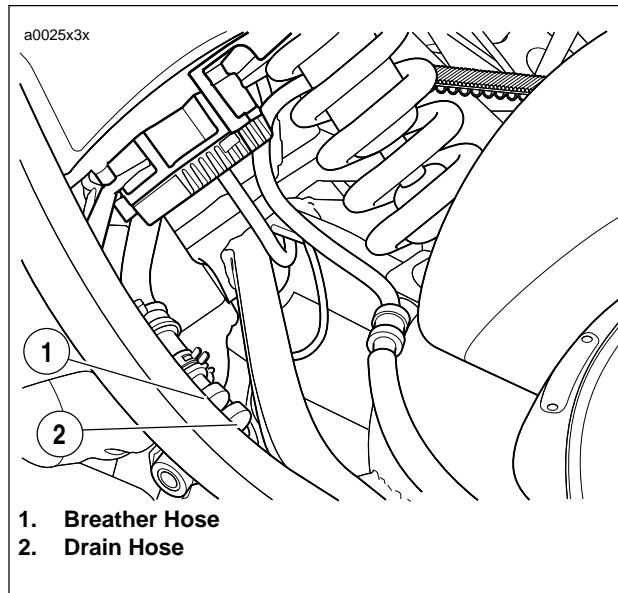

Figure 3-84. Drain Hose

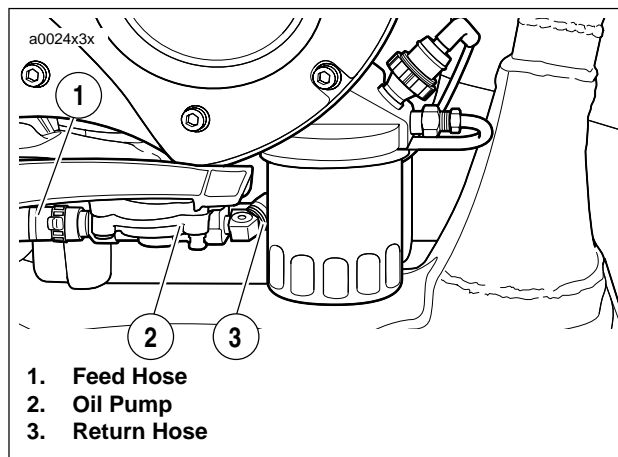

Figure 3-85. Oil Pump Connections

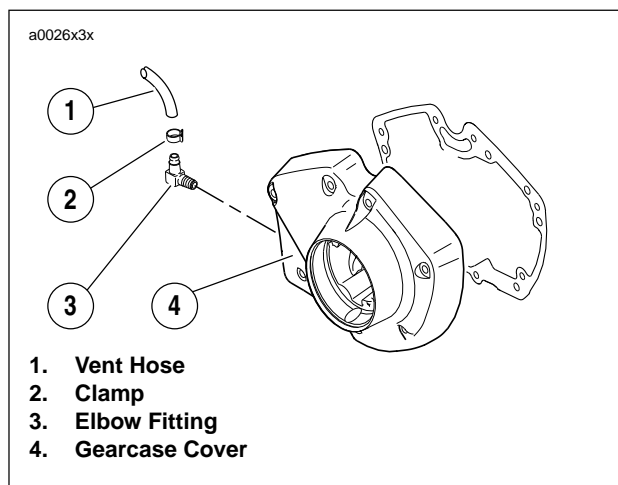

Figure 3-86. Vent Hose Connection

GENERAL

See [Figure 3-87](#). Engine oil is stored in the frame backbone which acts as an oil reservoir. From the bottom of the reservoir, the vent hose and the return hose run downward below the battery tray. A rubberized clamp secure the hoses in place.

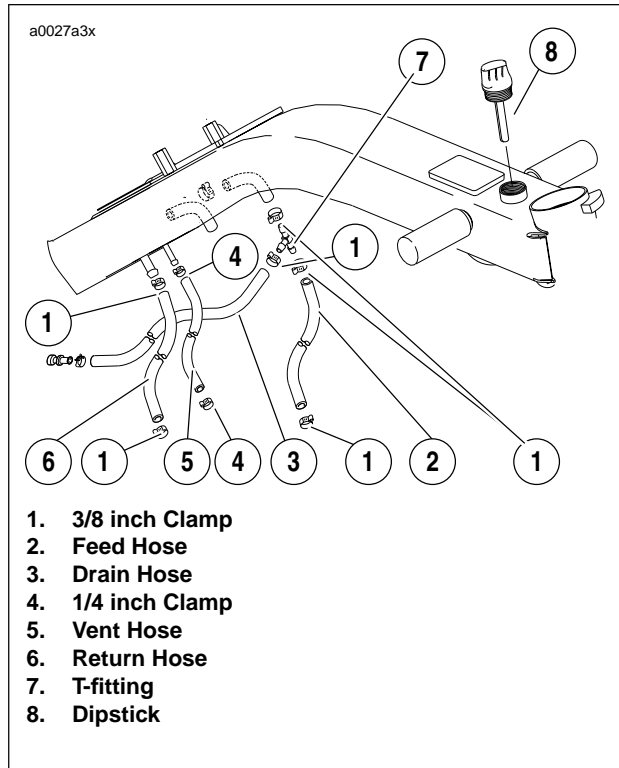

Figure 3-87. Oil Reservoir (Frame Backbone)

GENERAL

The oil pressure indicator switch is a pressure-actuated diaphragm-type switch. When oil is not circulating through the system or when oil pressure is low, spring tension holds the switch contacts closed, thereby completing the signal light circuit and causing the indicator lamp to illuminate.

OIL PRESSURE SIGNAL LIGHT

The oil pressure signal light turns ON when:

- Ignition switch is turned on prior to starting engine.
- Oil is not circulating through the running engine.
- Oil pressure is abnormally low in the running engine.
- Engine is idling below 1000 RPM.

The oil pressure signal light turns OFF when:

- Oil is circulating with adequate pressure through the engine running at 1000 RPM or greater.

Troubleshooting information is listed in [Table 3-11](#).

NOTE

If the ignition is turned back on immediately after the engine is stopped, the oil light may not turn on right away because of oil pressure retained in the filter housing.

OIL PRESSURE

See [Figure 3-88](#). The oil pump is non regulatory and delivers its entire volume of oil under pressure to the oil filter mount. When an engine is cold, the engine oil will be more viscous (i.e., thicker).

When an engine is operated at high speeds, the volume of oil circulated through the oiling system increases, resulting in higher oil pressure. As engine speed is reduced, the volume of oil pumped is also reduced, resulting in lower oil pressure.

To check oil pressure, use OIL PRESSURE GAUGE (Part No. HD-96921-52B) and OIL PRESSURE GAUGE ADAPTER (Part No. HD-96940-58). Remove oil pressure indicator switch and insert pressure gauge fitting.

Ride motorcycle at least 20 miles (32 km) at or above 50 MPH (80 KM/H) until engine oil reaches normal operating temperature. At 2500 RPM, oil pressure will vary from 10-12 psi (69-83 KPa). At idle speed (950-1050 RPM), oil pressure will vary from 6-8 psi (42-55 KPa).



Figure 3-88. Oil Pressure Indicator Switch

Table 3-11. Troubleshooting Oil Pressure Signal Light

OIL PRESSURE SIGNAL LIGHT	PROBABLE CAUSES
Stays on at speeds above idle.	<ul style="list-style-type: none"> ● Empty oil reservoir. ● Clogged feed line (ice and sludge, freezing temperatures). ● Air-bound oil line. ● Grounded oil switch wire. ● Malfunctioning signal switch. ● Diluted oil. ● Malfunctioning check valve (see 3.14 OIL FILTER MOUNT).
Flickers at idle.	<ul style="list-style-type: none"> ● Incorrect idle speed. Malfunctioning or improperly installed check valve (see 3.14 OIL FILTER MOUNT).
Does not glow when ignition is turned on (prior to operating engine).	<ul style="list-style-type: none"> ● Malfunctioning signal switch. ● Malfunction in wiring. ● Burned-out signal bulb. ● Dead battery (see NOTE).

GENERAL

See Figure 3-89. On piston downstroke, a mixture of crankcase air and oil mist is vented up the push rod covers to the upper rocker box. Air is allowed to escape the rocker box by exiting the positive crankcase vent valve located on top of the rocker box.

The oil mist collects and eventually returns to the crankcase through oil passageways in the cylinder head.

The crankcase air passes through the breather assembly to the positive crankcase vent valve (PCV) located on top of the rocker box cover. From the PCV the air enters the crankcase breather hose. The crankcase breather hose splits with one hose (crankcase breather hose) going to the air cleaner and the other hose (crankcase breather drain hose) going to the footrest support bracket. Crankcase air is routed to the air cleaner box where it is directed into the carburetor's venturi. Any residual oil drains to the crankcase breather drain hose located behind the right footrest support (located by the oil tank drain hose). The crankcase breather drain hose should be drained at each oil change.

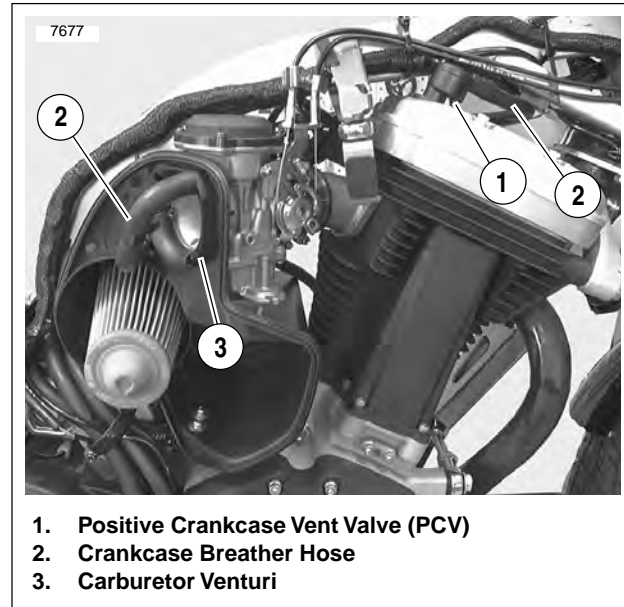

Figure 3-89. Crankcase Breathing System,

GENERAL

1. Oil is gravity-fed from the oil reservoir to the gerotor-style oil pump through a **feed hose**. Oil enters the **feed section** and fills a cavity located under the feed pump.

NOTE

See 3.13 *OIL PUMP* for a complete explanation of the gerotor pump sets.

2. The feed pump transfers oil from the inlet cavity through the **external steel line** to the oil filter mount.
3. Oil flows through the **filter mount cavity** to the oil filter.
4. Oil enters the peripheral cavity of the **oil filter**, passes through the filtering medium into the central cavity of the oil filter, and flows into the filter adapter (fitting which connects filter to filter mount).
5. Adequate oil pressure in the filter mount cavity activates the **oil pressure signal light switch** and shuts off the oil pressure signal light.
6. Oil flowing from the filter adapter opens the **check ball**. The check ball opens at 4-6 psi (28-41 kPa) oil pressure.
7. With the check ball open, oil flows into the **crankcase feed galley**.
8. Oil flows through the feed galley in the crankcase to the tappet blocks and hydraulic lifters. **Cross-drilled passages** intersect the main feed galley and carry oil to both hydraulic lifters.
9. Oil also enters an **intersecting passage** in the gearcase cover. Oil flow is then routed to the crankshaft area.
10. Oil enters a hole in the end of the **pinion gear shaft** and travels to the right flywheel where it is routed through the flywheel to the **crankpin**. Oil is forced through the crankpin to properly lubricate the rod bearing assembly.
11. Oil flows up passages in the **push rods** to the rocker arm shafts and bushings.
12. The valve stems are lubricated by oil supplied through drilled oil holes in the **rocker arms**.
13. Oil collected in the push rod areas of the cylinder heads flows down the **push rod cover**, through drain holes in the **tappet blocks** and into the gearcase. After providing lubrication to the gearcase components, the oil flows to the left side of the oil pump.
14. Feed oil to the rocker area is returned to the crankcase through a **passage** in the head and cylinder.
15. Oil collected in the **sump** is splash-fed to the pistons, cylinder walls and flywheel components.
16. A single piston oil jet cools the bottom of the piston with a spray of oil.
17. Oil collected in the sump area returns to the scavenge section of the oil pump through a **passage** located in the rear section of the sump. Oil flow to the pump is accomplished by the scavenging effect of the pump and by the pressure created by the downward stroke of the pistons.
18. Return oil fills a **cavity** above the pump's return gears. The return gears pump oil back to the oil reservoir.

GENERAL

See Figure 3-90. The oil pump consists of two gerotor gear sets, feed and return, housed in one pump body. The feed set distributes oil to the engine, the scavenge set returns oil to the tank/frame reservoir.

A gerotor-type gear set has two parts — an inner and an outer gerotor. The inner gerotor has one less tooth than the outer gerotor. Both gerotors have fixed centers which are off-set to each other.

In a gerotor gear set, oil is transferred from inlet to outlet as it is trapped between the rotating inner and outer gerotors.

See Figure 3-90. Gravity-fed oil from the oil reservoir enters the pump through the feed hose connector. It is forced by the gerotor feed set through a hose to the oil filter. Return oil from the flywheel compartment is drawn back into the pump and is forced by the gerotor scavenge set back to the oil reservoir.

The oil pump seldom needs servicing. Before you disassemble an oil pump suspected of not producing adequate oil pressure, be sure that all possible related malfunctions have been eliminated:

1. Make sure all oil hose clamps are tight and that hoses are not pinched or damaged.
2. Check level and condition of oil in tank. Pressure will be affected if oil is diluted. In freezing weather, proper circulation of oil can be affected if the oil feed hose becomes clogged with ice or sludge.
3. Check for a grounded oil pressure switch wire or faulty switch if oil indicator light fails to go out with engine running.

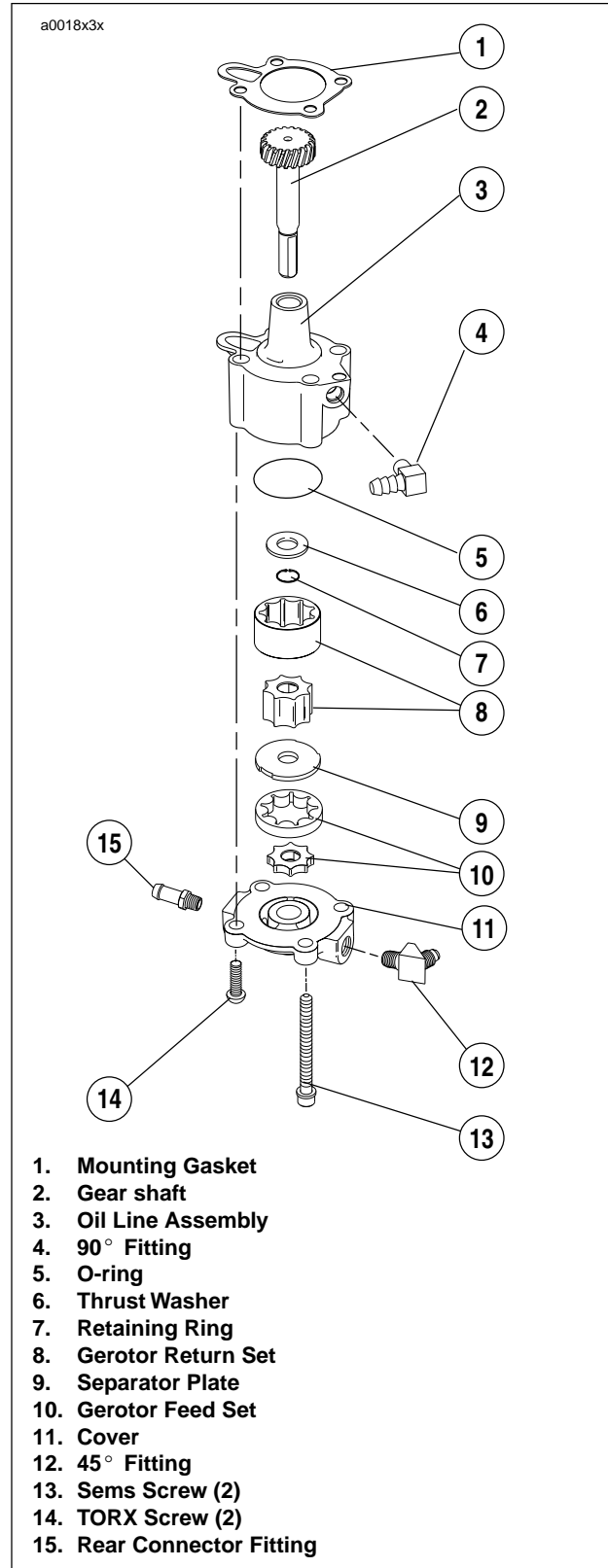

Figure 3-90. Oil Pump

REMOVAL/DISASSEMBLY

NOTE

Oil pump can be removed with engine in frame and without removing gearcase cover.

1. See ENGINE LUBRICATION SYSTEM section. Drain oil reservoir.
2. Remove and discard oil filter.
3. See Figure 3-91. Disconnect feed hose and oil filter hose connection.

NOTE

Loosen nut on oil filter hose connection and then remove pressurized hose.

4. Carefully remove mounting screws and washers only. Pump will drop with screws removed. Discard mounting gasket.
5. Remove clamp and detach return hose connection.
6. See Figure 3-91. Remove cover TORX screws. Lift cover off body.
7. Remove and discard O-ring.
8. See Figure 3-90. Slide both pieces of gerotor feed set, separator plate and both pieces of gerotor scavenge set off gear shaft.
9. Remove and discard retaining ring. Remove thrust washer and gear shaft.

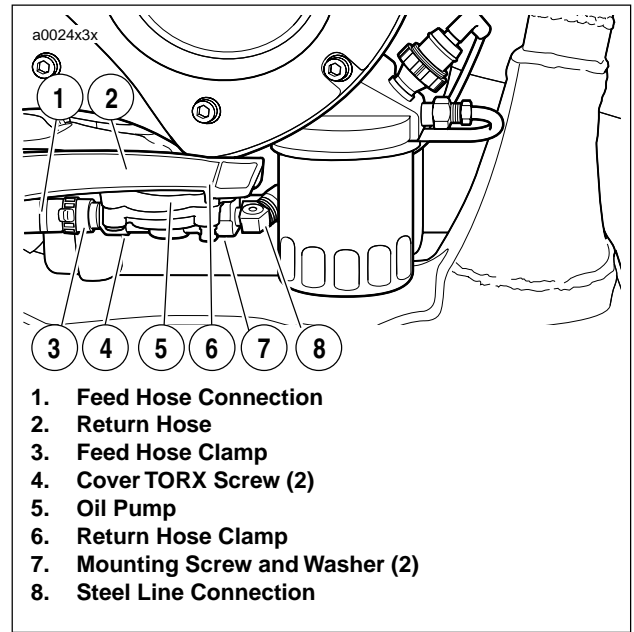

Figure 3-91. Oil Pump Hardware

CLEANING AND INSPECTION

1. Clean all parts in cleaning solvent. Blow out holes and oil passages with compressed air.
2. See Figure 3-92. Inspect both gerotor sets for wear.
 - a. Mesh pieces of each set together as shown.
 - b. Use a feeler gauge to determine clearance.
 - c. The SERVICE WEAR LIMIT between gerotors is 0.004 in. (0.102 mm). Replace gerotors as a set if clearance exceeds this dimension.
 - d. Measure thickness of feed gerotors with a micrometer. Replace gerotors as a set if they are not the same thickness.
3. See Figure 3-93. Check gear shaft teeth for damage or wear. Replace if necessary.

ASSEMBLY/INSTALLATION

NOTE

Liberalily coat all moving parts with clean engine oil to ensure easy assembly and smooth operation at start-up.

1. See Figure 3-90. Install gear shaft through body. Position thrust washer over end of shaft. Install **new** retaining ring into groove in shaft.
2. Insert inner gerotor of the gerotor scavenge set over gear shaft.
3. Place outer gerotor over inner gerotor to complete scavenge set.
4. See Figure 3-93. Install gerotor separator plate by lining up slots on perimeter with tabs inside oil pump body.
5. Install a **new** O-ring into groove in pump body.
6. See Figure 3-90. Place gerotor feed set over gear shaft.
7. Place cover onto pump body. Install cover TORX screws. Tighten to 125-150 **in-lbs** (14.1-16.9 Nm).
8. Place **new** mounting gasket in position.

NOTE

*Use **new** hose clamps. If fittings were removed, use TEFLON® PIPE SEALANT or HYLOMAR® on fitting threads.*

9. See Figure 3-91. Attach return hose connection.
10. Secure pump to crankcase with mounting screws. Tighten to 125-150 **in-lbs** (14.1-16.9 Nm).
11. Attach feed hose and oil filter hose connection.
12. Attach clamp to hose.
13. Install **new** oil filter. See 1.5 ENGINE LUBRICATION SYSTEM.
14. See 1.5 ENGINE LUBRICATION SYSTEM. Check engine oil level. Add oil to correct level if needed.

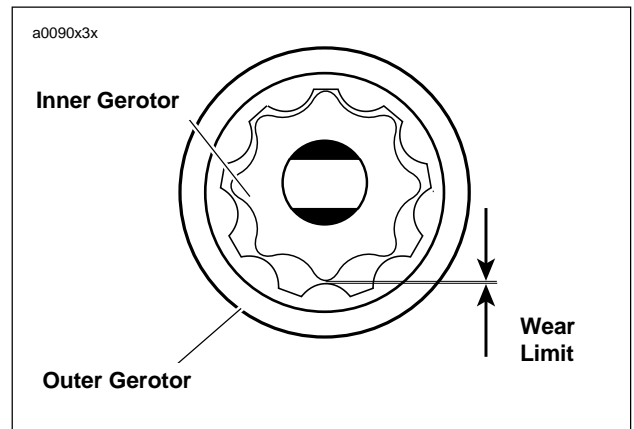

Figure 3-92. Gerotor Wear Limits

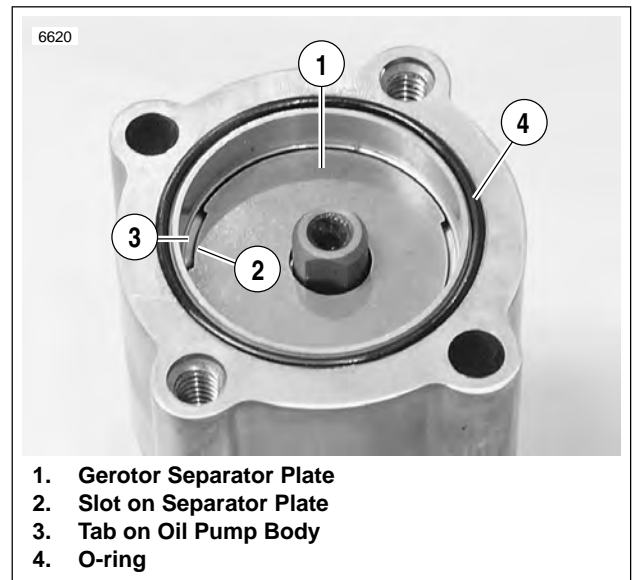

Figure 3-93. Separator Plate Slots

GENERAL

See Figure 3-94. Oil is pressure-fed from the oil pump to the filter mount via rigid external steel line. Oil travels through the filter mount into the filter through the outer filter holes.

Adequate oil pressure activates the oil pressure indicator switch in the filter mount, which turns off the oil pressure indicator lamp.

The check ball in the filter adapter “opens” at 4-6 psi (28-41 kPa) oil pressure. Filtered oil leaves the filter, flowing past the check ball.

DISASSEMBLY

1. Drain oil reservoir and remove filter. See 1.5 ENGINE LUBRICATION SYSTEM.
2. See Figure 3-94. Remove filter adapter from filter mount. Remove check ball and spring.
3. Detach indicator lamp wire from oil pressure indicator switch. Remove switch using OIL PRESSURE SENDING UNIT WRENCH (Part No. HD-41675).

CLEANING AND INSPECTION

Thoroughly clean all parts in cleaning solvent. Blow out holes and passages using compressed air.

ASSEMBLY

NOTE

Use *TEFLON PIPE SEALANT* or *HYLOMAR* on all fittings installed to oil filter mount.

1. See Figure 3-94. Install oil pressure indicator switch using OIL PRESSURE SENDING UNIT WRENCH (Part No. HD-41675). Tighten to 4-6 ft-lbs (5-8 Nm).
2. Attach indicator lamp wire.

NOTE

The filter adapter has identical ends; either end may be installed into the filter mount.

3. Apply several drops of **LOCTITE®** thread locker 243 (blue) to last few threads on that end of the filter adapter which is installed into filter mount. Do not apply **LOCTITE** to adapter threads on filter element side.
4. Install filter mount components.
 - a. Place spring and check ball into threaded hole at center of mount.
 - b. Push threaded end of filter adapter (with **LOCTITE**) against check ball to compress spring.
 - c. Screw adapter into threaded hole. Tighten to 8-12 ft-lbs (10.8-16.3 Nm).
5. Install a **new** filter and fill oil reservoir with proper oil. See 1.5 ENGINE LUBRICATION SYSTEM.

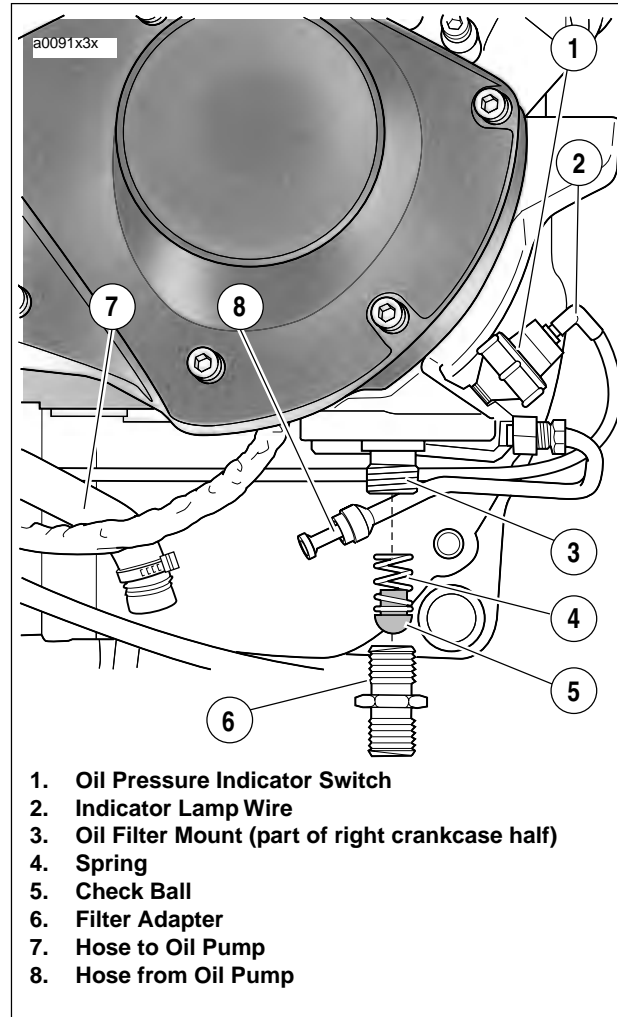

Figure 3-94. Oil Filter Mount Assembly

GENERAL

See Figure 3-95. The lifter assembly consists of a hydraulic lifter and roller. The lifter and roller, under compression force from valve spring, follow the surface of the revolving cam. The up-and-down motion produced is transmitted to the valve by the push rod and rocker arm. The lifter contains a piston (or plunger) and cylinder; it also contains a check valve, which allows the unit to fill with engine oil, thereby reducing clearance in the valve train.

When a lifter is functioning properly, the assembly operates with minimal lifter clearance. The unit automatically compensates for heat expansion to maintain a no-clearance condition.

It is normal for lifters to click when engine is started after standing for some time. Hydraulic lifters have a definite leak-down rate which permits the oil in the lifters to escape. This is necessary to allow units to compensate for various expansion conditions of parts and still maintain correct clearance operation. Lifters are functioning properly if they become quiet after a few minutes of engine operation.

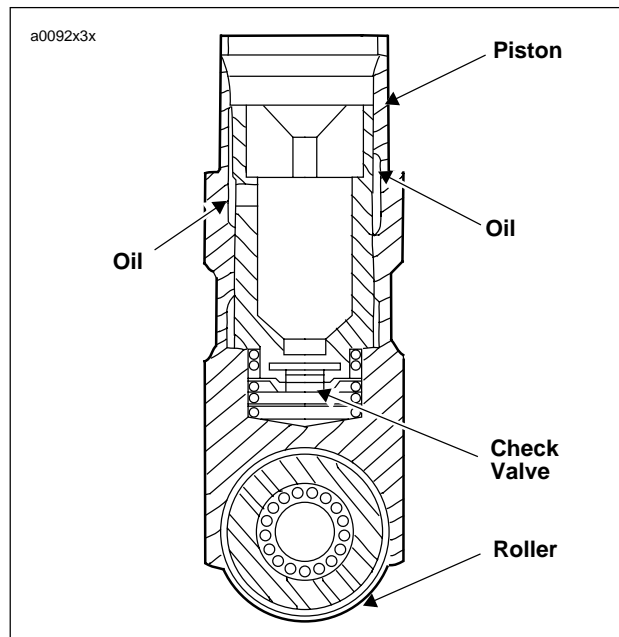

Figure 3-95. Lifter Assembly (Typical)

REMOVAL

1. Clean all dirt from around crankcase. Blow loose particles from area with compressed air.
 2. Remove the lower rocker cover. Pull each push rod upward through top of cylinder head. See 3.5 CYLINDER HEAD.
 3. Remove cylinder head assembly. See 3.5 CYLINDER HEAD.
 4. See Figure 3-96. Remove push rod cover.
 - a. Remove screws.
 - b. Remove push rod cover.
 - c. Remove gasket and o-rings. Discard parts.
 5. Remove both valve hydraulic lifters.
 - a. Remove anti-rotation screws.
 - b. Remove lifters from crankcase bore using a thin-bladed screwdriver. Mark the location and orientation (front/back) of each lifter.
- b. Fit a **new** lifter and/or replace crankcases if clearance exceeds SERVICE WEAR LIMIT of 0.0030 in. (0.076 mm).
3. Check lifter roller freeplay.
 - a. Roller clearance on pin should be within 0.0006-0.0010 in. (0.0152-0.0254 mm).
 - b. Replace lifters if clearance exceeds SERVICE WEAR LIMIT of 0.0015 in. (0.0381 mm).
 4. Check lifter roller end clearance.
 - a. End clearance should be within 0.008-0.022 in. (0.203-0.559 mm).
 - b. Replace lifters if clearance exceeds SERVICE WEAR LIMIT of 0.026 in. (0.660 mm).
 5. Soak lifters in clean engine oil. Keep covered until assembly.

CLEANING AND INSPECTION

1. Clean all parts, except roller/lifter assembly, thoroughly in solvent. Blow dry with compressed air.

NOTE

Inside and outside micrometers used for measuring tappets and tappet guides must be calibrated to ensure accurate readings.

2. Inspect valve lifters for excessive clearance in guide. Accurately measure lifter bore inner diameter with a gauge.
 - a. Clearance should be within 0.0008-0.0020 in. (0.0203-0.0508 mm).

INSTALLATION

1. See [Figure 3-97](#). Rotate engine so that both lifters, from the cylinder will be installed on the base circle of the cam.
2. Apply a liberal amount of engine oil to each lifter assembly (especially the roller needles) for smooth initial operation.
3. See [Figure 3-96](#). Insert lifter into bore in crankcase. Rotate lifter so that flats at upper end of lifter face the front and rear of the engine. If the lifter is installed incorrectly, anti-rotation screws cannot be inserted.
4. Secure lifters in place.
 - a. Install anti-rotation screws with washers in the holes in lifter block.
 - b. Tighten anti-rotation screws to 80-110 **in-lbs** (9.0-12.4 Nm).
5. Install push rod cover.
 - a. Slide **new** gasket cover over bottom of push rod cover.
 - b. Position push rod cover onto crankcase.
 - c. Install screws through holes in push rod cover into tapped holes in crankcase. Tighten screws evenly to 30-40 **in-lbs** (3.4-4.5 Nm).
 - d. Place **new** o-rings on top of push rod cover.
6. Install push rods, cylinder head, lower and upper rocker covers. See [3.5 CYLINDER HEAD](#).

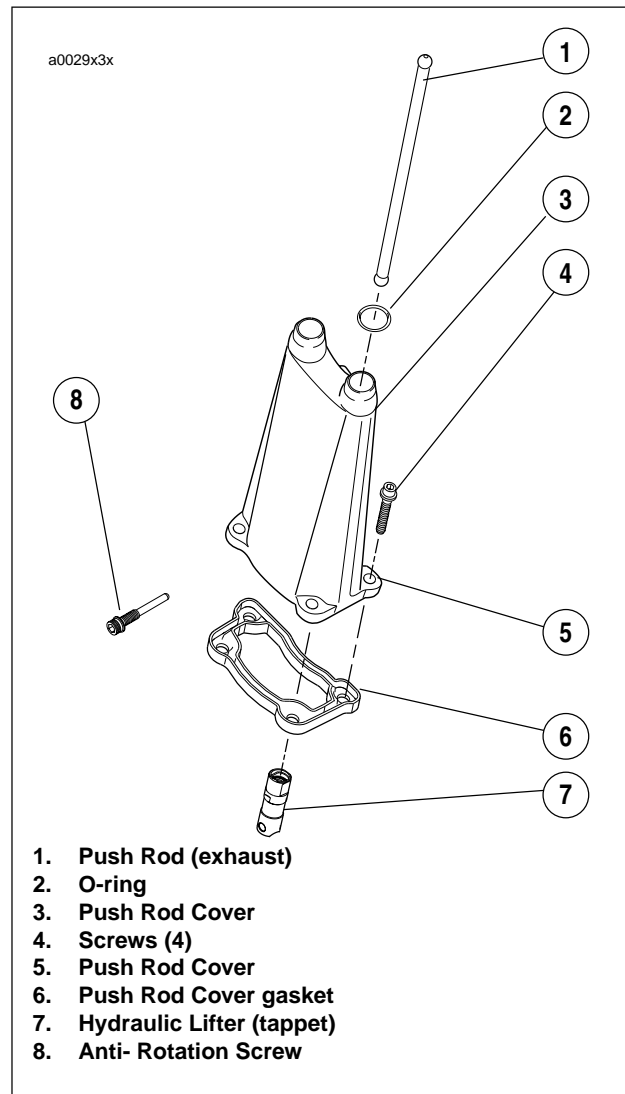

Figure 3-96. Valve Lifter Service

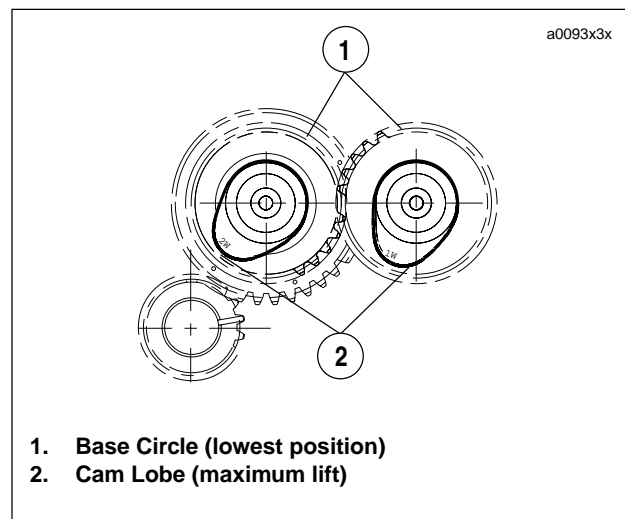

Figure 3-97. Base Circle

GENERAL

Read the complete gearcase section carefully before you begin any service work.

For the gearcase components to operate at their optimum, all components must be properly fitted and matched. Changing one component can affect many others. It is important to know and understand all inspection procedures and how components interact.

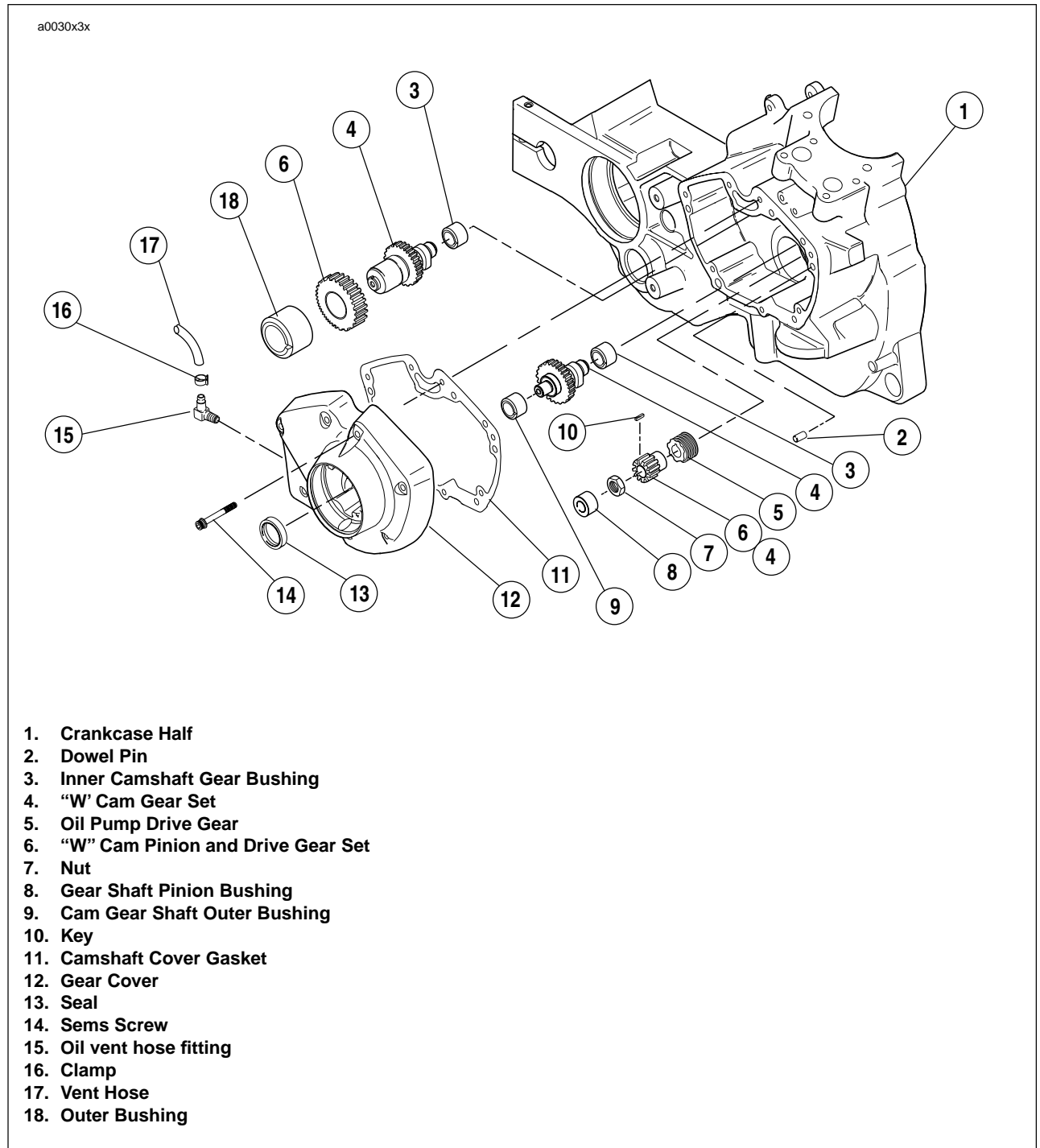

Figure 3-98. Gearcase Cover & Cam Assembly

REMOVAL/DISASSEMBLY

1. See [Figure 3-98](#). Thoroughly clean area around gearcase cover and tappets. Blow loose dirt from crankcase with compressed air.
2. Remove any parts that will interfere with gearcase disassembly.
3. See [3.5 CYLINDER HEAD](#). Remove push rods.
4. See [3.15 HYDRAULIC LIFTERS](#). Remove hydraulic lifters.
5. Check for minimum cam gear end play. Record readings.
6. See [7.8 IGNITION MODULE/ CAM POSITION SENSOR](#). Remove cam position sensor and rotor from gearcase cover.
7. Place a pan under gearcase to collect oil. Remove cover screws. Carefully remove gearcase cover. Discard old gasket.

NOTE

If cover does not come loose on removal of screws, tap lightly with a plastic hammer. Never pry cover off.

8. Remove cam gears.

NOTE

Nut is secured by **LOCTITE®** thread locker 262 (red) on the nut threads.

9. Remove nut. Slide pinion gear and oil pump drive gear off pinion shaft.

CLEANING AND INSPECTION

1. Thoroughly clean gearcase compartment, gearcase cover and gears in solvent to remove oil and carbon deposits.
2. Blow out all cover oil passages and bushings with compressed air.
3. Clean old gasket material from gearcase and cover faces with cleaning solvent.

Cam and Pinion Gear Identification, Inspection, and Selection

See [Figure 3-99](#). Cam lobes are stamped with a number (1 or 2) followed by a letter ("W"). The number (1 or 2) identifies the cam location/function and the letter ("W") indicates model year application:

- 2W=Intake
- 1W = Exhaust

See [Figure 3-100](#). Measure the gear diameter with a micrometer over 0.108 in. (2.743 mm) diameter gauge pins on opposite sides of the gear. The pins are of the proper size to fit between the contacting surfaces of the gear teeth. Gear diameter should be measured in at least two places 90° apart. Use **GAUGE PIN SET** (Part No. HD-38361) when measuring pinion and cam gear sizes.

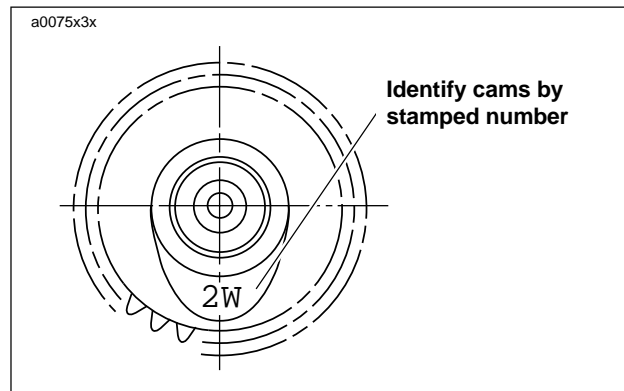

Figure 3-99. Cam Identification

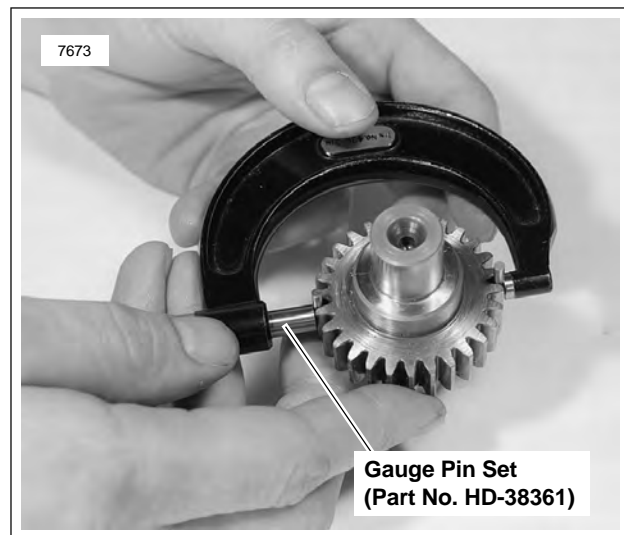

Figure 3-100. Measuring Gear Size

Cam gears are individually selected for each specific gear cover through sophisticated computer-aided measuring techniques in a controlled environment. Each gear is assigned an individual color code based on its diameter (measured with gauge pins). When cam gears are replaced, always use the same color code as found on gears being replaced to ensure that the gear operation remains as quiet as possible. For location of cam gear color codes, see [Figure 3-101](#). Pinion gear and large gear on intake cam are one size only. No selective sizing is possible. If damaged, replace both gears as a pair.

NOTE

On flywheel pinion shaft, a paint dot is located on the shaft perimeter near the centerline of the keyway. This dot identifies the pinion shaft inner race size. Do not use this dot to select pinion gear size.

See [Table 3-12](#). Compare the previously measured diameter of each gear with the specifications (listed in inches) shown in the table to determine amount of wear on gear teeth.

NOTE

Prior to changing any cam gears, check gear shaft fit within corresponding bushings. Worn bushings can cause excessive backlash.

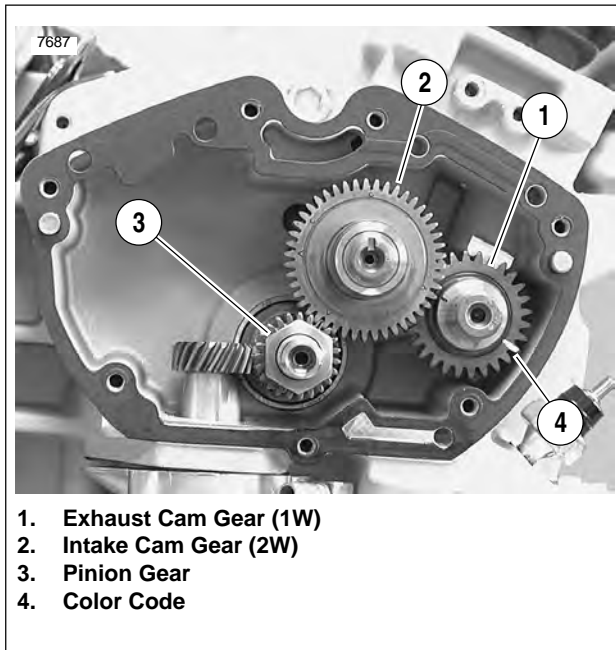

Figure 3-101. Cam and Pinion Gear Color Code Location and Timing Mark Indexing

Table 3-12. Cam and Pinion Gear Color Code and Diameter

GEAR NO. & POSITION	2 INBOARD	2 OUTBOARD	1	3
COLOR CODE (1 paint dot)	Intake	Intake	Exhaust	Pinion
RED	1.9025-1.9029 (48.323-48.333)		1.9025-1.9029 (48.323-48.333)	
WHITE	1.9020-1.9024 (48.310-48.321)		1.9020-1.9024 (48.310-48.321)	
GREEN	1.9015-1.9019 (48.298-48.308)		1.9015-1.9019 (48.298-48.308)	

Bushing Inspection and Removal

- See [Figure 3-98](#). Bushings are press fit in gearcase cover and crankcase. Inspect each bushing against its corresponding cam gear shaft or pinion gear shaft. See [Table 3-13](#).

Table 3-13. Gear Shaft Specifications

GEAR SHAFT	CORRECT CLEARANCE	SERVICE WEAR LIMIT
Cam	0.0007-0.0022 in. (0.0178-0.0559 mm)	0.003 in. (0.076 mm)
Pinion	0.0023-0.0043 in. (0.0584-0.1092 mm)	0.0050 in. (0.1270 mm)

- See [Figure 3-102](#). Use a BUSHING AND BEARING PULLER (Part No. HD-95760-69A) to remove bushings from gearcase cover and crankcase.

Bushing Installation

NOTE

Installing and reaming crankcase and gearcase cover bushings may alter the center distances between mating gears and may result in an increase in gear noise. For quiet-running gears, the gears should be matched to the center distances.

CAM GEAR BUSHINGS IN RIGHT CRANKCASE HALF

- See [Figure 3-103](#). Each cam gear bushing, to be installed in right crankcase half, must be positioned in crankcase bore with its oiling slot at crankcase slot.
- Using an arbor press, UNIVERSAL DRIVER HANDLE (Part No. HD-33416), and CAMSHAFT NEEDLE BEARING (Part No. HD-97273-60) install each bushing in its crankcase bore so that bushing shoulder contacts crankcase boss.
- See [Bushing Reaming](#). After you install a **new** bushing in right crankcase half, ream the bushing to correct size.

CAM GEAR BUSHINGS (EXCEPT INTAKE BUSHING) IN GEARCASE COVER

- See [Figure 3-104](#). Using an arbor press, install each bushing in its gearcase cover bore so that bushing shoulder contacts cover boss. Position each bushing so the oiling slot is at the 3 o'clock position within the gearcase cover bore.
- See [Bushing Reaming](#). After you install a **new** bushing in gearcase cover, line-ream the bushing to correct size.

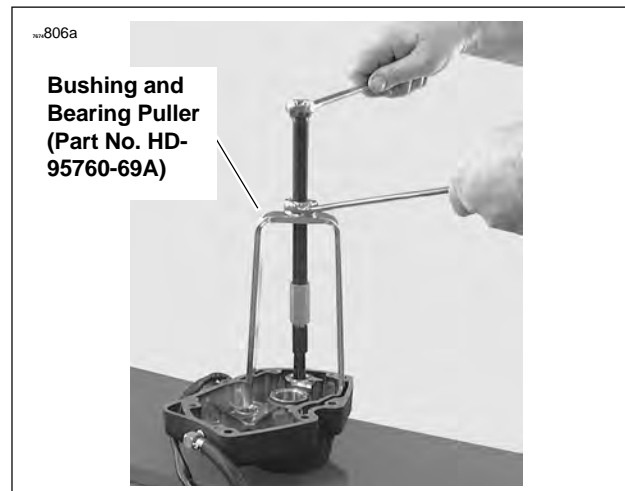

Figure 3-102. Removing Bushing

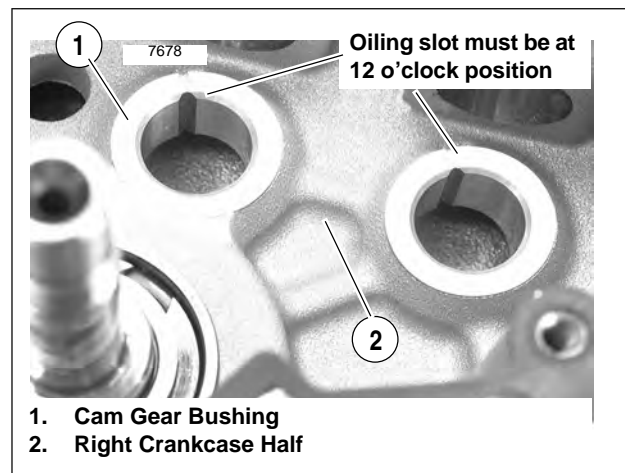

Figure 3-103. Cam Gear Bushing Installed in Crankcase

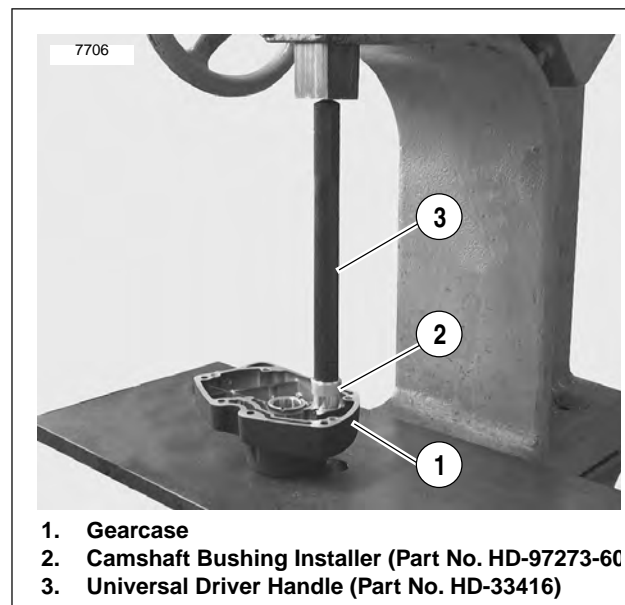

Figure 3-104. Arbor Press

INTAKE CAM GEAR BUSHING IN GEARCASE COVER.

See [Figure 3-98](#). The intake cam gear bushing must be installed in its gearcase cover bore using an arbor press. You will need to orient the bushing in a specific position of rotation within the cover bore according to the following procedures:

1. See [Figure 3-105](#). Position bushing over bore of gearcase cover with chamfered edge downward and slot upward. Align slot in bushing with slot in gearcase cover boss. Press bushing into cover bore until bushing is flush with cover boss.
2. See [Bushing Reaming](#). After you install a **new** bushing in gearcase cover, line-ream the bushing to the correct size.

PINION SHAFT BUSHING IN GEARCASE COVER

1. See [Figure 3-98](#). Using an arbor press, install pinion shaft bushing in its gearcase cover so that bushing is flush with cover boss. There is no need to orient this particular bushing in any specific position of rotation within the gearcase cover bore.
2. Although the original pinion shaft bushing is not “pinned,” the replacement bushing must be secured, from possible rotation within the cover bore, by installation of a dowel pin. See [Figure 3-106](#). Drill a No. 31 hole, 0.281 in. (7.137 mm) deep, at top side of boss (side toward top of gearcase cover), centering the drill bit on the cover bore circle (hole is drilled half in bushing OD and half in cover bore ID).
3. Drive a **new** dowel pin no more than 0.20 in. (5.08 mm) below the bushing face. Carefully peen edges of hole to lock the pin in place.
4. See [Bushing Reaming](#). After you install a **new** bushing in gearcase cover, line-ream the bushing to the correct size.

Bushing Reaming

NOTE

- *Installing and reaming crankcase and gearcase cover bushings may alter the center distances between mating gears and may result in an increase in gear noise. For quiet-running gears, the gears should be matched to the center distances.*
- *Bushings in right crankcase half serve as pilots for reaming gearcase cover bushings and must, therefore, be reamed to size first.*
- *After reaming any bushing, check shaft fit in the bushing. It may be necessary to make a second pass with reamer to attain proper fit.*

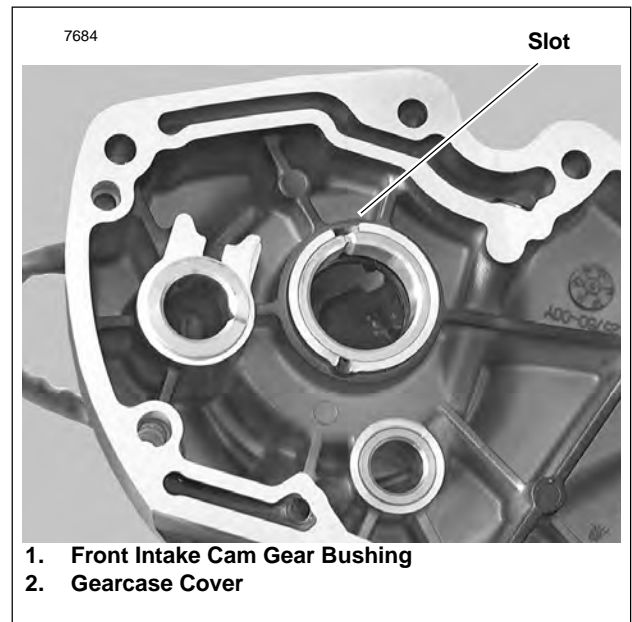

Figure 3-105. Rear Intake Cam Gear Bushing Installed in Gearcase Cover

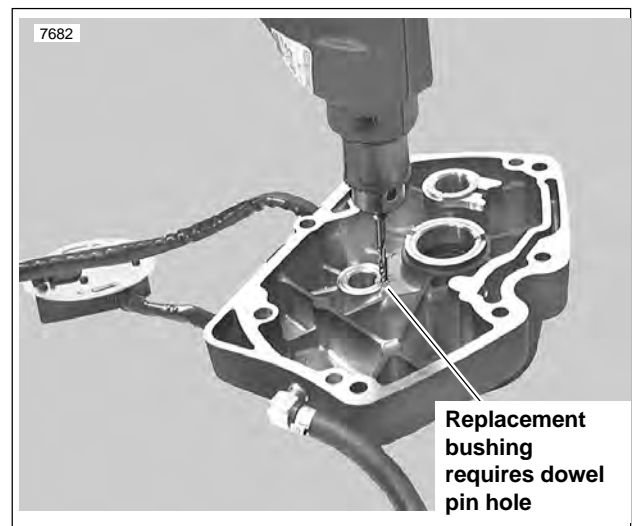

Figure 3-106. Drilling Dowel Pin Hole

CAM GEAR BUSHINGS IN RIGHT CRANKCASE HALF

1. Separate two halves of crankcase, if not already accomplished. Place right crankcase half on flat surface with gearcase side upward. Bushing to be reamed must be oriented as shown in [Figure 3-103](#).
2. See [Figure 3-107](#). Position CAMSHAFT BUSHING REAMER PILOT (Part No. B-43988) onto gearcase side of crankcase half; upper right and lower left indexing holes in pilot must be placed over dowels in crankcase half. Insert two bolts (supplied with pilot) through two remaining holes in pilot, and into threaded holes of crankcase half. Tighten bolts securely.
3. Insert REAMER (Part No. HD-38871-2) through pilot hole and into bushing while turning reamer clockwise. Continue turning reamer clockwise through bushing until smooth shank of reamer passes through hole in pilot.
4. Detach reamer from handle. Pull reamer out opposite side of crankcase half.
5. Thoroughly clean right crankcase half, removing all metal chips/shavings. Blow out all oil passages using compressed air.

EXHAUST GEAR BUSHING IN GEARCASE COVER

NOTE

Newly installed cam gear bushings in the gearcase cover must be line reamed, using the right crankcase half as a pilot for the reamer, to establish correct clearance and to ensure perfect alignment. If crankcase halves are not separated on your motorcycle, use a spare right crankcase half to perform the following line reaming procedures.

1. See [Figure 3-98](#). Bushings to be reamed must be installed in gearcase cover as described in [BUSHING INSTALLATION](#). Attach gearcase cover to right crankcase half, which has been disassembled from left crankcase half, securing with a minimum of three mounting screws.
2. Insert REAMER (Part No. HD-38871-2) through the previously reamed cam gear bushing in right crankcase half, which is in line with exhaust bushing to be reamed in gearcase cover.
3. Turn reamer clockwise through bushing in cover until reamer bottoms. Then give reamer one complete clockwise turn to size the bushing. Continue turning reamer clockwise while extracting reamer from bushing.
4. Separate gearcase cover from right crankcase half. Inspect bushings for proper cam gear shaft fit. Repeat line reaming operation if necessary.

Safety glasses or goggles must be worn while removing metal chips/shavings. Failure to wear safety glasses or goggles could result in death or serious injury.

5. Thoroughly clean gearcase cover, removing all metal chips/shavings. Blow out all oil passages using compressed air.

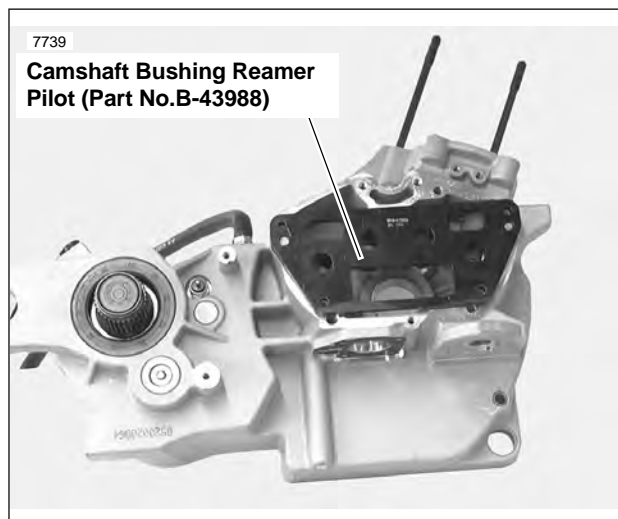

Figure 3-107. Reaming Cam Gear Bushing in Right Crankcase Half

INTAKE CAM GEAR BUSHING IN GEARCASE COVER

NOTE

A newly installed intake cam gear bushing in the gearcase cover must be line reamed, using the right crankcase half as a pilot for the reamer, to establish correct clearance and to ensure perfect alignment. If crankcase halves are not separated on your motorcycle, use a spare right crankcase half to perform the following line reaming procedures.

1. See [Figure 3-98](#). Intake cam gear bushing must be installed in gearcase cover as described in [BUSHING INSTALLATION](#).
2. Identify the previously reamed intake cam gear bushing in right crankcase half, which has been disassembled from left crankcase half. Insert the shank end of REAR INTAKE CAMSHAFT BUSHING REAMER (Part No. HD-94804-67) through gearcase side of this bushing.
3. With reamer inserted into bushing in right crankcase half, attach gearcase cover to right crankcase half, securing with a minimum of three mounting screws.
4. Turn reamer clockwise through bushing in gearcase cover until reamer bottoms. Then give reamer one complete clockwise turn to size the bushing. Continue turning reamer clockwise while extracting reamer from bushing.
5. Separate gearcase cover from right crankcase half. Inspect bushing for proper cam gear shaft fit. Repeat line reaming operation if necessary.

Safety glasses or goggles must be worn while removing metal chips/shavings. Failure to wear safety glasses or goggles could result in death or serious injury.

6. Thoroughly clean gearcase cover, removing all metal chips/shavings. Blow out all oil passages using compressed air.

PINION SHAFT BUSHING IN GEARCASE COVER

NOTE

A **newly** installed pinion shaft bushing in the gearcase cover must be line reamed, using both the right crankcase half and Part No. HD-94812-87 as pilots for the reamer, to establish correct clearance and to ensure proper alignment. If crankcase halves are not separated on your motorcycle, use a spare right crankcase half to perform the following line reaming procedures.

1. See Figure 3-98. Pinion shaft bushing must be installed in gearcase cover as described in BUSHING INSTALLATION. Attach gearcase cover to right crankcase half, which has been disassembled from left crankcase half, securing with a minimum of three mounting screws.
2. See Figure 3-108. Install PINION SHAFT BUSHING REAMER PILOT (Part No. HD-94812-87) into right crankcase roller bearing. Insert PINION SHAFT BUSHING REAMER (Part No. HD-94812-1) through the pilot.
3. Turn reamer clockwise through bushing in gearcase cover until reamer bottoms. Then give reamer one complete clockwise turn to size the bushing. Continue turning reamer clockwise while extracting reamer from bushing.
4. See Figure 3-109. Separate gearcase cover from right crankcase half. Inspect bushing for proper pinion shaft fit. Repeat line reaming operation if necessary.

Safety glasses or goggles must be worn while removing metal chips/shavings. Failure to wear safety glasses or goggles could result in death or serious injury.

5. Remove pilot from right crankcase roller race. Thoroughly clean gearcase cover, removing all metal chips/shavings. Blow out all oil passages using compressed air.

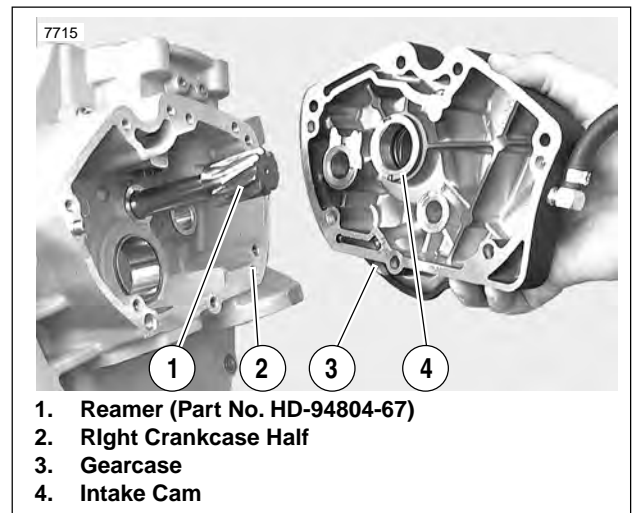

Figure 3-108. Line Reaming Intake Camshaft Bushing

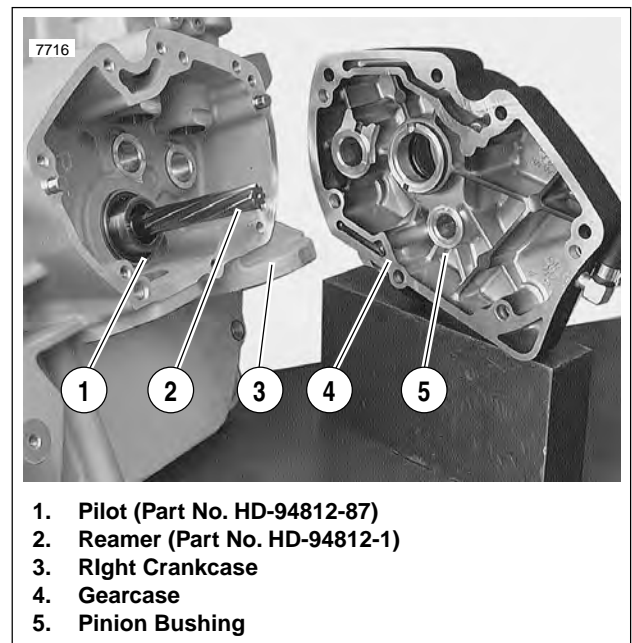

Figure 3-109. Line Reaming Pinion Shaft Bushing

ASSEMBLY/INSTALLATION

1. See [Figure 3-110](#). Install oil pump drive gear and pinion gear on pinion shaft.
 - a. Install shaft key into pinion shaft slot.
 - b. Slide oil pump gear drive gear over pinion shaft. Drive gear must align with shaft key.
 - c. Align keyway in ID of pinion gear with shaft key.
 - d. Slide pinion gear over shaft key and against oil pump drive gear.
2. See [Figure 3-98](#). Install nut.
 - a. Clean threads on pinion shaft and nut.
 - b. See [Figure 3-111](#). Install CRANKSHAFT LOCKING TOOL (Part No. HD-43984) to gearcase with "Side B" facing out, over pinion shaft, with two screws.
 - c. Apply several drops of LOCTITE® thread locker 262 (red) to last few threads of nut.
 - d. Install nut to pinion shaft. Tighten nut to 19-21 ft-lbs (26-28.5 Nm) plus an additional 15° to 17° rotation.
3. See [Figure 3-101](#). Liberally apply engine oil to bushings, shafts, and gears. Install all cam gears into bushings of right crankcase half, properly aligning timing marks of cam gears and pinion gear.

NOTE

Because of the larger diameter additional gear (which meshes with the pinion gear) on the outboard end of the cam, the exhaust cam gear must be installed before the intake cam gear is installed.

4. See [Figure 3-98](#). Install a **new** seal and **new** dry gear-cover gasket on crankcase.

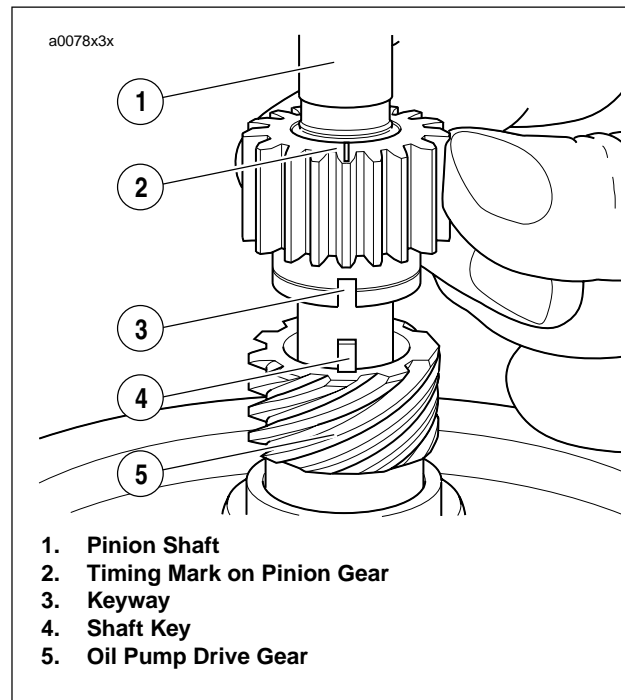

Figure 3-110. Aligning Pinion Gear

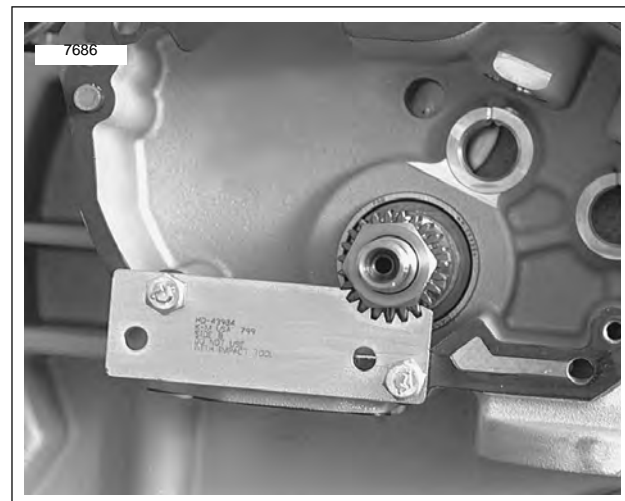

Figure 3-111. Crankshaft Locking Tool (HD-43984)

5. See [Figure 3-112](#). Install gearcase cover over all gears and onto right crankcase half. Secure cover to crankcase half with 7 socket head screws. Tighten screws evenly to 80-110 **in-lbs** (9.0-12.4 Nm). Use torque sequence as shown in [Figure 3-112](#).
6. See [Figure 3-113](#). Check cam gear end play for each cam gear as follows:
 - a. Turn engine over until lobe of cam gear being checked is pointing toward its respective tappet guide hole.
 - b. Gently pry the cam gear toward the gearcase cover using a flat blade screwdriver.
 - c. Measure gap between bushing (in crankcase half) and cam gear shaft thrust face (shoulder) using a feeler gauge. This is cam gear end play.
 - d. Compare cam gear end play measurements with the **SERVICE WEAR LIMITS**. Make repairs as required if end play does not meet specifications.
7. See [3.15 HYDRAULIC LIFTERS](#). Install hydraulic lifters and push rods.
8. Install cam position sensor and rotor in gearcase cover.
9. Install any components removed to gain access to gearcase (i.e. exhaust system components, air cleaner, etc.).

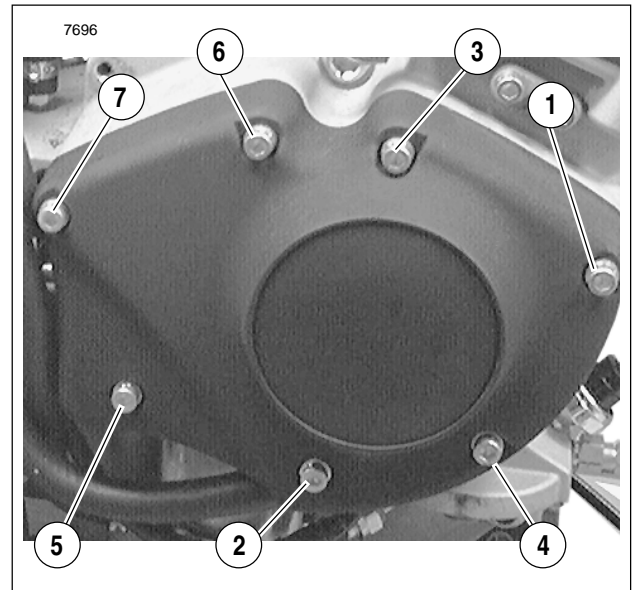

Figure 3-112. Gearcase Cover Mounting Screw Torque Sequence

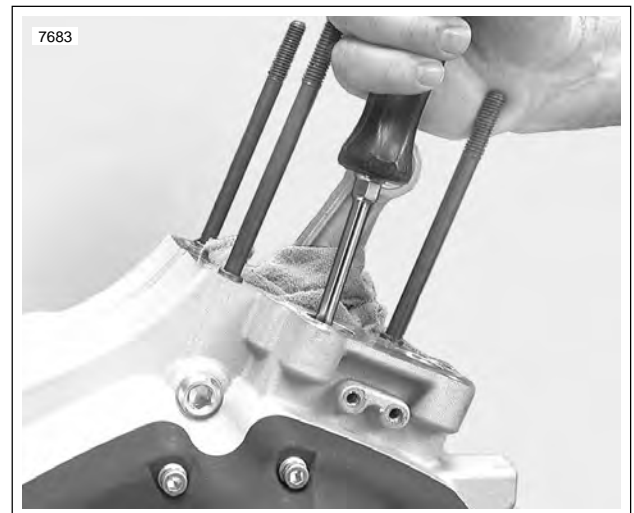

Figure 3-113. Checking Cam Gear End Play

GENERAL

If engine is removed from chassis, do not lay engine on primary side. Placing engine on primary side will damage clutch cable end fitting. If fitting is damaged, clutch cable must be replaced.

See 3.3 STRIPPING MOTORCYCLE FOR ENGINE REPAIR/REMOVAL. Remove engine from chassis to repair pinion shaft bearing or sprocket shaft bearing.

It is recommended procedure to overhaul engine if removed. This includes inspecting and repairing cylinder head, cylinder, gearcase and transmission.

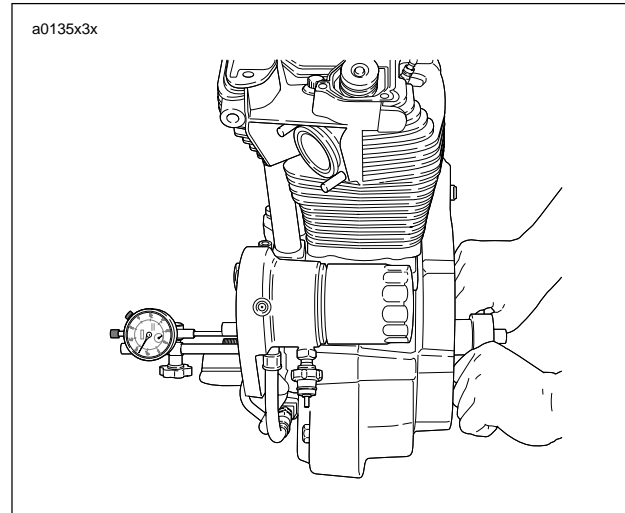

Figure 3-114. Checking Flywheel End Play

ADJUSTMENT/TESTING

Flywheel End Play

Before completely disassembling crankcases, check flywheel end play.

1. After engine has been removed from chassis, securely fasten it to a stand or workbench.
2. See 3.16 GEARCASE COVER AND CAM GEARS. Remove gearcase cover.
3. See Figure 3-114. Attach a dial indicator to gear side crankcase with indicator stem on end of gearshaft.
4. To obtain an accurate flywheel end play reading, preload sprocket shaft bearings. Create a suitable tool by welding two handles to an old engine sprocket nut. Install the nut and sprocket. Tighten to 190-210 ft-lbs (257.6-284.7 Nm).
5. Check flywheel end play.
 - a. Rotate and **push** on sprocket shaft while reading dial indicator.
 - b. Then rotate and **pull** on sprocket shaft while reading dial indicator.
 - c. Replace bearing inner shim if difference (end play) in indicator readings is not 0.001-0.005 in. (0.025-0.127 mm). Choose shim from Table 3-14.

NOTE

Use a thinner shim for less end play; use a thicker shim for more end play.

Table 3-14. Flywheel End Play Shims

PART NUMBER	THICKNESS	
	IN.	MM
9155	0.0975-0.0985	2.4765-2.5019
9142	0.0995 - 0.1005	2.5273-2.5527
9143	0.1015-0.1025	2.5781-2.6035
9144	0.1035 - 0.1045	2.6289-2.6543
9145	0.1055 - 0.1065	2.6797-2.7051
9146	0.1075 - 0.1085	2.7305-2.7559
9147	0.1095 - 0.1105	2.7813-2.8067
9148	0.1115 - 0.1125	2.8321-2.8575
9149	0.1135 - 0.1145	2.8829-2.9083

DISASSEMBLY

Crankcase Halves

1. See 3.5 CYLINDER HEAD. Remove cylinder head.

After removing cylinder, install plastic or rubber hose over cylinder studs. Lifting or moving crankcase by grasping studs will cause cylinder stud damage.

2. See 3.6 CYLINDER AND PISTON. Remove cylinder and piston.

3. See 3.13 OIL PUMP. Remove oil pump.
4. See 3.16 GEARCASE COVER AND CAM GEARS. Remove gearcase components.
5. See 6.2 PRIMARY CHAIN. Remove primary cover and primary drive/clutch components.
6. See 5.7 STARTER. Remove starter motor.
7. See Figure 3-115. Remove screws and rear engine mount bolts securing crankcase halves together.
8. Tap crankcase with plastic mallet to loosen and separate the halves.

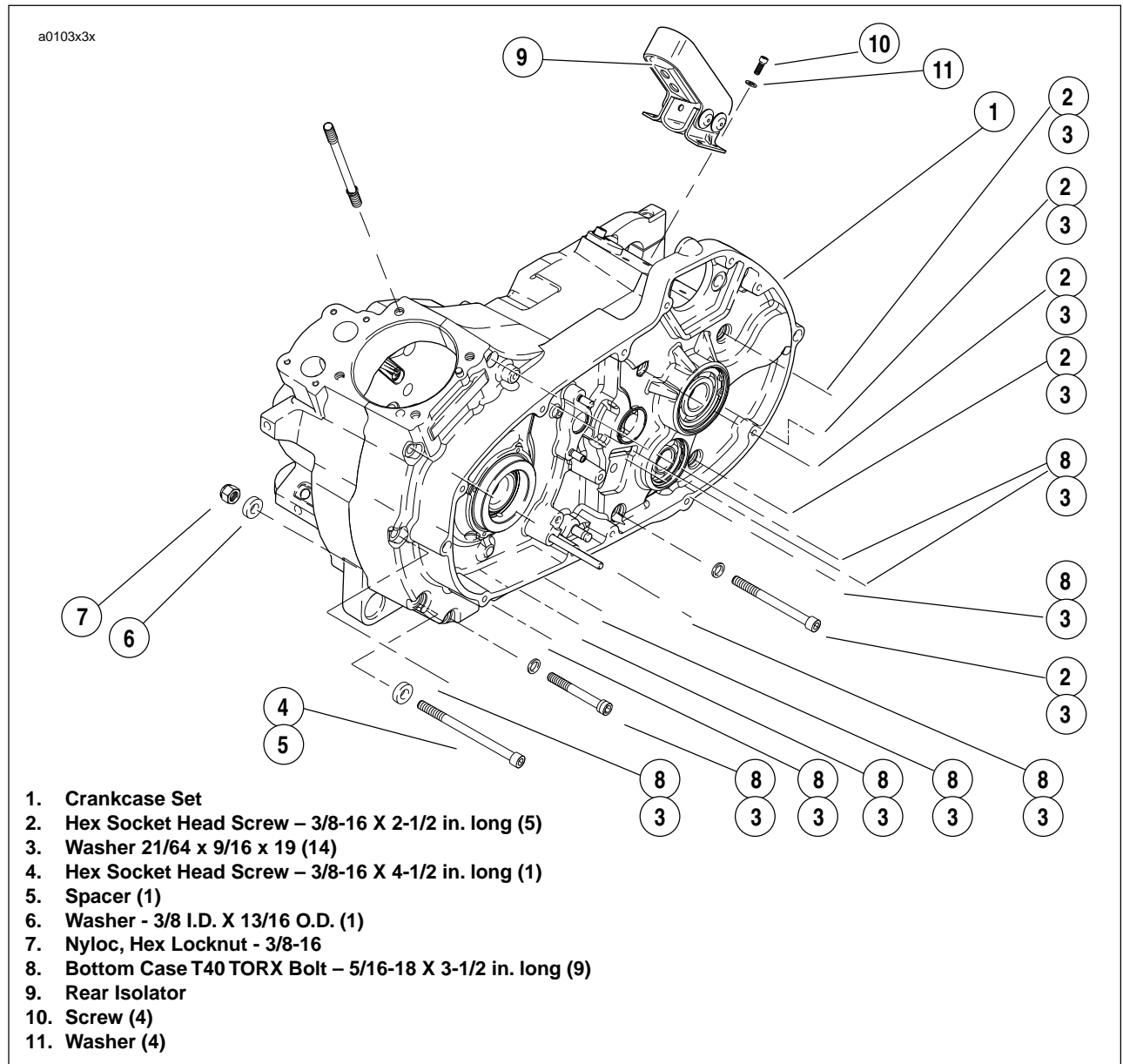

Figure 3-115. Crankcase Hardware

The next step requires using a press. Wear eye protection and make certain set-up is stable. The pressure involved could cause parts to “fly out” with considerable force. Inadequate safety precautions could result in death or serious injury.

9. See Figure 3-116. Mount the left crankcase half and flywheel assembly on a press table, supporting crankcase on parallel bars. Press on end of sprocket shaft with arbor press until flywheel assembly is free from crankcase half. Do not drive flywheel assembly from crankcase half as flywheels may be knocked out of alignment.

NOTE

See Figure 3-117. If it is necessary to remove either the pinion shaft bearing or sprocket shaft bearing, proceed as follows:

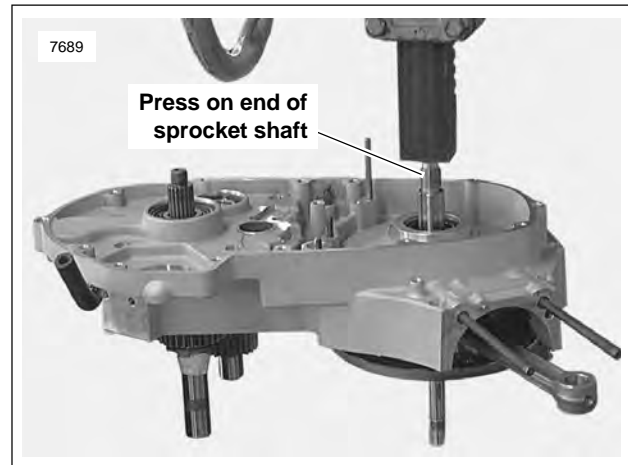

Figure 3-116. Pressing Flywheel from Crankcase

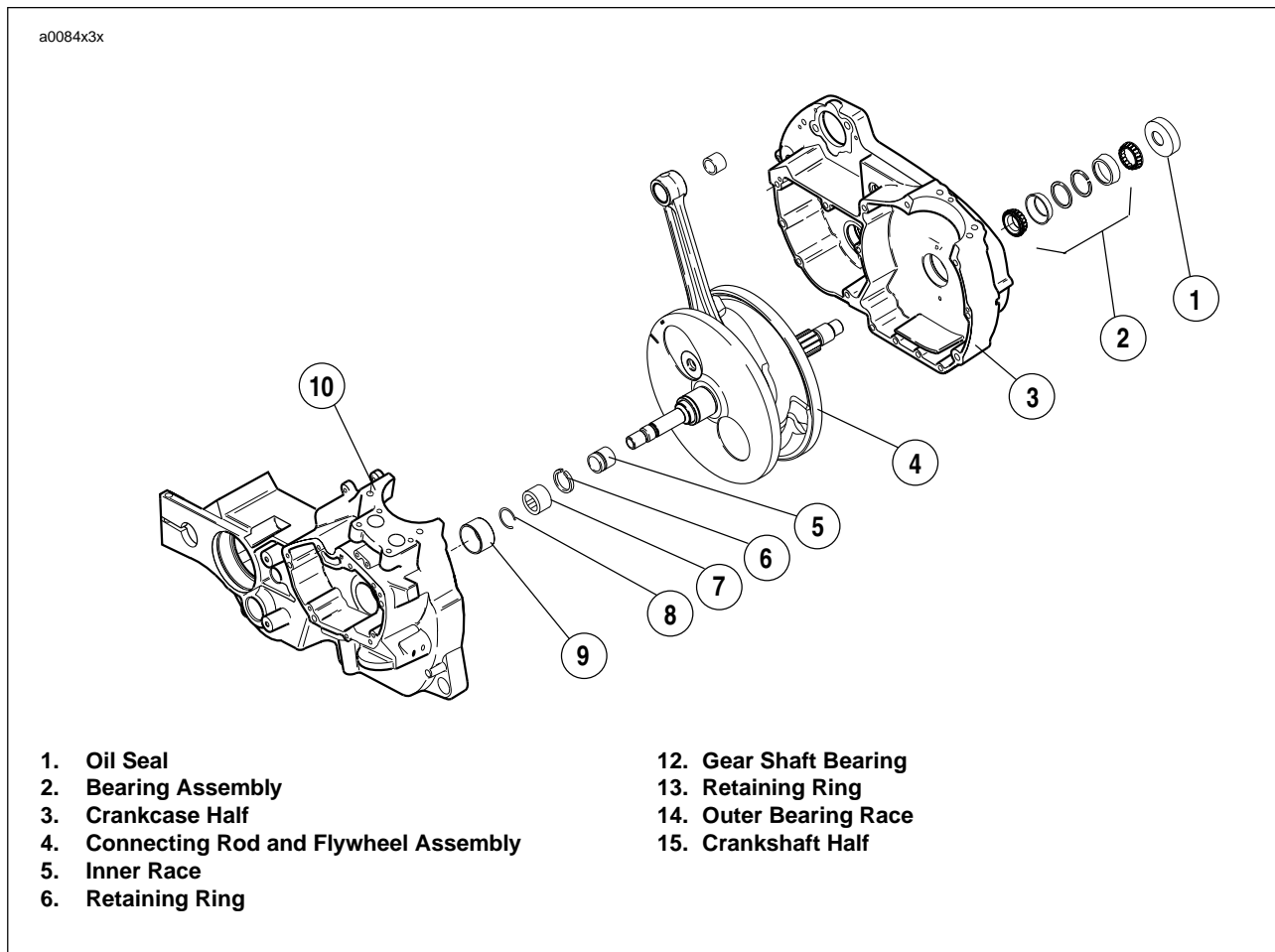

Figure 3-117. Crankcase and Flywheel Assembly

10. Gearshaft bearing will remain on flywheel pinion shaft. Remove retaining ring, and bearing may be slipped off pinion shaft.
11. See [Figure 3-118](#). Place flywheel assembly in FLYWHEEL SUPPORT FIXTURE (Part No. HD-44385). Pull sprocket shaft bearing with SPROCKET SHAFT INNER TIMKIN BEARING REMOVER (Part No. HD-44404) and BEARING RACE REMOVER/INSTALLER (Part No. HD-34902B).
12. See [Figure 3-119](#). Use CRANKSHAFT BEARING TOOL (Part No. HD-94547-101) to remove sprocket shaft outer races.
13. See [Figure 3-120](#). To remove pinion shaft inner race, use WEDGE ATTACHMENT for CLAW PULLER (Part No. HD-95637-46A) with BEARING RACE REMOVER/INSTALLER (Part No. HD-34902B) and END CAP (Part No. HD-34902-7). Apply heat to race to aid removal. Four sizes of pinion bearings are available. Pinion bearing selection at the factory, during engine rebuild, or replacement of crankcase set or flywheel assembly is based on the largest measured outside diameter (OD) of the inner race and the smallest measured inside diameter (ID) of the outer race (crankcase bushing). A running clearance of 0.0002-0.0008 in. (0.0051-0.0203 mm) is established during crankcase set or flywheel assembly replacement and engine rebuild.

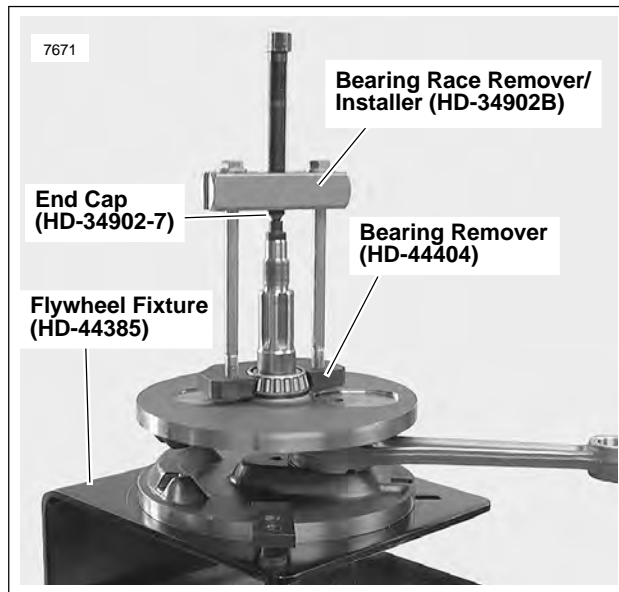

Figure 3-118. Removing Sprocket Shaft Roller Bearing

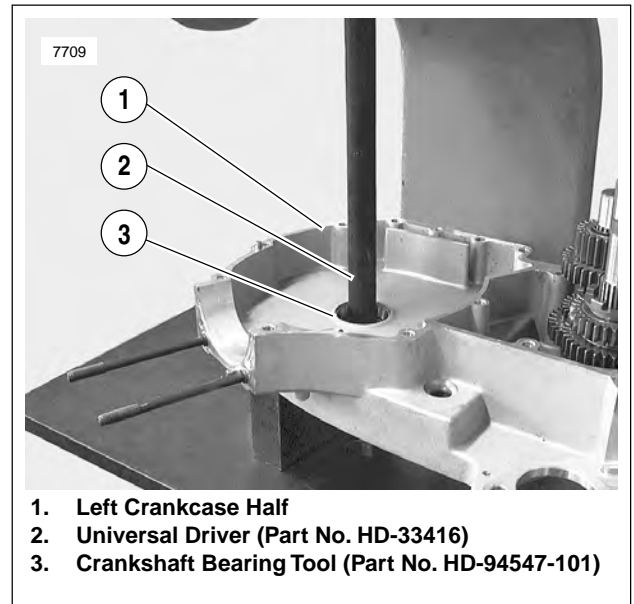

Figure 3-119. Sprocket Outer Shaft Race Removal

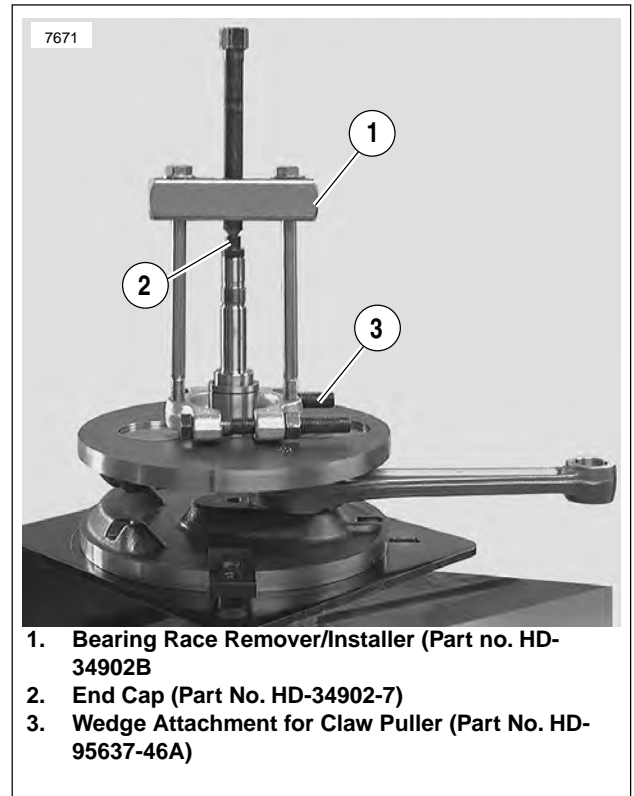

Figure 3-120. Pulling Pinion Shaft Inner Race

14. See Figure 3-121. Installed inner races are identified at the factory as shown.
15. See Figure 3-122. Outer races are identified at the factory as shown.

NOTE

The different sizes of crankcase sets and flywheel assemblies will not have separate part numbers. That is, a replacement crankcase set may have a class 1, 2 or 3 pinion outer race. Replacement flywheel assemblies will have either a class A or B inner race.

16. See Figure 3-123. Pinion bearings are identified as shown.

BEARING SELECTION

See Table 3-15. Pinion Shaft Bearing Selection. Select bearings using the identification information given for inner and outer races and bearings.

NOTE

If either inner or outer race show wear, measure both races to confirm correct bearing fit.

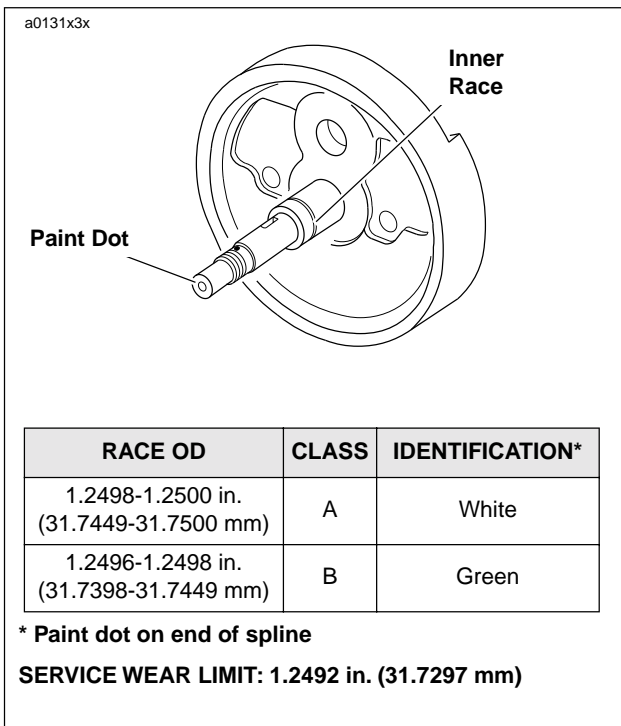

Figure 3-121. Factory Inner Race Sizes

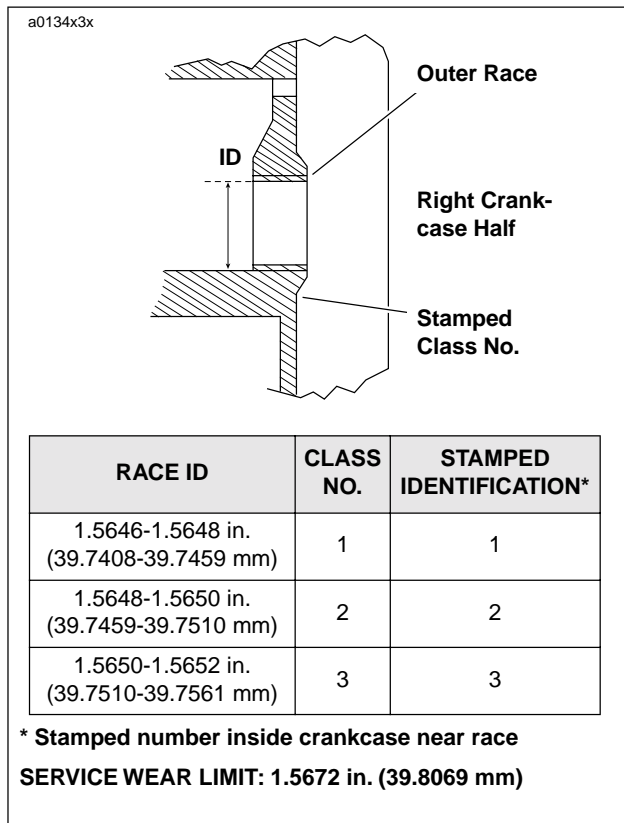

Figure 3-122. Factory Outer Race Sizes

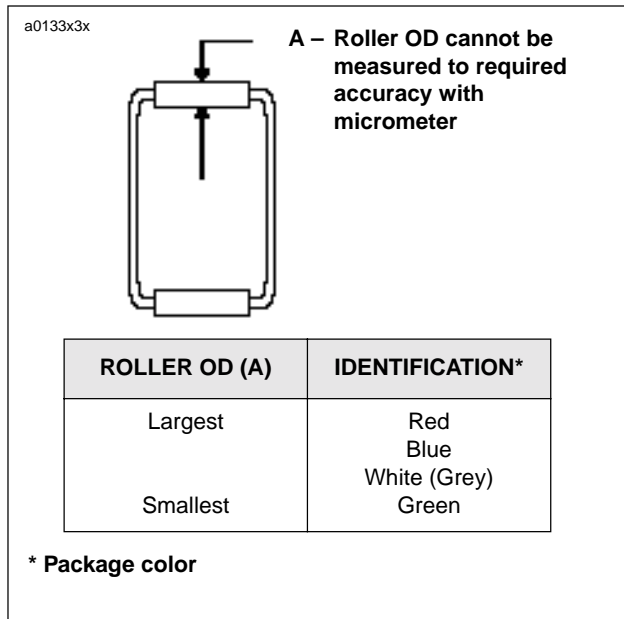

Figure 3-123. Bearing Identification

1. Use a dial bore gauge to measure and record ID of outer race. Take four measurements on ID where bearing rollers ride.
 - a. If the largest measurement is larger than 1.5672 in. (39.8069 mm) or the required lapping to remove wear marks would enlarge bore beyond 1.5672 in., continue at Step 5.
 - b. If largest measurement is 1.5672 in. (39.8069 mm) or less, cover the cam bearings with masking tape to prevent debris from entering bearings. Assemble crankcase halves.

NOTE

The next step requires lapping the outer race. To keep sprocket shaft and pinion shaft bearings aligned the lap must be supported by an adaptor or pilot in the left crankcase half.

2. See **LAPPING ENGINE MAIN BEARING RACES**. Lap race until all wear marks are removed.
3. Measure and record ID of race at four places.
4. Check measurements against these specifications:

Largest ID measured: 1.5672 in. (39.8069 mm) or less

Roundness of ID: within 0.0002 in. (0.0051 mm)

Taper: within 0.0002 in. (0.0051)

 - a. If lapping increased bore ID to larger than 1.5672 in. (39.8069 mm), go to Step 5.
 - b. If roundness or taper do not meet specifications, continue lapping until specifications are met.
 - c. If all specifications are met, continue at Step 7 to remove and size inner race.

5. Press the outer race from the right crankcase. Press **new** outer race into crankcase flush with inside edge of cast-in insert.

See **Figure 3-124**. Dimensions are shown for fabrication of tools used in pressing the outer race into or out of crankcase.

6. See **LAPPING ENGINE MAIN BEARING RACES**. The **new** outer race must be lapped slightly to true and align with left case bearing and to meet the following specifications.

ID: 1.5646 - 1.5652 in. (39.7408 - 39.7561 mm)

Roundness: within 0.0002 in. (0.0051 mm)

Taper: within 0.0002 in. (0.0051 mm)

Surface finish: 16 RMS

7. See **Figure 3-125**. Pull inner race from pinion shaft using **WEDGE ATTACHMENT** for **CLAW PULLER** (Part No. HD-95637-46A) with **BEARING RACE REMOVER/INSTALLER** (Part No. HD-34902B) and **END CAP** (Part No. HD-34902-7). Apply heat to race to aid removal.
8. See **Figure 3-125**. Press **new** inner race on pinion shaft as shown. The **new** inner race must be ground by a competent machinist to OD dimension range for the finished lapped ID of the outer race. See **Table 3-15**. The finished inner race must meet these specifications. For necessary dimensions for constructing a press-on tool see **Figure 3-124**. When the tool bottoms against the flywheel, correct inner race location is automatically established.

Roundness: within 0.0002 in. (0.0051 mm)

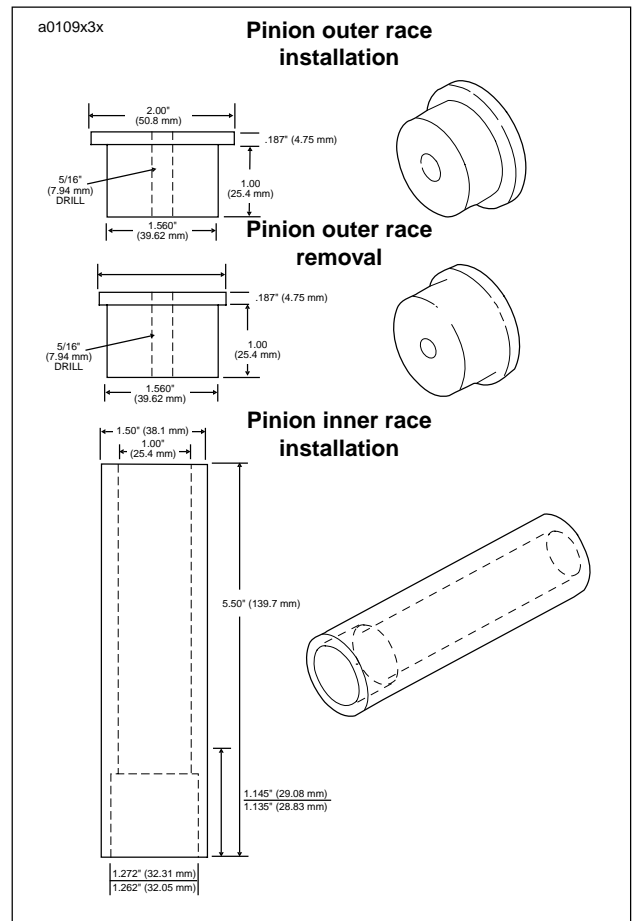

Figure 3-124. Pinion Shaft Bearing Tools

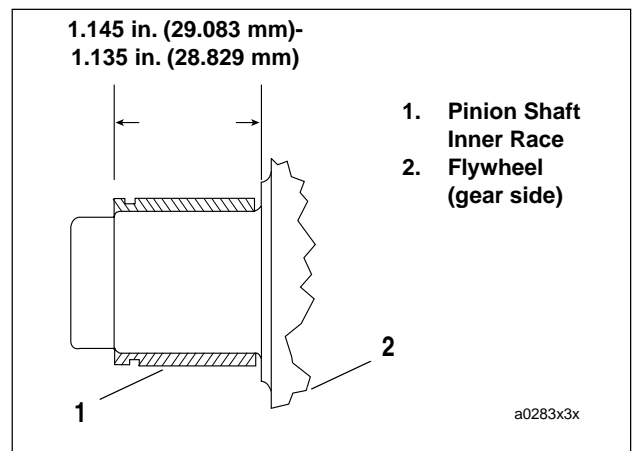

Figure 3-125. Inner Race Location

Taper: within 0.0002 in. (0.0051 mm)

Surface finish: 16 RMS

NOTE

Always use the smallest outer race ID measurement and the largest OD inner race measurement when selecting bearings.

9. The following example illustrates how to determine the required inner race OD.
 - a. See **Table 3-15**. For example purposes, suppose the smallest outer race ID measurement is 1.5651 in. (39.754 mm). This requires an inner race OD range of 1.2496-1.2504 in. (31.740 - 31.760 mm).

NOTE

Have machinist grind outer race to center or middle of required OD range. This will prevent grinding outer race undersize and gives a more easily achieved tolerance range.

- b. Grind inner race. Measure OD at four places. Check that specifications in Step 8 are met.

- c. For example purposes, suppose the largest inner race OD measurement after grinding is 1.2499 in. (31.747 mm) OD.
- d. With a 1.5651 in. (39.754 mm) ID outer race and a 1.2499 in. (31.747 mm) OD inner race, a blue bearing is required.

Table 3-15. Pinion Shaft Bearing Selection

FAC-TORY STAMP ED NUM-BER	OUTER RACE ID	BEARING SIZE AS IDENTIFIED BY COLOR CODING											
	over 1.5672 in. 39.807 mm	Service Wear Limit Exceeded – Replace Outer Race and Resize											
	1.5670-1.5672 in. 39.802-39.807 mm												Red
	1.5668-1.5670 in. 39.797-39.802 mm											Red	Blue
	1.5666-1.5668 in. 39.792-39.797 mm									Red	Blue	White-Gray	
	1.5664-1.5666 in. 39.787-39.792 mm								Red	Blue	White-Gray	Green	
	1.5662-1.5664 in. 39.781-39.787 mm							Red	Blue	White-Gray	Green		
	1.5660-1.5662 in. 39.776-39.781 mm						Red	Blue	White-Gray	Green			
	1.5658-1.5660 in. 39.771-39.776 mm					Red	Blue	White-Gray	Green				
	1.5656-1.5658 in. 39.766-39.771 mm				Red	Blue	White-Gray	Green					
	1.5654-1.5656 in. 39.761-39.766 mm			Red	Blue	White-Gray	Green						
	1.5652-1.5654 in. 39.756-39.761 mm		Red	Blue	White-Gray	Green							
3	1.5650-1.5652 in. 39.751-39.756 mm	Red	Blue	White-Gray	Green								
2	1.5648-1.5650 in. 39.746-39.751 mm	Blue	White-Gray	Green									
1	1.5646-1.5648 in. 39.741-39.746 mm	White-Gray	Green										
INNER RACE OD (In)		1.2496-1.2498 in.	1.2498-1.2500 in.	1.2500 - 1.2502 in.	1.2502 - 1.2504 in.	1.2504 - 1.2506 in.	1.2506 - 1.2508 in.	1.2508 - 1.2510 in.	1.2510 - 1.2512 in.	1.2512 - 1.2514 in.	1.2514 - 1.2516 in.	1.2516 - 1.2518 in.	1.2518 in.
		31.740 31.745 mm	31.745 31.750 mm	31.750 - 31.755 mm	31.755 - 31.760 mm	31.760- 31.765 mm	31.765 - 31.770 mm	31.770 - 31.775 mm	31.775 - 31.780 mm	31.780 - 31.786 mm	31.786 - 31.791 mm	31.791 - 31.796 mm	31.796 mm
FACTORY COLOR CODE		Green	White										

Lapping Engine Main Bearing Races

1. Secure right and left crankcase halves with three crankcase stud bolts (top center and bottom left and right). The sprocket shaft bearing outer races and large spacer must be installed in left crankcase.
2. See [Figure 3-126](#). Obtain CRANKCASE MAIN BEARING LAPPING TOOL (Part No. HD-96710-40B). Assemble CRANKCASE MAIN BEARING LAP (Part No. HD-96718-87) to lapping handle. Assemble guide sleeve to sprocket shaft bearing bushing. Sleeves, for use with tapered bearing, are assembled to case with bearings and small spacer collar. Finger-tighten the sleeve parts.
3. Insert lap shaft with arbor assembled through pinion bearing bushing and into guide sleeve. Tighten arbor expansion collars using a length of 0.156 in. (3.962 mm) rod as spanner until arbor begins to drag. Do not adjust arbor snug in bushing or bushing will “bell,” a condition where hole is larger at ends than it is in the center.
4. Withdraw arbor far enough to coat lightly with 220 grit lapping compound. Do not apply a heavy coat. Reposition lap in bushing and turn handle at moderate hand speed. Work lap back and forth in bushing, as it is revolved, to avoid grooving and tapering.

At frequent intervals, remove lap from crankcase, wash and inspect bushing. Lapping is completed when entire bushing surface has a dull, satin finish rather than a glossy, smooth appearance. If necessary, flush off lap in cleaning solvent, air dry and apply fresh, light coat of fine lapping compound.

Checking Connecting Rod Side Play

1. See [Figure 3-127](#). Check connecting rod side play with a thickness gauge as shown.
2. If side play measurement is greater than service wear limit listed below, replace flywheel/connecting rod assembly.
 - 0.030 in. (0.762 mm)

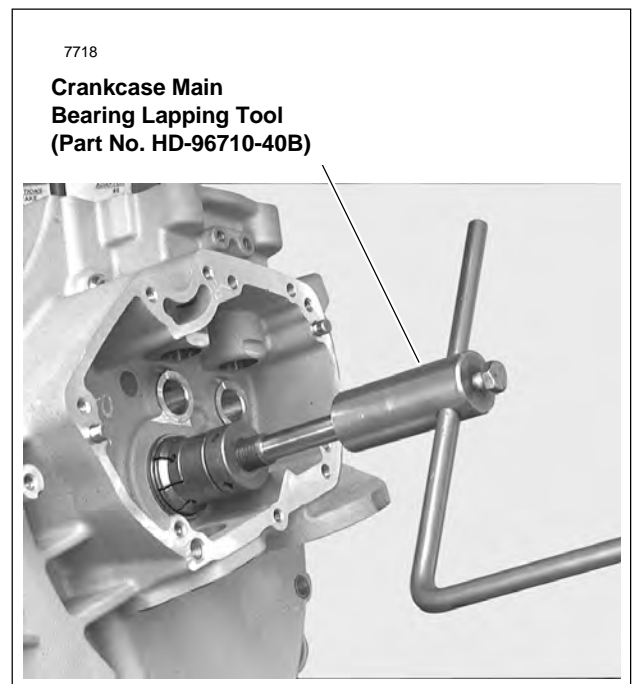

Figure 3-126. Lapping Pinion Shaft Main Bearing

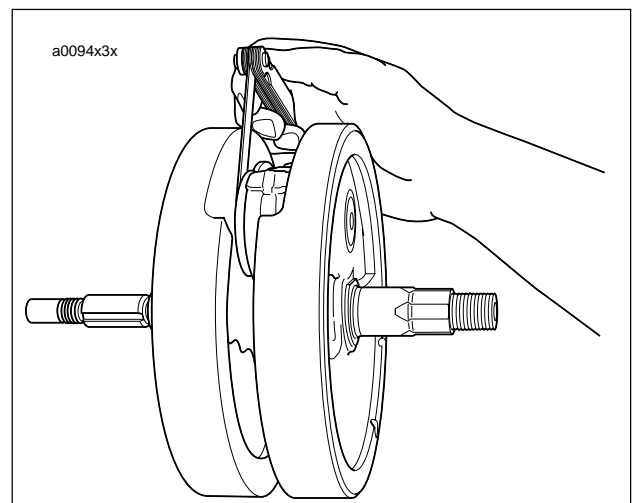

Figure 3-127. Checking Connecting Rod Side Play

ASSEMBLY

Crankcase Halves

Lubricate all parts with Harley-Davidson 20W50 engine oil, and proceed as follows:

1. See [Figure 3-128](#). Install **new** snap ring to crankcase bore (if bearings were replaced).
 - a. Place the crankcase half on a flat surface with the outboard side facing up.
 - b. Obtain the TIMKEN SNAP RING REMOVER/INSTALLER (HD-44069).
 - c. With the gap in the snap ring being the 12 o'clock position, place the two claws so that the slotted sides engage the inside edge of the snap ring at the 10 and 2 o'clock positions.
 - d. Using a 9/64 inch allen head bit, tighten the screws to fix the position of the claws on the snap ring.
 - e. Inserting the tips of a large retaining ring pliers (Snap-On PR-56A) into one hole in each claw, compress the snap ring and install in groove of crankcase bore.
 - f. Verify that the gap in the snap ring is centered below the oil hole at the top of the ring groove. Move snap ring if not properly centered.
 - g. Loosen allen head screws and remove claws from snap ring

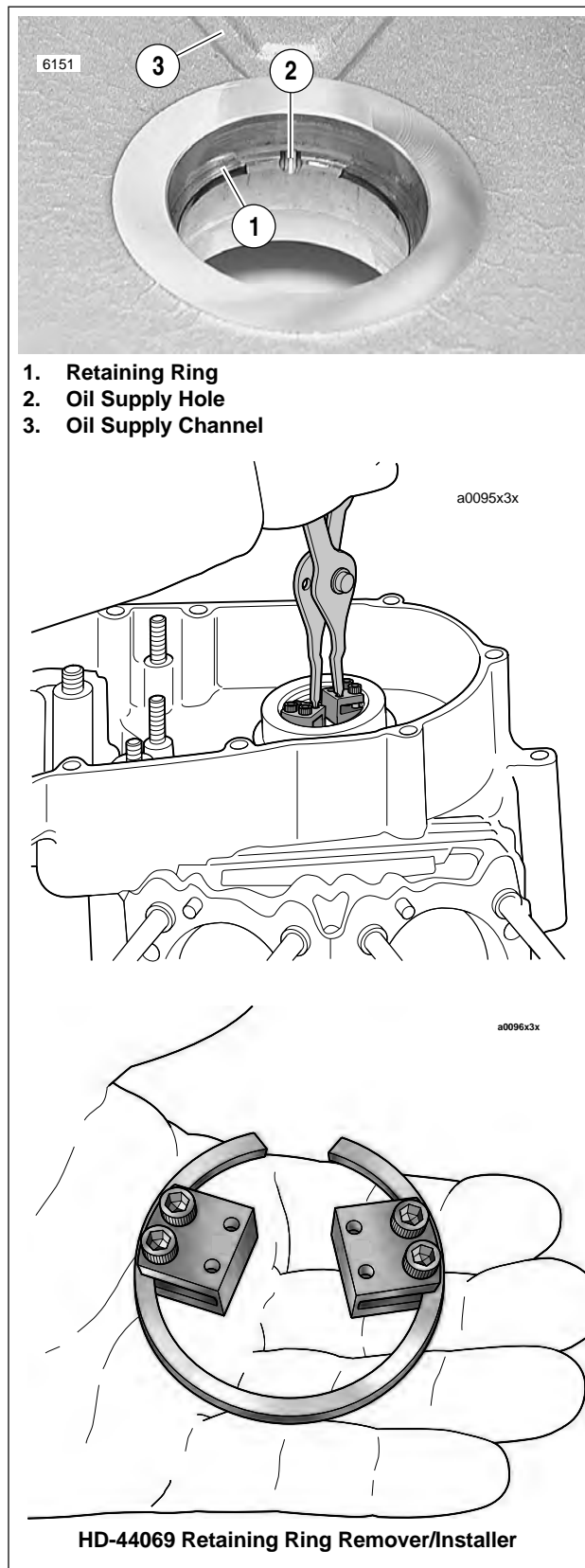

Figure 3-128. Snap Ring Installation

NOTE

See *Figure 3-129*. Use *SPROCKET SHAFT BEARING OUTER RACE INSTALLATION TOOL (Part No. HD-39458)* to install left and right outer races of sprocket shaft tapered roller bearings into left crankcase half. Always install left outer race prior to installing right outer race because the installer base is usable only when you follow this sequence of race installation.

2. Insert "SPORTSTER" end of installer base into inboard side of left crankcase half bearing bore until base contacts installed retaining ring.
3. Position left outer race over bearing bore on outboard side of left crankcase half.
4. Insert shaft of installer plug through left outer race and into installer base. Press race into bore until firmly seated against retaining ring.
5. Insert "SPORTSTER" end of installer base into outboard side of left crankcase half bearing bore until base contacts outboard surface of installed left outer race.
6. Position right outer race over bearing bore on inboard side of left crankcase half.
7. See *Figure 3-129*. Insert shaft of installer plug through right outer race and into installer base. Press race into bore until firmly seated against retaining ring.

NOTE

See *Figure 3-129*. Use *SPROCKET SHAFT BEARING/SEAL INSTALLATION TOOL (Part No. HD-42579)* to install sprocket shaft tapered roller bearings and seal.

8. See *Figure 3-129*. Install inner bearing.
 - a. Place **new** bearing, small end upward, over end of sprocket shaft.
 - b. Thread pilot onto sprocket shaft until pilot bottoms on sprocket shaft shoulder.
 - c. Sparingly apply graphite lubricant to threads of pilot shaft to ensure smooth operation.
 - d. Slide sleeve over pilot until sleeve contacts inner bearing race. Install Nice bearing, washer and handle on top of sleeve.
 - e. Rotate handle clockwise until bearing contacts fly-wheel shoulder. Remove tool from sprocket shaft.

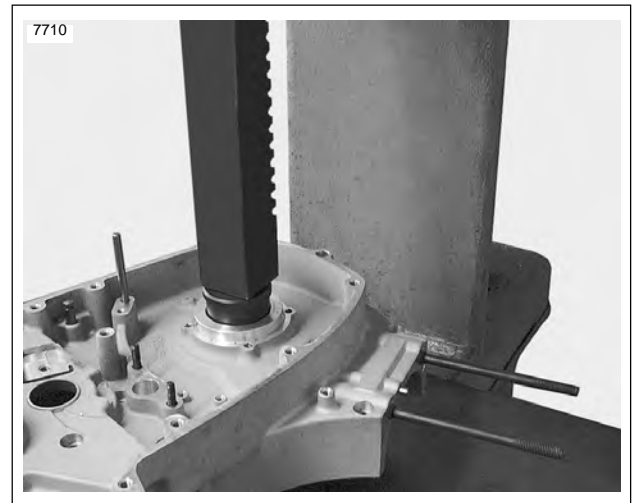

Figure 3-129. Left Outer Race Bearing Installation

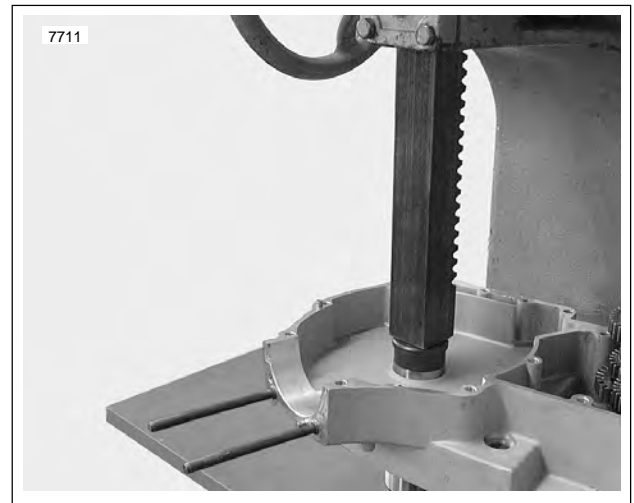

Figure 3-130. Right Outer Race Bearing Installation

9. See [Figure 3-132](#). Install shim and outer bearing.
 - a. Carefully place crankcase half over sprocket shaft so that it rests flat on inner bearing.
 - b. Slide **new** inner spacer over sprocket shaft until it contacts inner bearing race.
 - c. Place **new** outer bearing, small end downward, over sprocket shaft.
 - d. Assemble Sprocket Shaft Bearing/Seal Installation Tool (Part No. HD-42579) onto sprocket shaft. Follow procedure in Step 8.
 - e. Rotate handle clockwise until bearing firmly contacts inner spacer. Inner and outer bearings must be tight against inner spacer for correct bearing clearance. Remove tool from sprocket shaft.
 - f. Spin crankcase half to verify that flywheel assembly is free.
10. See [Figure 3-133](#). Install **new** spacer in seal ID. With the open (lipped) side facing outward, center seal/spacer assembly over bearing bore.

Do not remove the spacer after installation or the new seal will have to be discarded and the procedure repeated.

11. See [Figure 3-133](#). Install bearing seal and spacer.
 - a. Center seal/spacer driver over seal, so that the sleeve (smaller OD) seats between seal wall and garter spring.
 - b. Assemble Sprocket Shaft Bearing/Seal Installation Tool (1) (Part No. HD-42579) and SPROCKET SHAFT SEAL/SPACER INSTALLER (Part No. HD-42774) onto sprocket shaft. Follow procedure in Step 8.
 - c. Rotate handle clockwise until the spacer makes contact with the bearing. Remove tool from sprocket shaft.

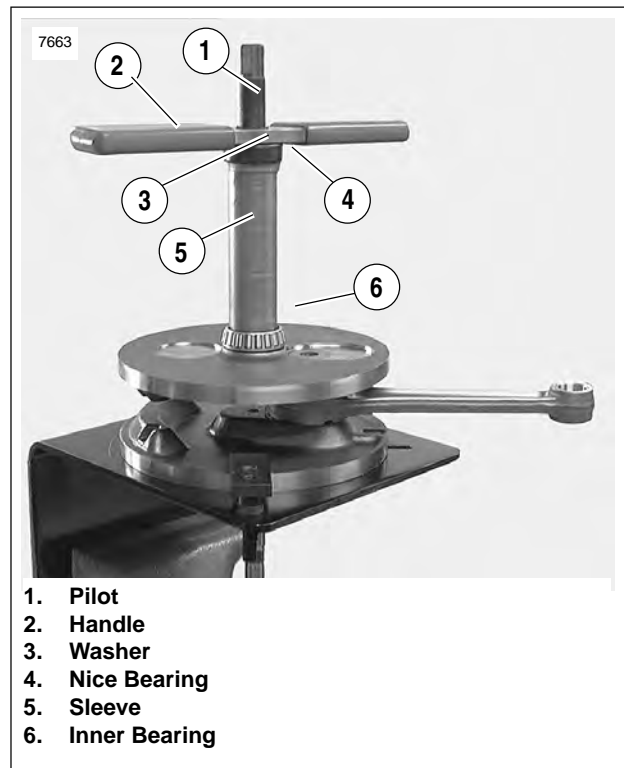

Figure 3-131. Inner Bearing Installation

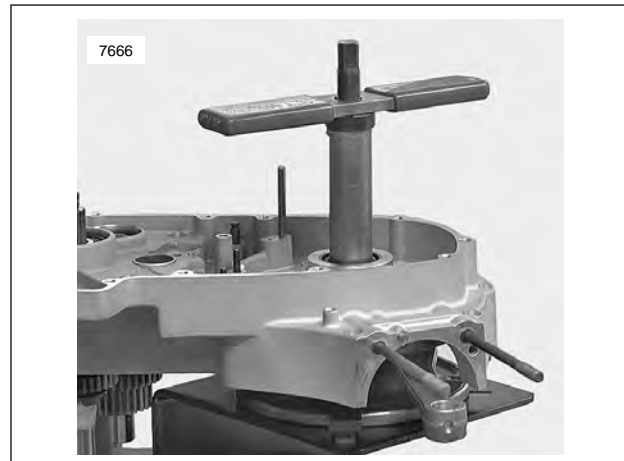

Figure 3-132. Installing Flywheel Spacer and Outer Bearing

12. See [Figure 3-134](#). Install pinion shaft bearing.
 - a. Lubricate pinion shaft bearing with engine oil.
 - b. Slip bearing on pinion shaft.
 - c. Install **new** retaining ring in groove of pinion shaft bearing inner race.
13. Install transmission. See [6.14 TRANSMISSION INSTALLATION](#).
14. Assemble crankcase halves together.
 - a. Apply a thin coat of DOW CORNING SILASTIC or 3-M 800 sealant to crankcase joint faces.
 - b. Slide pinion shaft through outer race in right crankcase.
 - c. Attach crankcase halves using hardware shown in [Figure 3-115](#).
 - d. Tighten the 5/1618 X 3-1/2 in. fasteners to 15-19 ft-lbs (20.3-25.8 Nm).
 - e. Tighten the 5/1618 X 2-1/2 in fasteners to 15-19 ft-lbs (20.3-25.8 Nm).
 - f. Tighten 3/8-in. fastener to 80-100 **in-lbs** (9.0-11.3 Nm).
15. See [Figure 3-135](#). Install cylinder studs.
 - a. Pack clean towels into crankcase opening.
 - b. Place a steel ball into a head screw.
 - c. The cylinder studs have a shoulder at the lower end. Place the end of the stud without the shoulder into the head screw.
 - d. Install the stud in the crankcase with the shoulder end down. Use an air gun to drive the stud until the shoulder reaches the crankcase.
 - e. Remove air gun. Use a torque wrench to tighten stud to 10-20 ft-lbs (13.6-27.1 Nm).
16. Install piston and cylinder. See [3.6 CYLINDER AND PISTON](#).
17. Install oil pump. See [3.13 OIL PUMP](#).
18. See [3.16 GEARCASE COVER AND CAM GEARS](#). Install cam gears, gearcase cover, lifter guides and lifters.
19. Install cylinder head. See [3.5 CYLINDER HEAD](#).
20. Install starter. See [5.7 STARTER](#).
21. Install shift linkage.
22. Install all primary drive components. This includes engine sprocket, primary chain, complete clutch assembly, engine sprocket nut and mainshaft nut. See [6.6 PRIMARY DRIVE/CLUTCH](#).
23. Install primary cover. See [6.2 PRIMARY CHAIN](#).

NOTE

See [1.10 TRANSMISSION/PRIMARY FLUID](#). Be sure to refill transmission to proper level with fresh lubricant.

24. See [3.4 ENGINE INSTALLATION](#) and perform the applicable steps.

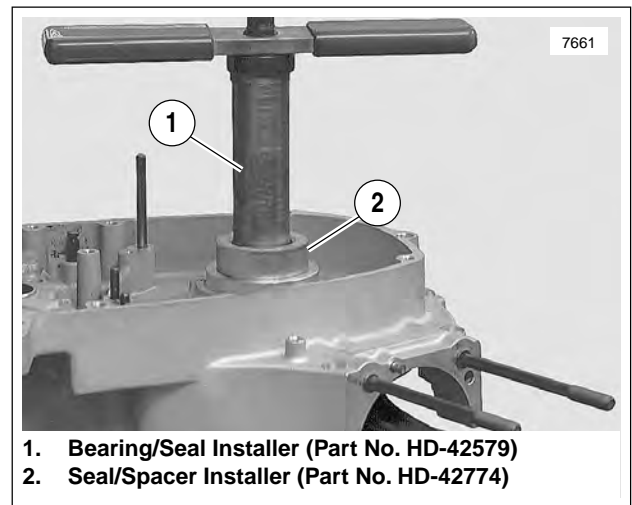

Figure 3-133. Install Bearing Seal/Spacer

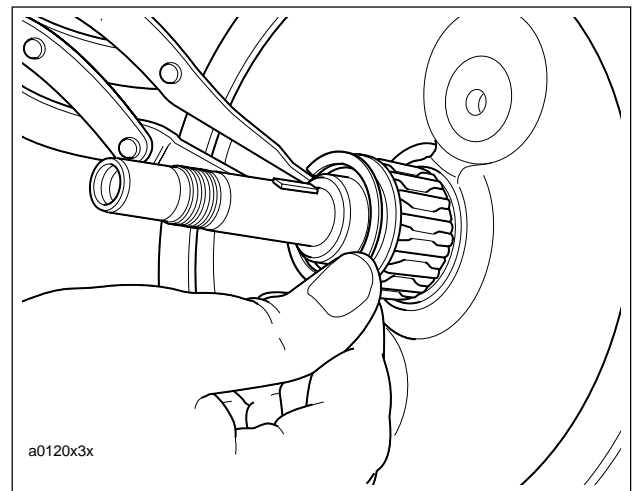

Figure 3-134. Pinion Shaft Bearing

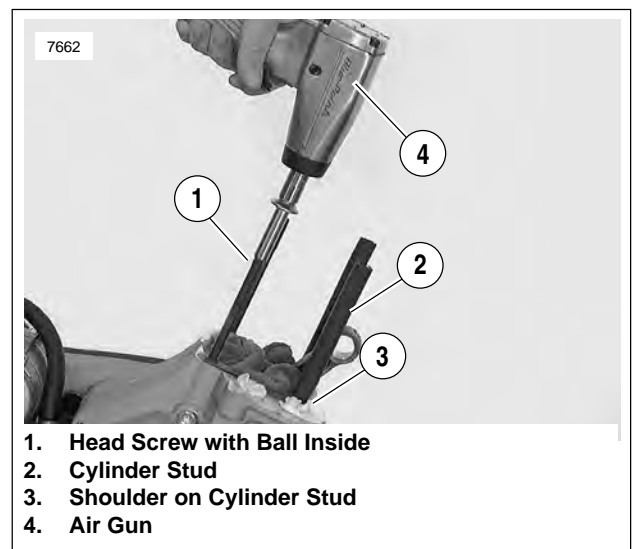

Figure 3-135. Cylinder Studs

NOTES

SUBJECT	PAGE NO.
4.1 Specifications	4-1
4.2 Tank Cover/Fuel Tank	4-5
4.3 Air Cleaner	4-12
4.4 Carburetor	4-15
4.5 Auto-Enrichener	4-22
4.6 Throttle Position Sensor	4-25
4.7 Evaporative Emissions Control System	4-27

FUEL TANK CAPACITY	U.S.	METRIC
Total (including reserve)	2.8 gallons	10.6 liters
Reserve	0.55 gallons	2.08 liters

CARBURETOR ADJUSTMENTS	
Engine Idle Speed (regular)	1200 RPM
Engine Idle Speed (fast)	2000 RPM

CARBURETOR JET SIZES	
Main Jet	165
Slow Jet	42

TORQUE VALUES		
Fastener Location	Torque Value	Locking Compound
Battery Cables to Terminals	60-96 in-lbs (6.8-10.9 Nm)	-
Fuel Valve to Fuel Tank	12-14 in-lbs (1.4-1.6 Nm)	
Fuel Cap Flange to Fuel Tank	20-22 in-lbs (2.3-2.5 Nm)	
Vent Tube Fitting	40-60 in-lbs (4.5-6.8 Nm)	
Throttle Position Sensor	13-23 in-lbs (1.5-2.6 Nm)	
Enrichener Stay Plate	13-23 in-lbs (1.5-2.6 Nm)	
Fuel Tank to T-shaped Bracket	4-6 ft-lbs (5.4-8.1 Nm)	
Tank Cover to T-shaped Bracket	30-36 in-lbs (3.4-4.1 Nm)	
10mm Nut (Bottom of Fuel Cap)	Variable Torque	
Triangular Bracket to Air Box	3-5 ft-lbs (4.1-6.8 Nm)	
Venturi Ring to Carburetor Flange	18-22 in-lbs (2.0-2.5 Nm)	LOCTITE THREADLOCKER 243 (Blue)
Air Box to Crankcase	10-12 ft-lbs (13.6-16.3 Nm)	LOCTITE THREADLOCKER 262 (Red)
Air Box Cover to Air Box	4-6 in-lbs (0.5-0.7 Nm)	-
Facia Cover	30-36 in-lbs (3.4-4.1 Nm)	
Charcoal Canister Bracket to Frame	30-36 in-lbs (3.4-4.1 Nm)	

Table 4-1. Fuel System Troubleshooting

OVERFLOW TROUBLESHOOTING	
Check for: <ol style="list-style-type: none"> 1. Restricted fuel tank vent system. 2. Loose float bowl screws. 3. Damaged float bowl O-ring. 4. Damaged or leaking float assembly. 5. Particle contamination in fuel inlet fitting cavity. 6. Worn or dirty inlet valve or seat. 7. Improper fuel level in float bowl. 	Remedy: <ol style="list-style-type: none"> 1. Correct restricted hose. Replace vapor vent valve. 2. Tighten screws. 3. Replace O-ring. 4. Replace float assembly. 5. Clean and clear cavity and fuel supply tract. 6. Clean or replace valve and clean seat. 7. Adjust float tab for correct fuel level.
POOR IDLING	
Check for: <ol style="list-style-type: none"> 1. Idle speed improperly adjusted. 2. Inlet system air leak (faster idling). 3. Loose low speed jet. 4. Contaminated or plugged low speed system. 5. Enrichener valve not seated or leaking. 	Remedy: <ol style="list-style-type: none"> 1. Adjust operating idle speed. 2. Correct as required. 3. Tighten jet. 4. Clean, clear and correct as required. 5. Adjust, clean or replace.
POOR FUEL ECONOMY	
Check for: <ol style="list-style-type: none"> 1. Enrichener valve not seated or leaking. 2. Dirty air cleaner filter element. 3. Restricted fuel tank vent system. 4. High speed riding style. 5. Idle speed improperly adjusted. 6. Loose jets. 7. Fuel level too high. 8. Plugged or restricted bowl vent. 9. Worn or damaged needle or needle jet. 10. Vacuum piston assembly malfunction. 11. Plugged air jets or passages. 	Remedy: <ol style="list-style-type: none"> 1. Adjust, clean or replace. 2. Replace as required. 3. Correct restricted hose. Replace vapor vent valve. 4. Modify riding habits. 5. Adjust operating idle speed. 6. Tighten jets. 7. Adjust float tab for correct fuel level. 8. Clean and clear passages. 9. Replace needle or needle jet. 10. See Table 4-2. 11. Clean, clear and correct as required.
POOR ACCELERATION	
Check for: <ol style="list-style-type: none"> 1. Throttle cables misaligned. 2. Inlet system air leak. 3. Restricted fuel tank vent system. 4. Restricted fuel supply passages. 5. Plugged bowl vent or overflow. 6. Enrichener valve not seated or leaking. 7. Worn or damaged needle or needle jet. 8. Vacuum piston malfunction. 9. Plugged jets or passages. 10. Fuel level too low. 	Remedy: <ol style="list-style-type: none"> 1. Adjust throttle cables. 2. Correct as required. 3. Correct restricted hose. Replace vapor vent valve. 4. Correct and clear restriction. 5. Clean and clear passages. 6. Adjust, clean or replace. 7. Replace assembly. 8. See Table 4-2. 9. Clean and clear as required. 10. Adjust float tab for correct fuel level.
HARD STARTING	

OVERFLOW TROUBLESHOOTING	
Check for: <ol style="list-style-type: none"> 1. Enrichener system plugged, not properly functioning or improperly operated. 2. Inlet system air leak. 3. Restricted fuel supply. 4. Fuel overflow. 5. Plugged slow jet or passages. 	Remedy: <ol style="list-style-type: none"> 1. Clean, adjust or replace. 2. Correct as required. 3. Correct fuel supply or passages. 4. See OVERFLOW TROUBLESHOOTING above. 5. Clean, clear and correct as required.

Table 4-2. Fuel System Troubleshooting

POOR PERFORMANCE ON ROAD	
Check for: <ol style="list-style-type: none"> 1. Idle speed improperly adjusted. 2. Inlet system air leak. 3. Restricted fuel tank vent system. 4. Dirty or damaged air cleaner element. 5. Enrichener valve not seated or leaking. 6. Restricted fuel supply tract. 7. Plugged bowl vent or overflow. 8. Loose or plugged fuel and air jets or passages. 9. Worn or damaged needle or needle jet. 10. Vacuum piston assembly malfunction. 	Remedy: <ol style="list-style-type: none"> 1. Adjust operating idle speed. 2. Correct as required. 3. Correct restricted hose. Replace vapor vent valve. 4. Replace. 5. Adjust, clean or replace. 6. Correct and clear restriction. 7. Clean and clear passages. 8. Clean, clear and correct as required. 9. Replace assembly. 10. See Table 4-2.
POOR HIGH-SPEED PERFORMANCE	
Check for: <ol style="list-style-type: none"> 1. Inlet system air leak. 2. Enrichener valve not seated or leaking. 3. Restricted fuel tank vent system. 4. Restricted fuel supply tract. 5. Dirty or damaged air cleaner element. 6. Plugged bowl, vent or overflow. 7. Worn or damaged needle or needle jet. 8. Vacuum piston assembly malfunction. 9. Loose or plugged main jets or passages. 10. Improper fuel level. 	Remedy: <ol style="list-style-type: none"> 1. Clean or replace. 2. Adjust, clean or replace. 3. Correct restricted hose. Replace vapor vent valve. 4. Correct and clean restriction. 5. Replace. 6. Clean and clear passages. 7. Replace assembly. 8. See Table 4-2. 9. Clean, clear and correct as required. 10. Adjust float level.

Vacuum Piston Assembly Troubleshooting

PISTON DOES NOT RISE PROPERLY	
Check for: <ol style="list-style-type: none">1. Piston atmosphere vent blocked.2. Diaphragm cap loose, damaged or leaking.3. Spring binding.4. Diaphragm pinched at lip groove.5. Torn diaphragm.6. Piston binding.7. Piston vacuum passage plugged.	Remedy: <ol style="list-style-type: none">1. Clear vent.2. Tighten or replace cap.3. Correct or replace spring.4. Reposition diaphragm lip.5. Replace piston diaphragm assembly.6. Clean piston slides and body or replace piston.7. Clean and clear passage.
PISTON DOES NOT CLOSE PROPERLY	
Check for: <ol style="list-style-type: none">1. Spring damaged.2. Piston binding.3. Piston diaphragm ring dirty or damaged.	Remedy: <ol style="list-style-type: none">1. Replace spring.2. Clean piston slides and body or replace piston.3. Clean or replace piston.

ASSEMBLY REMOVAL

Fuel Tank Cover

⚠ WARNING

Gasoline is extremely flammable and highly explosive. When servicing the fuel system, do not smoke or allow open flame or sparks in the vicinity. Inadequate safety precautions could result in death or serious injury.

1. Remove seat. Depress latch at bottom and pull seat up and back to remove. See [Figure 4-1](#).

⚠ WARNING

To protect against shock and accidental start-up of vehicle, disconnect the negative battery cable before proceeding. Inadequate safety precautions could result in death or serious injury.

2. Unthread bolt and remove battery negative cable (black) from battery negative (-) terminal.
3. At rear of fuel tank, remove flange bolt (with nylon washer) to release tank cover from clip nut on T-shaped mounting bracket. See **A** of [Figure 4-2](#).
4. Carefully cut small cable strap and pull vent tube from fitting at front of fuel cap flange.
5. Remove oil dipstick from threaded hole in frame backbone (just rear of steering head). Remove mounting ring from around threaded hole.
6. Remove tank cover and set aside.
7. Install oil dipstick back into threaded hole in frame backbone.

Fuel Tank

8. Rotate the 3-position valve handle on the fuel valve to the fully vertical position to shut the gasoline supply to the carburetor OFF. See **A** of [Figure 4-5](#).

⚠ WARNING

Some gasoline will drain from the outlet hose when disconnected from the fuel valve. Thoroughly wipe up any spilt fuel immediately. Dispose of rags in a suitable manner. Gasoline is extremely flammable and highly explosive. Inadequate safety precautions could result in death or serious injury.

9. Turn slotted screw to loosen band clamp on outlet fitting at side of fuel valve. Pull hose from fitting.
10. At rear of fuel tank, remove remaining two flange bolts to release T-shaped mounting bracket from frame backbone. See **B** of [Figure 4-2](#).
11. Remove left side airbox cover. See [4.3 AIR CLEANER](#).
12. Moving to front of vehicle, pry rubber stops from weld studs on each side of frame backbone. See **A** and **B** of [Figure 4-3](#).

13. Raise rear of fuel tank and slide assembly rearward to remove from frame.

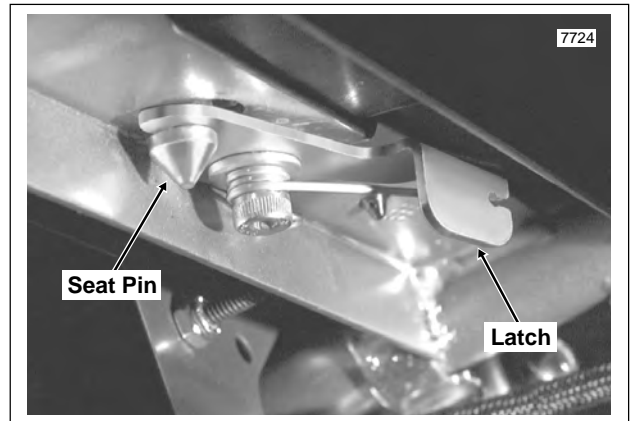

Figure 4-1. Remove Seat

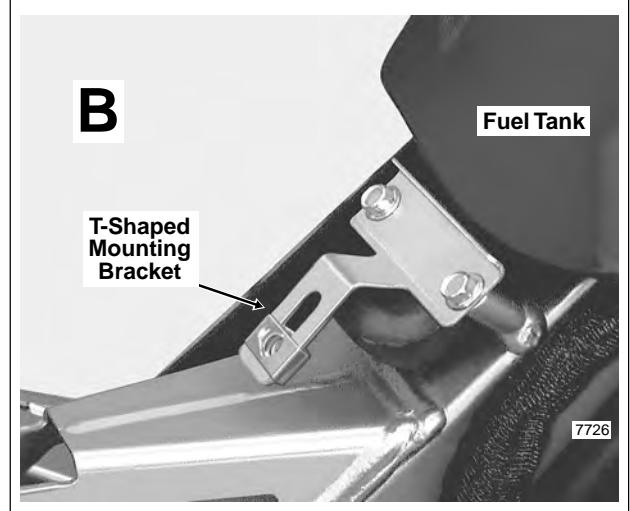
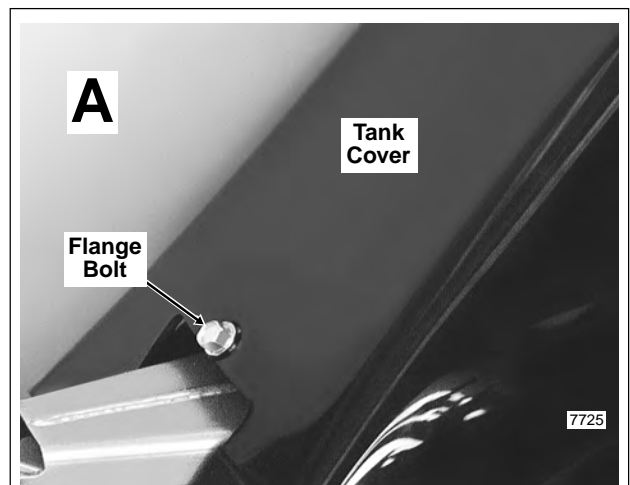

Figure 4-2. Remove Tank Cover Fuel Tank

ASSEMBLY INSTALLATION

Fuel Tank

1. Place fuel tank into position on frame backbone.
2. Standing at front of vehicle, push rubber stops onto weld studs on each side of frame backbone. Using a rubber mallet, tap stops until fully seated. See A and B of [Figure 4-3](#).
3. With the lipped side up, slide two flange bolts through forward holes in T-shaped mounting bracket. Pushing down on rear of tank, start flange bolts into bosses in frame backbone. Alternately tighten flange bolts to 4-6 ft-lbs (5.4-8.1 Nm). See B of [Figure 4-2](#).
4. Install airbox cover on left hand side. See [4.3 AIR CLEANER](#).
5. Push hose onto outlet fitting at side of fuel valve. Turn slotted screw to tighten band clamp.

Fuel Tank Cover

6. Remove oil dipstick from threaded hole in frame backbone (just rear of steering head).
7. Install tank cover.
8. At rear of fuel tank, install rear flange bolt (with nylon washer) to fasten tank cover to clip nut on T-shaped mounting bracket. Tighten flange bolt to 30-36 **in-lbs** (3.4-4.1 Nm). See A of [Figure 4-2](#).
9. With the lipped side up, place mounting ring over threaded hole in frame backbone. Install oil dipstick into hole.
10. Push vent tube onto nozzle of vent tube fitting. Install small cable strap to fix location. Cut any excess cable strap material.
11. Insert bolt through battery negative cable (black) into threaded hole of battery negative (-) terminal. Tighten bolt to 60-96 **in-lbs** (6.8-10.9 Nm).
12. Position seat on frame backbone, so that tongue at bottom engages slot in frame weldment. Push down on rear of seat until spring-loaded latch fully engages groove of seat pin.

WARNING

Pull up on seat to verify that it is properly secured, front and rear. A loose seat may shift during vehicle operation and startle the rider, possibly causing loss of vehicle control that could result in death or serious injury.

FUEL CAP

Removal

1. Locate the fuel filler cap at the top of the fuel tank.
1. Insert finger into depression and lift the locking tab up, so that it is perpendicular to the fuel filler cap.
2. Rotate the locking tab 1/4 turn in a counter-clockwise direction.
3. Pull locking tab to remove fuel filler cap from tank.

4. Observe the warning label at the top of the fuel tank. When refueling, keep fuel level at least one inch below bottom of fuel cap boot. See A of [Figure 4-4](#).

WARNING

Remove the fuel filler cap slowly. Fill fuel tank slowly to prevent fuel spillage. Observe the warning label at the top of the tank. Keep fuel level at least one inch below bottom of fuel cap boot. This allows sufficient air space for fuel expansion. Expansion can cause an overfilled tank to overflow fuel through the filler cap vent onto surrounding areas. After refueling, be sure filler cap is securely tightened. Gasoline is extremely flammable and highly explosive. Inadequate safety precautions could result in death or serious injury.

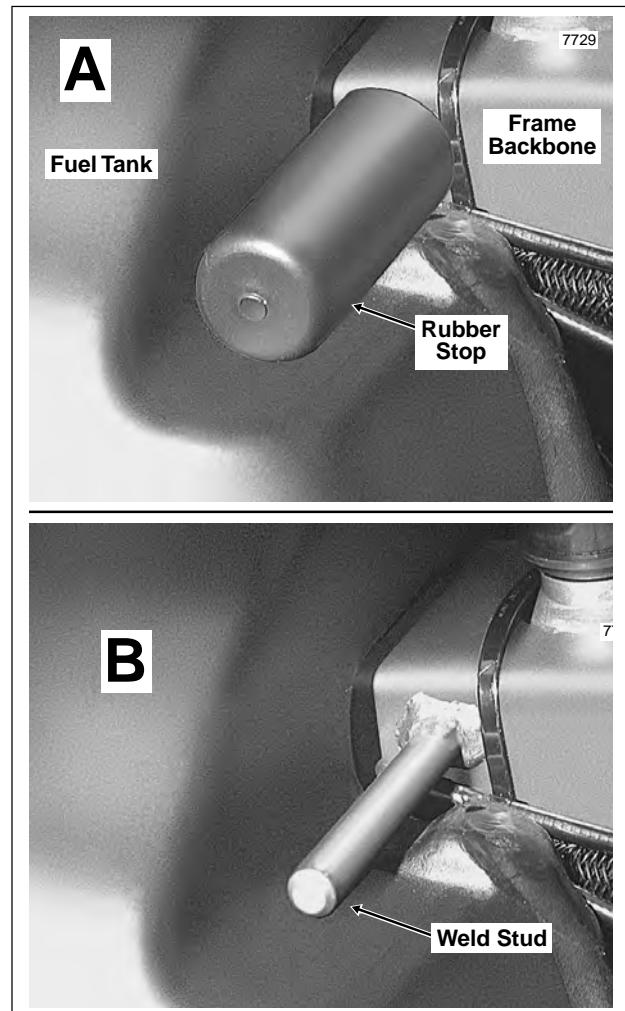

Figure 4-3. Remove Fuel Tank

Installation

1. Inspect O-ring at underside of fuel filler cap for cuts, tears or signs of deterioration. Replace if necessary. See B of [Figure 4-4](#).
2. Place fuel filler cap into tank with the depression at the front.
3. Rotate the locking tab 1/4 turn in a clockwise direction.

- Push locking tab down, so that it is flush with the fuel filler cap.

NOTE

Locking tab should snap down tightly, but not so tight that it becomes too difficult to remove. To increase or decrease the tension required to operate the locking tab, turn the fuel filler cap over and either loosen or tighten the 10mm nut. See B of Figure 4-4.

FUEL SUPPLY VALVE

Operation

The fuel supply valve is located under the fuel tank on the left side of the vehicle. The gasoline supply to the carburetor is dependent upon the position of the valve handle. See upper frame of Figure 4-5.

Turning the 3-position valve handle to the fully vertical position shuts the gasoline supply to the carburetor OFF. Moving the valve handle counter-clockwise to the horizontal position turns the main fuel supply ON. Turning the handle clockwise to the horizontal position accesses the RES(ERVE) supply. See Figure 4-5.

⚠ WARNING

To prevent accidental flooding of the engine or surrounding area with gasoline, always turn the fuel supply valve to OFF when the engine is not running. Gasoline is extremely flammable and highly explosive. Inadequate safety precautions could result in death or serious injury.

NOTE

To maintain a reserve supply, do not operate the motorcycle with the valve in the RES(ERVE) position after refueling.

Removal

NOTE

Clean or replace fuel filter strainer every 20,000 miles.

⚠ WARNING

Gasoline is extremely flammable and highly explosive. When servicing the fuel system, do not smoke or allow open flame or sparks in the vicinity. Inadequate safety precautions could result in death or serious injury.

- Remove seat. Depress latch at bottom and pull seat up and back to remove. See Figure 4-1.

⚠ WARNING

To protect against shock and accidental start-up of vehicle, disconnect the negative battery cable before proceeding. Inadequate safety precautions could result in death or serious injury.

- Unthread bolt and remove battery negative cable (black) from battery negative (-) terminal.
- Drain fuel tank as follows:

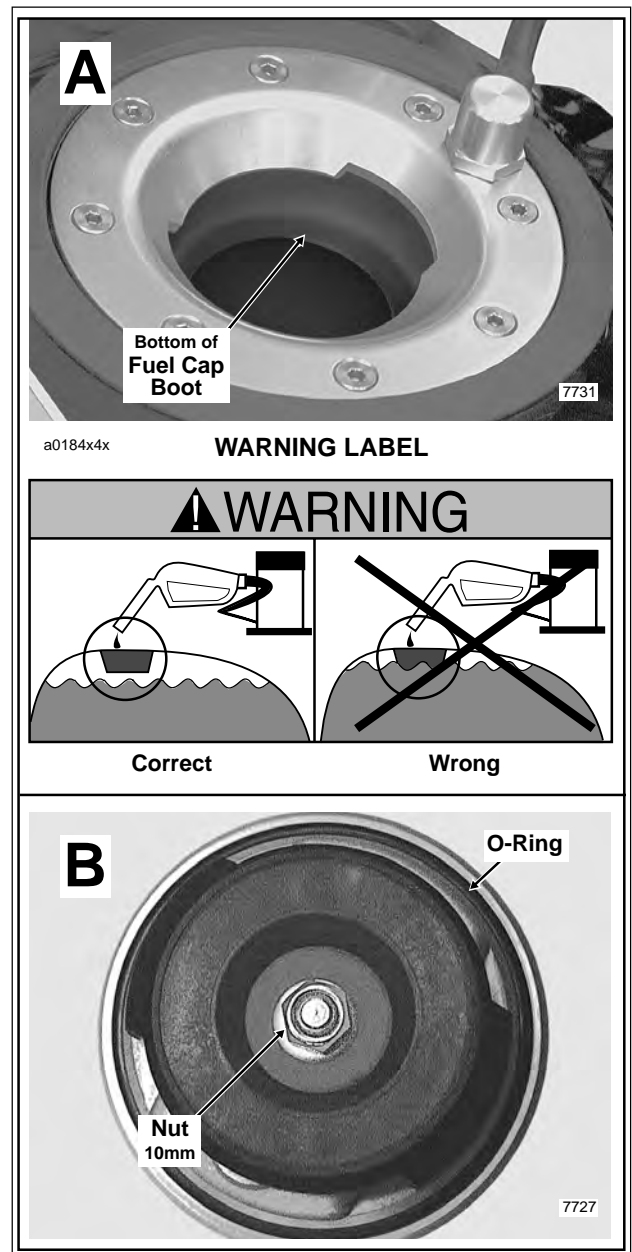

Figure 4-4. Remove Tank Cover/Fuel Tank

- Rotate handle on the fuel supply valve to the fully vertical position to shut the gasoline supply to the carburetor OFF. See A of Figure 4-5.
- Some gasoline will drain from the outlet hose when disconnected from the fuel valve. Thoroughly wipe up any spilt fuel immediately. Dispose of rags in a suitable manner. Gasoline is extremely flammable and highly explosive. Inadequate safety precautions could result in death or serious injury.
- Turn slotted screw to loosen band clamp on outlet fitting at side of fuel valve. Pull hose from fitting.
- Attach length of spare hose to outlet fitting. Place free end of hose into a suitable container.
- Rotate handle of fuel supply valve to RES(ERVE) to start the flow of fuel. See C of Figure 4-5.

- f. Once the fuel tank is completely drained, rotate handle of fuel supply valve to OFF. Remove spare hose from outlet fitting.

WARNING

Even with the fuel tank completely drained, a small amount of gasoline may leak from the bore when the fuel supply valve is loosened or removed. Thoroughly wipe up any spilt fuel immediately. Dispose of rags in a suitable manner. Gasoline is extremely flammable and highly explosive. Inadequate safety precautions could result in death or serious injury.

4. Remove two allen head screws from fuel valve and pull assembly from fuel tank bore.
5. Remove O-ring from flange of fuel valve assembly. Discard O-ring.
6. Carefully unthread fuel filter strainer from fuel valve assembly. Clean strainer using a suitable solvent. Discard strainer if any damage is found.

Installation

1. Carefully thread fuel filter strainer onto fuel valve assembly.
2. Install **new** O-ring into groove on flange of fuel valve assembly.
3. Insert fuel valve assembly into fuel tank bore and install two allen head screws. Alternately tighten screws to 12-14 **in-lbs** (1.4-1.6 Nm).
4. Push hose onto outlet fitting at side of fuel valve. Turn slotted screw to tighten band clamp.
5. Verify that handle of fuel supply valve is in the OFF position and fill the fuel tank.
6. Rotate handle of fuel supply valve to ON and carefully inspect for leaks. Return the valve to the OFF position when finished.
7. Insert bolt through battery negative cable (black) into threaded hole of battery negative (-) terminal. Tighten bolt to 60-96 **in-lbs** (6.8-10.9 Nm).
8. Position seat on frame backbone, so that tongue at bottom engages slot in frame weldment. Push down on rear of seat until spring-loaded latch fully engages groove of seat pin.

WARNING

Pull up on seat to verify that it is properly secured, front and rear. A loose seat may shift during vehicle operation and startle the rider, possibly causing loss of vehicle control that could result in death or serious injury.

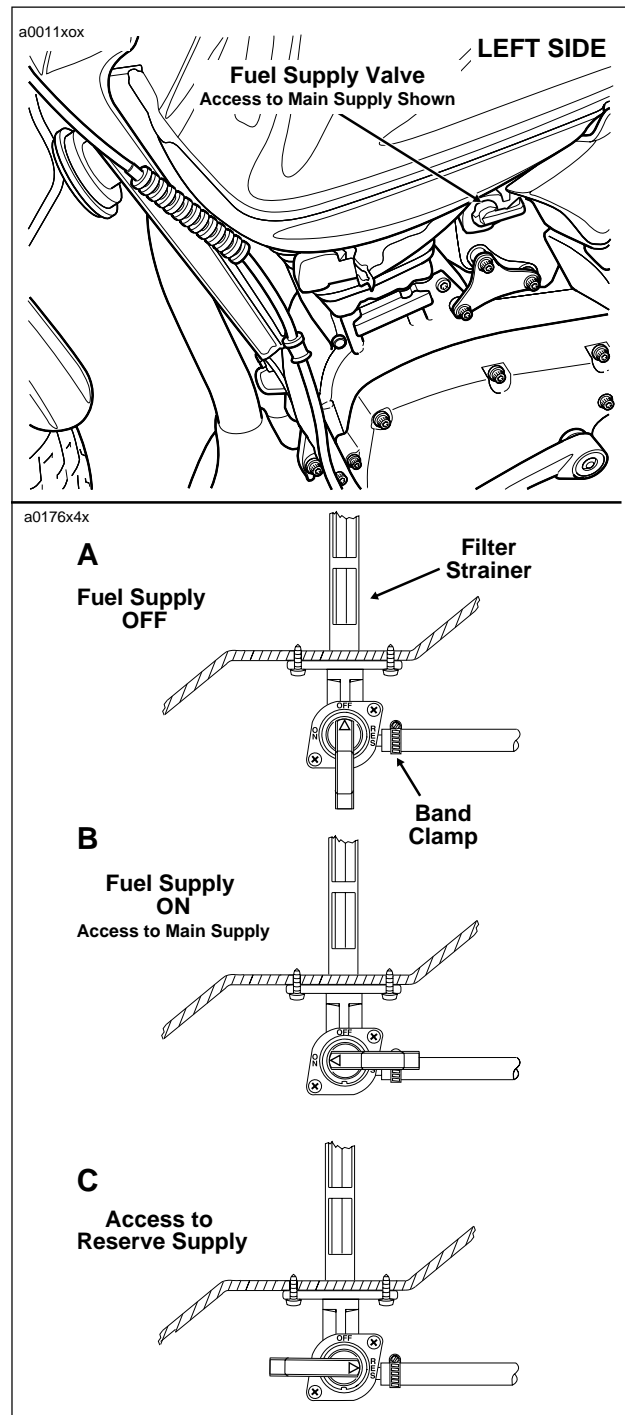

Figure 4-5. Fuel Supply Valve

ROLLOVER VALVE

Removal

WARNING

Gasoline is extremely flammable and highly explosive. When servicing the fuel system, do not smoke or allow open flame or sparks in the vicinity. Inadequate safety precautions could result in death or serious injury.

1. Remove seat. Depress latch at bottom and pull seat up and back to remove. See Figure 4-1.

WARNING

To protect against shock and accidental start-up of vehicle, disconnect the negative battery cable before proceeding. Inadequate safety precautions could result in death or serious injury.

2. Unthread bolt and remove battery negative cable (black) from battery negative (-) terminal.
3. Drain fuel tank as follows:
 - a. Rotate handle on the fuel supply valve to the fully vertical position to shut the gasoline supply to the carburetor OFF. See A of Figure 4-5.

WARNING

Some gasoline will drain from the outlet hose when disconnected from the fuel valve. Thoroughly wipe up any spilt fuel immediately. Dispose of rags in a suitable manner. Gasoline is extremely flammable and highly explosive. Inadequate safety precautions could result in death or serious injury.

- b. Turn slotted screw to loosen band clamp on outlet fitting at side of fuel valve. Pull hose from fitting.
 - c. Attach length of spare hose to outlet fitting. Place free end of hose into a suitable container.
 - d. Rotate handle of fuel supply valve to RES(ERVE) to start the flow of fuel. See C of Figure 4-5.
 - e. Once the fuel tank is completely drained, rotate handle of fuel supply valve to OFF. Remove spare hose from outlet fitting.
4. Insert finger into depression at top of fuel filler cap and lift the locking tab up. Rotate tab 1/4 turn in a counter-clockwise direction, and then pull to remove fuel filler cap from tank.
 5. Carefully cut small cable strap and pull vent tube from fitting at front of fuel cap flange.
 6. Alternately loosen and remove eight fuel cap flange screws in a crosswise pattern. See Figure 4-7.
 7. Insert fingers into filler neck and under fuel cap boot to hold bottom of rollover valve. Rotate hex on vent tube fitting in a counter-clockwise direction and remove.
 8. Keeping fingers at bottom of rollover valve, push on threaded end to remove from holes in fuel cap flange and boot. See A of Figure 4-8. Remove fuel cap flange and boot from fuel tank.

a0177x4x

VEHICLE UPRIGHT

Check ball holds post to one side allowing hydrocarbon vapors to be released to the atmosphere or charcoal canister (California)

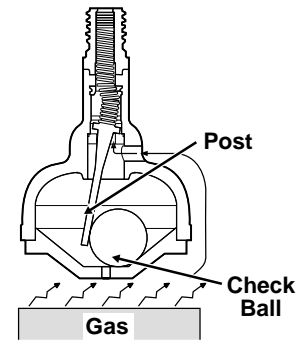

VEHICLE TIPPED

Without influence of check ball, spring forces post to seal opening preventing loss of gasoline through the vent tube.

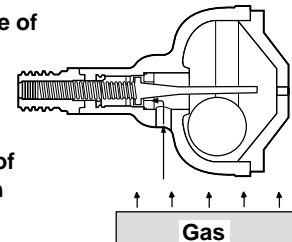

Figure 4-6. Rollover Valve

a0178x4x

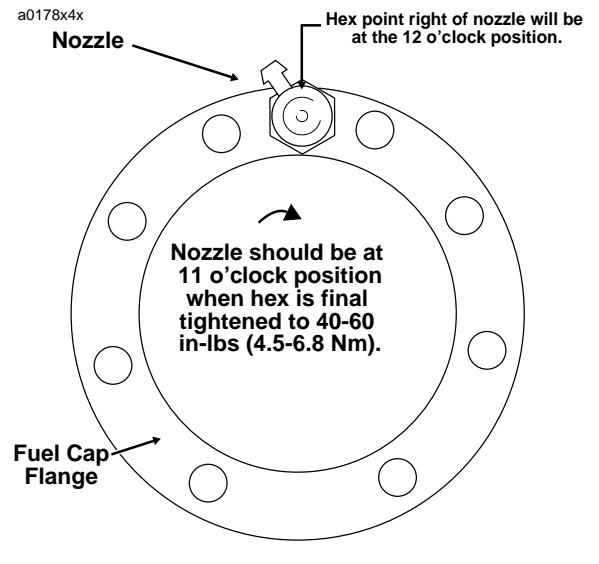

Figure 4-7. Filler Cap Flange Torque Sequence and Vent Tube Fitting Orientation

9. Maintaining hold of rollover valve, remove from hole in fuel tank. See B of Figure 4-8. Exercise caution to avoid dropping valve into fuel tank.
10. Remove O-ring from groove in vent tube fitting. Discard O-ring.
11. Clean old HYLOMAR material from both sides of fuel cap boot, top of fuel tank, and bottom of fuel cap flange.

Installation

1. Install **new** O-ring into groove of vent tube fitting.
2. Spread HYLOMAR on both sides of fuel cap boot confining application to where boot makes contact with top of fuel tank and bottom of fuel cap flange.
3. Holding rollover valve in a vertical position with the threaded end at the top, insert into filler neck pushing threaded end up through hole in fuel tank. See B of Figure 4-8. Exercise caution to avoid dropping valve into fuel tank.
4. With hole in boot aligned with hole in fuel cap flange, place over threaded end of rollover valve. Start vent tube fitting onto threads of rollover valve, but do not tighten.
5. Using a crosswise pattern, alternately tighten eight fuel cap flange screws until snug. See Figure 4-7. Following the same pattern, final tighten screws to 20-22 **in-lbs** (2.3-2.5 Nm).
6. Hand tighten vent tube fitting, so that nozzle is at the 11 o'clock position (with hex point to the right of the nozzle at 12 o'clock). See Figure 4-7.

NOTE

If nozzle is not at the 11 o'clock position when hand tightened, loosen the fitting slightly, and reaching into filler neck with two fingers, slightly rotate body of rollover valve in a counter-clockwise direction. Hand tighten fitting again and observe orientation of nozzle. If nozzle is closer, repeat procedure. If further away, rotate body of valve in the opposite direction. A few attempts may be needed to achieve the desired result.

CAUTION

Do not overtighten vent tube fitting or attempt to tighten with standard "click-type" torque wrench. Overtightening fitting can snap off threaded end of rollover valve, possibly causing damaged parts to fall into fuel tank.

7. Using a dial-type torque wrench on hex, final tighten vent tube fitting to 40-60 **in-lbs** (4.5-6.8 Nm). Verify that nozzle has not rotated out of 11 o'clock position.
8. Push hose onto outlet fitting at side of fuel supply valve. Turn slotted screw to tighten band clamp.
9. Push vent tube onto nozzle of vent tube fitting. Install small cable strap to fix location. Cut any excess cable strap material.
10. Insert bolt through battery negative cable (black) into threaded hole of battery negative (-) terminal. Tighten bolt to 60-96 **in-lbs** (6.8-10.9 Nm).

WARNING

Pull up on seat to verify that it is properly secured, front and rear. A loose seat may shift during vehicle operation and startle the rider, possibly causing loss of vehicle control that could result in death or serious injury.

11. Position seat on frame backbone, so that tongue at bottom engages slot in frame weldment. Push down on rear of seat until spring-loaded latch fully engages groove of seat pin.
12. Verify that handle of fuel supply valve is in the OFF position and fill the fuel tank.

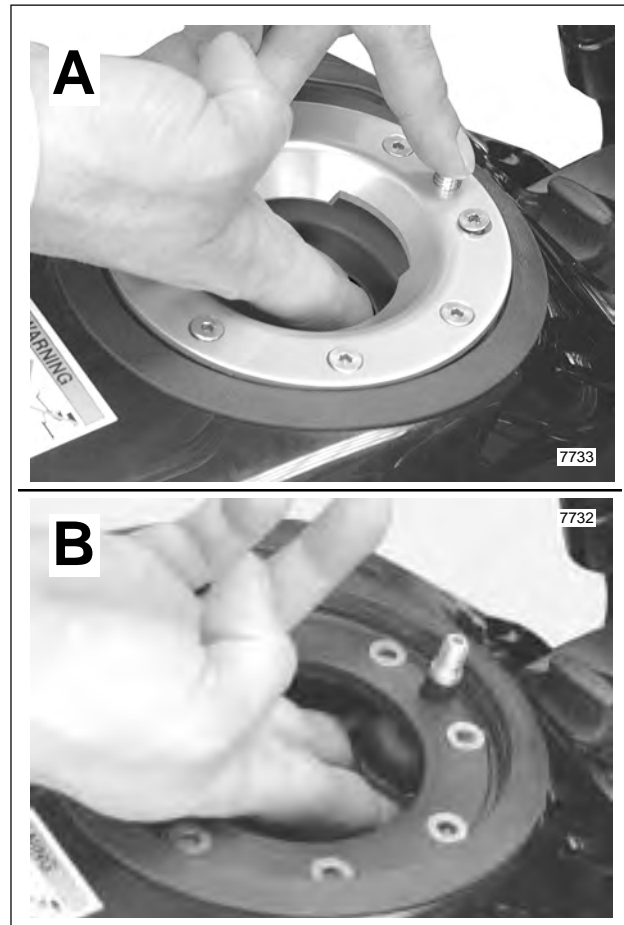

Figure 4-8. Remove Rollover Valve

13. Rotate handle of fuel supply valve to ON and carefully inspect for leaks. Return the valve to the OFF position when finished.

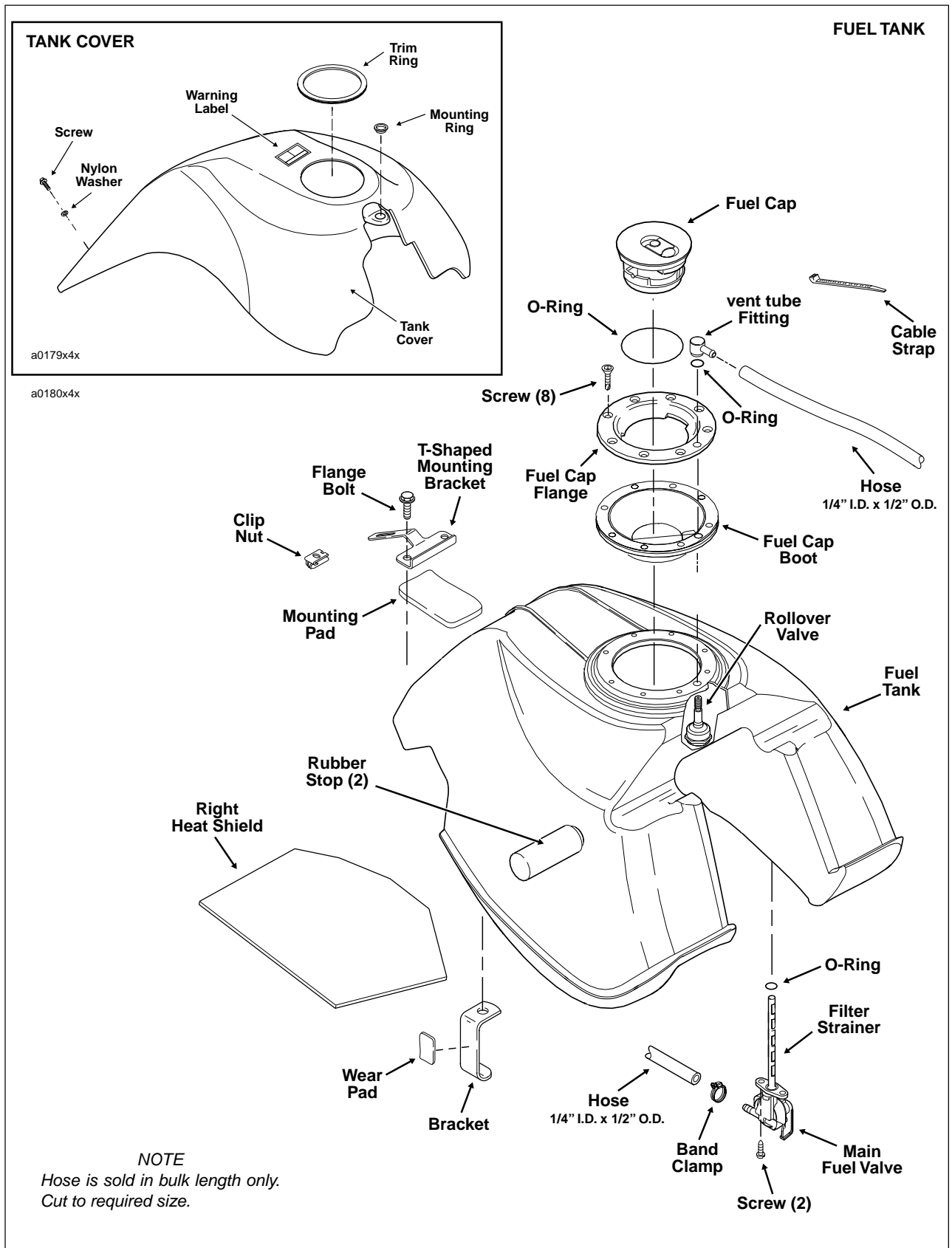

Figure 4-9. Fuel Tank Assembly

GENERAL

The air cleaner prevents foreign material from entering the carburetor and engine, trapping airborne dust and dirt in the filter element. Service the air cleaner filter element every 10,000 miles (16,000 km), or more often if the motorcycle is run in a dusty environment. Replace the element every 30,000 miles (48,000 km).

REMOVAL

1. Release five latches around perimeter of air box cover. See [Figure 4-11](#).
2. Remove single Phillips screw at bottom of air box cover (7 o'clock position).
3. Pull cover from air box.
4. Pull conical shaped filter from air box.
5. Squeeze wings on spring clamp with pliers and pull PCV outlet hose from fixed position on allen head screw (gold) at top of venturi ring. Remove screw with spacer.
6. Remove remaining two allen head screws to free venturi ring from carburetor flange.
7. Remove hex screw at bottom of air box (6 o'clock position) to release bracket from crankcase hole.
8. Moving to left side of vehicle, remove two flange bolts to release side of air box from triangular shaped bracket. Do not remove bottom bolt to crankcase. See [Figure 4-12](#).

CAUTION

Do not take bolt in and out of the crankcase unless necessary. Since the potential for stripping always exists during removal and installation, leave the bolt intact to avoid possible damage to the crankcase.

9. Returning to the right side of the vehicle, carefully pull out air box. When partially removed, detach PCV outlet hose from middle fitting on 3-way connector.
10. Remove gasket from inboard side of air box. Discard gasket.

CLEANING AND INSPECTION

1. Thoroughly clean air cleaner cover and backplate.
2. Replace the filter element if damaged or if filter media cannot be adequately cleaned.

WARNING

Do not use gasoline or solvents to clean the filter element. Volatile or flammable cleaning agents may cause an intake system fire, which could result in death or serious injury.

3. Wash the filter element (and hose connections) in warm, soapy water. To remove soot and carbon, soak element for 30 minutes in warm water with mild detergent.

WARNING

Compressed air can pierce the skin and cause injury. Never use your hand to check for leaks or to determine air flow rates. Wear safety glasses to shield your eyes from flying dirt and debris. Failure to comply could result in death or serious injury.

4. Dry the filter element using low pressure compressed air (32 psi/221 kPa maximum). Rotate the element while moving air nozzle up and down the element exterior. Do not rap the element on a hard surface.
5. Hold the filter element up to a strong light source. The element can be considered sufficiently clean if light is uniformly visible through the media.
6. Inspect all hose connections for cuts, tears, holes or signs of deterioration. Replace as necessary. Direct compressed air through hoses to verify that they are not plugged.

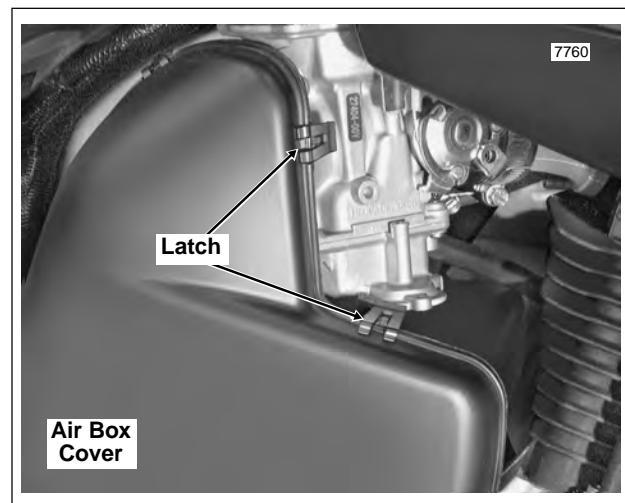

Figure 4-10. Release Air Box Cover Latches

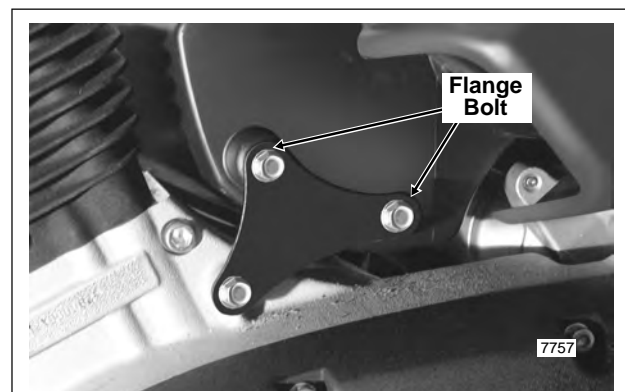

Figure 4-11. Remove Air Box From Bracket

INSTALLATION

1. Obtain a **new** carburetor gasket. Remove the protective paper and place the sticky side of the gasket against the back of the airbox. Use care to align the holes in the gasket with the slotted holes in the airbox.
2. Standing on the right side of the vehicle, start air box into opening below and to the rear of the carburetor. When partially installed, push PCV outlet hose onto middle fitting of 3-way connector.
3. Moving to opposite side of vehicle, apply a small dab of Loctite Low Strength Threadlocker 222 (Purple) to threads of two flange bolts. Slide bolts through top two holes of triangular bracket and install into left side of air box. Alternately tighten screws to 3-5 ft-lbs (4.1-6.8 Nm).
4. Returning to right side of vehicle, align slots in air box with holes in carburetor flange.
5. Apply a small dab of Loctite Medium Strength Threadlocker 243 (blue) to threads of two short allen head screws. With the flat edge at the top, align holes in venturi ring with holes in carburetor flange. Install screws in the 5 o'clock and 9 o'clock positions. Alternately tighten screws to 18-22 **in-lbs** (20.-2.5 Nm).
6. Slide spacer onto longer allen head screw (gold), if removed. Apply a small dab of Loctite Medium Strength Threadlocker 243 (blue) to threads of screw and install into remaining hole in venturi ring (2 o'clock position). Tighten screw to 18-22 **in-lbs** (20.-2.5 Nm).
7. Squeeze wings on spring clamp with pliers and push free end of PCV outlet hose over head of gold screw (and spacer) to fix position. See Figure 4-13.
8. Apply one drop of Loctite High Strength Threadlocker 262 (red) to threads of hex screw. Install screw at bottom of air box (6 o'clock position) to secure air box bracket to crankcase hole. Tighten screw to 10-12 ft-lbs (13.6-16.3 Nm).
9. With the larger OD inboard, install conical shaped filter into air box.
10. Taking note of index pin on inboard side of cover and small depression at tip of cone, position cover onto air box so that pin engages depression. See Figure 4-14.
11. Lock five latches around perimeter of air box cover.
12. Install Phillips screw at bottom of air box cover (7 o'clock position) to secure cover to air box. Tighten screw to 4-6 **in-lbs** (0.5-0.7 Nm).

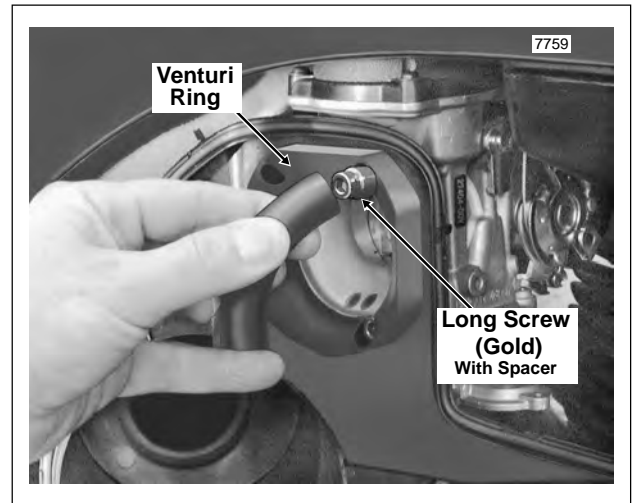

Figure 4-12. Fix Hose End Onto Allen Head Screw

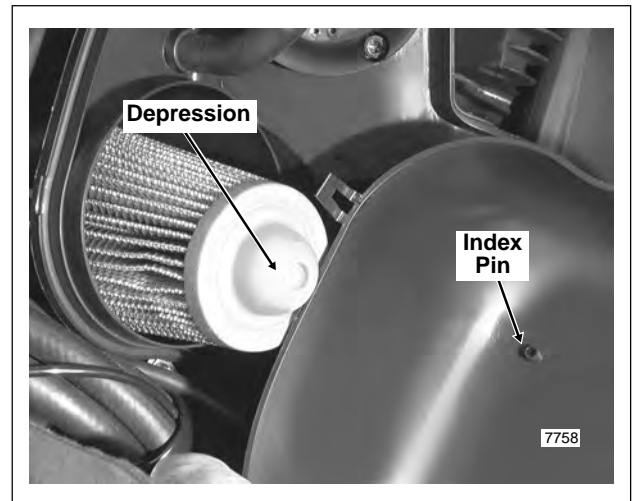

Figure 4-13. Install Air Box Cover

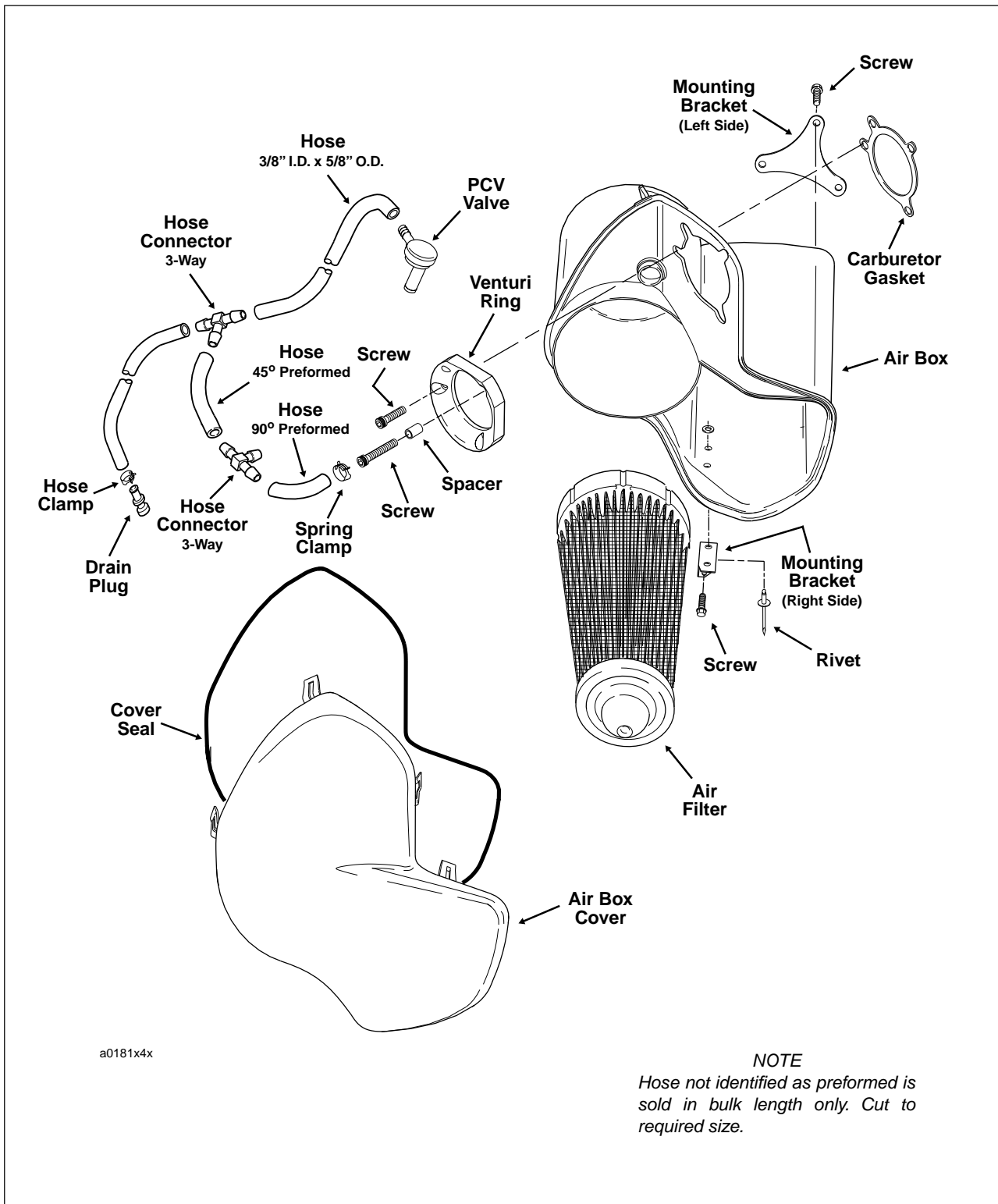

Figure 4-14. Air Cleaner Assembly (Non-California Models)

REMOVAL

1. Remove seat. Depress latch at bottom and pull seat up and back to remove.

WARNING

To protect against shock and accidental start-up of vehicle, disconnect the negative battery cable before proceeding. Inadequate safety precautions could result in death or serious injury.

2. Unthread bolt and remove battery negative cable (black) from battery negative (-) terminal.
3. Moving to left side of vehicle, rotate handle on fuel valve to the fully vertical position to shut the gasoline supply to the carburetor OFF.
4. Remove air cleaner assembly. See 4.3 AIR CLEANER, steps 1-10.
5. Locate 6-place Deutsch connector in front of ignition coil and depress external latch to separate pin and socket halves.
6. Turn slotted screw to loosen band clamp on outboard side of manifold-carburetor coupler. Pull carburetor from coupler.

WARNING

Some gasoline will drain from the fuel inlet hose when disconnected from the carburetor. Thoroughly wipe up any spilt fuel immediately. Dispose of rags in a suitable manner. Gasoline is extremely flammable and highly explosive. Inadequate safety precautions could result in death or serious injury.

7. Using a side cutters, cut clamp and remove fuel inlet hose from fitting at side of carburetor.

NOTE

On California models, pull purge hose from fitting on same side of carburetor.

8. Rotate cable adjusters at handlebar to add slack to idle and throttle cables.

WARNING

As the carburetor is removed, be sure to keep assembly upright as the float bowl contains gasoline. Tilting the carburetor or turning it upside down will cause the gasoline to drain onto surrounding area. Gasoline is extremely flammable and highly explosive. Inadequate safety precautions could result in death or serious injury.

9. Loosen allen head screw to remove cable clamp at top of throttle cable bracket. Using a needle nose pliers, carefully pull idle cable barrel from hole in throttle wheel (farthest from cam stop). Pull throttle cable barrel from remaining hole in throttle wheel. Release idle and throttle cables from guides in throttle cable bracket and remove carburetor from vehicle.
10. Keeping carburetor upright, move to bench area. Without tilting carburetor or turning upside down, remove four

Phillips screws at bottom to remove float bowl from carburetor body. Carefully pour gasoline in float bowl into a suitable container. Loosely install screws to fasten float bowl to carburetor body.

11. If carburetor cleaning is required, proceed as follows:
 - a. Using special TORX bit (Snap-on® TTXR20E), remove two tamper-resistant T20 TORX screws to release throttle position sensor from carburetor housing.
 - b. Remove Phillips screw (with lockwasher) to release stay plate on auto-enrichener from carburetor housing. Pull enrichener from carburetor bore.

INSTALLATION

1. If throttle position sensor and auto-enrichener were removed for carburetor cleaning, proceed as follows:
 - a. Align holes in throttle position sensor with those in carburetor housing. Using special TORX bit (Snap-on® TTXR20E), **loosely** install two tamper-resistant T20 TORX screws.
 - b. Carefully insert auto-enrichener into carburetor bore. Install Phillips screw (with lockwasher) to secure stay plate on enrichener to carburetor housing. Tighten screw to 13-23 **in-lbs** (1.5-2.6 Nm).
2. If loose, tighten four Phillips screws at bottom to secure float bowl to carburetor body.
3. Slide **new** clamp onto free end of fuel inlet hose. Install hose onto fitting at side of carburetor. Crimp clamp using HOSE CLAMP PLIERS (HD-97087-65B).

NOTE

On California models, push purge hose onto fitting on same side of carburetor.

4. Install sleeve on idle cable housing into longer cable guide on throttle cable bracket. Drawing idle cable downward, fit barrel end into hole in throttle wheel (farthest from cam stop). Install sleeve on throttle cable housing into shorter cable guide inserting barrel end into remaining hole in throttle wheel.

5. Verify that cables are seated in channel of throttle wheel, and using cable adjusters at handlebar, tighten cables as necessary to keep barrel ends from dislodging. Verify operation by turning throttle grip and observing cable action.
6. Position cable clamp at top of cable bracket, so that short end is above longer cable guide, long end above shorter cable guide. With clamp capturing sleeves on cable housings, tighten allen head screw to fix position.
7. Install carburetor onto manifold-carburetor coupler. Turn slotted screw to tighten band clamp on outboard side of coupler.
8. Mate pin and socket halves of 6-place Deutsch connector.
9. Adjust throttle cables. See 2.17 THROTTLE CONTROL.
10. Insert bolt through battery negative cable (black) into threaded hole of battery negative (-) terminal. Tighten bolt to 60-96 in-lbs (6.8-10.9 Nm).
11. Adjust throttle position sensor. For instructions, see 4.6 THROTTLE POSITION SENSOR, step 6.
12. Install air cleaner assembly. See 4.3 AIR CLEANER steps 1-12.
13. Position seat on frame backbone, so that tongue at bottom engages slot in frame weldment. Push down on rear of seat until spring-loaded latch fully engages groove of seat pin.

WARNING

Pull up on seat to verify that it is properly secured, front and rear. A loose seat may shift during vehicle operation and startle the rider, possibly causing loss of vehicle control that could result in death or serious injury.

14. Rotate handle of fuel valve to ON and carefully inspect for leaks. Return the valve to the OFF position when finished.
15. Adjust engine idle speed. For instructions, see 1.19 IGNITION TIMING AND IDLE SPEED ADJUSTMENT.

DISASSEMBLY - TOP END

1. Remove gold Phillips screw (with top collar) to free throttle cable bracket from carburetor top. Remove gold Phillips screw (with lockwasher) at side of carburetor to release throttle cable bracket. Set bracket aside.
2. Remove three remaining top screws to release carburetor top from body.
3. Remove vacuum piston spring. Carefully raise diaphragm to remove vacuum piston assembly. Remove spring seat and jet needle from vacuum piston bore. See Figure 4-16.

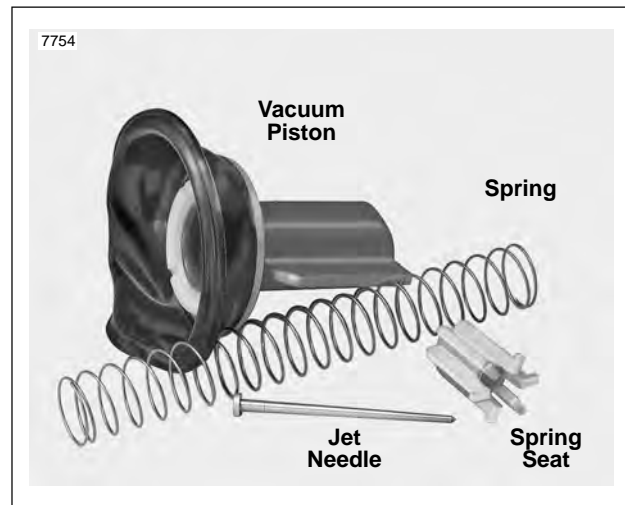

Figure 4-15. Carburetor-Top End

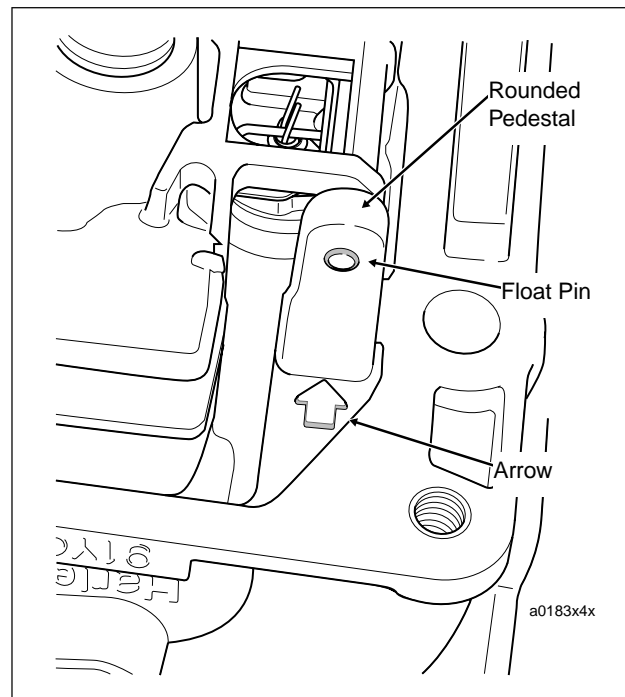

Figure 4-16. Remove Float Pin in Direction of Arrow

DISASSEMBLY - BOTTOM END

1. Turn carburetor upside down and remove four Phillips screws loosely installed at bottom. Remove float bowl from carburetor body.

CAUTION

Tapping the float pin out from the squared pedestal side will result in damage that requires carburetor replacement.

2. Using a small center punch and hammer, carefully tap float pin from holes in pedestals. The rounded pedestal has an interference fit to ensure that the float pin is securely held, so always tap out the pin in the direction of the cast-in arrow (that is, from the interference side). See [Figure 4-16](#).
3. Remove float and fuel valve. Carefully slide clip on fuel valve from tab on float. Remove wireform clip from groove in fuel valve. See upper frame of [Figure 4-18](#).
4. Using slot at top, turn main jet with flat tip screwdriver to unthread from needle jet holder. If necessary, hold hex on needle jet holder with a 5/16 inch wrench to prevent rotation. See [Figure 4-17](#).
5. Using a 5/16 inch wrench, turn hex on needle jet holder to unthread from main jet bore.
6. Turn carburetor right side up to drop out needle jet, which is loose in main jet bore. See middle frame of [Figure 4-18](#).
7. Insert thin bladed flat tip screwdriver into slow jet bore, and using slot at top of slow jet, unthread to remove. See [Figure 4-17](#). and lower frame of [Figure 4-18](#).

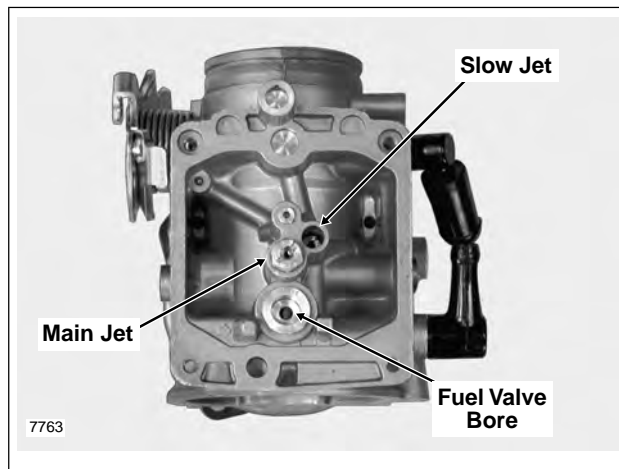

Figure 4-17. Carburetor Housing

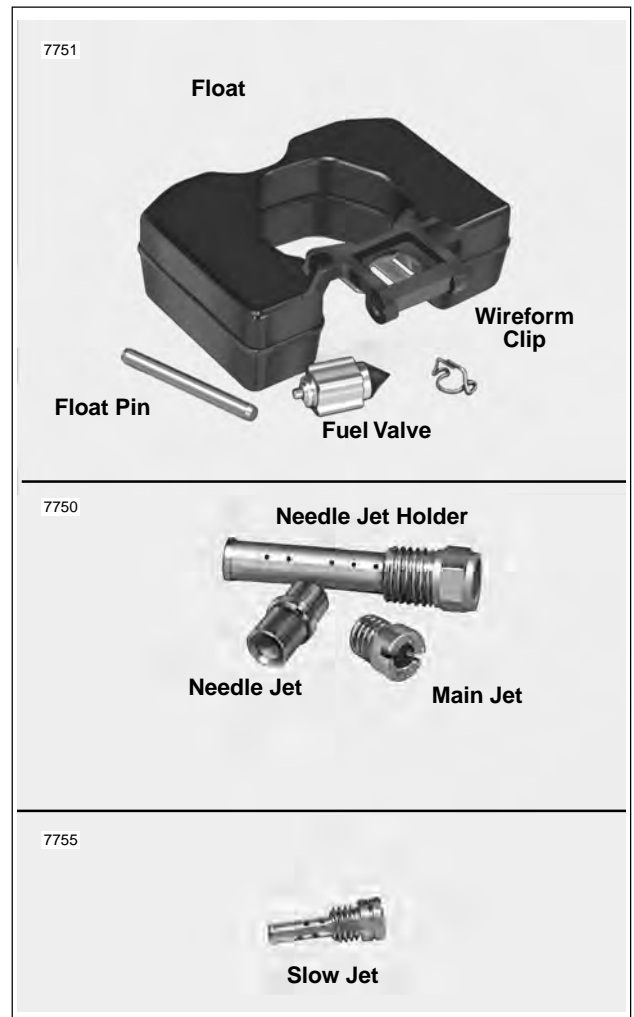

Figure 4-18. Carburetor- Bottom End

CLEANING AND INSPECTION

Carburetor Housing

1. Clean all internal air/fuel passages in carburetor housing with carburetor cleaner. Blow out passages using low pressure compressed air. Proceed as follows:

WARNING

Compressed air can pierce the skin and cause injury. Never use your hand to check for leaks or to determine air flow rates. Wear safety glasses to shield your eyes from flying dirt and debris. Failure to comply could result in death or serious injury.

Slow Speed Circuit

- a. Spray carburetor cleaner into air inlet hole of slow speed circuit. See A of Figure 4-19. While spraying, verify that solution exits slow jet bore at bottom of carburetor housing. See B of Figure 4-19. Placing finger over slow jet bore, verify that solution exits four pin holes just inboard of the throttle plate, as well as the single pin hole outboard of the throttle plate.
- b. Using a tapered, rubber-tipped nozzle on the air hose (to prevent both loss of air pressure and to avoid scratching or nicking the bore), apply low pressure compressed air into air inlet hole to blow carburetor cleaner out of slow jet bore. Placing gloved finger over slow jet bore, blow carburetor cleaner out of pin holes inboard and outboard of throttle plate.

Main Circuit

- a. Plugging main jet hole in carburetor throat, spray carburetor cleaner into air inlet hole of main circuit. See A of Figure 4-19. While spraying, verify that solution exits main jet bore at bottom of carburetor housing. See B of Figure 4-19.
- b. Using a tapered, rubber-tipped nozzle on the air hose (to prevent both loss of air pressure and to avoid scratching or nicking the bore), apply low pressure compressed air into air inlet hole to blow carburetor cleaner out of hole in carburetor throat. Placing gloved finger over hole in carburetor throat, blow carburetor cleaner out of main jet bore at bottom of carburetor housing.

Float Bowl Vent

- a. Spray carburetor cleaner into air inlet hole of float bowl vent. See A of Figure 4-19. While spraying, verify that solution exits two holes in float bowl chamber at bottom of carburetor housing. See B of Figure 4-19.
- b. Using a tapered, rubber-tipped nozzle on the air hose (to prevent both loss of air pressure and to avoid scratching or nicking the bore), apply low pressure compressed air into air inlet hole of float bowl vent to blow carburetor cleaner out of holes in float bowl chamber.

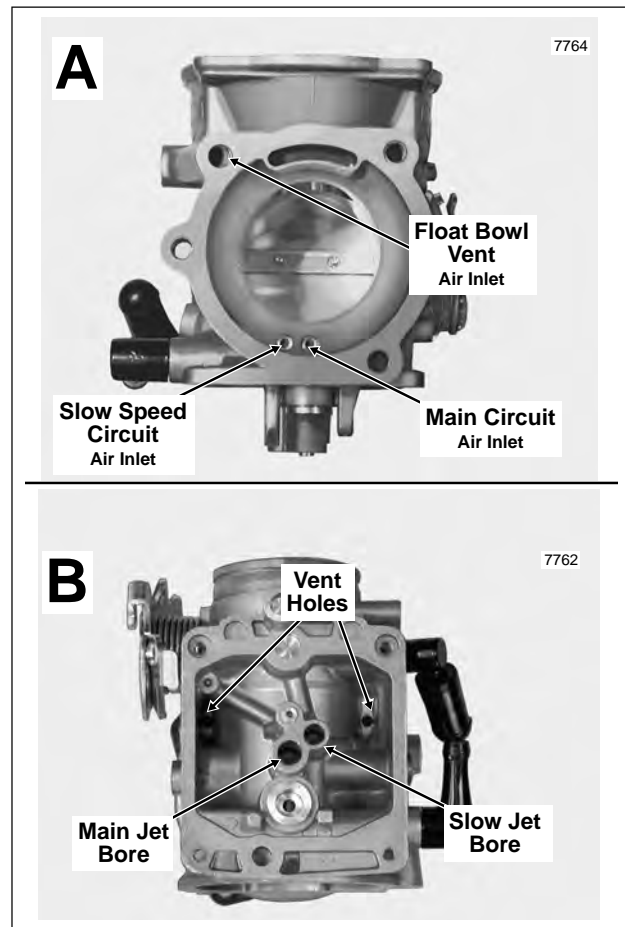

Figure 4-19. Clean Air/Fuel Passages in Carburetor

Top End Components

1. Thoroughly clean all loose parts (except diaphragm) with carburetor cleaner. See Figure 4-15. Blow dry using low pressure compressed air.

WARNING

Compressed air can pierce the skin and cause injury. Never use your hand to check for leaks or to determine air flow rates. Wear safety glasses to shield your eyes from flying dirt and debris. Failure to comply could result in death or serious injury.

2. Inspect parts as follows:
 - a. Hold vacuum piston up to strong light source. Examine diaphragm for pin holes, cuts, tears or pinching. Replace if any damage is found.
 - b. Examine passage at bottom of vacuum piston bore. Verify that passage is clean and open.
 - c. Examine vacuum piston spring for stretching, crimping, distortion or other damage. Inspect spring seat for cracks. Replace parts if necessary.
 - d. Examine slides at sides of vacuum piston to verify that surfaces are clean and smooth. Clean or buff out any rough surfaces.
 - e. Examine tip of jet needle for grooves or scratches. Needle should be completely straight, while surface condition at taper should be smooth and even. Replace needle if necessary.

Bottom End Components

1. Thoroughly clean all loose parts with carburetor cleaner. See [Figure 4-18](#). Blow dry using low pressure compressed air.

WARNING

Compressed air can pierce the skin and cause injury. Never use your hand to check for leaks or to determine air flow rates. Wear safety glasses to shield your eyes from flying dirt and debris. Failure to comply could result in death or serious injury.

2. Inspect parts as follows:
 - a. Inspect O-ring in groove of float bowl for cuts, tears or signs of deterioration. Replace O-ring if distorted or if sealing surface is damaged.
 - b. Inspect float pin for damage or distortion. Replace float pin if corroded, nicked or bent.
 - c. Clean float and inspect for cracks or other damage. Submerge float in a glass of water. Replace float if not water tight.
 - d. Depress pin on fuel valve to verify that it returns to the full-out position. Thoroughly clean valve with carburetor cleaner if pin is dirty or sticks. Inspect rubber cone on valve for dirt, cracks, hardening or wear. Inspect wireform clip for distortion. Replace fuel valve assembly if any of these conditions are found.
 - e. Inspect fuel valve seat in carburetor housing for dirt, damage or corrosion. Replace carburetor if seat damage or corrosion is present.
 - f. Verify cleanliness of slow jet. Be sure that all orifices are clean and open. Replace jet if damaged.

Verify cleanliness of main jet, needle jet holder and needle jet. Verify that orifices in needle jet holder are clean and open. Replace parts if damaged.

ASSEMBLY - TOP END

1. Install vacuum piston into carburetor body. Slides on piston are offset, so piston will fit into slide track groove only one way. If vacuum piston does not fit, rotate assembly 180°.
2. Insert jet needle into vacuum piston bore, so that it enters center hole at bottom. In the installed position, head of needle contacts boss at bottom of vacuum piston bore, while length of shaft resides in main jet bore.
3. With the legged side down, slide spring seat over top of needle in vacuum piston bore. Slide spring over spring seat.
4. Verify that lip on edge of diaphragm is seated in groove of carburetor flange.

NOTE

Diaphragm expands when in contact with fuel. If diaphragm is difficult to seat in groove because of this condition, allow diaphragm to dry before attempting to install.

5. Fit free end of spring over boss on inboard side of carburetor top, and keeping spring straight, align holes in top with those in flange.
6. Holding top to flange, check for proper diaphragm seal by pushing up on vacuum piston (from intake side) and releasing. If diaphragm is sealed correctly, very slight resistance should be felt when pushing up, and piston should be slow to extend. If piston movement is restricted, spring is cocked. Lift up on top and then lower carefully keeping spring coils straight.
7. Install three black top screws in holes furthest from throttle wheel. Alternately tighten screws until snug.
8. Slide gold top collar into remaining hole in carburetor top. With end of idle screw resting on top of throttle cam stop, align holes in throttle cable bracket with those in carburetor body and top cover. To prevent bending bracket or throttle cam, first install gold Phillips screw (with lock-washer) at side of carburetor. At carburetor top, install remaining Phillips screw.

ASSEMBLY - BOTTOM END

1. Insert slow jet into slow jet bore. See [Figure 4-18](#). Insert thin bladed flat tip screwdriver into bore, and using slot at top of slow jet, tighten until snug.
2. Place needle jet into main jet bore. See [Figure 4-18](#). Be sure end with chamfered edge and larger ID goes in first.
3. Insert needle jet holder into main jet bore, and using a 5/16 inch wrench, turn hex until snug.
4. Thread main jet into needle jet holder. Using slot at top of main jet, tighten with flat tip screwdriver until snug.
5. Install wireform clip into groove on pin side of fuel valve, if removed. Using wireform clip, carefully hang fuel valve onto tab of float, so that tip of rubber cone hangs flush with top of float (the top being the side opposite the pivot arm).
6. Place float into cavity of carburetor inserting fuel valve into bore between pedestals. See [Figure 4-17](#).

CAUTION

Tapping the float pin in from the rounded pedestal side will result in damage that requires carburetor replacement.

7. Insert float pin through squared pedestal and pivot arm of float into rounded pedestal. Since the rounded pedestal has an interference fit to ensure that the float pin is securely held, always install pin from the loose side (in the direction opposite the cast-in arrow). Using a small center punch and hammer, carefully tap float pin until ends are flush with outboard sides of pedestals.
8. Perform float level check as follows:
 - a. Place carburetor on a clean flat surface with the intake manifold side down. See A of [Figure 4-20](#).
 - b. Tilt the carburetor 15° to 20° in a counter-clockwise direction until float comes to rest. See B of [Figure 4-20](#).

NOTE

The measurements will be incorrect if the carburetor is tilted less than 15° or more than 20°.

- c. Using a dial vernier caliper or dial caliper depth gauge, measure the distance from the face of the carburetor flange to the outboard edge of the float. Be careful not to push on float while measuring.
 - d. If the measurement is between 0.413 inch and 0.453 inch (10.49 - 11.51 mm), then the float level is within specification. Proceed to step 9.
 - e. If the float level is not within specification, remove the float, and referencing the table below, carefully bend the tab slightly to adjust the float level. For example, to increase the float measurement, bend the tab toward the carburetor body. This will have the affect of decreasing the amount of gas in the float bowl after assembly.
 - f. Install float and check float level again. Repeat procedure as necessary until float level is within specification.
9. Install new O-ring into groove of float bowl, if removed. Be sure to thoroughly clean groove before O-ring installation.

10. Install four Phillips screws to secure float bowl at bottom of carburetor body. Tighten screws until snug.

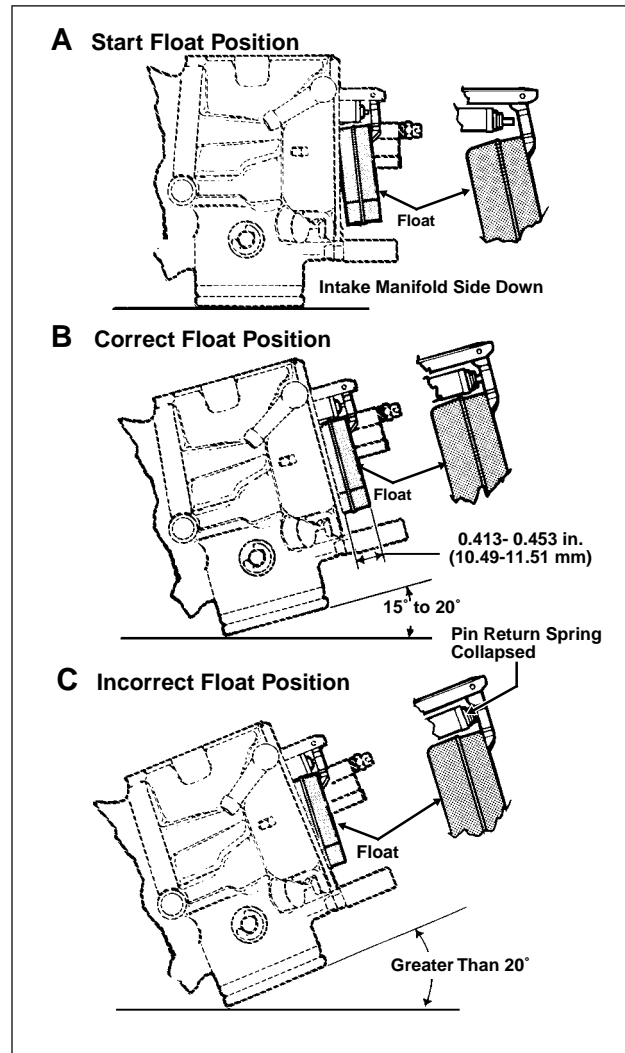

Figure 4-20. Float Check and Adjustment

Float Level Tab		
Float Measurement	Bend Tab	Amount of Gas in Float Bowl
To Increase	<u>Toward</u> Carburetor Body	Decreased
To Decrease	<u>Away From</u> Carburetor Body	Increased

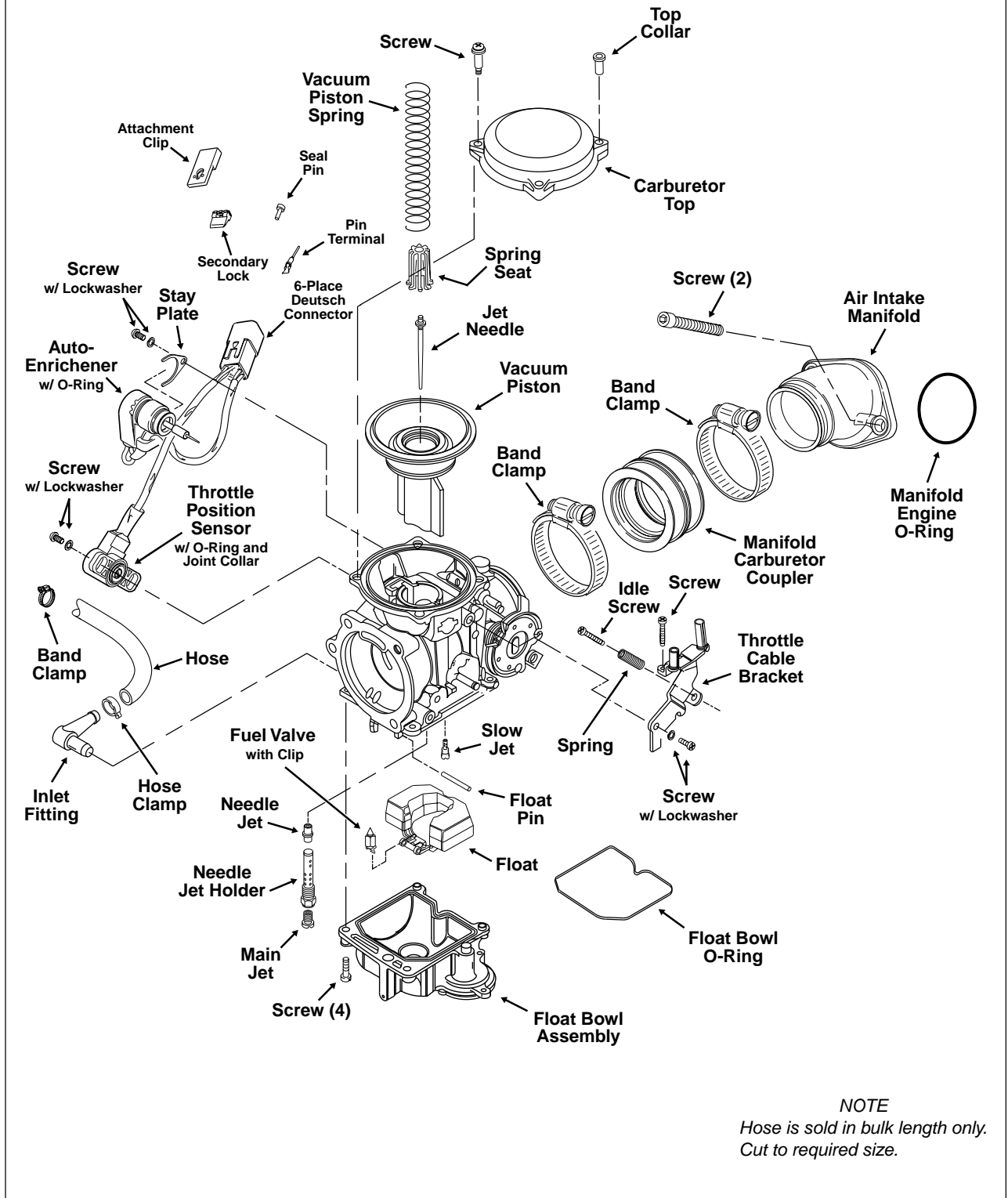

Figure 4-21. Carburetor Assembly

REMOVAL

NOTE

For electrical diagnostics and troubleshooting, please refer to 7.7 AUTO ENRICHENER.

1. Remove seat. Depress latch at bottom and pull seat up and back to remove.

WARNING

To protect against shock and accidental start-up of vehicle, disconnect the negative battery cable before proceeding. Inadequate safety precautions could result in death or serious injury.

2. Unthread bolt and remove battery negative cable (black) from battery negative (-) terminal.
3. Release five latches around perimeter of air box cover.
4. Remove single Phillips screw at bottom of air box cover (7 o'clock position).
5. Pull cover from air box.
6. Remove hex screw at bottom of air box (6 o'clock position) to release bracket from crankcase hole.
7. Moving to left side of vehicle, remove top two flange bolts from triangular shaped bracket fastened to crankcase. Do not remove bottom bolt to crankcase.

CAUTION

Do not take bolt in and out of the crankcase unless necessary. Since the potential for stripping always exists during removal and installation, leave the bolt intact to avoid possible damage to the crankcase.

8. Returning to the right side of the vehicle, turn slotted screw to loosen band clamp on outboard side of manifold-carburetor coupler. Pull carburetor from coupler.
9. Carefully pull air box out of opening. When partially removed, detach PCV outlet hose from middle fitting on 3-way connector.
10. Locate 6-place Deutsch connector in front of ignition coil and depress external latch to separate pin and socket halves. Remove pin terminals from chambers 1 and 2.

NOTE

For instructions on properly removing wire terminals, see Appendix B.

11. Remove Phillips screw (with lockwasher) to release stay plate on auto-enrichener from carburetor housing. Pull enrichener from carburetor bore.

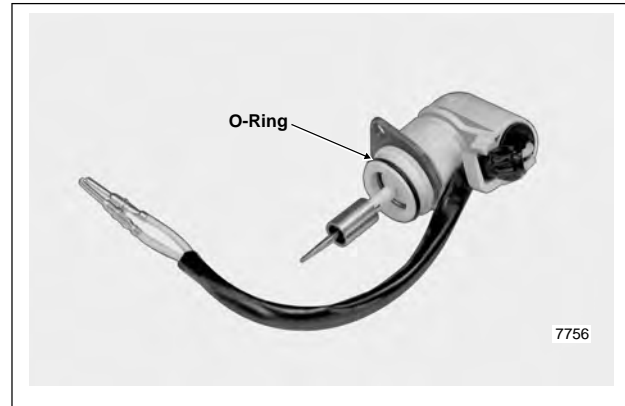
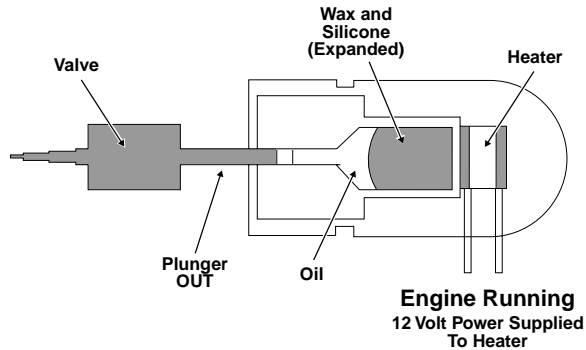
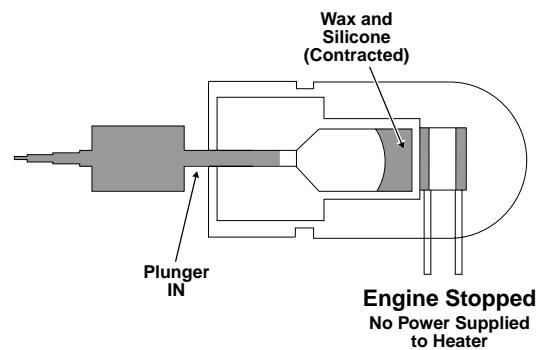

Figure 4-22. Auto-Enrichener

A Heater is Activated When Vehicle Started. Silicone Expands As It Warms. Expansion Begins to Push Plunger Out.



C Heater is Deactivated When Vehicle Shut Off. Silicone Contracts As It Cools. Contraction Begins to Pull Plunger In.



B As Wax Warms, Stroke of Plunger Gradually Increases to CLOSE Valve. NO Extra Fuel and Air are Provided.

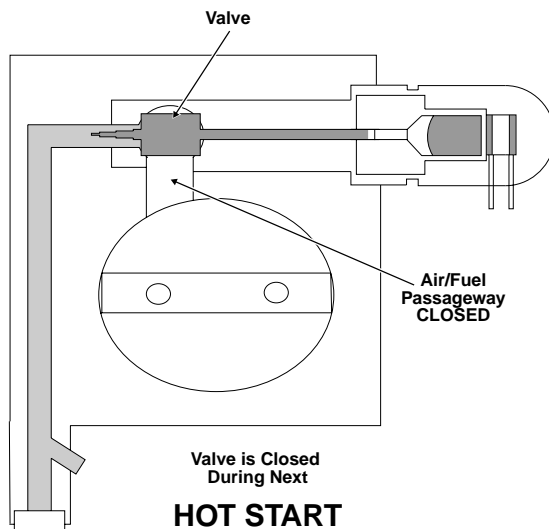

D As Wax Cools, Stroke of Plunger Gradually Decreases to OPEN Valve. Extra Fuel and Air are Provided.

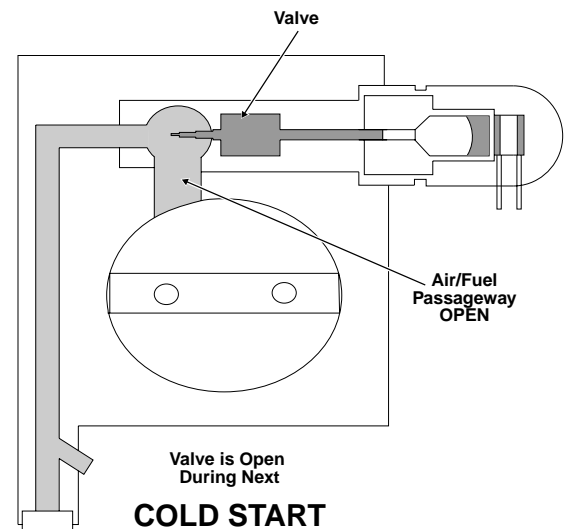

Auto-Enrichener Operation

The auto-enrichener is one of the first idle devices to be operated by a wax element. A silicone liquid is enclosed in the wax and its volume increases or decreases with changes in temperature. Based upon whether the wax element is being cooled or heated, the enrichener valve automatically opens or closes.

During a cold start, the enrichener valve is open. Whether the valve is fully or partially open is dependent upon the ambient temperature. The extra fuel and air supplied to the engine causes it to idle fast.

Starting the vehicle also supplies 12 volts from the motorcycle power supply to the heater. As the heater warms the wax element, the silicone gradually expands to push the plunger out, eventually closing the enrichener valve at the end of its stroke. When the enrichener valve is closed (about 2-5* minutes from the time the engine is first started cold), the passageway that supplies the extra fuel and air is blocked and the fast idle stops. See A and B above.

When the ignition is shut off, the power to the heater is cut. Deactivation of the heater causes the wax element to begin to cool. During some hot (warm) starts, the wax element may have cooled quicker than the engine, which can result in a fast idle period of short duration.

When the wax element has cooled sufficiently, the silicone gradually contracts to pull the plunger in. At the end of its return

INSTALLATION

1. Obtain **new** auto-enrichener assembly. If old enrichener is used, inspect O-ring for cuts, tears or signs of deterioration. Replace O-ring if necessary. See Figure 4-22.
2. Carefully insert auto-enrichener into carburetor bore. Install Phillips screw (with lockwasher) to secure stay plate on enrichener to carburetor housing. Tighten screw to 13-23 **in-lbs** (1.5-2.6 Nm).
3. Locate 6-place Deutsch connector and install pin terminals in chambers 1 and 2. Mate pin and socket halves of connector.

NOTE

For instructions on properly installing wire terminals, see Appendix B.

4. Standing on the right side of the vehicle, start air box into opening. When partially installed, push PCV outlet hose onto middle fitting of 3-way connector, and loosely install carburetor onto manifold-carburetor coupler.
5. Moving to opposite side of vehicle, apply a small dab of Loctite Low Strength Threadlocker 222 (Purple) to threads of two flange bolts. Slide bolts through top two holes of triangular bracket and install into left side of air box. Alternately tighten screws to 3-5 ft-lbs (4.1-6.8 Nm).
6. Returning to the right side of the vehicle, fix position of carburetor on manifold-carburetor coupler. Turn slotted screw to tighten band clamp on outboard side of coupler.
7. Apply one drop of Loctite High Strength Threadlocker 262 (red) to threads of hex screw. Install screw at bottom of air box (6 o'clock position) to secure air box bracket to crankcase hole. Tighten screw to 10-12 ft-lbs (13.6-16.3 Nm).
8. Taking note of index pin on inboard side of cover and small depression at tip of cone, position cover onto air box so that pin engages depression.
9. Lock five latches around perimeter of air box cover.
10. Install Phillips screw at bottom of air box cover (7 o'clock position) to secure cover to air box. Tighten screw to 4-6 **in-lbs** (0.5-0.7 Nm).
11. Insert bolt through battery negative cable (black) into threaded hole of battery negative (-) terminal. Tighten bolt to 60-96 **in-lbs** (6.8-10.9 Nm).
12. Position seat on frame backbone, so that tongue at bottom engages slot in frame weldment. Push down on rear of seat until spring-loaded latch fully engages groove of seat pin.

WARNING

Pull up on seat to verify that it is properly secured, front and rear. A loose seat may shift during vehicle operation and startle the rider, possibly causing loss of vehicle control that could result in death or serious injury.

REMOVAL

NOTE

For electrical diagnostics and troubleshooting, please refer to 7.4 THROTTLE POSITION SENSOR (TP Sensor).

1. Remove seat. Depress latch at bottom and pull seat up and back to remove.

WARNING

To protect against shock and accidental start-up of vehicle, disconnect the negative battery cable before proceeding. Inadequate safety precautions could result in death or serious injury.

2. Unthread bolt and remove battery negative cable (black) from battery negative (-) terminal.
3. Release five latches around perimeter of air box cover.
4. Remove single Phillips screw at bottom of air box cover (7 o'clock position).
5. Pull cover from air box.
6. Remove hex screw at bottom of air box (6 o'clock position) to release bracket from crankcase hole.
7. Moving to left side of vehicle, remove top two flange bolts from triangular shaped bracket fastened to crankcase. Do not remove bottom bolt to crankcase.

CAUTION

Do not take bolt in and out of the crankcase unless necessary. Since the potential for stripping always exists during removal and installation, leave the bolt intact to avoid possible damage to the crankcase.

8. Returning to the right side of the vehicle, turn slotted screw to loosen band clamp on outboard side of manifold-carburetor coupler. Pull carburetor from coupler.
9. Carefully pull air box out of opening. When partially removed, detach PCV outlet hose from middle fitting on 3-way connector.
10. Locate 6-place Deutsch connector in front of ignition coil and depress external latch to separate pin and socket halves. Remove pin terminals from chambers 3 through 5.

NOTE

For instructions on properly removing wire terminals, see SECTION 7, ELECTRICAL, DEUTSCH ELECTRICAL CONNECTORS.

11. Using special TORX bit (Snap-on® TTXR20E), remove two tamper-resistant T20 TORX screws to release throttle position sensor from carburetor. Pull sensor from carburetor bore.

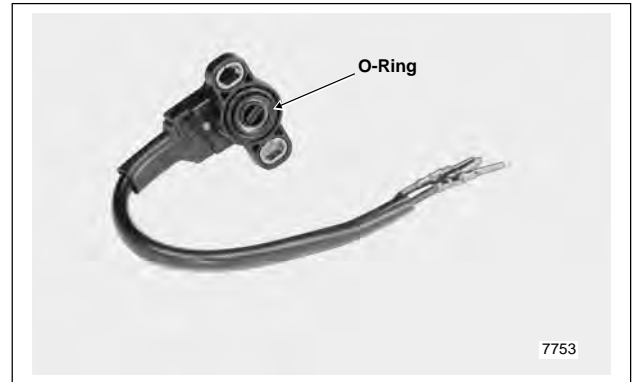

Figure 4-24. Throttle Position Sensor

INSTALLATION

1. Obtain **new** throttle position sensor. If old sensor is used, inspect O-ring for cuts, tears or signs of deterioration. Replace O-ring if necessary. See [Figure 4-24](#).
2. Align holes in throttle position sensor with those in carburetor housing. Using special TORX bit (Snap-on® TTXR20E), **loosely** install two tamper-resistant T20 TORX screws.

NOTE

The tamper-resistant screws are not to be tightened until the throttle position sensor has been properly adjusted. See the instructions under step 6 for details.

3. Locate 6-place Deutsch connector and install pin terminals in chambers 3 through 5. Mate pin and socket halves of connector.

Throttle Position Sensor Connector		
Chamber Number	Wire Color	Function
3	Light Blue	Output
4	Yellow	Input
5	Black	Ground

NOTE

For instructions on properly installing wire terminals, see [Appendix B](#).

4. Insert bolt through battery negative cable (black) into threaded hole of battery negative (-) terminal. Tighten bolt to 60-96 **in-lbs** (6.8-10.9 Nm).
5. Standing on the right side of the vehicle, start air box into opening. When partially installed, push PCV outlet hose onto middle fitting of 3-way connector, and loosely install carburetor onto manifold-carburetor coupler.
6. Adjust throttle position sensor as follows:
 - a. Back off idle adjustment screw so throttle plate is fully closed.
 - b. Completely open and close the throttle by rotating the throttle control through its full range of motion.
 - c. Using special TORX bit (Snap-on® TTXR20E), loosen the two tamper-resistant T20 TORX screws just enough to allow sensor to rotate.
 - d. Install 6-place Harness adaptor (HD-42962) and Breakout Box between ignition module/cam position connectors [10A] and [10B].
 - e. Turn ignition switch to ON. Using a multimeter measure voltage between pin 2 (V/W) and pin 6 (BK).
 - f. Adjust (rotate) TPS until voltage reading is 0.5V +/- 0.02V.
 - g. Completely open and close the throttle by rotating the throttle control through its full range of motion. Verify that voltage reading increases smoothly as throttle is opened. Voltage at Wide Open Throttle (WOT) should not exceed 3.7V.
 - h. Tighten screws to 13-23 **in-lbs** (1.5-2.6 Nm) and verify that voltage output reading has not changed.
7. Moving to opposite side of vehicle, apply a small dab of Loctite Low Strength Threadlocker 222 (Purple) to

threads of two flange bolts. Slide bolts through top two holes of triangular bracket and install into left side of air box. Alternately tighten screws to 3-5 ft-lbs (4.1-6.8 Nm).

8. Returning to the right side of the vehicle, fix position of carburetor on manifold-carburetor coupler. Turn slotted screw to tighten band clamp on outboard side of coupler.
9. Apply one drop of Loctite High Strength Threadlocker 262 (red) to threads of hex screw. Install screw at bottom of air box (6 o'clock position) to secure air box bracket to crankcase hole. Tighten screw to 10-12 ft-lbs (13.6-16.3 Nm).
10. Taking note of index pin on inboard side of cover and small depression at tip of cone, position cover onto air box so that pin engages depression.
11. Lock five latches around perimeter of air box cover.
12. Install Phillips screw at bottom of air box cover (7 o'clock position) to secure cover to air box. Tighten screw to 4-6 **in-lbs** (0.5-0.7 Nm).
13. Position seat on frame backbone, so that tongue at bottom engages slot in frame weldment. Push down on rear of seat until spring-loaded latch fully engages groove of seat pin.

WARNING

Pull up on seat to verify that it is properly secured, front and rear. A loose seat may shift during vehicle operation and startle the rider, possibly causing loss of vehicle control that could result in death or serious injury.

14. Adjust engine idle speed, as follows:

NOTE

Be sure the engine is warmed up to normal operating temperature **BEFORE** adjusting engine idle speed.

- a. With the engine at normal operating temperature (auto-enrichener valve closed), adjust the throttle stop screw so the engine idles at 1200 rpm.

NOTE

To measure engine rpm, use a hand held inductive tachometer (Snap-on® ONO-SE-1100) to pick up the signal off the spark plug cable.

GENERAL

Buell motorcycles sold in the state of California are equipped with an evaporative (EVAP) emissions control system. In conformance with California Air Resource Board (CARB) regulations, the EVAP system prevents both fuel and crankcase vapors from escaping into the atmosphere. See [Figure 4-25](#).

The EVAP system functions as follows:

- The fuel vapor **vent tube** connected to the fitting at the front of the fuel cap flange allows fuel vapors in the fuel tank to be vented through the rollover valve to the charcoal canister. If the vehicle is tipped, the rollover valve also prevents the loss of gasoline through the vent tube.
- When the engine is running, negative pressure (vacuum) created at the carburetor venturi draws the fuel vapors stored in the charcoal canister through the **purge hose** to the carburetor where they are burned as part of the normal combustion process.
- Fuel vapors emanating from the carburetor throat are drawn to the charcoal canister through a fitting on the **PCV outlet hose**. A preformed hose on one end of the

fitting is fixed to an allen head screw on the venturi ring for positive location.

- Crankcase vapors passing through the PCV valve follow the fuel vapors to the charcoal canister via a 3-way fitting plumbed into the PCV outlet hose. The fuel and crankcase vapors, after passing through the charcoal canister, travel through the purge hose to the carburetor, and like the vapors from the fuel tank, are burned during combustion.

WARNING

Verify that the vent tubes and hoses do not contact hot exhaust or engine parts. Tubes contain flammable vapors that can be ignited if damaged, possibly causing fire or explosion, which could result in death or serious injury.

NOTE

The EVAP system has been designed to operate with a minimum of maintenance. Check that all hoses are correctly routed and properly connected. Also, verify that the hoses are not pinched or kinked.

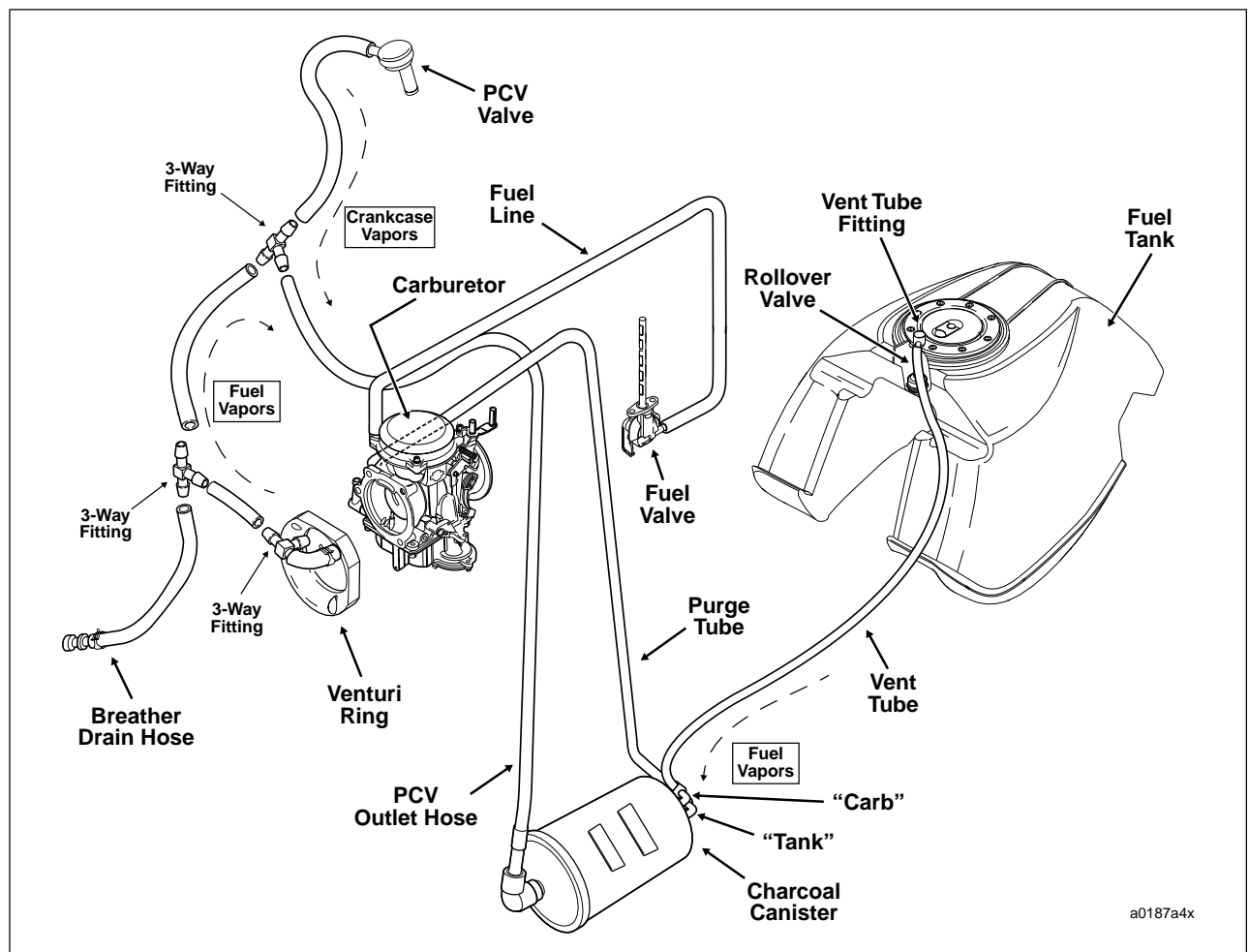

Figure 4-25. California Evaporative Emissions Control System Schematic

CHARCOAL CANISTER

NOTE

On 49 State models, the charcoal canister is absent and the fuel vapor vent tube is vented to the atmosphere.

Removal

1. Remove seat. Depress latch at bottom and pull seat up and back to remove.

WARNING

Always disconnect the negative battery cable first. If the positive cable should contact ground with the negative cable installed, the resulting sparks may cause a battery explosion which could result in death or serious injury.

2. Unthread bolt and remove battery negative cable (black) from battery negative (-) terminal.
3. Standing on left side of vehicle, pull two vent tubes from fittings at the back of the charcoal canister. For correct assembly, mark tubes to correlate with stamps on canister. Mark one tube "CARB" and the other "TANK."
4. Pull PCV outlet hose (connection from carburetor throat and PCV valve) from fitting at front of charcoal canister.
5. Slide charcoal canister rearward until backside of tongue at top of canister just contacts two legs on bracket. Holding canister in position, use the tip of a large screwdriver to push up on outboard leg until it comes down to rest on

top of tongue. See Figure 4-27. Repeat procedure to release leg on inboard side of bracket.

6. Slide charcoal canister toward rear of vehicle until tongue at top of canister is completely free of grooves in bracket.

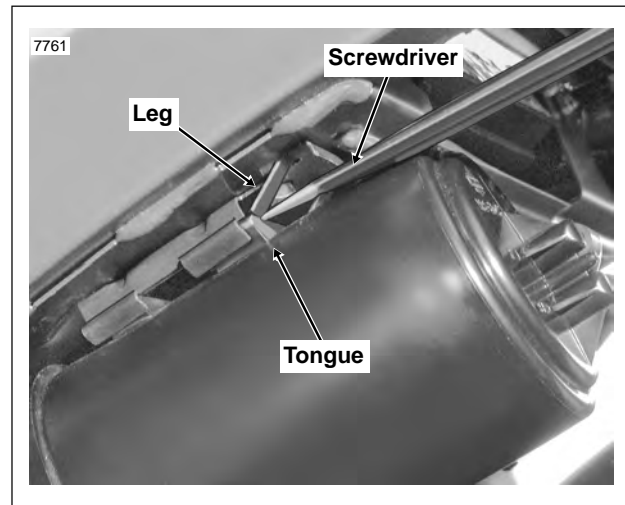

Figure 4-26. Push Up On Legs Of Bracket to Release Charcoal Canister

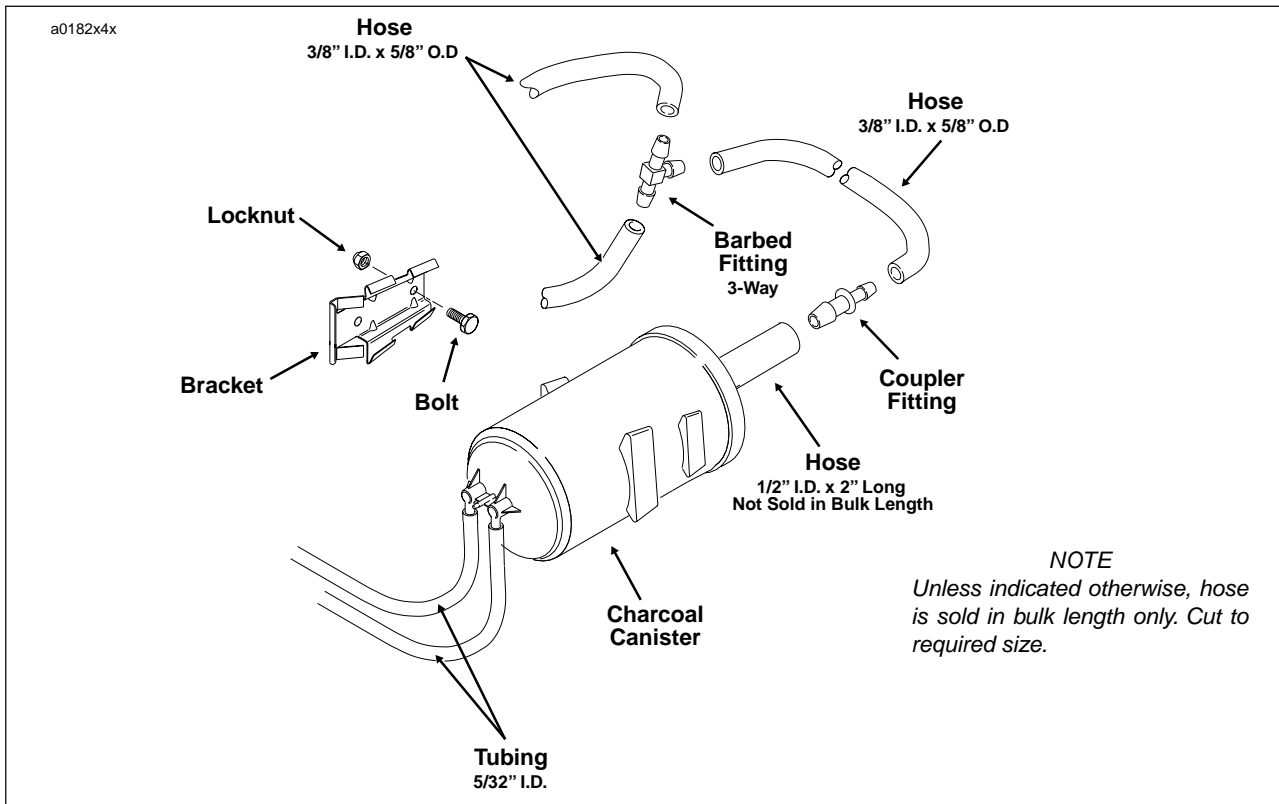

Figure 4-27. Charcoal Canister Assembly

Installation

1. With the vent tube fittings at the rear and pointing inboard, start tongue at top charcoal canister into grooves of bracket.
2. Push charcoal canister toward front of vehicle until legs on bracket snap down to engage back of tongue.
3. Attach vent tubes to fittings at back of charcoal canister. For correct assembly, tubes should have been marked to correlate with stamps on canister, that is, either "CARB" or "TANK."
4. Attach PCV outlet hose (connection from carburetor throat and PCV valve) to fitting at front of charcoal canister.

⚠ WARNING

Verify that the vent tubes and hoses do not contact hot exhaust or engine parts. Tubes contain flammable vapors that can be ignited if damaged, possibly causing fire or explosion, which could result in death or serious injury.

5. Recheck vent tube routing to be sure that hoses are not pinched or kinked.
6. Insert bolt through battery negative cable (black) into threaded hole of battery negative (-) terminal. Tighten bolt to 60-96 **in-lbs** (6.8-10.9 Nm).
7. Position seat on frame backbone, so that tongue at bottom engages slot in frame weldment. Push down on rear of seat until spring-loaded latch fully engages groove of seat pin.

⚠ WARNING

Pull up on seat to verify that it is properly secured, front and rear. A loose seat may shift during vehicle operation and startle the rider, possibly causing loss of vehicle control that could result in death or serious injury.

ROLLOVER VALVE

See 4.2 FUEL TANK COVER/FUEL TANK.

HOSE ROUTING

Crankcase Breather/Drain/PCV Outlet Hose

Crankcase Breather Hose: The crankcase breather hose runs forward from the PCV valve at the top of the rocker cover through a cable strap loosely installed in two lateral holes in the front engine mounting bracket (just rear of the steering head). After passing through the cable strap, the hose loops rearward following the bottom left side of the frame backbone, where it is captured in yet another cable strap loosely installed around the middle of the backbone (the second of three equally spaced cable straps moving front to rear). Continuing rearward, the hose passes toward the right side of the vehicle just in front of the ignition coil where it mates with a 3-way connector positioned inboard of the carburetor.

First 3-Way Connector: The 3-way connector inboard of the carburetor splits the path of the hose into two directions. The center barb, pointed at the left side of the vehicle, is attached to the hose routed to the charcoal canister, while the end barb is connected to a short hose that jumps to a second 3-

way connector located inboard of the air box.

Charcoal Canister Hose: The hose to the charcoal canister is routed from the center barb on the first 3-way connector back to the left side of the vehicle just behind the ignition coil, and then downward following the rearward arc created by the rounded top of the air box. The hose then runs over the top rear corner of the inner primary housing and enters the loop formed by the hose connected to the oil drain/return fitting at the left side of the frame backbone. Passing through this loop, the hose enters an opening at the front of the passenger foot peg support where it is then connected to the fitting at the front of the charcoal canister.

Second Three-Way Connector: The second 3-way connector inboard of the air box splits the path of the hose once again. The center barb, pointed at the right side of the vehicle, is connected to a hose that runs through a hole in the air box, where it mates with a third and final 3-way connector. The hose on the end barb of the third 3-way connector is clamped to the gold allen head screw on the venturi ring (so that the center barb is positioned at the carburetor throat).

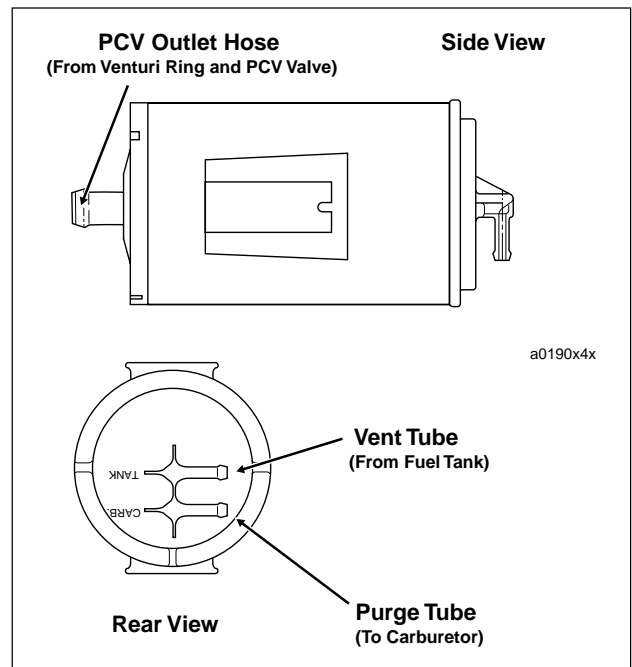

Figure 4-28. Charcoal Canister

Crankcase Breather Drain Hose: The end barb of the second 3-way connector routes the hose to the right side of the vehicle between the top of the air box and the bottom of the frame backbone, where it runs rearward following the bottom right side of the frame backbone. The hose then cuts back to the left side of the vehicle through the opening formed by the frame and the rear of the air box (just above the electric starter). After returning to the left side, the hose passes through the loop formed by the hose connected to the oil drain/return fitting. The hose enters an opening at the front of the passenger foot peg support where it is then clamped along the inboard side above the oil drain hose.

Vent Tube

The vent tube, which is cable strapped to the nozzle of the vent tube fitting at the front of the fuel cap flange, runs downward on the left side of the fuel tank and turns rearward pass-

ing through a cable strap loosely installed around the front of the frame backbone (the first of three equally spaced cable straps moving front to rear). From this point, the vent tube follows the main harness through a large hole in the front engine mounting bracket (just rear of the two lateral holes described earlier). Continuing rearward, the tube follows the bottom left side of the frame backbone running inboard of the crankcase breather hose. Moving outboard of the breather

hose just in front of the ignition coil, the tube follows the ignition module conduit down the left side of the frame backbone and passes through the loop formed by the hose connected to the oil drain/return fitting. The tube enters an opening at the front of the passenger foot peg support where it is runs rearward to connect to the upper fitting at the back of the charcoal canister. One cable strap is used to connect the "carb" and "tank" vent tubes together at the back of the canister, while another secures both tubes to the PCV outlet hose

at the front of the canister.

NOTE

On non-California models, the end of the "tank" vent tube gets routed through the slot at the front of the tail section and then into the cavity on the inboard side of the battery box (alongside the transmission vent hose), while the "carb" vent tube (purge tube) is absent.

Purge Tube

The purge tube is connected to a fitting on the inboard side of the carburetor, where it passes to the right side of the vehicle just behind the ignition coil. From this point, the tube runs rearward following the same path as the hose to charcoal canister (front fitting), except that it is connected to the lower fitting at the back of the canister.

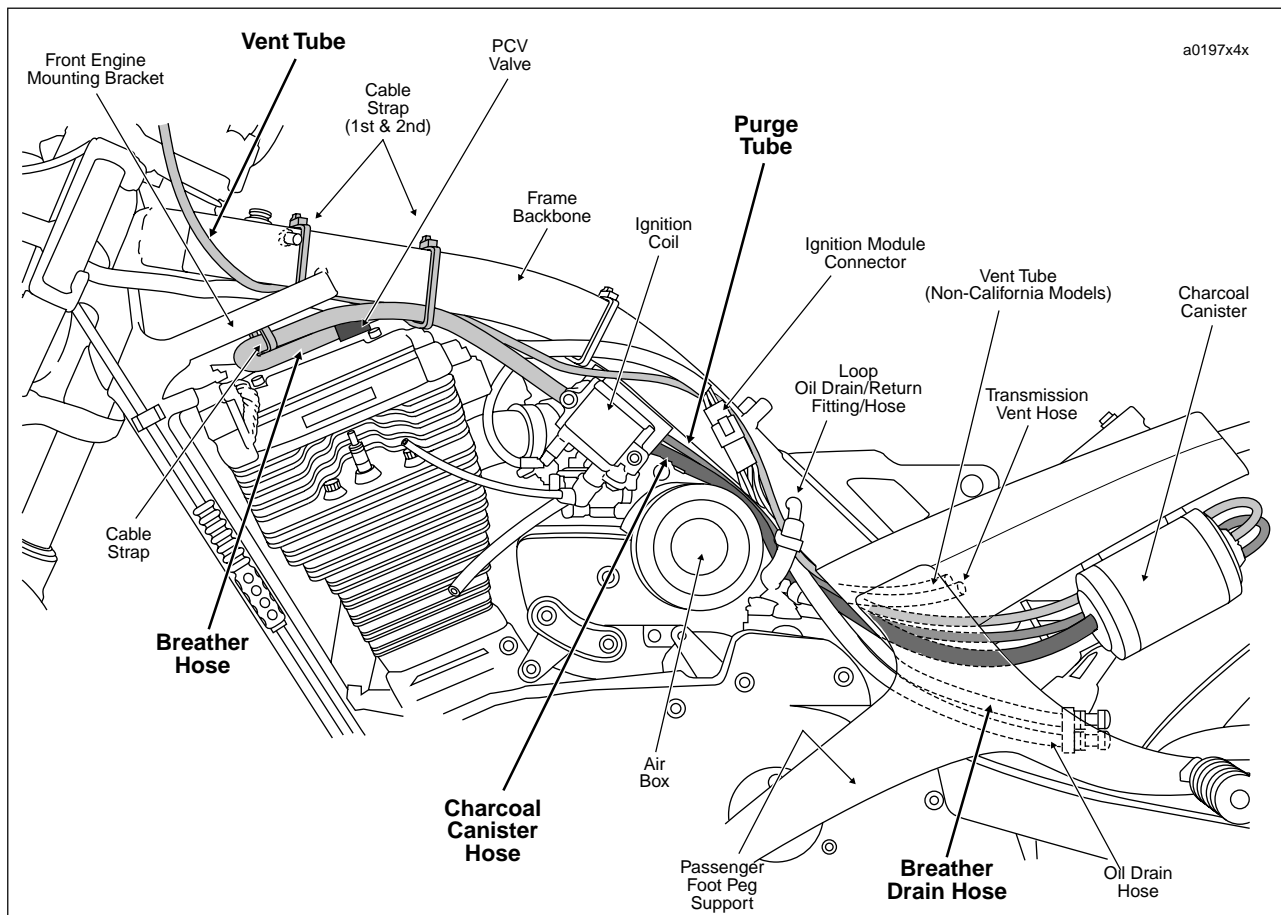

Figure 4-29. Hose Routing (Left Side View)

SUBJECT	PAGE NO.
5.1 Specifications	5-1
5.2 Electric Starter System	5-2
5.4 Starter Activation Circuits	5-7
5.5 Diagnostics/Troubleshooting	5-8
5.6 Starter System Testing	5-10
5.7 Starter	5-11
5.8 Starter Solenoid	5-19

STARTER	
Free Speed	3000 RPM (min.) @ 11.5 V
Free Current	90 amp (max.) @ 11.5 V
Stall Current	400 amp (max.) @ 2.4 V
Stall Torque	8.1 ft-lbs (11.0 Nm) (min.) @ 2.4 V

SERVICE WEAR LIMITS	IN.	MM
Brush Length minimum	0.433	11.0
Commutator Diameter minimum	1.141	28.981

TORQUE VALUES

ITEM	TORQUE		NOTES
Starter Battery Positive Cable Nut	60-85 in-lbs	6.8-9.6 Nm	Metric, page 5-20
Starter Mounting Bolts	13-20 ft-lbs	17.6-27.1 Nm	Page 5-20
Battery Terminal Bolts	60-96 in-lbs	7-11 Nm	Page 5-20

GENERAL

The starter is made up of an armature, field winding assembly, solenoid, drive assembly, idler gear and drive housing.

The starter motor torque is increased through gear reduction. The gear reduction consists of the drive pinion on the armature, an idler gear and a clutch gear in the drive housing. The idler gear is supported by rollers. The clutch gear is part of the overrunning clutch/drive assembly.

The overrunning clutch is the part which engages and drives the clutch ring gear. It also prevents the starter from overrunning. The field windings are connected in series with the armature through brushes and commutator segments.

Wiring Diagrams

For additional information concerning the starting system circuit, see the wiring diagram at the end of Section 7, ELECTRICAL.

Starter Relay

The starter relay is not repairable. Replace the unit if it fails.

Starter Interlock

See 7.11 STARTER/IGNITION INTERLOCK for operation and troubleshooting information.

OPERATION

NOTE

The clutch lever must be pulled in for the starting system to function.

See Figure 5-1. When the starter switch is pushed, the starter relay is activated and battery current flows into the pull-in winding (10) and the hold-in winding (11), to ground.

The magnetic forces of the pull-in and hold-in windings in the solenoid push the plunger (7) causing it to shift to the left. This action engages the pinion gear (1) with the clutch ring gear (13). At the same time, the main solenoid contacts (8) are closed, so battery current flows directly through the field windings (3) to the armature (4) and to ground. Simultaneously, the pull-in winding (10) is shorted.

The current continues flowing through the hold-in winding (11) keeping the main solenoid contacts (8) closed. At this point, the starter begins to crank the engine.

After the engine has started, the pinion gear (1) turns freely on the pinion shaft through the action of the overrunning clutch (12). The overrunning clutch prevents the clutch ring gear (13) (which is now rotating under power from the engine) from turning the armature (4) too fast.

When the starter switch is released, the current of the hold-in winding (11) is fed through the main solenoid contacts (8) and the direction of the current in the pull-in winding (10) is reversed. The solenoid plunger (7) is returned to its original position by the return spring, which causes the pinion gear (1) to disengage from the clutch ring gear (13).

a0191x5x

- 1. Pinion Gear
- 2. Idler Gear
- 3. Field Winding
- 4. Armature
- 5. Brush
- 6. Ball Bearing
- 7. Solenoid Plunger
- 8. Main Solenoid Contacts
- 9. Battery
- 10. Pull-in Winding
- 11. Hold-in Winding
- 12. Overrunning Clutch
- 13. Clutch Ring Gear

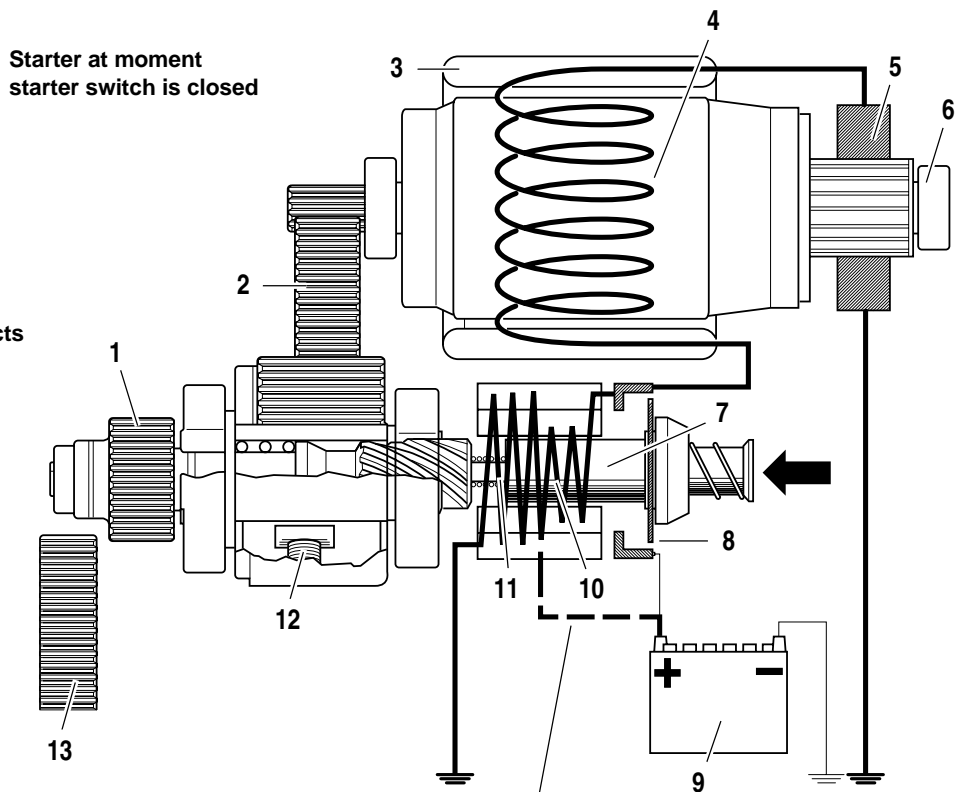

Starting circuit-see wiring diagram

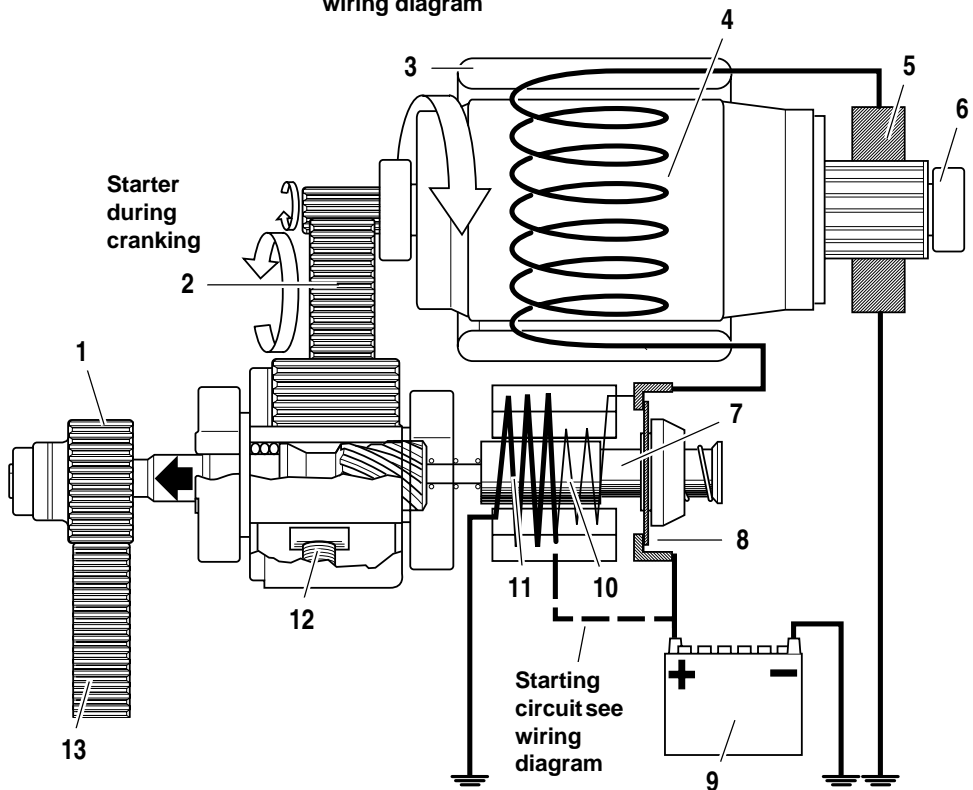

Starting circuit see wiring diagram

Figure 5-1. Starter Operation

SOURCE OF PROBLEM	PROBABLE CAUSE	SOLUTION
Battery	Voltage drop due to discharged battery.	Charge battery.
	Short-circuit or open between electrodes.	Replace battery.
	Poor contact condition of battery terminal(s).	Clean and retighten.
Wiring	Disconnection between starter switch and solenoid terminal.	Repair or replace wire.
	Malfunction in starter interlock system.	See 7.11 STARTER/IGNITION INTERLOCK
Starting Switch or Starter Relay.	Poor contact condition or poor connection.	Replace
Solenoid	Poor contact condition caused by burnt contact.	Polish contact surface or replace solenoid assembly. Repair.
	Contact plate removed.	Replace solenoid assembly.
	Pull-in winding open or short-circuit.	
	Hold-in winding open.	Check brush spring tension.
Starting Motor	Poor contact condition of brushes. Commutator burnt.	Correct on lathe or replace.
	Commutator high mica.	Correct by undercutting.
	Field winding grounded.	Replace
	Armature winding grounded or short-circuited.	
	Reduction gears damaged.	
	Insufficient brush spring tension.	
	Disconnected lead wire between solenoid and field windings.	Repair or replace lead wire.
	Ball bearing sticks.	Replace bearing.
Battery	Voltage drop due to discharged battery.	Charge battery.
	Short-circuit or open between electrodes.	Replace battery.
	Poor contact condition of battery terminal(s).	Clean and retighten.
Wiring	Disconnection between starter switch and solenoid terminal.	Repair or replace wire.
Overrunning Clutch	Overrunning clutch malfunction (rollers or compression spring).	Replace overrunning clutch.
	Pinion teeth worn out.	
	Pinion does not run in overrunning direction.	
	Poor sliding condition of spline teeth.	Remove foreign materials, dirt, or replace overrunning clutch.
	Reduction gears damaged.	Replace overrunning clutch and idler gear.
Ring Gear	Excessively worn teeth.	Replace ring gear.
Solenoid	Return spring worn.	Replace solenoid.
	Coil layer shorted.	
	Contact plate melted and stuck.	
Starting Switch or Starter Relay.	Unopened contacts.	Replace starting switch or starter relay.
	Poor returning.	

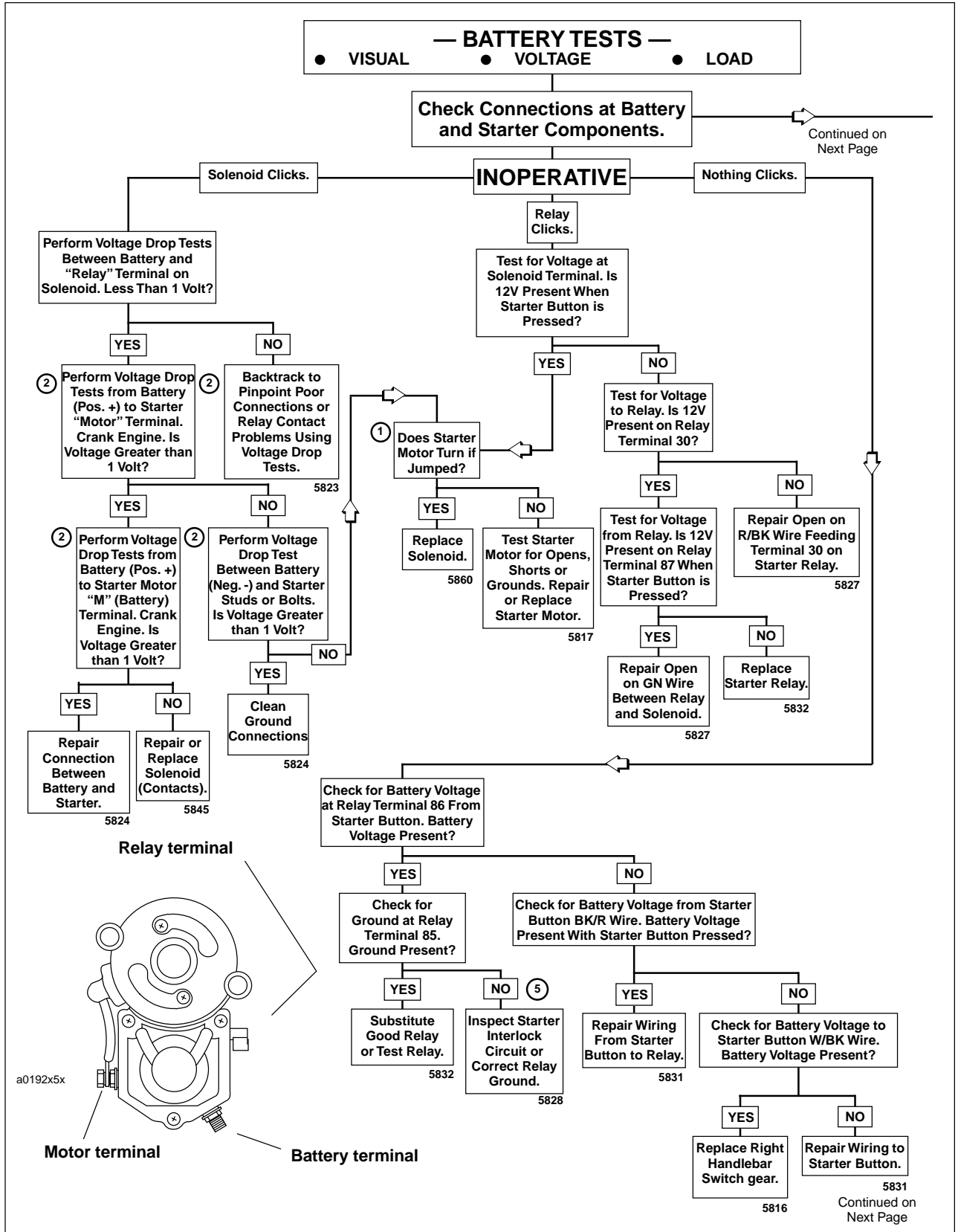

Figure 5-2. Starting System Diagnosis, Part 1

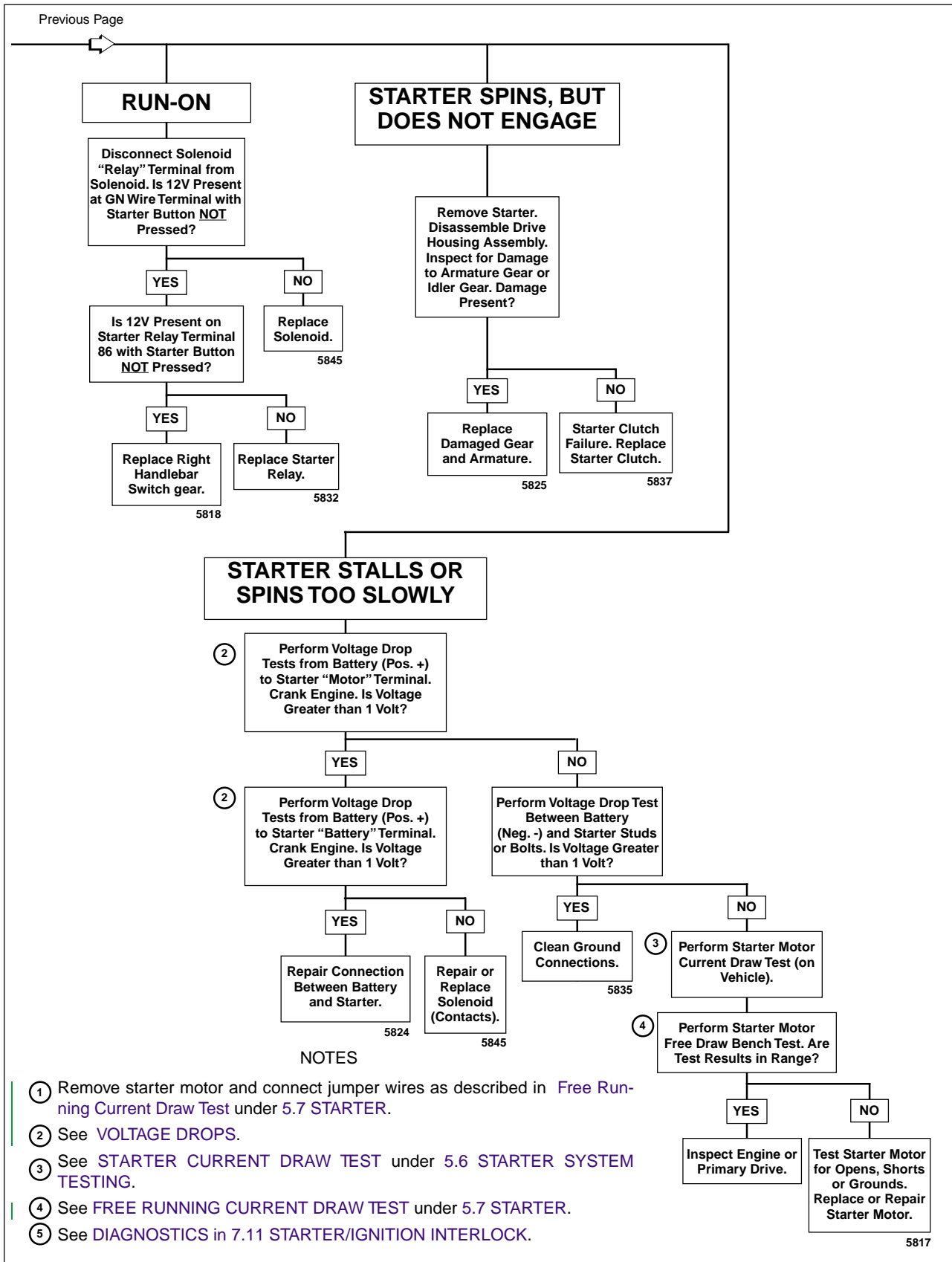

Figure 5-3. Starting System Diagnosis, Part 2

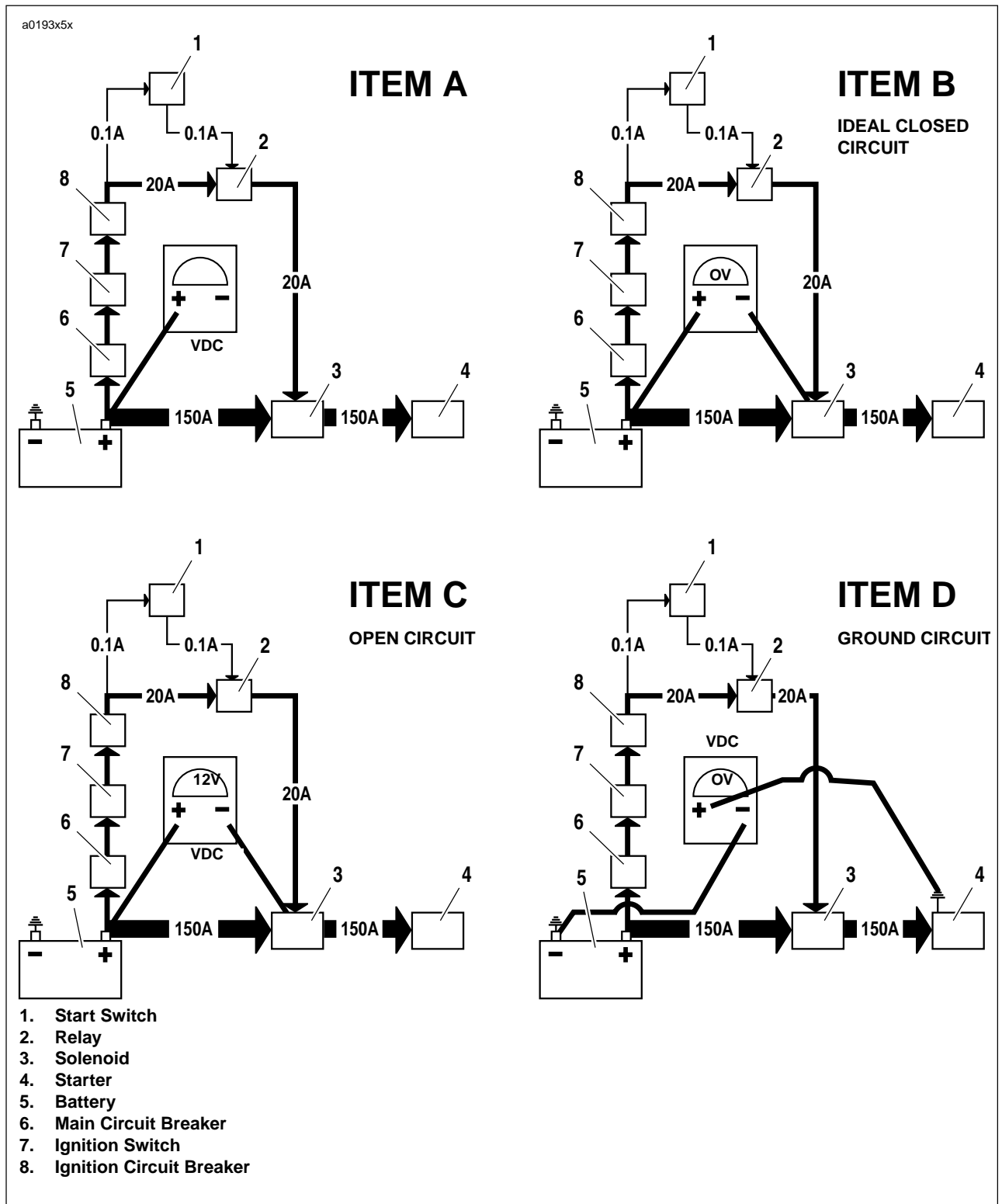

Figure 5-4. Typical Circuitry. Refer to wiring diagrams for more information.

GENERAL

The troubleshooting table beginning on [page 5-4](#) contains detailed procedures to solve and correct problems. Follow the [5.3 STARTER DIAGNOSTICS](#) diagram to diagnose starting system problems. The [VOLTAGE DROPS](#) procedure below will help you to locate poor connections or components with excessive voltage drops.

VOLTAGE DROPS

Check the integrity of all wiring, switches, circuit breakers and connectors between the source and destination.

The voltage drop test measures the difference in potential or the actual voltage dropped between the source and destination.

1. See [ITEM A](#) in [Figure 5-4](#). Attach your red meter lead to the most positive part of the circuit, which in this case would be the positive post of the battery (5).
2. See [ITEM B](#) in [Figure 5-4](#). Attach the black meter lead to the final destination or component in the circuit (solenoid terminal from relay).
3. Activate the starter and observe the meter reading. The meter will read the voltage dropped or the difference in potential between the source and destination.
4. An ideal circuit's voltage drop would be 0 volts or no voltage dropped, meaning no difference in potential.
5. See [ITEM C](#) in [Figure 5-4](#). An open circuit should read 12 volts, displaying all the voltage dropped, and the entire difference in potential displayed on the meter.
6. Typically, a good circuit will drop less than 1 volt.
7. If the voltage drop is greater, back track through the connections until the source of the potential difference is found. The benefit of doing it this way is speed.
 - a. Readings aren't as sensitive to real battery voltage.
 - b. Readings show the actual voltage dropped, not just the presence of voltage.
 - c. This tests the system as it is actually being used. It is more accurate and will display hard to find poor connections.
 - d. This approach can be used on lighting circuits, ignition circuits, etc. Start from most positive and go to most negative (the destination or component).
8. See [ITEM D](#) in [Figure 5-4](#). The negative or ground circuit can be checked as well.
 - a. Place the negative lead on the most negative part of the circuit (or the negative battery post). Remember, there is nothing more negative than the negative post of the battery.
 - b. Place the positive lead to the ground you wish to check.
 - c. Activate the circuit. This will allow you to read the potential difference or voltage dropped on the negative or ground circuit. This technique is very effective for identifying poor grounds due to powdered paint. Even the slightest connection may cause an ohmmeter to give a good reading. However, when sufficient current is passed through, the resistance caused by the powdered paint will cause a voltage drop or potential difference in the ground circuit.

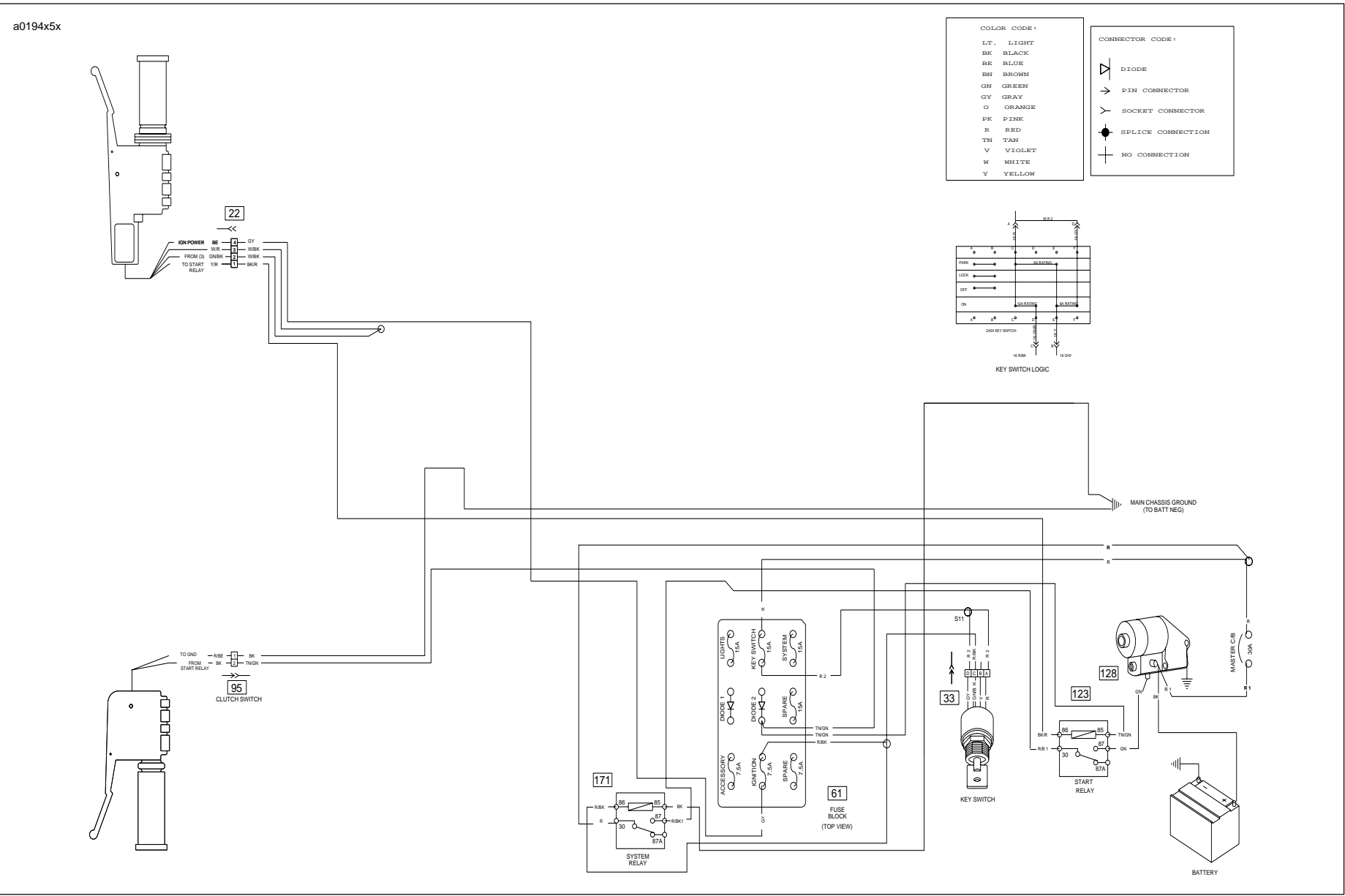

Figure 5-5. Electrical Starting System Circuit

“ON-MOTORCYCLE” TESTS

Starter Relay Test

1. See [Figure 5-6](#). Locate starter relay. The relay is attached to relay connector [123] located to the right of the battery underneath the seat.
2. To test relay, proceed to Step 3. If installing a **new** starter relay, remove old relay. Install relay connector [123] to **new** relay.
3. See [Figure 5-7](#). Obtain a 12 volt battery and a continuity tester or ohmmeter.
 - a. Pull relay from relay block.
 - b. Connect positive battery lead to the 86 terminal.
 - c. Connect negative battery lead to the 85 terminal to energize relay.
 - d. Check for continuity between the 30 and 87 terminals. A good relay shows continuity (continuity tester lamp “on” or a zero ohm reading on the ohmmeter). A malfunctioning relay will not show continuity and must be replaced.
4. If starter relay is functioning properly, proceed to [STARTER CURRENT DRAW TEST](#).

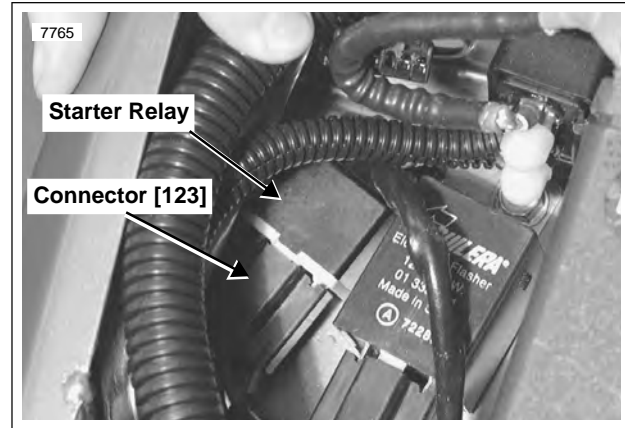

Figure 5-6. Starter Relay Connector

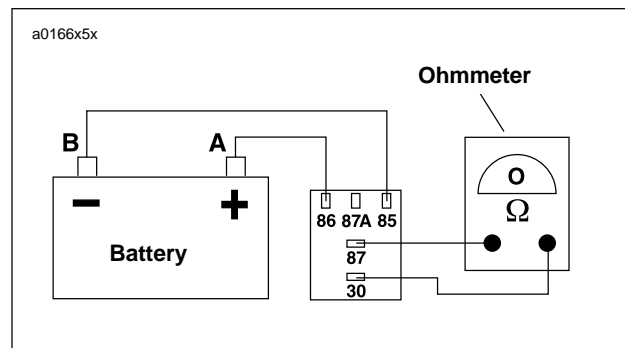

Figure 5-7. Starter Relay Test

Starter Current Draw Test

NOTE

- Engine temperature should be stable and at room temperature.
- Battery should be fully charged.

See [Figure 5-8](#). Check starter current draw with an induction ammeter before disconnecting battery. Proceed as follows:

1. Verify that transmission is in neutral. Disconnect spark plug wires from spark plug terminals.
2. Clamp induction ammeter over positive battery cable next to starter.
3. With ignition key switch ON, turn engine over by pressing starter switch while taking a reading on the ammeter.

Disregard initial high current reading which is normal when engine is first turned over.

- a. Typical starter current draw will range between 80-130 amperes.
- b. If starter current draw exceeds 130 amperes, then the problem may be in the starter or starter drive. Remove starter for further tests. See [5.7 STARTER](#).

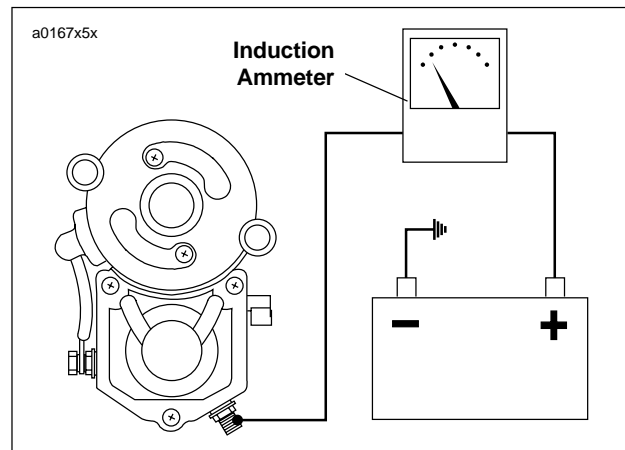

Figure 5-8. Starter Draw Test

REMOVAL

1. Remove seat. See 2.29 SEAT.

⚠ WARNING

To avoid accidental start-up of vehicle and possible personal injury, disconnect the battery cables before proceeding. Inadequate safety precautions could result in death or serious injury.

⚠ WARNING

Always disconnect the negative cable first. If the positive cable should contact ground with the negative cable installed, the resulting sparks may cause a battery explosion which could result in death or serious injury.

2. Disconnect battery cables from battery, negative cable first.
3. Remove air cleaner. See 4.3 AIR CLEANER.
4. Remove left side footpeg support bracket and primary cover. See 2.22 FOOTPEGS AND FOOTPEG SUPPORT BRACKETS.
5. See Figure 5-9. Remove locknut and clamp that secure oil hoses on right side of motorcycle.
6. Push hoses to either side to allow access to starter.
7. See Figure 5-10. Remove both starter mounting bolts and washers.

NOTE

A ball hex driver may be required to gain access to the starter mounting bolts.

8. See Figure 5-11. Remove positive battery cable from solenoid.
 - a. Remove protective boot if present.
 - b. Remove nut with washer (metric) that attaches positive battery cable to post.
 - c. Remove positive battery cable ring terminal.
 - d. Detach solenoid connector [128].
9. Remove starter and gasket.

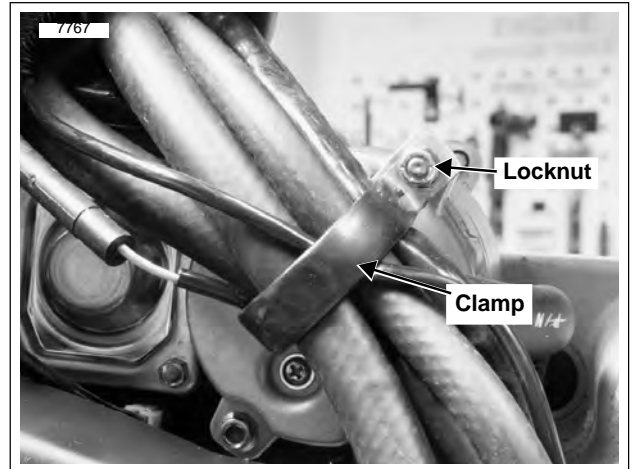

Figure 5-9. Oil Hose Clamps

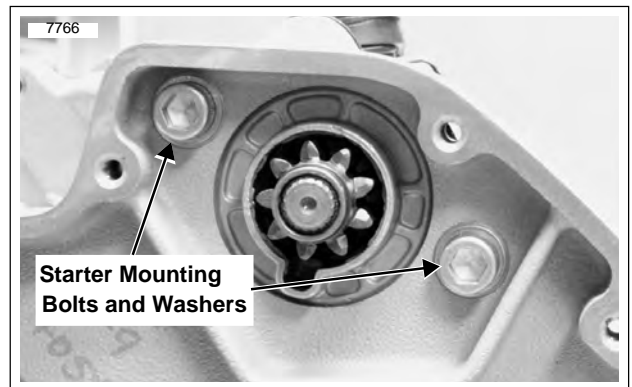

Figure 5-10. Starter Mounting (Primary Side)

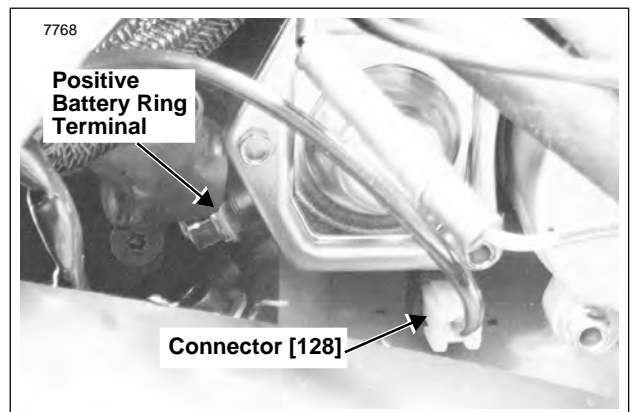

Figure 5-11. Starter Wires

TESTING ASSEMBLED STARTER

Free Running Current Draw Test

- Place starter in vise, using a clean shop towel to prevent scratches or other damage.
 - See [Figure 5-12](#). Attach one heavy jumper cable (6 gauge minimum).
 - To the starter mounting flange (1).
 - To the negative (-) terminal of a fully charged battery.
 - Connect a second heavy jumper cable (6 gauge minimum).
 - To the positive (+) terminal of the battery.
 - To an inductive ammeter (2). Continue on to the battery terminal (3) on the starter solenoid.
 - Connect a smaller jumper cable (14 gauge minimum).
 - To the positive (+) terminal of the battery.
 - To the solenoid relay terminal (4).
 - Check ammeter reading.
 - Ammeter should show 90 amps maximum.
- If reading is higher, disassemble starter for inspection.
- If starter current draw on vehicle was over 130 amps and this test was within specification, there may be a problem with engine or primary drive.

Starter Solenoid

NOTE

Do not disassemble solenoid. Before testing, disconnect field wire from motor terminal as shown in [Figure 5-13](#).

CAUTION

Each test should be performed for only 3-5 seconds to prevent damage to solenoid.

NOTE

The solenoid Pull-in, Hold-in, and Return tests must be performed together in one continuous operation. Conduct all three tests one after the other in the sequence given without interruption.

Solenoid Pull-in Test

- See [Figure 5-13](#). Using a 12 volt battery, connect three separate test leads as follows:
 - Solenoid housing to negative battery post.
 - Solenoid motor terminal to negative battery post.
 - Solenoid relay terminal to positive battery post.
- Observe starter pinion.
 - If starter pinion pulls in strongly, solenoid is working properly.
 - If starter pinion does not pull in, replace the solenoid.

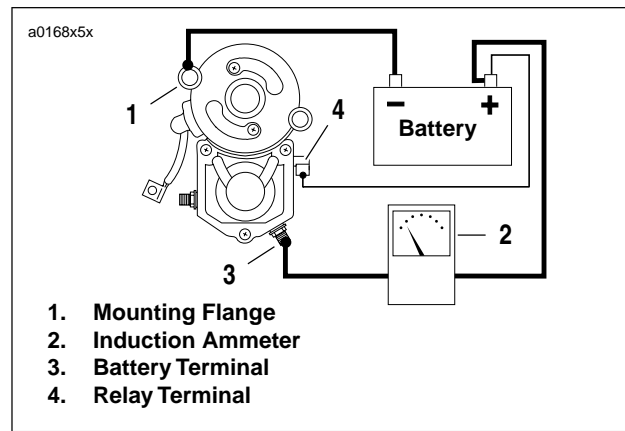

Figure 5-12. Free Running Current Draw Test

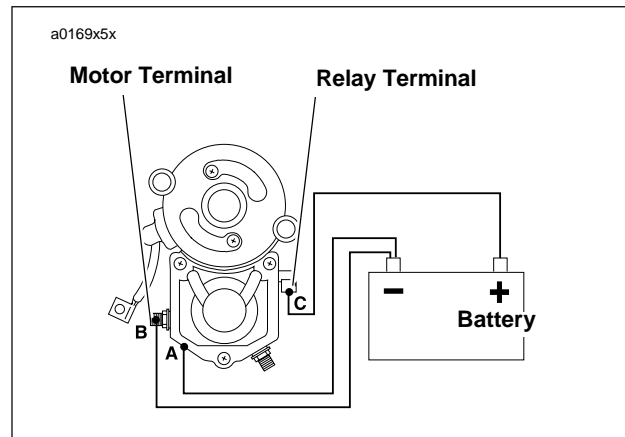

Figure 5-13. Pull-In Test

Solenoid Hold-in Test

1. See Figure 5-14. With test leads still connected in the manner specified in the previous **SOLENOID PULL-IN TEST**, **disconnect solenoid motor terminal/battery negative test lead (B) at negative battery post only; reconnect loose end of this test lead to positive battery post instead.**
2. Observe starter pinion.
 - a. If starter pinion remains in pull-in position, solenoid is working properly.
 - b. If starter pinion does not remain in pull-in position, replace the solenoid.

Solenoid Return Test

1. See Figure 5-15. With test leads still connected in the manner specified at the end of the previous **SOLENOID HOLD-IN TEST**, **disconnect solenoid relay terminal/positive battery post test lead (C) at either end.**
2. Observe starter pinion.
 - a. If starter pinion returns to its original position, solenoid is working properly.
 - b. If starter pinion does not return to its original position, replace the solenoid.

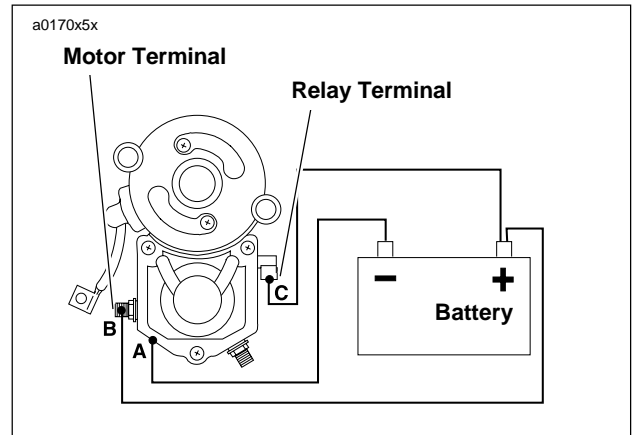

Figure 5-14. Hold-In Test

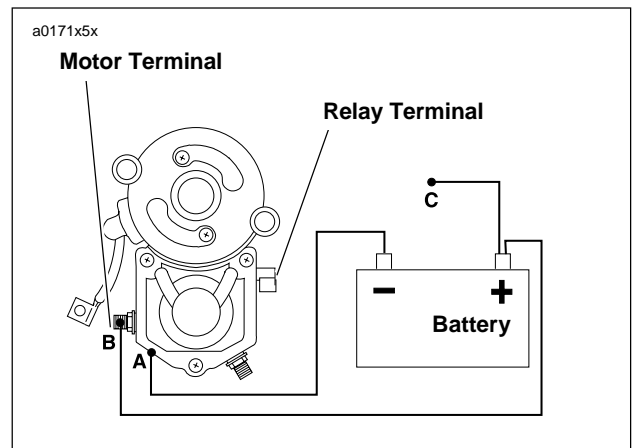

Figure 5-15. Return Test

DISASSEMBLY AND INSPECTION

1. See [Figure 5-16](#). Lift rubber boot (1). Remove field wire nut with washer (2) (metric) to detach field wire (3).
2. See [Figure 5-17](#). Remove both thru-bolts (1, 3).
3. Remove both end cover screws with O-rings (2) and end cover (4).
4. See [Figure 5-18](#). Use a wire hook to pull upward on brush springs (3), and lift brushes out of holder (2). Remove brush holder.
5. Check brush length. Replace all four brushes if length of any one brush is less than 0.433 in. (11.0 mm).

NOTE

Brushes not available separately. Purchase a **new** field frame (1) and brush holder (2) to replace brushes.

6. Remove armature (4) and field frame (1).
7. Place armature in lathe or truing stand and check commutator runout and diameter.
 - a. Commutators with more than 0.016 in. (0.406 mm) of runout should be replaced or machined on a lathe.
 - b. Replace commutators when diameter is less than 1.141 in. (28.981 mm)
 - c. Check armature bearings. Replace if necessary.

CAUTION

Do not use sandpaper or emery cloth to remove burrs on commutator. Otherwise, abrasive grit may remain on commutator segments; this could lead to excessive brush wear. Use only the recommended crocus cloth.

8. Check depth of mica on commutator. If undercut is less than 0.008 in. (0.203 mm), use an undercutting machine to undercut the mica to 1/32 in. (0.794 mm) deep. The slots should then be cleaned to remove any dirt or copper dust.

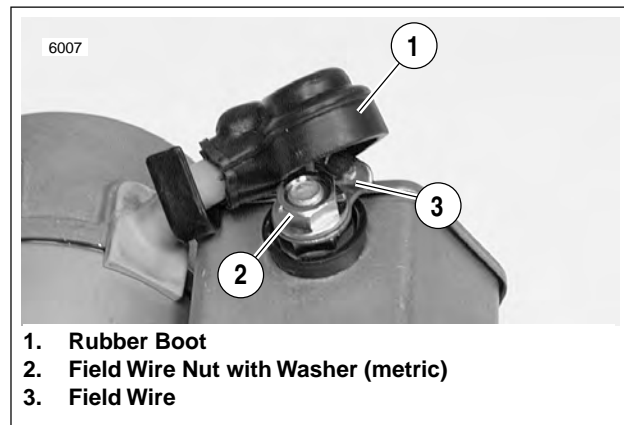

Figure 5-16. Field Wire

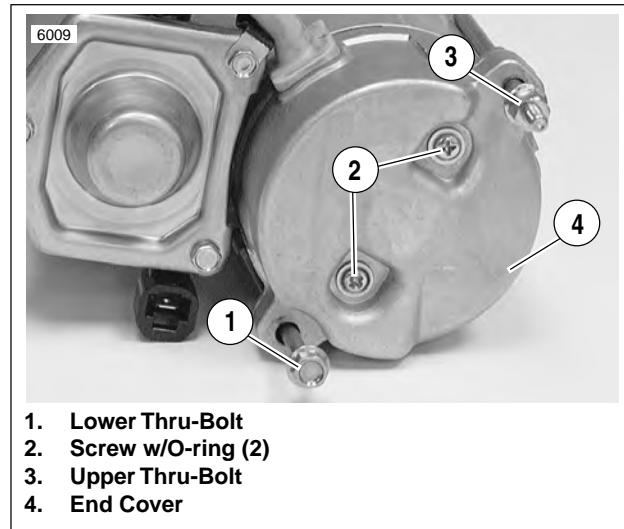

Figure 5-17. Removing the Thru-Bolts

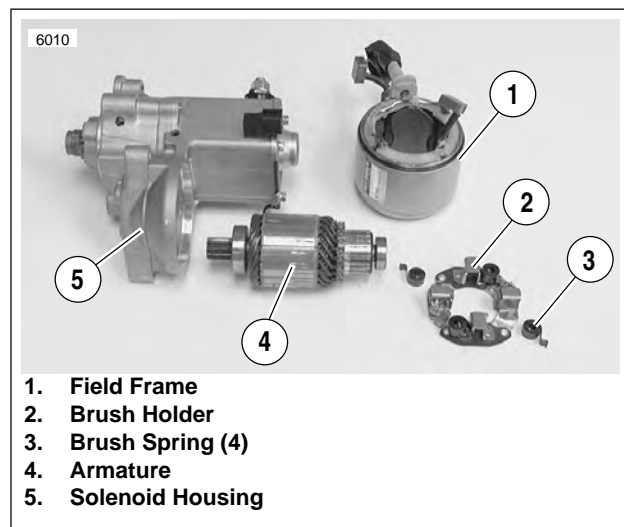

Figure 5-18. Starter Components

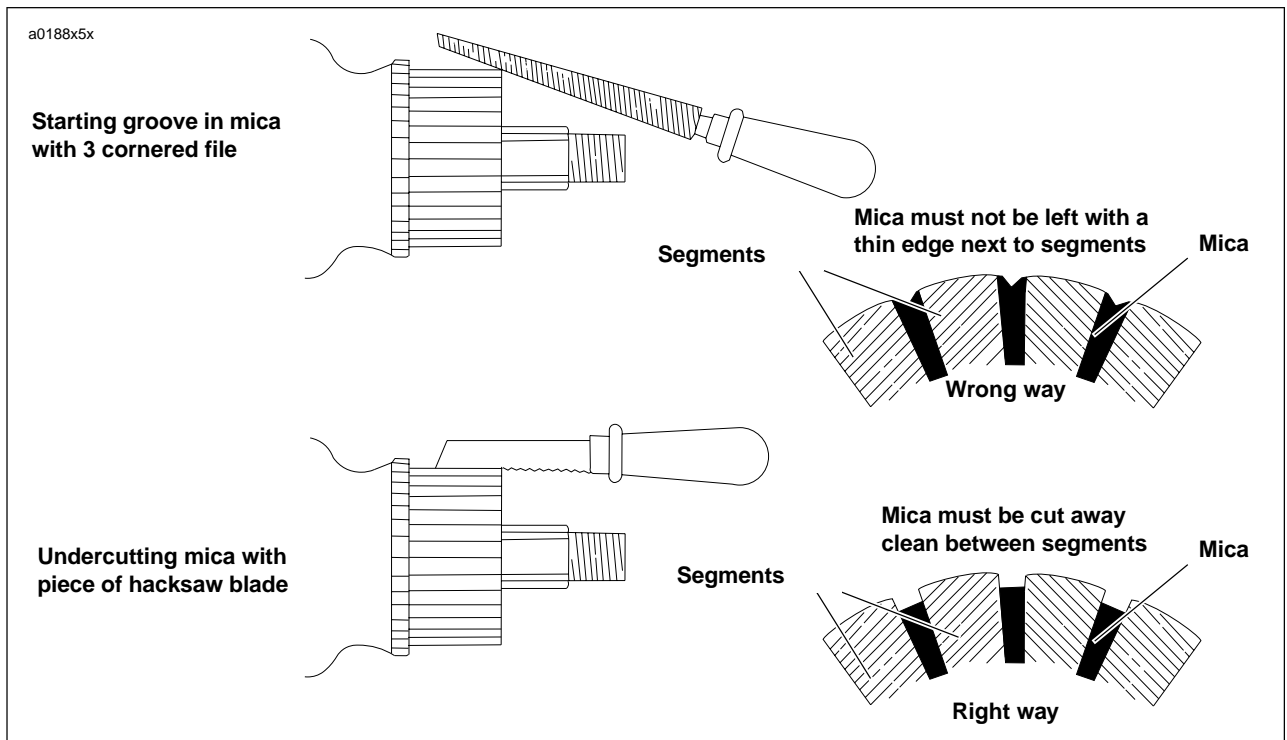

Figure 5-19. Undercutting Mica Separators

NOTE

See [Figure 5-19](#). If an undercutting machine is not available, undercutting can be done satisfactorily using a thin hacksaw blade. After undercutting, lightly sand the commutator with crocus cloth to remove any burrs.

9. See [Figure 5-20](#). Check for SHORTED ARMATURE with a growler.
 - a. Place armature on growler (1).
 - b. Hold a thin steel strip (2) (hacksaw blade) against armature core and slowly turn armature.
 - c. A shorted armature will cause the steel strip to vibrate and be attracted to the core. Replace shorted armatures.
10. See [Figure 5-21](#). Check for a GROUNDED ARMATURE with an ohmmeter or continuity tester.
 - a. Touch one probe to any commutator segment (1).
 - b. Touch the other probe to the armature core (2).
 - c. There should be no continuity (infinite ohms). If there is continuity, then the armature is grounded. Replace grounded armatures.

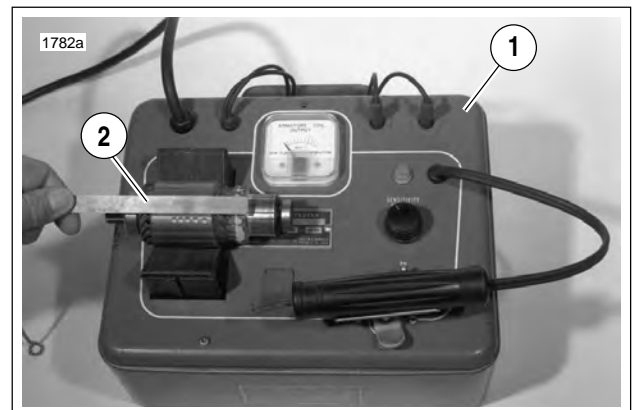

Figure 5-20. Shorted Armature Test Using Growler

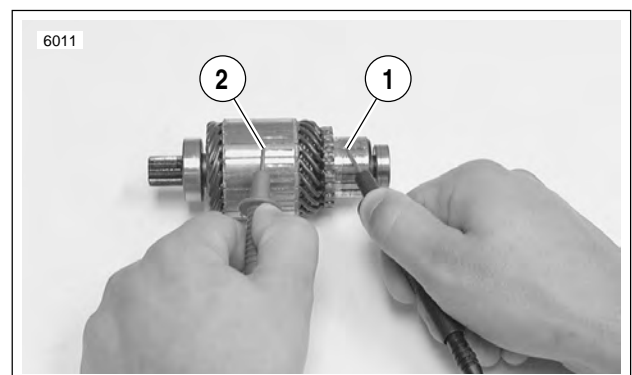

Figure 5-21. Grounded Armature Test

11. See [Figure 5-22](#). Check for OPEN ARMATURE with an ohmmeter or continuity tester.
 - a. Check for continuity between all commutator segments (1).
 - b. There should be continuity (0 ohms) at all test points. No continuity at any test point indicates armature is open and must be replaced.
12. See [Figure 5-23](#). Check for GROUNDED FIELD COIL with an ohmmeter or continuity tester.
 - a. Touch one probe to the frame (1).
 - b. Touch the other probe to each of the brushes (2) attached to the field coil.
 - c. There should be no continuity (infinite ohms). If there is any continuity at either brush, then the field coil(s) are grounded and the field frame must be replaced.
13. See [Figure 5-24](#). Check for OPEN FIELD COILS with an ohmmeter or continuity tester.
 - a. Touch one probe to the field wire (1).
 - b. Touch the other probe to each of the brushes attached to the field coil(s) (2).
 - c. There should be continuity (0 ohms). If there is no continuity at either brush, then the field coil(s) are open and the field frame must be replaced.
14. See [Figure 5-25](#). Test BRUSH HOLDER INSULATION with an ohmmeter or continuity tester.
 - a. Touch one probe to holder plate (1).
 - b. Touch the other probe to each of the positive (insulated) brush holders (2).
 - c. There should be no continuity (infinite ohms). If there is continuity at either brush holder, replace the brush holder assembly.
15. See [Figure 5-26](#). Remove two drive housing mounting screws (6). Remove drive housing (5) from solenoid housing.
16. Remove drive (1), idler gear (2), idler gear bearing (3), and O-ring (4) from drive housing (O-ring is located in drive housing groove).

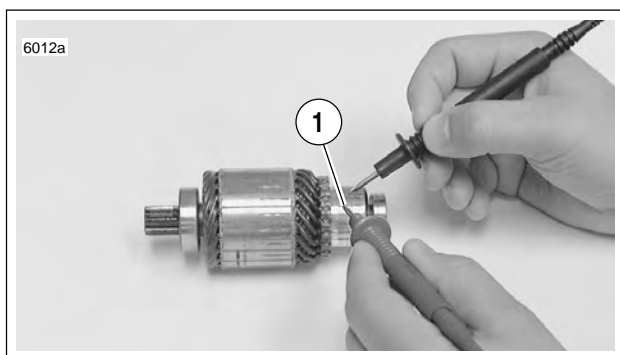

Figure 5-22. Open Armature Test

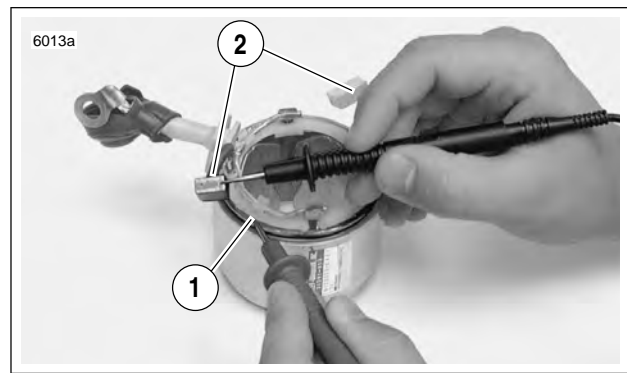

Figure 5-23. Grounded Field Test

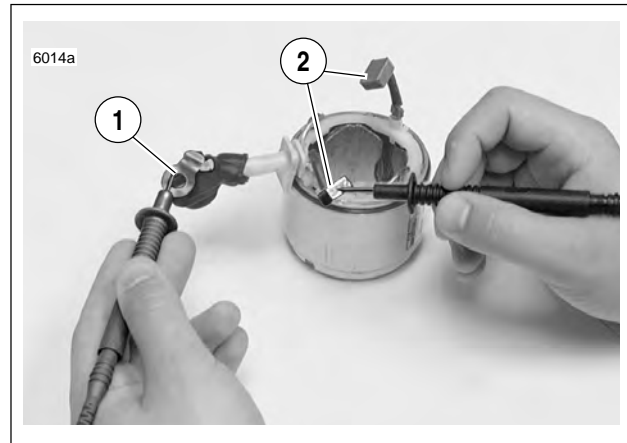

Figure 5-24. Open Field Test

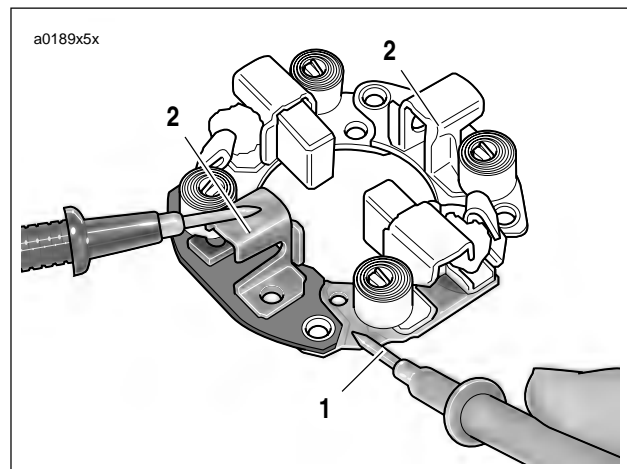

Figure 5-25. Brush Holder Insulation Test

ASSEMBLY

1. See Figure 5-26. Clean, inspect and lubricate drive assembly components. Lubricate parts with high temperature grease, such as LUBRIPLATE 110.
2. See Figure 5-27. When installing drive assembly components, open end of idler bearing cage (15) faces toward solenoid.
3. When installing drive housing (10) to solenoid housing (11), use **new** O-ring (16). Be sure to install return spring (17) and ball (18).
4. Lubricate armature bearings (8) with high temperature grease, such as LUBRIPLATE 110. Install armature (6) and field frame (7) to solenoid housing (11).
5. Install brushes and brush holder (4).
6. Install O-rings (23). Attach end cover (3) with end cover screws and O-rings (2).
7. Install thru-bolts (1).
8. Attach field wire (22) to solenoid housing (11) with field wire nut and washer (24) (metric). Replace rubber boot.

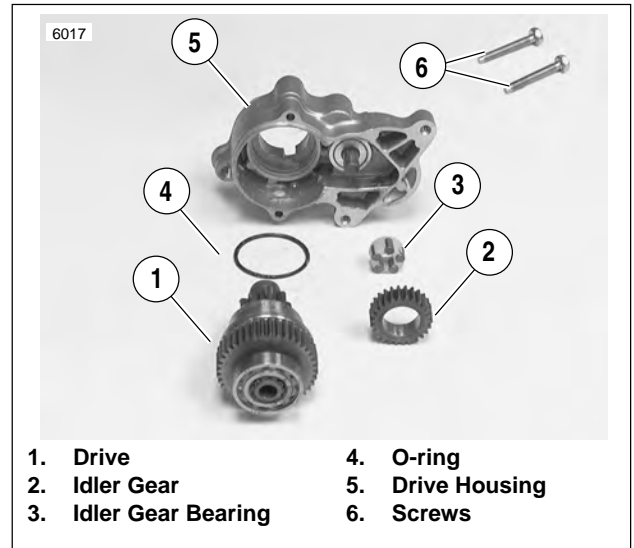

Figure 5-26. Starter Drive Assembly

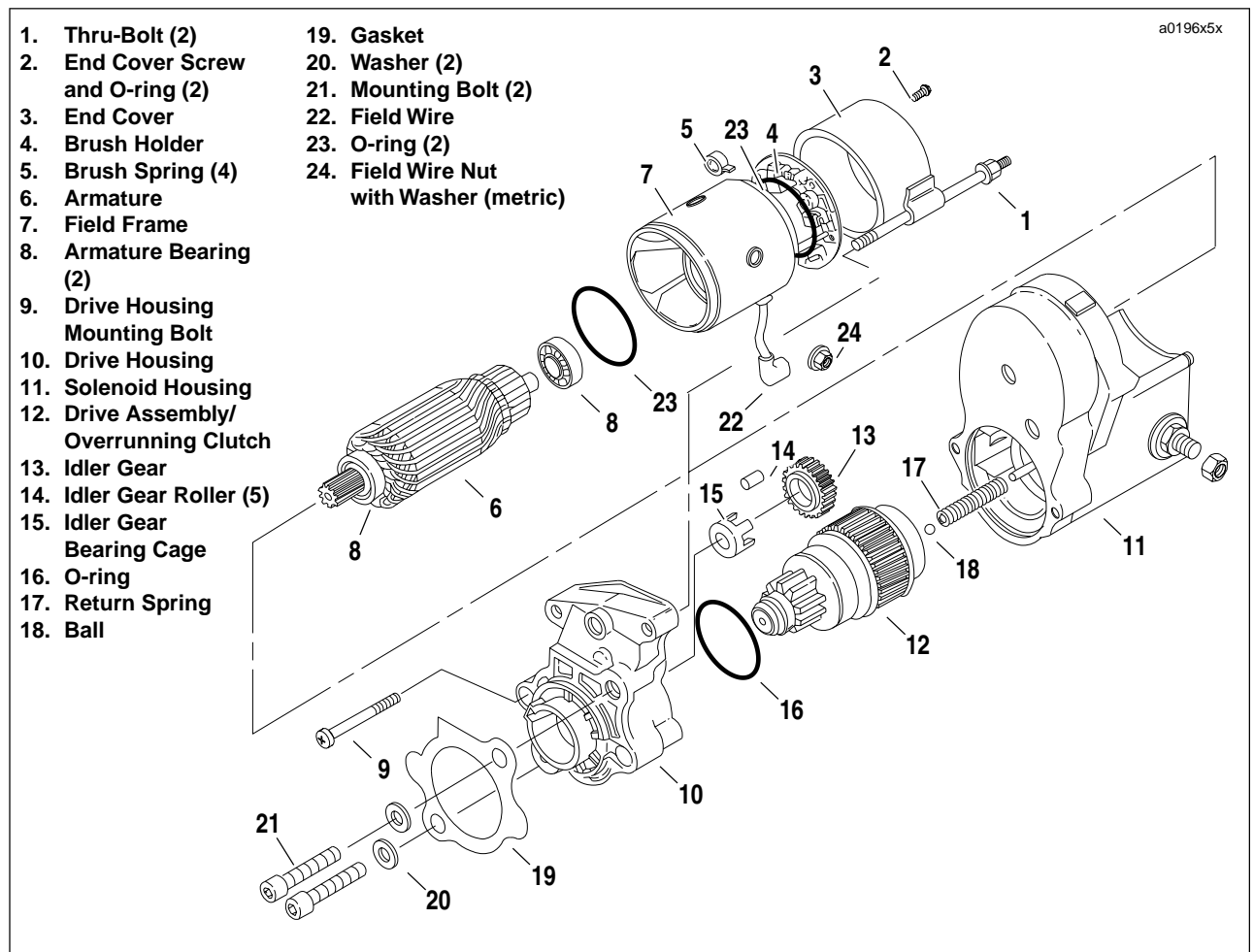

Figure 5-27. Starter Assembly

INSTALLATION

1. Install starter and starter gasket from the right side.
2. See [Figure 5-28](#). Connect wiring to starter.
 - a. Connect solenoid wire (3).
 - b. Attach positive battery cable ring terminal (2).
 - c. Install nut with washer (1) (metric). Tighten to 60-85 **in-lbs** (6.8-9.6 Nm).
 - d. Replace protective boot.
3. See [Figure 5-29](#). Install both starter mounting bolts and washers. Tighten to 13-20 ft-lbs (17.6-27.1 Nm).
4. Position oil hoses in clamp and install clamp to through bolt with **new** locknut. Make sure hoses are not kinked or restricted.
5. Install primary cover. See [6.2 PRIMARY CHAIN](#).
6. Fill transmission to proper level with fresh lubricant. See [1.10 TRANSMISSION/PRIMARY FLUID](#).
7. Install left side footrest support assembly. See [2.22 FOOTPEGS AND FOOTPEG SUPPORT BRACKETS](#).
8. Install air cleaner. See [4.3 AIR CLEANER](#).

⚠ WARNING

Always connect positive battery cable first. If the positive cable should contact ground with the negative cable installed, the resulting sparks could cause a battery explosion which could result in death or serious injury.

9. Connect battery cables, positive cable first. Tighten terminal hardware to 60-96 **in-lbs** (7-11 Nm).
10. Install seat. See [2.29 SEAT](#).

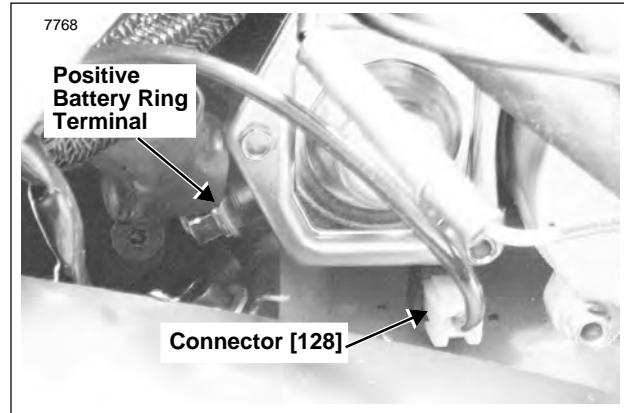

Figure 5-28. Starter Wires

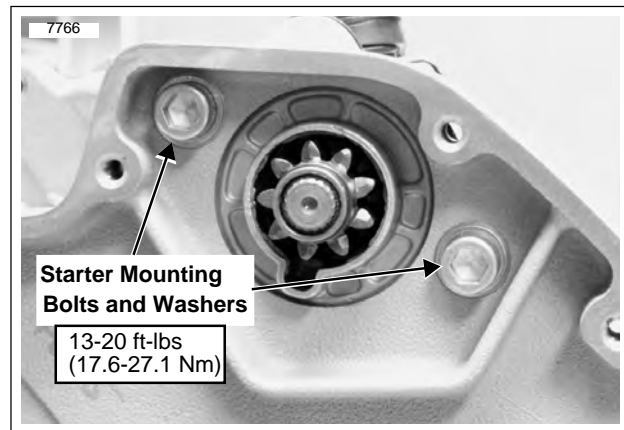

Figure 5-29. Starter Mounting (Primary Side)

GENERAL

CAUTION

See [Figure 5-30](#). Do not tighten nut (7) without removing items 1-5. Movement will cause damage to the contact.

The starter solenoid is a switch that is designed to open and close the starting circuit electromagnetically. The switch consists of contacts and a winding around a hollow cylinder containing a movable plunger.

DISASSEMBLY

1. See [Figure 5-30](#). Remove screws (1) and clip (2).
2. Remove cover (3) and gasket (4). Discard gasket.
3. Remove plunger (5) from solenoid housing (6).

ASSEMBLY

1. See [Figure 5-30](#). Replace wire connection hardware as necessary.
2. Install plunger (5) in solenoid housing (6).
3. Install **new** gasket (4) onto cover (3).
4. Position cover with gasket onto solenoid housing. Install clip (2) and screws (1).

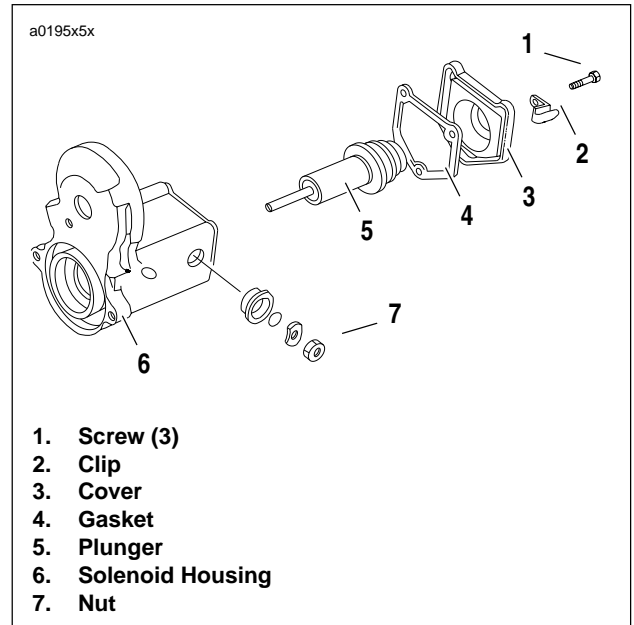

Figure 5-30. Starter Solenoid

NOTES

[Table Of Contents](#)

DRIVE/TRANSMISSION 6

SUBJECT	PAGE NO.
6.1 Specifications	6-1
6.2 Primary Chain	6-3
6.3 Secondary Drive Belt	6-7
6.4 Clutch	6-10
6.5 Clutch Release Mechanism	6-12
6.6 Primary Drive/Clutch	6-14
6.7 Transmission	6-21
6.8 Transmission Case	6-22
6.9 Transmission Disassembly	6-24
6.10 Transmission Assembly	6-29
6.11 Main Drive Gear	6-33
6.12 Right Transmission Case Bearings	6-35
6.13 Left Crankcase Bearings	6-37
6.14 Transmission Installation/Shifter Pawl Adjustment	6-39

NOTE

Service wear limits are given as a guideline for measuring components that are not new. For measurement specifications not given under SERVICE WEAR LIMITS, see NEW COMPONENTS.

ITEM	NEW COMPONENTS	Service Wear Limits
Primary Drive (Engine-to-Transmission)		
Engine sprocket – number of teeth	35	N/A
Clutch sprocket – number of teeth	56	N/A
Ratio*	1.60:1	N/A
Final Drive (Transmission-to-Rear Wheel)		
Transmission sprocket – number of teeth	27	N/A
Rear wheel sprocket – number of teeth	80	Replace at 15,000 mi
Secondary drive belt – number of teeth	139	Replace at 15,000 mi
Ratio	2.96:1	N/A
Transmission		
Primary drive / transmission lubricant capacity	32 fl. oz. (946 ml)	N/A
Overall gear ratios**		
First gear (low)	12.74	N/A
Second gear	8.77	N/A
Third gear	6.79	N/A
Fourth gear	5.60	N/A
Fifth gear (high)	4.74	N/A

* Internal gear ratios indicate number of mainshaft revolutions required to drive output sprocket one revolution.

** Overall gear ratios indicate number of engine revolutions required to drive rear wheel one revolution.

WET CLUTCH Multiple disc		
CLUTCH PLATE THICKNESS		
Friction plate (fiber) (in.)	0.0866 + 0.0031	N/A
Friction plate (fiber) (mm)	2.200 + 0.079	N/A
Steel plate (in.)	0.0629 + 0.0020	N/A
Steel plate (mm)	1.598 + 0.051	N/A
Clutch pack (in.)	N/A	.413 in. (minimum)
Clutch pack (mm)	N/A	(16.787)
MAXIMUM ALLOWABLE WARPAGE		
Friction plate (fiber) (in.)	N/A	0.0059
Friction plate (fiber) (mm)	N/A	0.150
Steel plate (in.)	N/A	0.0059
Steel plate (mm)	N/A	0.150

TORQUE VALUES

ITEM	TORQUE		NOTES
Clutch Inspection Cover Screws	7-9 ft-lbs	9.5-12.2 Nm	Tighten crosswise pattern, page 6-11
Clutch Mainshaft Nut	70-80 ft-lbs	94.9-108.5 Nm	LOCTITE® thread locker 262 (red), left hand threads, page 6- 20
Crankcase 1/4 in. Screws	80-100 in-lbs	9.0-12.4 Nm	LOCTITE® thread locker 262 (red), page 6-39
Crankcase 5/16 in. Screws	15-19 ft-lbs	20.3-25 Nm	LOCTITE® thread locker 262 (red), page 6-39
Engine Sprocket Nut	190-210 ft-lbs	257.6-284.7 Nm	LOCTITE® thread locker 262 (red), page 6-20
Primary Cover Bolts	80-110 in-lbs	9.0-12.4 Nm	Follow torque sequence, page 6-6
Retention Collar Screw	13-17 ft-lbs	18-23 Nm	LOCTITE® thread locker 243 (blue), page 6- 41
Shift Lever Pinch Screw	12-14 ft-lbs	16.3-19.0 Nm	Page 6-6
Shifter Shaft Assembly Locknuts	90-110 in-lbs	10.2-12.4 Nm	Bottom nut first, same torque for top, page 6- 41
Transmission Drain Plug	14-30 ft-lbs	19.0-54 Nm	Remove debris from end, pages 6-6, 6-10
Transmission Sprocket Nut	See NOTES	See NOTES	LOCTITE® thread locker 262 (red), left hand threads, special torque turn method, page 6- 43
Transmission Sprocket Screws	90-110 in-lbs	10.2-12.4 Nm	Replace after 3 removals, page 6- 44

GENERAL

An opening between the primary drive and transmission compartments allows the same lubricant supply to lubricate moving parts in both compartments.

Since the primary chain runs in lubricant, little service will be required other than checking lubricant level and chain tension. If, through hard usage, the primary chain does become worn, it must be replaced. Remove and install the chain following the procedure under [6.6 PRIMARY DRIVE/CLUTCH](#).

REMOVAL

Primary Cover

1. Remove seat. See [2.29 SEAT](#).

WARNING

To protect against shock and accidental start-up of vehicle, disconnect the negative battery cable before proceeding. Inadequate safety precautions could result in death or serious injury.

2. Disconnect negative battery cable from battery.
3. See [Figure 6-1](#). Place a drain pan under the engine. Remove drain plug and drain lubricant from primary drive.
4. Remove shifter lever assembly and rubber washer. Do not scratch primary cover.

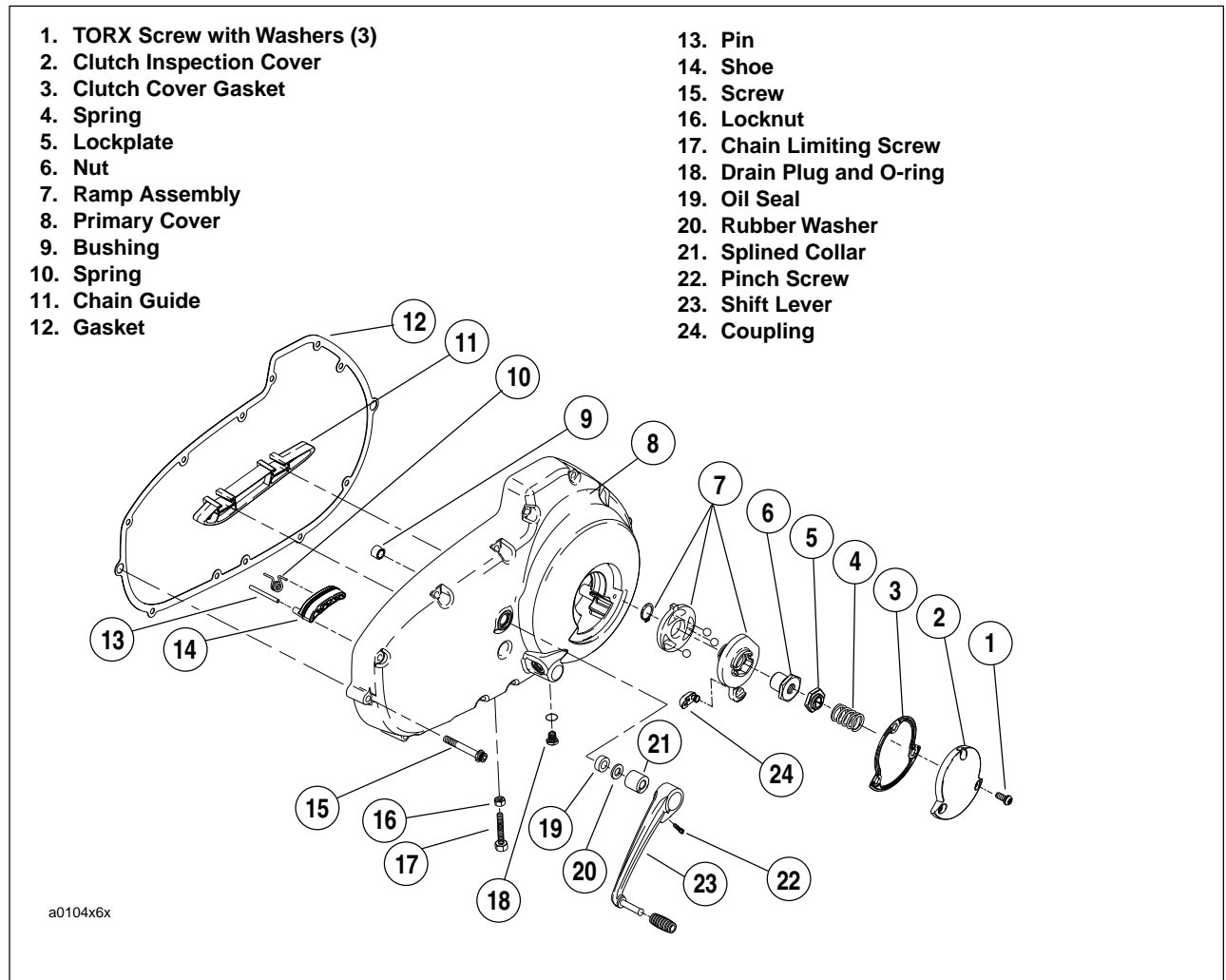

Figure 6-1. Primary Cover and Shifter Assembly

HOME

1. See [ADJUSTMENT](#) under [6.5 CLUTCH RELEASE MECHANISM](#). Add freeplay to clutch cable.
5. Loosen locknut. Turn chain adjuster screw counterclockwise (outward).
6. Remove left foot peg support bracket. See [2.22 FOOT-PEGS AND FOOTPEG SUPPORT BRACKETS](#).
7. Remove three TORX screws with washers and clutch inspection cover.
8. Remove and discard gasket from groove in primary cover.
9. Slide spring with attached hex lockplate from flats of clutch limiting screw.
10. Turn clutch adjusting screw clockwise to release ramp and coupling mechanism. As the limiting screw is turned, ramp assembly moves forward. Unscrew nut from end of limiting screw.
11. Remove hook of ramp from button to the rear of cable end coupling. Remove cable end from slot in coupling. Remove coupling and ramp assembly.
12. Remove screws which secure primary cover. Remove cover and gasket.
13. Discard gasket.
14. Remove and discard shifter lever oil seal.

Primary Chain Adjuster

1. See [Figure 6-2](#). Remove primary cover.
2. Loosen locknut from chain limiting screw. Turn limiting screw out of threaded boss in primary cover.
3. Slide shoe outward and remove.
4. Remove chain tensioner spring.

INSTALLATION

Primary Chain Adjuster

1. See [Figure 6-3](#). If shoe is badly worn, replace it.
2. Install chain tensioner spring into shoe.
3. Slide shoe onto pin.
4. Tilt shoe upward until spring aligns with crankcase mounting hole.
5. Tilt shoe downward under primary chain.
6. Press shoe inward.
7. Install primary cover. See [Primary Cover](#) in [6.2 PRIMARY CHAIN](#).

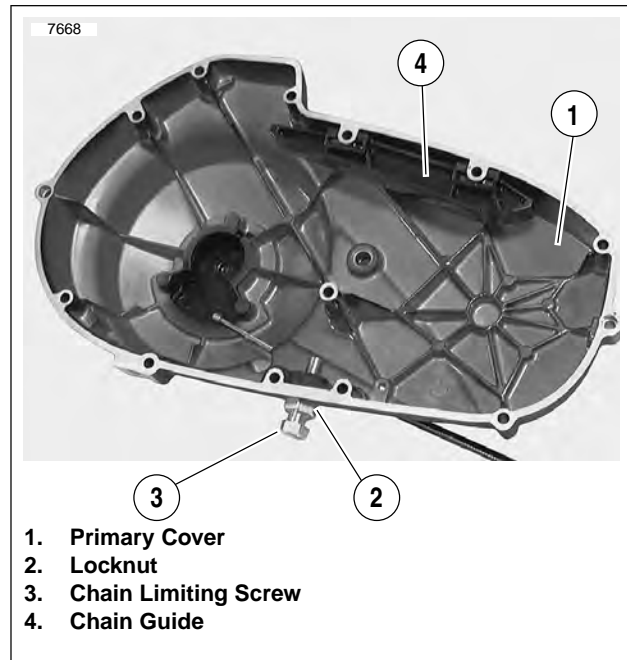

Figure 6-2. Removing Primary Chain Adjuster

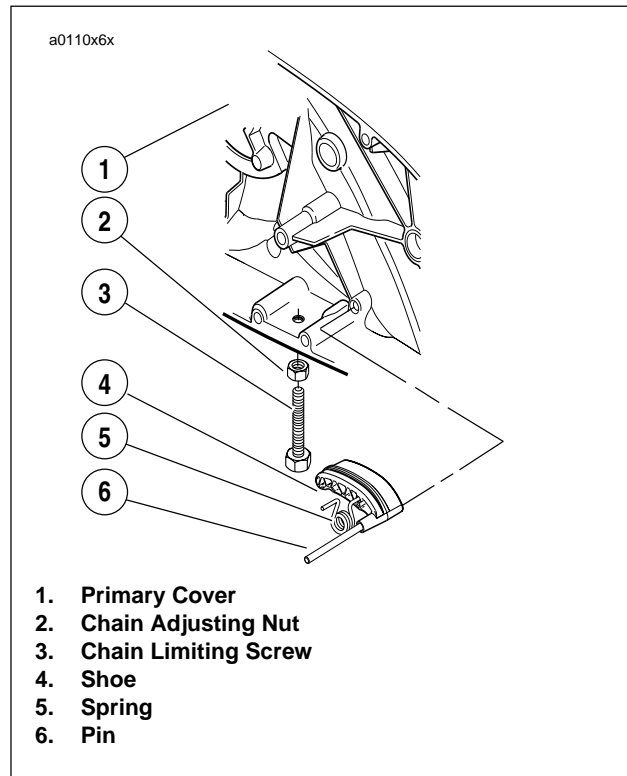

Figure 6-3. Primary Chain Adjuster

Primary Chain Adjustment

See [Figure 6-4](#). Buell Blast Models are shipped with a spacer between the primary chain limiting screw and the locknut. The spacer is used to quickly get proper adjustment during production. This spacer should be removed and discarded at the first adjustment interval.

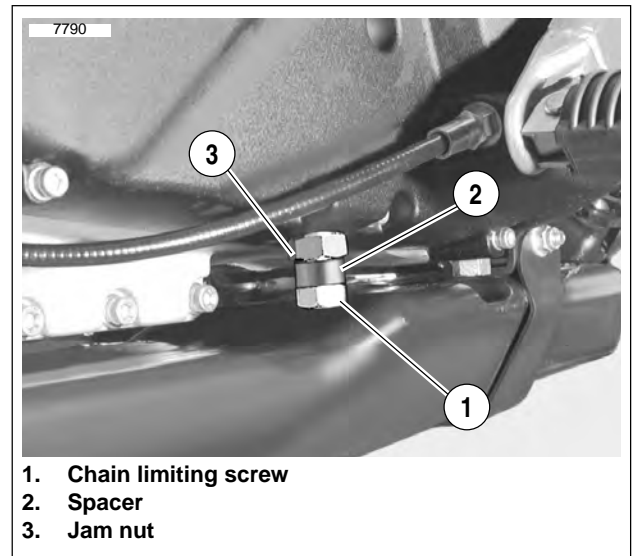

Figure 6-4. Adjustment Nut-with Spacer

1. See [Figure 6-5](#). Back-off locknut and chain limiting screw. Remove spacer.

IMPORTANT NOTE

Be certain to use **Inch-Pound Wrench**. Chain adjuster shoe can be damaged by excessive force.

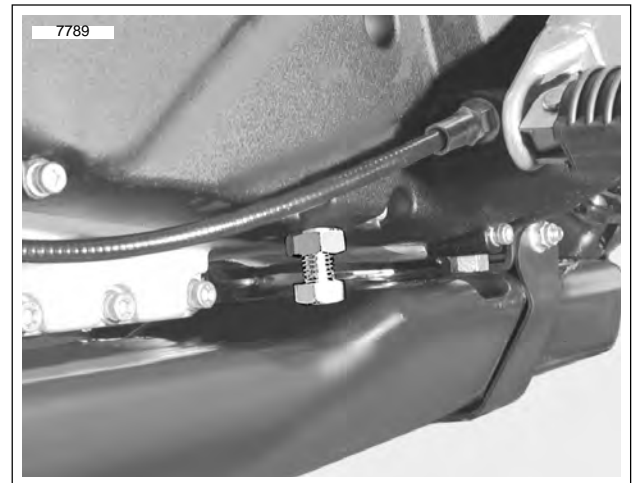

Figure 6-5. Chain Limiting Screw-without Spacer

2. See [Figure 6-6](#). Tighten chain limiting screw to 24 **in-lbs**.
3. Back-off chain limiting screw 3/4 turn (4 1/2 "flats").
4. Hold chain limiting screw while tightening jam nut.

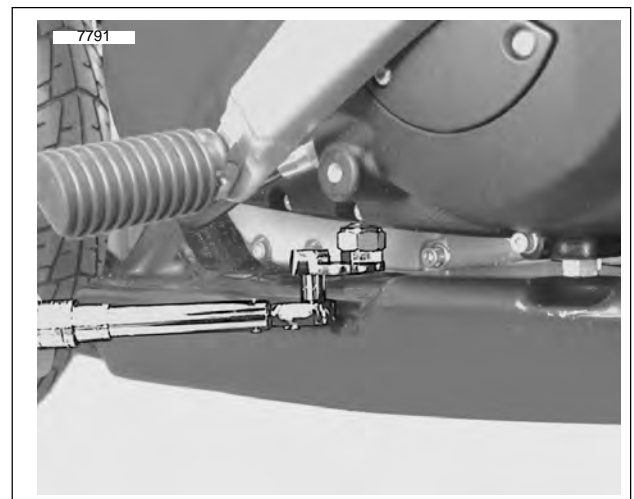

Figure 6-6. Torquing Chain Limiting Screw

Primary Cover

1. Remove foreign material from magnetic drain plug. Install plug and tighten to 14-30 ft-lbs (19-54 Nm).
2. Wipe gasket surface clean. Install **new** gasket on primary cover.
3. See [Figure 6-7](#). Install primary cover and gasket onto left crankcase half using mounting bolts.
 - a. Tighten bolts to 80-110 **in-lbs** (9-12.4 Nm) in sequence shown.
4. See [Figure 6-1](#). Install **new** shifter lever oil seal.
5. Fit coupling over cable end with rounded side inboard and the ramp connector button outboard. With retaining ring side of ramp assembly facing inward, place hook of ramp around coupling button and rotate assembly counterclockwise until tang on inner ramp fits in slot of primary cover.
6. Thread nut on adjustment screw until slot of screw is accessible with a screwdriver. Fit nut hex into recess of outer ramp and turn adjustment screw counterclockwise.
7. Adjust clutch. See [ADJUSTMENT](#) under [6.5 CLUTCH RELEASE MECHANISM](#).
8. Adjust primary chain tension. See [6.2 PRIMARY CHAIN](#).
9. Fill transmission to proper level with fresh lubricant. See [TRANSMISSION FLUID](#) under section [6.4 CLUTCH](#).
10. Install clutch inspection cover with **new** gasket and three TORX screws with washers. Tighten screws in a cross-wise pattern to 7-9 ft-lbs (9.5-12.2 Nm).
11. See [Figure 6-1](#). Install rubber washer and shifter lever assembly.
 - a. Tighten pinch screw to 12-14 ft-lbs 16.3-19.0 Nm)
12. Install left footpeg support bracket. See [2.22 FOOTPEGS AND FOOTPEG SUPPORT BRACKETS](#).
13. Connect negative battery cable to battery terminal. Tighten fastener to 60-96 **in-lbs** (6.8-10.9 Nm).
14. Install seat. See [2.29 SEAT](#).

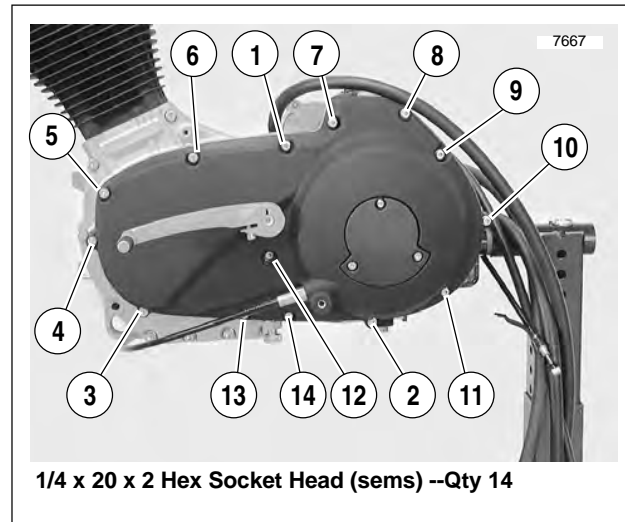

Figure 6-7. Primary Cover Tightening Sequence

GENERAL

Drive belt tension is not adjustable. Replace the belt and rear sprocket if either are worn or damaged.

Inspect the drive belt and rear sprocket:

- Replace every 15,000 mile (24,000 km) service interval.

NOTE

When a drive belt is replaced for any reason other than stone damage, it is recommended that the transmission and rear sprockets also be replaced to increase the longevity of the new drive belt. In the case of stone damage, inspect sprockets for damage and replace as required.

INSPECTION

Rear Sprocket

1. See [Figure 6-8](#). Inspect each tooth of rear sprocket for:
 - a. Major tooth damage.
 - b. Gouges caused by hard objects.
2. Replace rear sprocket if major tooth damage exists.

Drive Belt

See [Figure 6-9](#). Inspect drive belt for:

- Cuts or unusual wear patterns.
- Outside edge bevelling (8). Some bevelling is common, but it indicates that sprockets are misaligned.
- Outside ribbed surface for signs of stone puncture (7). If cracks/damage exists near edge of belt, replace belt immediately. Damage to center of belt will require belt replacement eventually, but when cracks extend to edge of belt, belt failure is imminent.
- Inside (toothed portion) of belt for exposed tensile cords (normally covered by nylon layer and polyethylene layer). This condition will result in belt failure and indicates worn transmission sprocket teeth. Replace belt and transmission sprocket.
- Signs of puncture or cracking at the base of the belt teeth. Replace belt if either condition exists.
- Replace belt if conditions 2, 3, 6 or 7 (on edge of belt) exist.

NOTE

Condition 1 may develop into 2 or 3 over time. Condition 1 is not grounds for replacing the belt, but it should be watched closely before condition 2 develops which will require belt replacement.

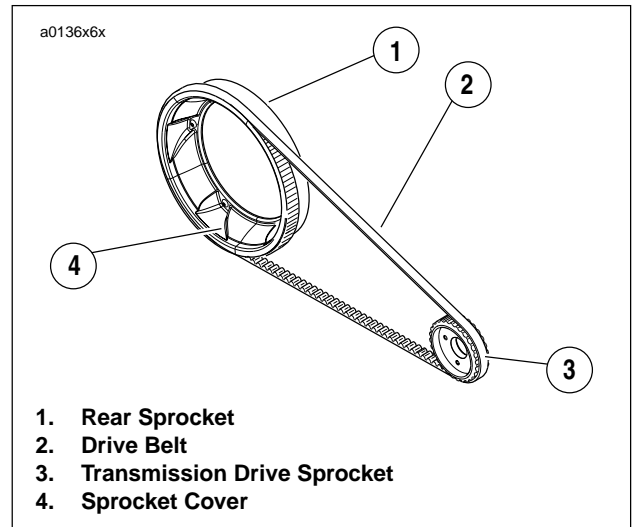

Figure 6-8. Secondary Drive Belt Assembly

a0147x6x

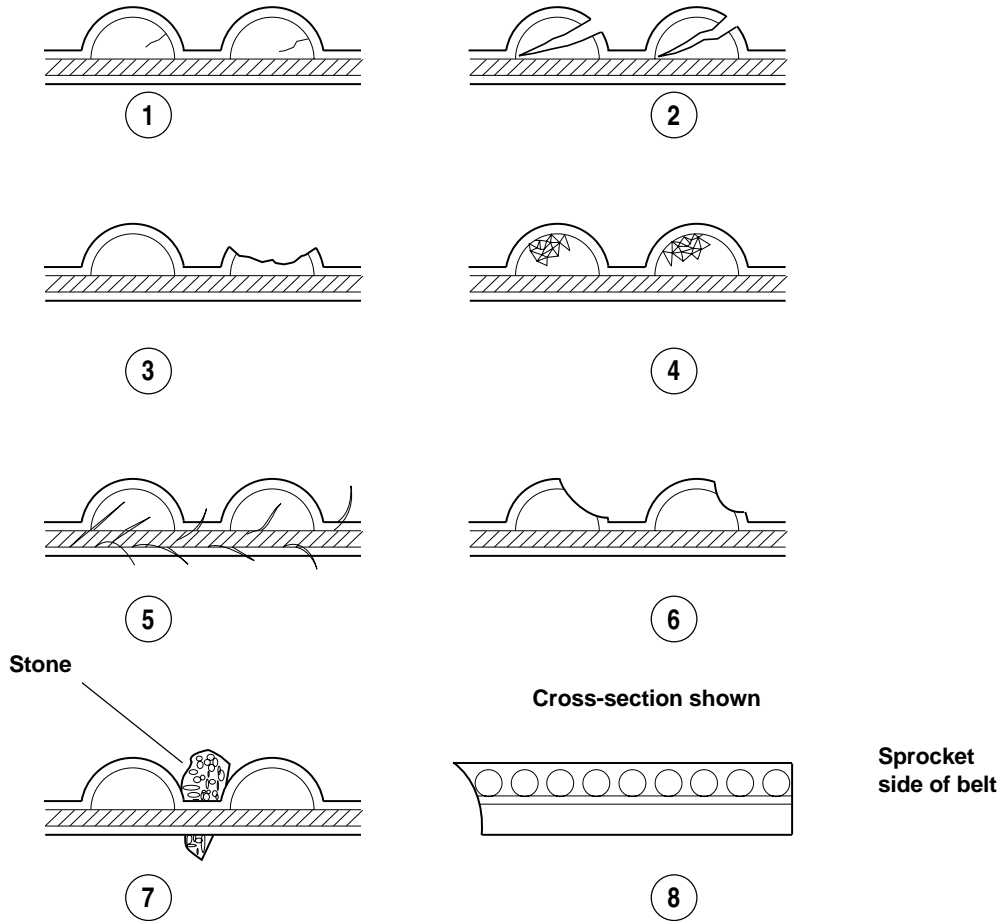

Figure 6-9. Drive Belt Wear Patterns

PATTERN IN FIGURE 6-9.	CONDITION	REQUIRED ACTION
1	Internal tooth cracks (hairline)	OK to run, but monitor condition
2	External tooth cracks	Replace belt
3	Missing teeth	Replace belt
4	Chipping (not serious)	OK to run, but monitor condition
5	Fuzzy edge cord	OK to run, but monitor condition
6	Hook wear	Replace belt
7	Stone damage	Replace belt if damage is on the edge
8	Bevel wear (outboard edge only)	OK to run, but monitor condition

REMOVAL

NOTE

Usually the rear sprocket is replaced whenever the drive belt is replaced. This procedure covers drive belt replacement only. For instructions on replacing both drive belt and rear sprocket, see 1.11 DRIVE BELT AND REAR SPROCKET.

1. Secure motorcycle on suitable lift that secures the front wheel.
2. Remove seat. See 2.29 SEAT.

WARNING

To protect against shock and accidental start-up of vehicle, disconnect the negative battery cable before proceeding. Inadequate safety precautions could result in death or serious injury.

3. Disconnect the negative battery cable from the battery.
4. Raise rear wheel off floor using REAR WHEEL SUPPORT STAND (Part No. B-41174).
5. See Figure 6-10. Place rod or screwdriver through axle hole. Loosen rear axle nut (metric).
6. Remove nut, lockwasher, and flat washer.
7. Pull axle out. Remove right side spacer.
8. Slide carrier with caliper off rotor.
9. Remove left side spacer.
10. Move wheel forward, disengage drive belt and remove rear wheel from motorcycle.
11. Remove rear brake master cylinder from right side footrest support. See 2.14 REAR BRAKE MASTER CYLINDER.
12. Remove right footrest support. See 2.22 FOOTPEGS AND FOOTPEG SUPPORT BRACKETS.
13. Remove three TORX bolts, washers and front sprocket cover from right side of motorcycle.
14. Remove two TORX screws and washers from right side of rear inner fender.
15. Carefully bend rear inner fender upwards and remove drive belt. Discard drive belt.

INSTALLATION

1. Install a **new** drive belt over transmission drive sprocket.
2. Install rear inner fender with two TORX screws and washers. See 2.24 FENDERS.
3. Install front sprocket cover with three TORX screws and washers.
4. Install right footrest support. See 2.22 FOOTPEGS AND FOOTPEG SUPPORT BRACKETS.
5. Install rear master cylinder. See 2.14 REAR BRAKE MASTER CYLINDER.
6. Position wheel in mounting position. Slide axle through washer, swing arm, carrier, left side spacer and wheel assembly. Position drive belt inboard of sprocket.
 - a. Hold right side spacer in place.
 - b. Insert axle through right side spacer and swingarm.
 - c. Install flat washer, lockwasher and axle nut.

7. Place screwdriver or rod through axle hole and tighten rear axle nut to 48-52 ft-lbs (65.1-70.5 Nm).
8. Slide belt on sprocket teeth by rotating rear wheel to "walk" belt onto teeth.
9. Lower motorcycle rear wheel.
10. Connect battery negative cable to battery terminal. Tighten fastener to 60-96 **in-lbs** (6.8-10.9 Nm).

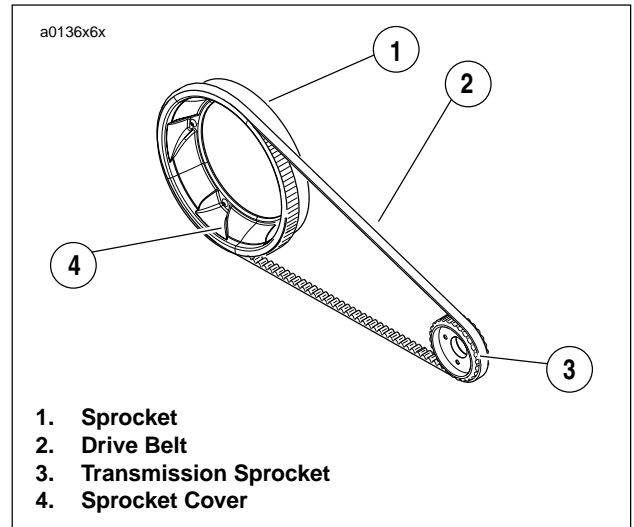

Figure 6-10. Secondary Drive Belt Assembly

TRANSMISSION FLUID

Drain and refill with fresh transmission fluid:

- At the 1000 mile (1600 km) initial service interval and at every 5000 mile (8000 km) service interval thereafter.

Transmission fluid capacity is 1.0 quart (0.95 liter). For best results, drain fluid while it is hot.

- Raise rear wheel off floor using REAR WHEEL SUPPORT STAND (Part No. B-41174). This prevents transmission fluid from spilling out of the clutch inspection cover opening.
- See [Figure 6-11](#). Position a suitable container under drain plug (3). Remove plug and drain fluid.
- Wipe any foreign material from the magnetic drain plug (3). Reinstall plug. Tighten to 14-30 ft-lbs (19.0-54 Nm).
- Remove seat. See [2.29 SEAT](#).

WARNING

To avoid accidental start-up of vehicle and possible personal injury, disconnect the battery cables before proceeding. Inadequate safety precautions could result in death or serious injury.

- Disconnect negative battery cable from battery.
- Remove left footpeg support bracket. See [2.22 FOOTPEGS AND FOOTPEG SUPPORT BRACKETS](#).
- Remove three TORX screws with washers (1) from clutch inspection cover (2). Remove clutch inspection cover from primary cover.

CAUTION

Do not overfill the primary chaincase with lubricant. Overfilling may cause rough clutch engagement, incomplete disengagement, clutch drag and/or difficulty in finding neutral at engine idle.

- See [Figure 6-12](#). Add SPORT-TRANS FLUID (Part No. 98854-96 quart size; Part No. 98855-96 gallon size) as required until fluid level is even with bottom of clutch diaphragm spring.
- See [Figure 6-11](#). Install clutch inspection cover and new gasket with three TORX screws with washers. Tighten in a crosswise pattern to 7-9 ft-lbs (9.5-12.2 Nm).
- Install left footpeg support bracket. See [2.22 FOOTPEGS AND FOOTPEG SUPPORT BRACKETS](#).
- Connect negative battery cable to battery. Tighten fastener to 60-96 in-lbs (6.8-10.9 Nm).
- Install seat. See [2.29 SEAT](#).

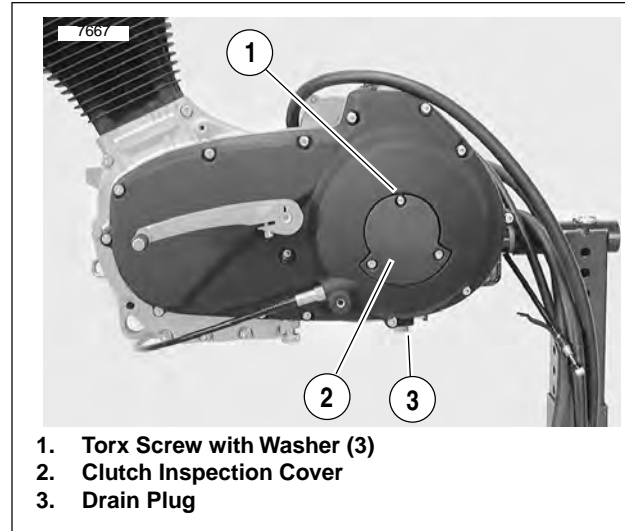

Figure 6-11. Primary Cover

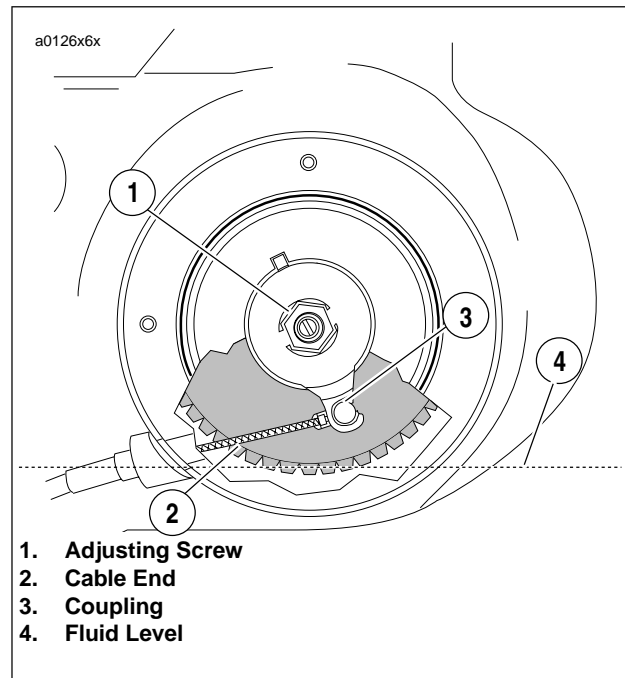

Figure 6-12. Fluid Level

ADJUSTMENT

Check clutch adjustment:

- At the 1000 mile (800 km) service interval.
- At every 5000 mile (8000 km) service interval thereafter.

If clutch slips under load or drags when released, first check control cable adjustment. If cable adjustment is within specifications, adjust clutch mechanism as described below.

When necessary, lubricate cable with LUBIT-8 TUFOIL® CHAIN AND CABLE LUBE (Part No. HD-94968-85TV).

1. Raise rear wheel off floor using REAR WHEEL SUPPORT STAND (Part No. B-41174).
2. Remove left footpeg support bracket. See 2.22 FOOTPEGS AND FOOTPEG SUPPORT BRACKETS.
3. See Figure 6-13. Slide rubber boot (1) upward to expose adjuster mechanism. Loosen jam nut (3) from adjuster (4).
4. See Figure 6-14. Remove three TORX screws with washers (1) from clutch inspection cover (2). Remove clutch inspection cover from primary cover.

NOTE

Quad ring removed from primary cover for illustrative purposes only in Figure 6-14.

5. Remove spring (4) and lockplate (5). Turn adjusting screw (6) counterclockwise until it lightly bottoms.
6. Turn adjusting screw (6) clockwise 1/4 turn. Install lockplate (5) and spring (4) on adjusting screw flats. If hex on lockplate does not align with recess in outer ramp, rotate adjusting screw clockwise until it aligns.
7. Squeeze clutch hand lever to maximum limit three times. This sets the ball and ramp mechanism. Pull outer cable conduit and at the same time adjust cable adjuster to provide 0.0625-0.125 in. (1.6-3.2 mm) freeplay at clutch hand lever. Adjust as follows.
 - a. See Figure 6-15. Pull ferrule (1) (end of cable housing) away from bracket (2). Gap between ferrule and bracket should be 0.0625-0.125 in. (1.6-3.2 mm).
 - b. See Figure 6-13. Set freeplay by turning adjuster (4).
 - c. Tighten jam nut (3) against adjuster (4).
 - d. Slide boot (1) over cable adjuster mechanism.
8. Change or add transmission fluid if necessary.

NOTE

Clean parts before re-assembly.

9. See Figure 6-14. Install clutch inspection cover and new gasket with three TORX screws with washers. Tighten in a crosswise pattern to 7-9 ft-lbs (9.5-12.2 Nm).
10. Check clutch cable freeplay. See Step 6 above.
11. Install footpeg support bracket. See 2.22 FOOTPEGS AND FOOTPEG SUPPORT BRACKETS.

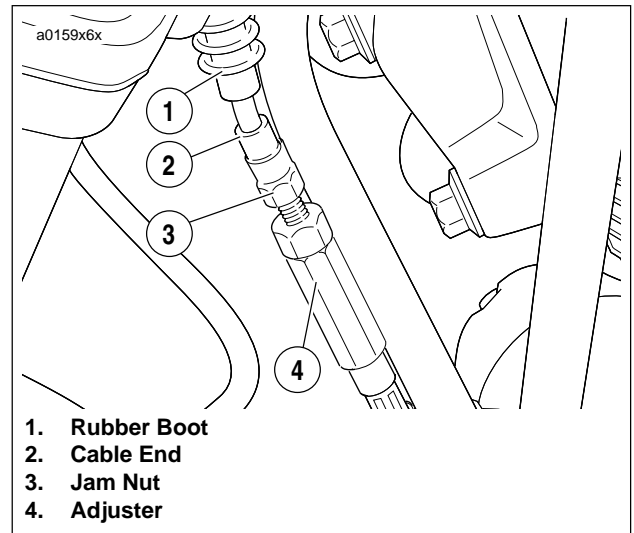

Figure 6-13. Clutch Cable Adjuster Mechanism

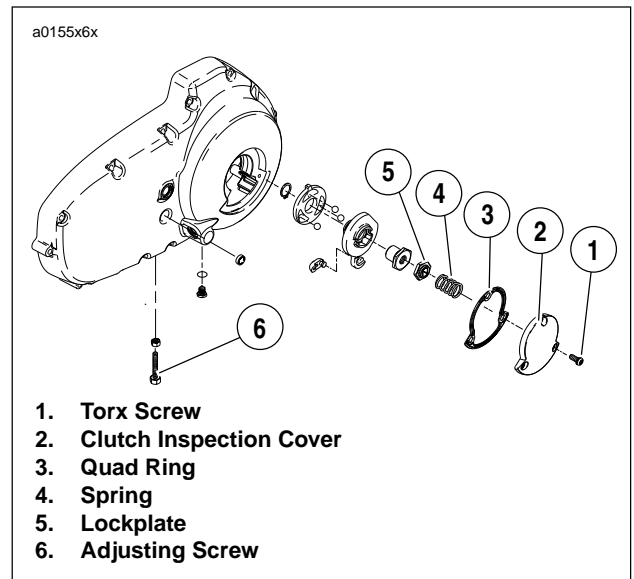

Figure 6-14. Clutch Release Mechanism

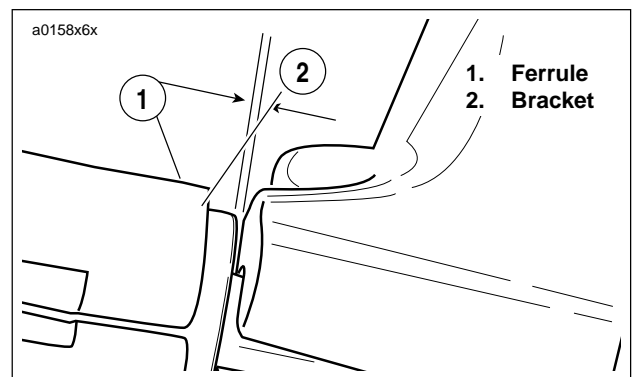

Figure 6-15. Adjusting Clutch Freeplay

NOTE

For clutch adjustment procedure, See 6.4 CLUTCH.

DISASSEMBLY

1. Remove seat. See 2.29 SEAT.

 **WARNING**

To protect against shock and accidental start-up of vehicle, disconnect the negative battery cable before proceeding. Inadequate safety precautions could result in death or serious injury.

2. Disconnect negative battery cable.
3. Pull clutch cable ferrule (end of cable housing) away from clutch hand lever bracket. Gap between ferrule and bracket should be 0.0625-0.125 (1.6-3.2 mm). Adjust freeplay by turning cable adjuster.
4. Remove left footpeg support bracket. See 2.22 FOOTPEGS AND FOOTPEG SUPPORT BRACKETS.
5. See Figure 6-16. Remove three TORX screws with washers and clutch inspection cover.

6. Slide spring with attached screw lockplate from flats of adjusting screw.
7. Turn adjusting screw clockwise to release ramp and coupling mechanism. As the adjusting screw is turned, ramp assembly moves forward. Unscrew nut from end of adjusting screw.

CLEANING AND INSPECTION

1. Thoroughly clean all parts in cleaning solvent.
2. See Figure 6-16. Inspect three balls of release mechanism and ball socket surfaces of inner and outer ramps for wear, pitting, surface breakdown and other damage. Replace parts as necessary.
3. Check hub fit of inner and outer ramps. Replace ramps if excessively worn.
4. Check clutch cable for frayed or worn ends. Replace cable if damaged or worn.
5. Change or add transmission fluid if necessary. See 6.4 CLUTCH.

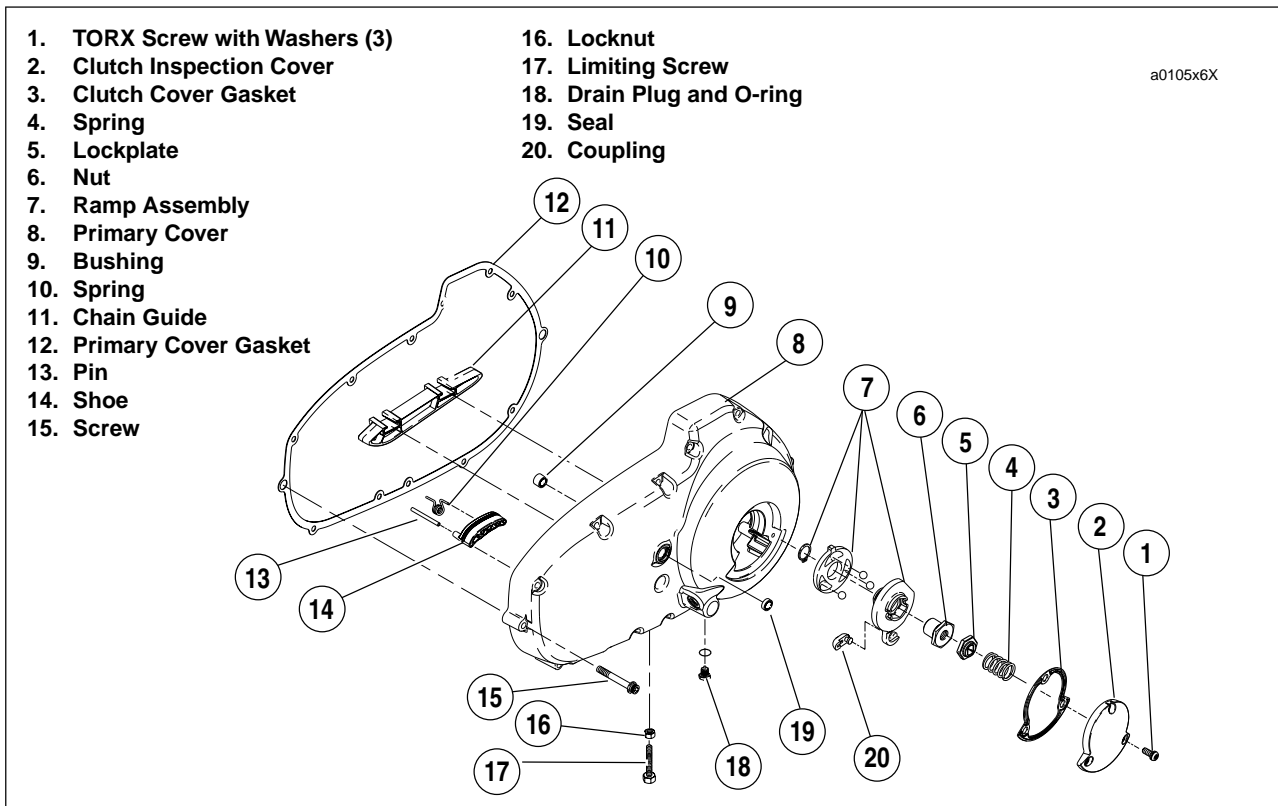

Figure 6-16. Clutch Release Mechanism

ASSEMBLY

1. See [Figure 6-17](#). Assemble inner and outer ramp.
 - a. Apply multi-purpose grease to balls and ramps.
 - b. Insert balls in sockets of outer ramp.
 - c. Install inner ramp on hub of outer ramp with tang 180° from hook of outer ramp.
 - d. Install **new** retaining ring in groove of outer ramp hub.
2. See [Figure 6-18](#). Install ramp assembly.
 - a. Fit coupling over cable end with rounded side inboard, the ramp connector button outboard.
 - b. With retaining ring side of ramp assembly facing inward, place hook of ramp around coupling button.
 - c. Rotate assembly counterclockwise until tang on inner ramp fits in slot of primary cover.
3. Secure assembly in place.
 - a. Thread nut on adjusting screw until slot of screw is accessible with a screwdriver.
 - b. Turn adjusting screw counterclockwise until resistance is felt.
 - c. Adjust clutch release mechanism. See [6.4 CLUTCH](#).
 - d. Fit nut hex into recess of outer ramp.

WARNING

Always connect positive battery cable first. If the positive cable should contact ground with the negative cable installed, the resulting sparks may cause a battery explosion which could result in death or serious injury.

4. Install left footpeg support bracket. See [2.22 FOOTPEGS AND FOOTPEG SUPPORT BRACKETS](#).
5. Connect negative battery cable to battery terminal. Tighten fastener to 60-96 **in-lbs** (6.8-10.9 Nm).
6. Install seat. See [2.29 SEAT](#).

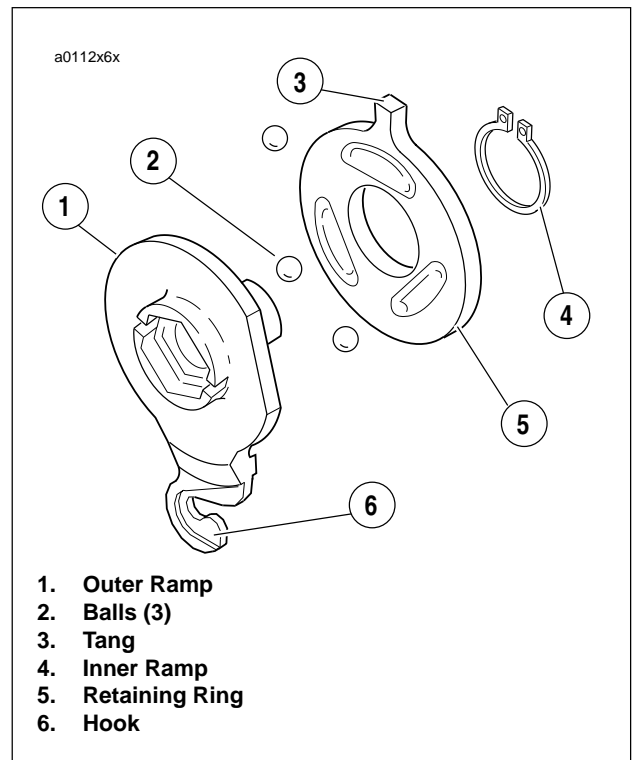

Figure 6-17. Inner & Outer Ramp

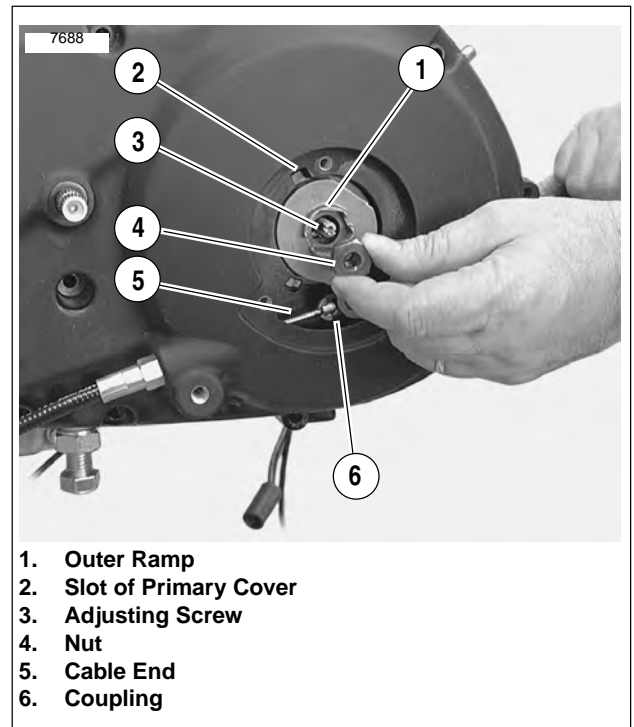

Figure 6-18. Nut & Outer Ramp

GENERAL

The purpose of the clutch is to smoothly disengage and engage the engine from the rear wheel for starting, stopping and shifting gears.

See [Figure 6-19](#). The clutch is a wet, multiple-disc clutch with five steel plates and five fiber (friction) plates stacked alternately in the clutch shell. The order of plate assembly, from inboard to outboard, is as follows:

St - F - St - F - St - F - St - F - St - F

(St = Steel plate, F = Fiber plate)

The fiber plates (clutch driving plates) are keyed to the clutch shell, which is driven by the engine through the primary chain. The steel plates (clutch driven plates) and the centrally located spring plate (also a clutch driven plate) are keyed to the clutch hub, which drives the rear wheel through the transmission and secondary drive belt.

When the clutch is engaged (clutch lever released), the diaphragm spring applies strong inward force against the pressure plate. The pressure plate then presses the clutch plates together, allowing no slippage between the plates and causing the plates to turn as a single unit. The result is that the rotational force of the clutch shell is fully transmitted through the “locked” clutch plates to the clutch hub. As long as the transmission is set in a forward gear, power from the engine will be transmitted to the rear wheel.

When the clutch is disengaged (clutch lever pulled to left handlebar grip), the pressure plate is pulled outward (by clutch cable action) against the diaphragm spring, thereby compressing the diaphragm spring. With the pressure plate retracted, strong inward force no longer squeezes the clutch plates together. The fiber plates are now free to rotate at a different relative speed than that of the steel and spring plates (i.e. – Slippage between the clutch plates occurs). The result is that the rotational force of the clutch shell is no longer fully transmitted through the “unlocked” clutch plates to the clutch hub. The engine is free to rotate at a different speed than the rear wheel.

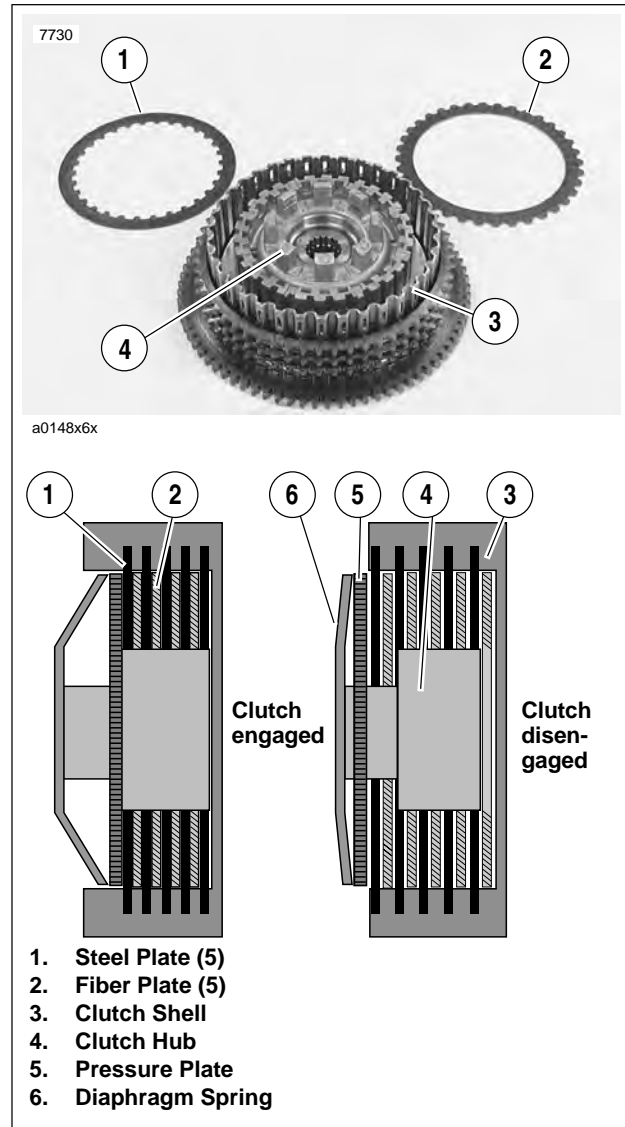

Figure 6-19. Clutch Plates and Hub/Shell Assembly

SYMPTOM	CAUSE (CHECK IN FOLLOWING ORDER)	REMEDY
Clutch slips.	Incorrect clutch release adjustment. Worn clutch plates.	Check and adjust clutch release mechanism. Check service wear limits. Replace plates.
Clutch drags.	Incorrect clutch release adjustment. Worn clutch release ramps or balls. Warped clutch steel plates. Blade worn or damaged clutch gear splines. Overfilled primary.	Check and adjust clutch release mechanism. Replace release ramps and/or balls. Replace clutch steel plates. Replace clutch gear or hub as required. Drain lubricant to correct level.

REMOVAL/DISASSEMBLY

Clutch Pack

WARNING

To protect against shock and accidental start-up of vehicle, disconnect the negative battery cable before proceeding. Inadequate safety precautions could result in death or serious injury.

1. Remove primary cover. See 6.2 PRIMARY CHAIN.

WARNING

Do not attempt to disassemble the clutch without **SPRING COMPRESSING TOOL** (Part No. HD-38515-A), **CLUTCH SPRING FORCING SCREW** (Part No. HD-38515-91) and proper eye protection. Otherwise, the highly compressed diaphragm spring could fly out with great force which could result in death or serious injury.

2. See Figure 6-20. Attach tools to compress clutch diaphragm spring.
 - a. Thread the CLUTCH SPRING FORCING SCREW (Part No. HD-38515-91) onto the clutch adjusting screw.
 - b. Place the bridge of SPRING COMPRESSING TOOL (Part No. HD-38515-A) against diaphragm spring.
 - c. Install bearing and washer.
 - d. Thread the tool handle onto end of forcing screw.

CAUTION

See Figure 6-21. Turn compressing tool handle only the amount required to release spring seat and remove snap ring. Excessive compression of diaphragm spring could damage clutch pressure plate.

3. Remove pressure plate assembly.
 - a. Place a wrench on the clutch spring forcing screw flats to prevent the forcing screw from turning.
 - b. Turn compressing tool handle clockwise until tool relieves pressure on snap ring and spring seat. Remove and discard snap ring.
 - c. Unseat spring seat from the groove in clutch hub prongs.
 - d. Remove pressure plate assembly.
4. See Figure 6-23. Remove the clutch pack from the hub/shell assembly. The pack consists of five fiber plates and five steel plates.

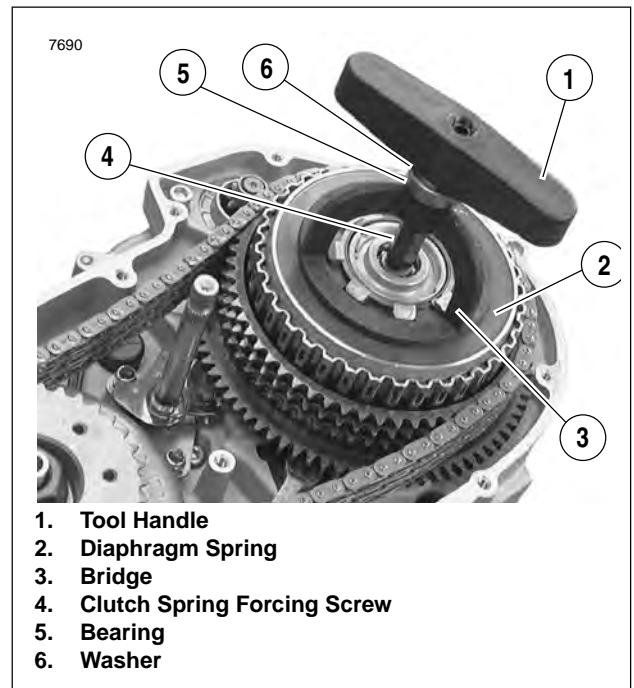
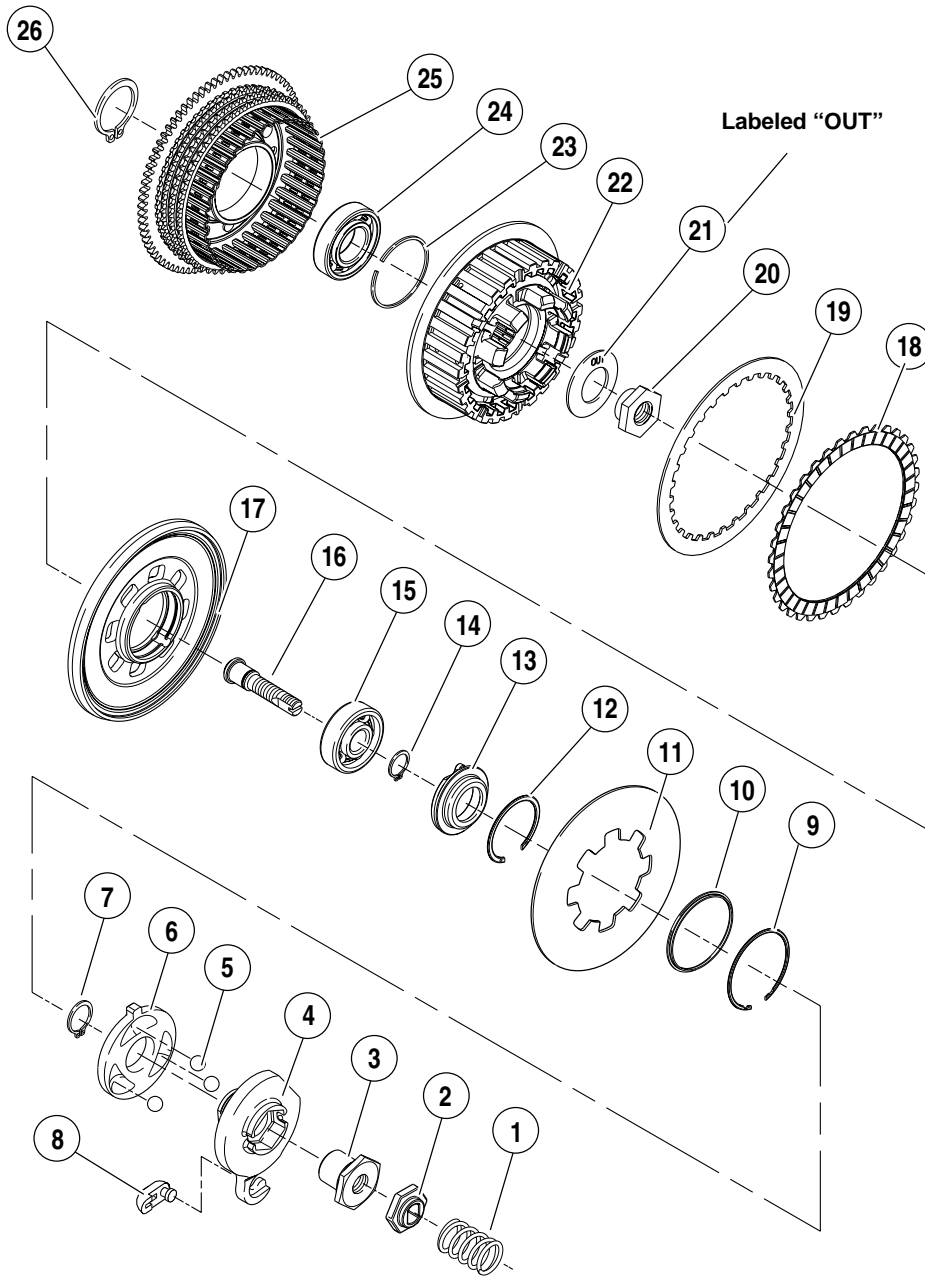

Figure 6-20. Compressing Clutch Diagram Spring



Figure 6-21. Pressure Plate Assembly

a0114x6x



1. Spring
2. Lockplate
3. Nut
4. Outer Ramp
5. Ball (3)
6. Inner Ramp
7. Retaining Ring
8. Coupling
9. Retaining Ring
10. Spring Seat
11. Diaphragm Spring
12. Retaining Ring
13. Release Plate
14. Retaining Ring
15. Bearing

16. Adjusting Screw
17. Pressure Plate
18. Friction Plate (paper) (5)
19. Steel Plate (5)
20. Mainshaft Nut
21. Washer
22. Clutch Hub
23. Retaining Ring
24. Bearing
25. Clutch Shell and Sprocket
26. Retaining Ring

Figure 6-22. Clutch Assembly

Primary Chain/Drive

WARNING

To protect against shock and accidental start-up of vehicle, disconnect the negative battery cable before proceeding. Inadequate safety precautions could result in death or serious injury.

1. Remove negative battery cable from battery.
2. Remove primary cover. See 6.2 PRIMARY CHAIN.
3. Loosen engine sprocket.
 - a. Install SPROCKET LOCKING LINK (Part No. HD-38362).
 - b. Remove the engine sprocket nut.
 - c. Loosen, but do not remove, engine sprocket. If necessary, use the slotted portion of TWO CLAW PULLER (Part No. HD-97292-61) and two bolts to loosen the engine sprocket.
4. See Figure 6-23. Remove adjusting screw assembly.
 - a. Remove large retaining ring.
 - b. Remove adjusting screw assembly from pressure plate.

CAUTION

See Figure 6-24. Mainshaft nut has left-hand threads. To prevent damage, turn nut clockwise to loosen and remove from mainshaft.

5. Remove mainshaft nut and washer.
6. Remove the clutch assembly, primary chain and engine sprocket as a unit.
 - a. Inspect primary chain and sprockets for damage or excessive wear.
 - b. Inspect stator and rotor. See 7.14 ALTERNATOR.
 - c. Replace damaged parts as necessary.
7. Install adjusting screw assembly into pressure plate.
 - a. See Figure 6-24. Align two tabs on perimeter of release plate with corresponding recesses in pressure plate.
 - b. See Figure 6-23. Secure the adjusting screw assembly with large retaining ring.
8. Attach tools to compress clutch diaphragm spring. See Step 2 of CLUTCH PACK under 6.6 PRIMARY DRIVE/CLUTCH.
9. Remove clutch pack components. See Steps 3-4 of CLUTCH PACK under 6.6 PRIMARY DRIVE/CLUTCH.

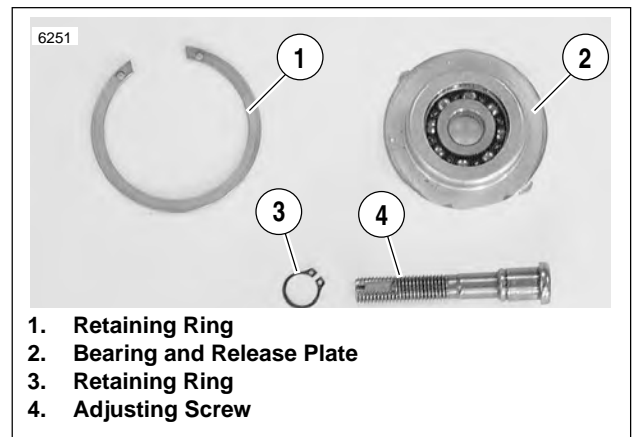

Figure 6-23. Adjusting Screw Assembly

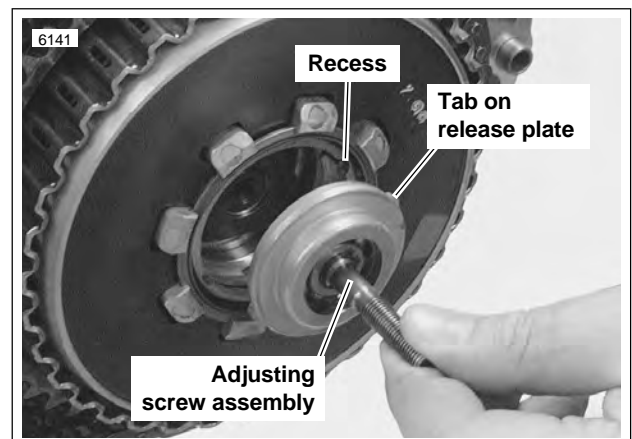

Figure 6-24. Aligning Tabs

10. See Figure 6-21. Disassemble pressure plate.
 - a. Place a wrench on the clutch spring forcing screw flats to prevent the forcing screw from turning.
 - b. Turn the compressing tool handle counterclockwise until the handle spins off.
 - c. Remove washer, bearing and bridge.
 - d. Remove clutch spring forcing screw from clutch adjusting screw.
 - e. Remove spring seat and diaphragm spring from pressure plate.
11. See Figure 6-23. Remove and disassemble adjusting screw assembly.
 - a. Remove large retaining ring.
 - b. Remove adjusting screw assembly from pressure plate.
 - c. If necessary, disassemble adjusting screw assembly. Remove and discard small retaining ring and then separate the adjusting screw from the bearing and release plate. Remove bearing from release plate.

CAUTION

See **Figure 6-22**. To prevent possible damage to the bearing, the clutch hub and shell assembly should not be disassembled unless the bearing, hub or shell require replacement. If the assembly is pressed apart, the bearing must be replaced.

12. Disassemble clutch hub and clutch shell if necessary.
 - a. Remove retaining ring from inboard end of clutch hub.
 - b. Using an arbor press, separate clutch hub from assembly of clutch shell, bearing and retaining ring.
 - c. Remove retaining ring from groove in clutch shell.
 - d. Press on the inboard side of bearing outer race to remove bearing from clutch shell.

INSPECTION

1. Wash all parts, except fiber (friction) plates and bearing, in cleaning solvent. Blow dry with compressed air. Examine the clutch components as follows:
 - a. Check all clutch plates for wear and discoloration.
 - b. Inspect each steel (drive) plate for grooves.
 - c. Place each steel plate on a flat surface. Using a feeler gauge, check for flatness in several places. Replace any plates that are damaged or are warped more than 0.006 in. (0.152 mm).
2. Check the diaphragm spring for cracks or bent tabs. Install a **new** spring if either condition exists.
3. See **Figure 6-25**. Check fiber plates for thickness.
 - a. Wipe the lubricant from the five fiber plates and stack them on top of each other.
 - b. Measure the thickness of the five stacked fiber plates with a dial caliper or micrometer. The minimum thickness must be 0.413 in. (10.490 mm).
 - c. If the thickness is less than specified, discard the fiber plates and steel plates. Install a **new** set of both friction and steel plates.
4. See **Figure 6-26**. Check the clutch shell.
 - a. Inspect primary chain sprocket and the starter ring gear on the clutch shell. If either sprocket or ring gear are badly worn or damaged, replace the clutch shell.
 - b. Check the slots that mate with the clutch plates on both clutch shell and hub. If slots are worn or damaged, replace shell and/or hub.
 - c. If clutch shell was removed from motorcycle, check the bearing for smoothness. Rotate the clutch shell while holding the clutch hub. If bearing is rough or binds, it must be replaced.



Figure 6-25. Measuring Friction Plates

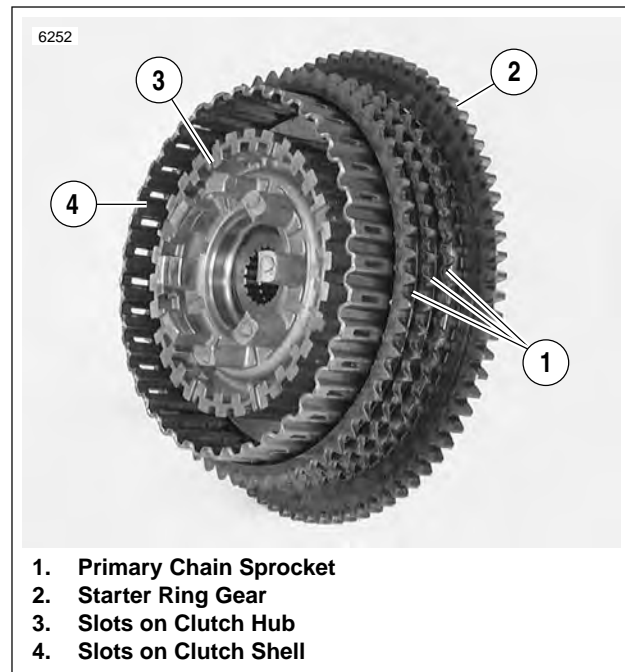

1. **Primary Chain Sprocket**
2. **Starter Ring Gear**
3. **Slots on Clutch Hub**
4. **Slots on Clutch Shell**

Figure 6-26. Checking Clutch Shell

ASSEMBLY

Clutch Pack

See [Figure 6-22](#). Install the clutch pack which consists of five fiber plates and five steel plates, into the clutch hub. The order of plate assembly, from inboard to outboard, is as follows:

St - F - St - F - St - F - St - F - St - F

(St = Steel plate, F = Fiber plate)

CAUTION

See [Figure 6-21](#). Turn compressing tool handle **only** the amount required to install spring seat and snap ring. Excessive compression of diaphragm spring could damage clutch pressure plate.

5. Place assembly of spring seat, **new** snap ring, diaphragm spring, pressure plate, adjusting screw components and compressing tool onto clutch hub and against clutch pack.
 - a. See [Figure 6-27](#). Align square openings of pressure plate and diaphragm spring so that the assembly can be installed over prongs of clutch hub.
 - b. Position spring seat with its larger O.D. side toward diaphragm spring.
 - c. See [Figure 6-28](#). Place a wrench on the clutch spring forcing screw flats to prevent the forcing screw from turning.
 - d. Turn compressing tool handle clockwise until diaphragm spring compresses just enough to install spring seat and **new** snap ring into the groove in clutch hub prongs.
 - e. With snap ring positioned against outboard side of spring seat, and fully seated in groove of clutch hub, carefully loosen and remove compression tool.

Primary Drive

1. See [Figure 6-28](#). Assemble clutch hub and shell if necessary.
 - a. Press **new** bearing in clutch shell. Secure bearing with a **new** retaining ring.
 - b. Press inboard end of clutch hub into shell bearing. Secure with **new** retaining ring on end of hub.
2. Assemble pressure plate hardware.
 - a. See [Figure 6-23](#). Place bearing inside release plate. Insert adjusting screw through bearing and release plate. Secure with **new** retaining ring.
 - b. See [Figure 6-27](#). Position diaphragm spring with its concave side facing toward pressure plate onto pressure plate assembly.
 - c. Insert adjusting screw assembly into pressure plate. Secure with large retaining ring.
 - d. Position spring seat with its larger O.D. side toward diaphragm spring.
3. Attach tools to compress clutch diaphragm spring. Do not tighten compressing tool against diaphragm spring at this time. See Step 2 of [CLUTCH PACK](#) under 6.6 PRIMARY DRIVE/CLUTCH.
4. Install the clutch pack. Follow all instructions of [CLUTCH PACK](#) under 6.6 PRIMARY DRIVE/CLUTCH.

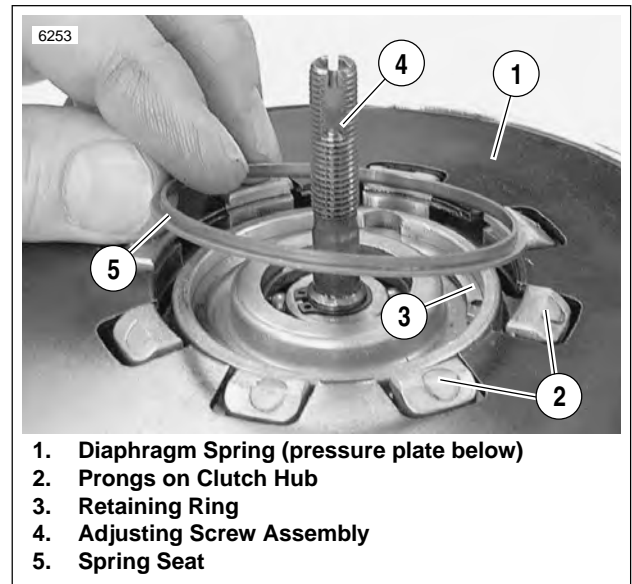

Figure 6-27. Spring Seat Installation

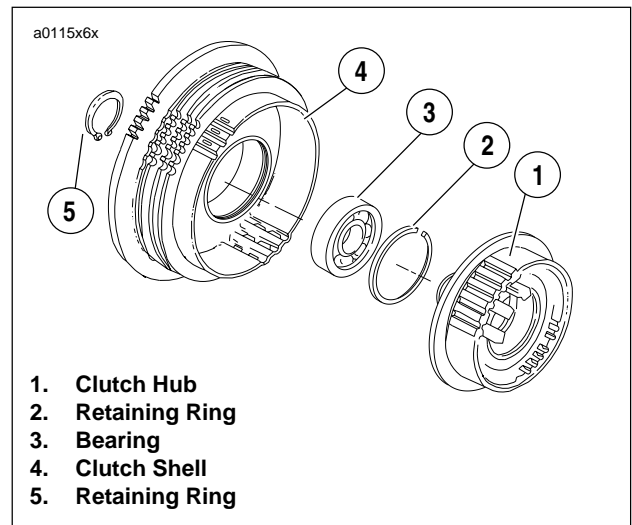

Figure 6-28. Clutch Hub and Shell Assembly

INSTALLATION

NOTE

If clutch pack replacement was the only service work performed, start with Step 5.

1. Install the engine sprocket, clutch assembly and primary chain as a unit into primary chaincase.
2. See Figure 6-29. Install the engine sprocket nut.
 - a. Place SPROCKET LOCKING LINK (Part No. HD-38362) between primary chain and engine sprocket.
 - b. Apply two or three drops of LOCTITE® thread locker 262 (red) onto threads of sprocket shaft.
 - c. Install engine sprocket nut. Tighten to 190-210 ft-lbs (257.6-284.7 Nm).

CAUTION

See Figure 6-30. Washer must be installed with the word "out" facing the mainshaft nut or transmission may be damaged.

3. Install mainshaft nut and washer.
 - a. Apply two or three drops of LOCTITE® thread locker 262 (red) onto threads on end of mainshaft.
 - b. Place washer on mainshaft with the word "out" facing away from clutch hub.
 - c. Install nut (**left-hand threads**). Tighten to 70-80 ft-lbs (94.9-108.5 Nm).
4. Remove SPROCKET LOCKING LINK.
5. Install adjusting screw assembly into pressure plate.
 - a. See Figure 6-24. Align two tabs on perimeter of release plate with corresponding recesses in pressure plate.
 - b. See Figure 6-23. Secure the adjusting screw assembly with retaining ring.
6. Install primary cover. See 6.2 PRIMARY CHAIN.
7. Install left footpeg support bracket. See 2.22 FOOTPEGS AND FOOTPEG SUPPORT BRACKETS.
8. Connect negative battery cable to battery terminal. Tighten fastener to 60-96 **in-lbs** (6.8-10.9 Nm).
9. Install seat. See 2.29 SEAT.

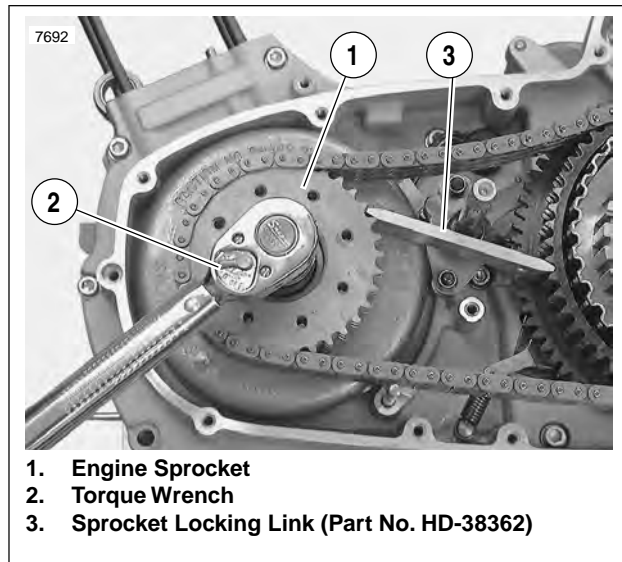

Figure 6-29. Sprocket Locking Link

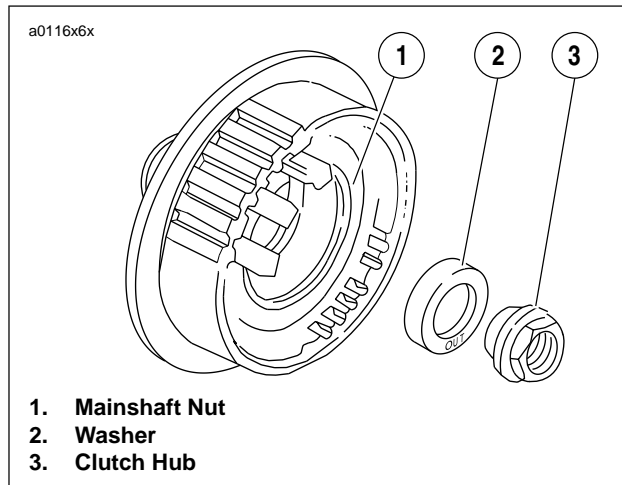

Figure 6-30. Mainshaft Nut and Washer

GENERAL

See Figure 6-31. The transmission is a five-speed constant-mesh type housed in an extension of the crankcase. The transmission permits the rider to vary the ratio of engine speed-to-rear driving wheel speed in order to meet the varying conditions of operation.

LUBRICATION

Drain transmission and refill to correct level with fresh, clean lubricant at least once each year or every 5000 miles (8000 km), whichever comes first. For best results, drain lubricant while hot. See 6.4 CLUTCH.

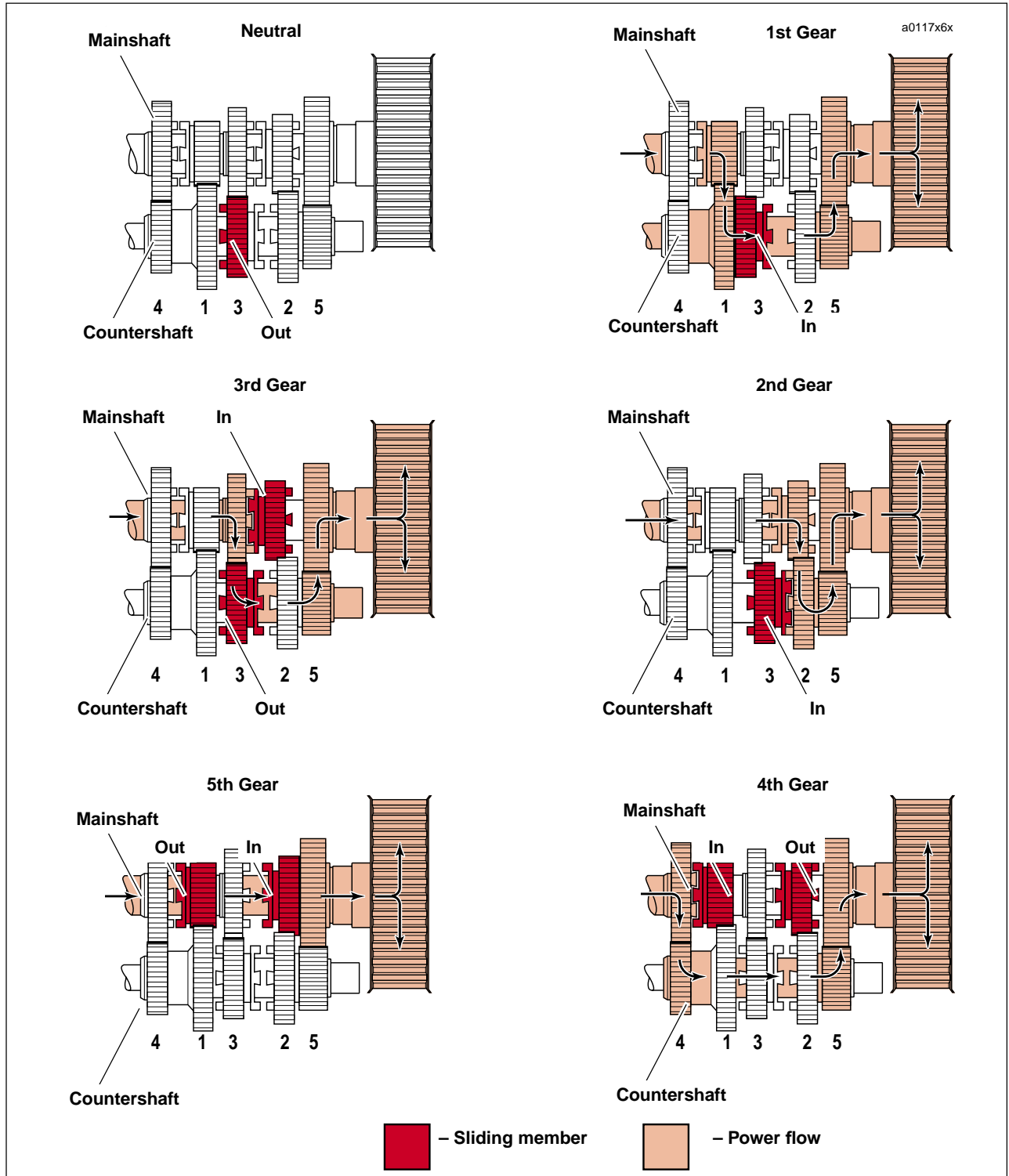

Figure 6-31. Transmission Power Flow

GENERAL

The rear compartment of the left and right crankcase halves form the transmission case. Servicing of transmission components requires removing the engine and disassembling (splitting) the crankcase.

REMOVAL

1. Remove transmission sprocket. See 6.16 TRANSMISSION SPROCKET.
2. Remove engine from chassis. See 3.3 STRIPPING MOTORCYCLE FOR ENGINE REPAIR/REMOVAL.
3. Support engine using ENGINE SUPPORT STAND (Part No. HD-42310/HD-43646 or HD-43682).
4. Disassemble top end. See 3.5 CYLINDER HEAD.
5. Disassemble gearcase. See 3.16 GEARCASE COVER AND CAM GEARS.
6. Remove primary cover. See 6.2 PRIMARY CHAIN.
7. Remove clutch assembly, primary chain and engine sprocket. See 6.6 PRIMARY DRIVE/CLUTCH.
8. See Figure 6-32. Place transmission in gear. Remove countershaft TORX screw (1) and retention collar (2).
9. See Figure 6-33. Detach spring (11) from groove in post.
10. Remove retaining ring (10) and detent plate (9). Discard retaining ring (10). You will need to use a **new** retaining ring for installation.
11. Remove starter. See 5.7 STARTER.
12. Remove two locknuts (2) and washers (3) which attach shifter shaft assembly (1) to studs at transmission case. Remove shifter shaft assembly (1).
13. Remove detent screw (8), detent arm (7) and spring (11).
14. See Figure 6-35. Remove all transmission case bolts.
15. See Figure 6-35. Remove rear motor mount (9) and mounting hardware (10,11).
16. See Figure 6-34. Separate crankcase halves.

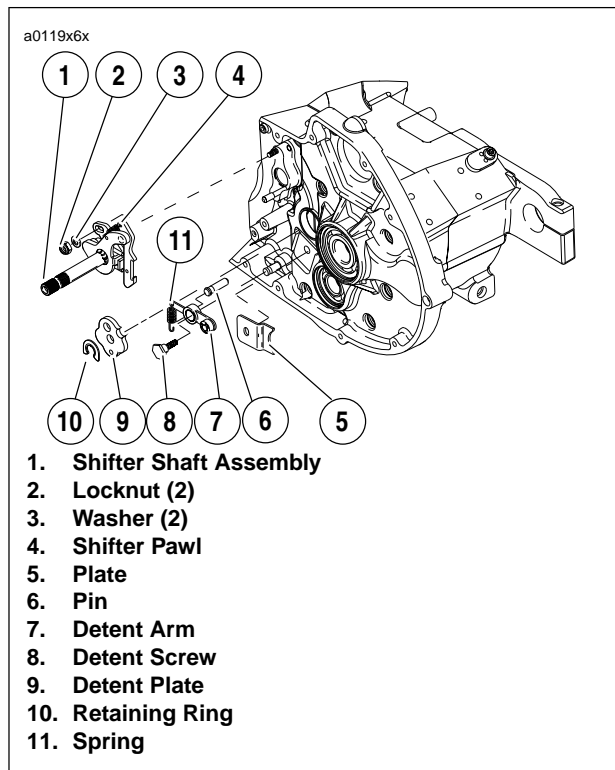

Figure 6-33. Shifter Shaft Assembly

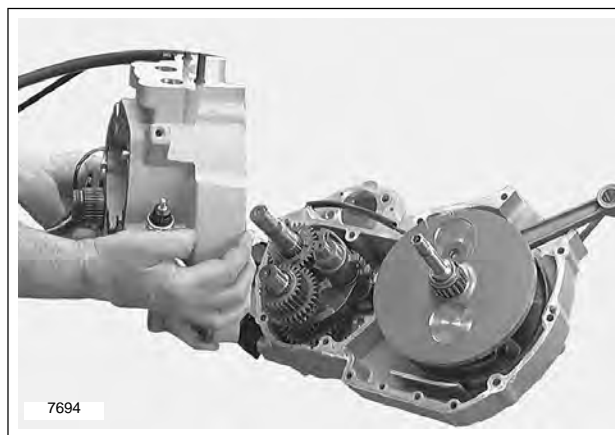

Figure 6-34. Splitting Crankcase Halves

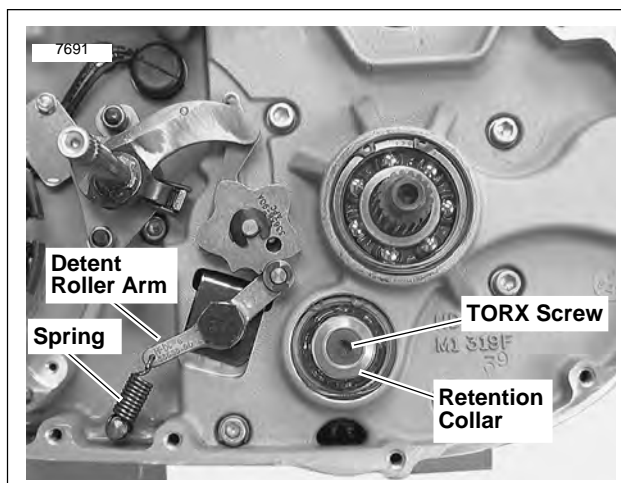
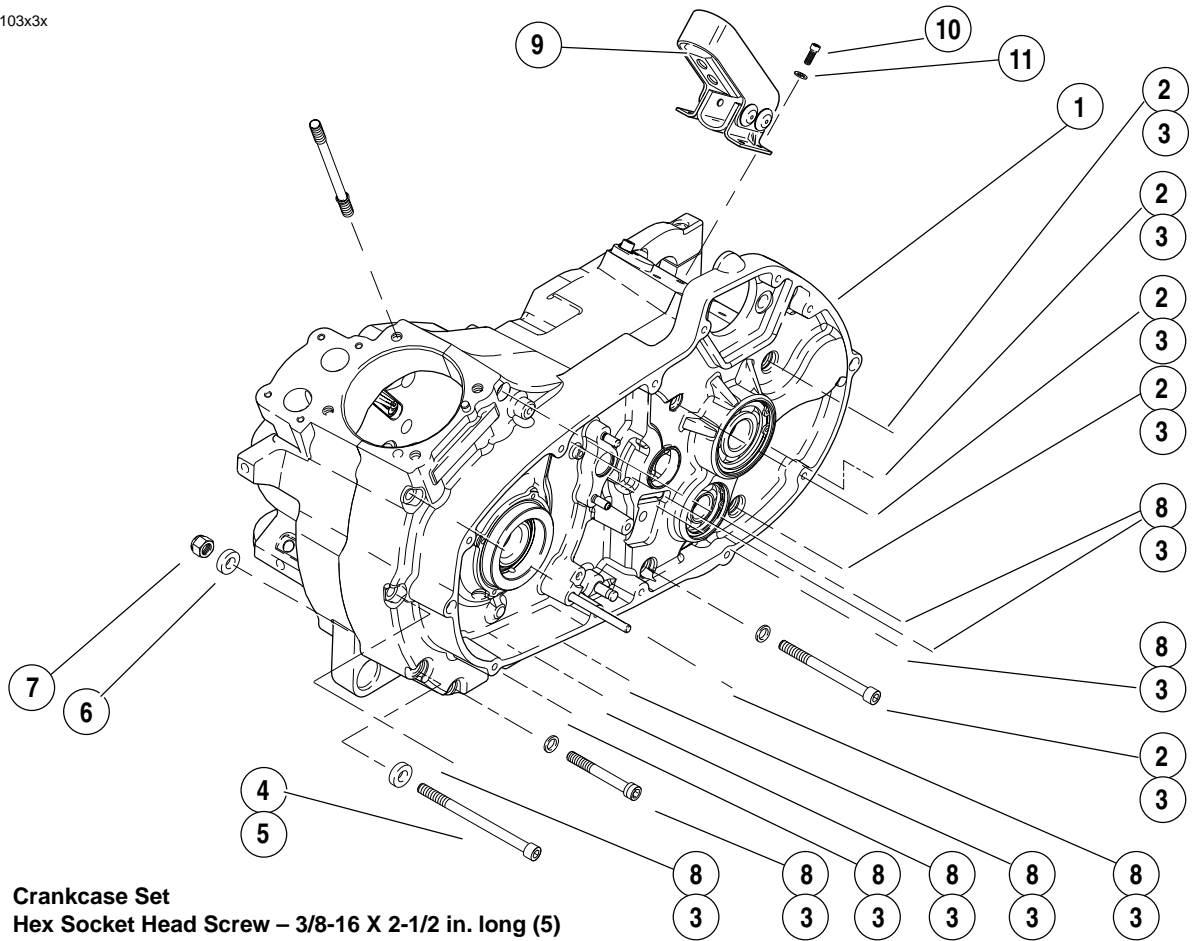

Figure 6-32. Countershaft Retainer

a0103x3x



1. Crankcase Set
2. Hex Socket Head Screw – 3/8-16 X 2-1/2 in. long (5)
3. Washer 21/64 x 9/16 x 19 (14)
4. Hex Socket Head Screw – 3/8-16 X 4-1/2 in. long (1)
5. Spacer (1)
6. Washer - 3/8 I.D. X 13/16 O.D. (1)
7. Nyloc, Hex Locknut - 3/8-16
8. Bottom Case T40 TORX Bolt – 5/16-18 X 3-1/2 in. long (9)
9. Rear Isolator
10. Screw (4)
11. Washer (4)

Figure 6-35. Crankcase Hardware

CASE REMOVAL

NOTES

- *If transmission only is being serviced, do not remove flywheel assembly.*
 - *For crankcase, flywheel or other major servicing, the flywheel assembly can be removed at any time. The same specialty tools are used.*
1. See [Figure 6-36](#). Remove transmission case. See [6.8 TRANSMISSION CASE](#)
 2. See [Figure 6-36](#). Split crankcases in half. See [6.8 TRANSMISSION CASE](#).
 3. Remove crankcase and transmission assembly from engine stand.
 4. See [Figure 6-37](#). Place crankcase (3) and transmission assembly (4) into fixture on arbor press (1).
 - a. Support transmission assembly on parallel supports (5).
 5. Press transmission assembly using TRANSMISSION REMOVER (2) (Part No. B-43895-1) to remove transmission assembly from crankcase half.
 6. Remove crankcase from fixture.

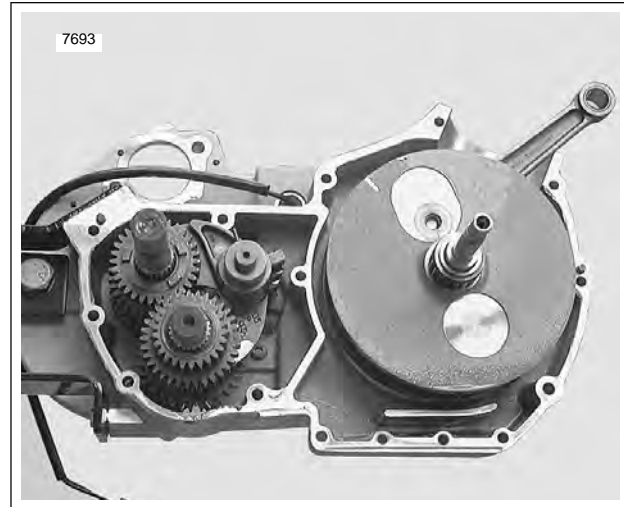
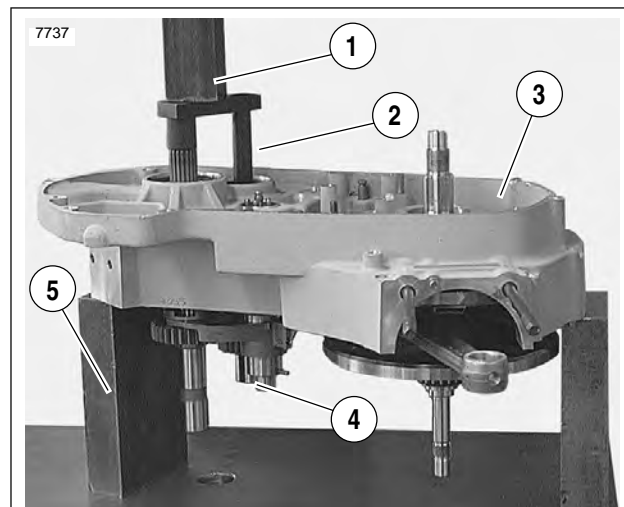

Figure 6-36. Transmission Assembly



1. Arbor Press
2. Transmission Remover (Part no. B-43985-1)
3. Crankcase
4. Transmission Assembly
5. Parallel Supports

Figure 6-37. Transmission Remover/Installer on Fixture

SHIFTER FORKS AND DRUM DISASSEMBLY

1. See Figure 6-38. Remove and discard the three fork cotter pins (14).

2. Remove three shifter fork pins (15). A small magnet is useful in freeing the fork pins.
3. Slide shifter fork drum (19) away through shifter forks. The neutral indicator pin (20) prevents removal in the other direction.
4. Remove shifter forks (16, 17, 18).

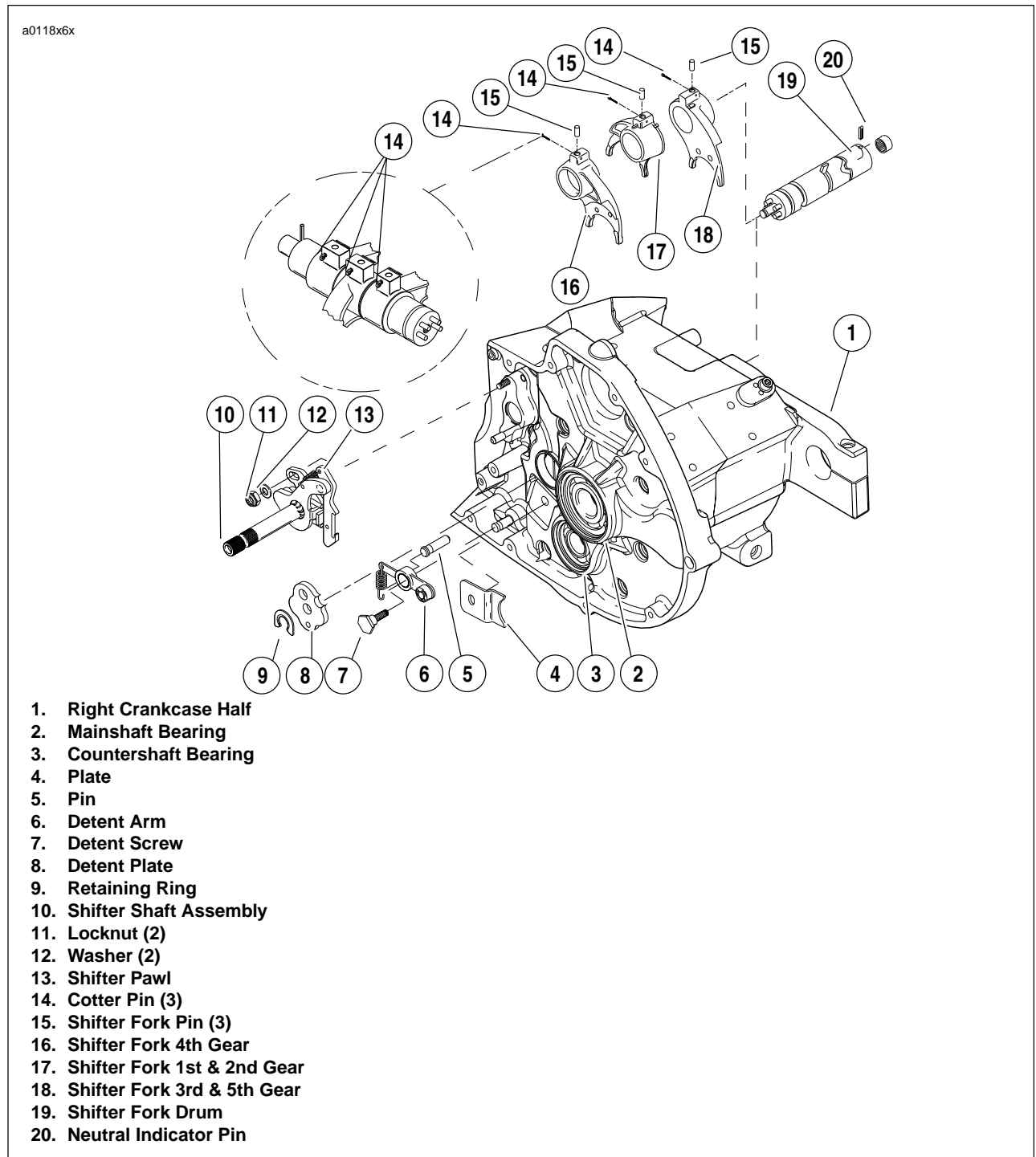

Figure 6-38. Shifter Mechanism

DISASSEMBLY

NOTE

As the transmission runs, each part develops a certain wear pattern and a kind of "set" with its mating parts. For this reason, it is important that each component be reinstalled in its original location and facing its original direction.

1. See Figure 6-39. As each component is removed, place it on a clean surface in the exact order of removal.

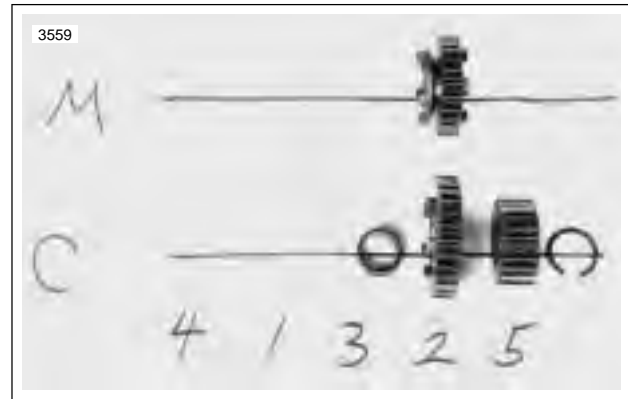

Figure 6-39.

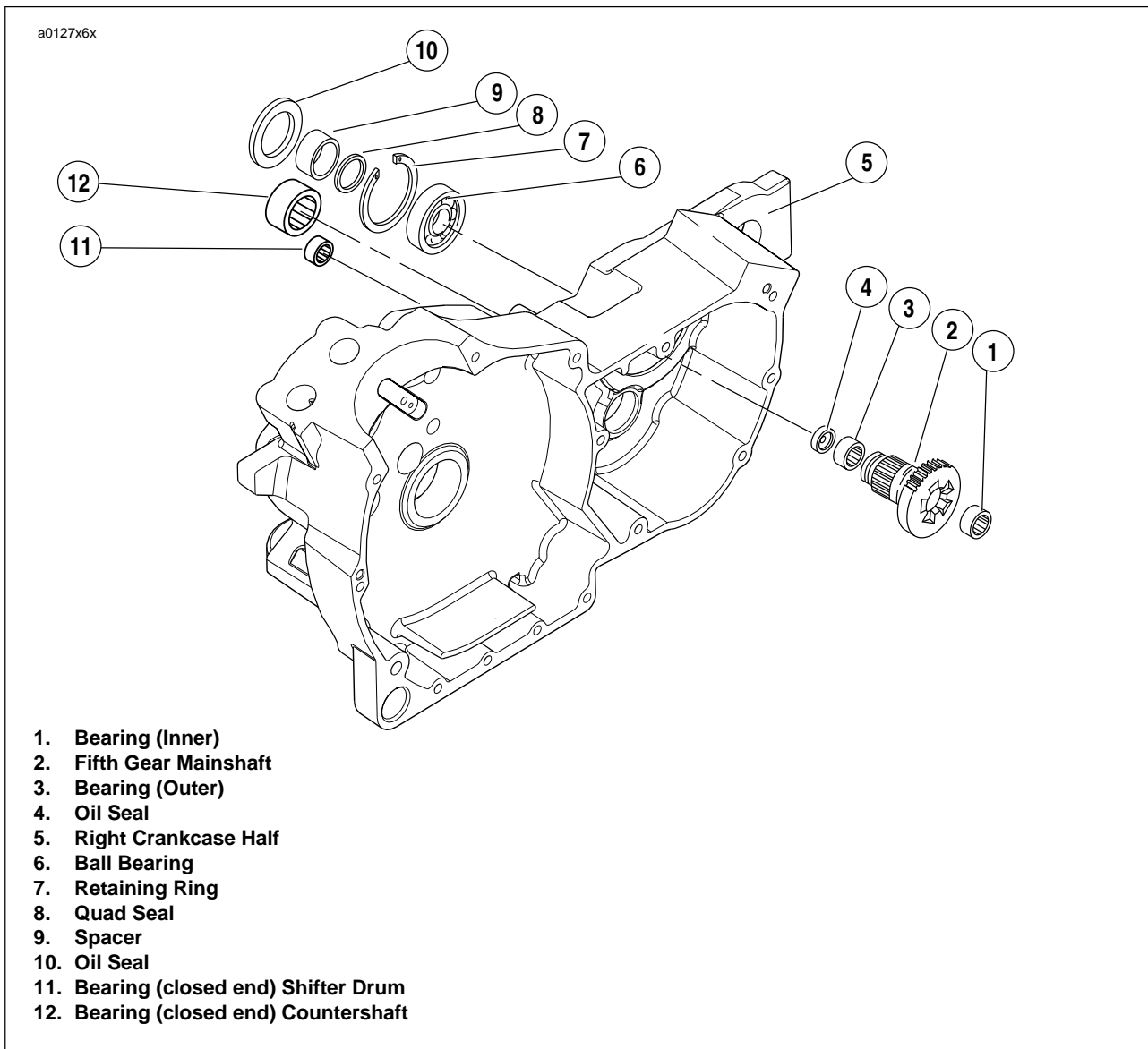
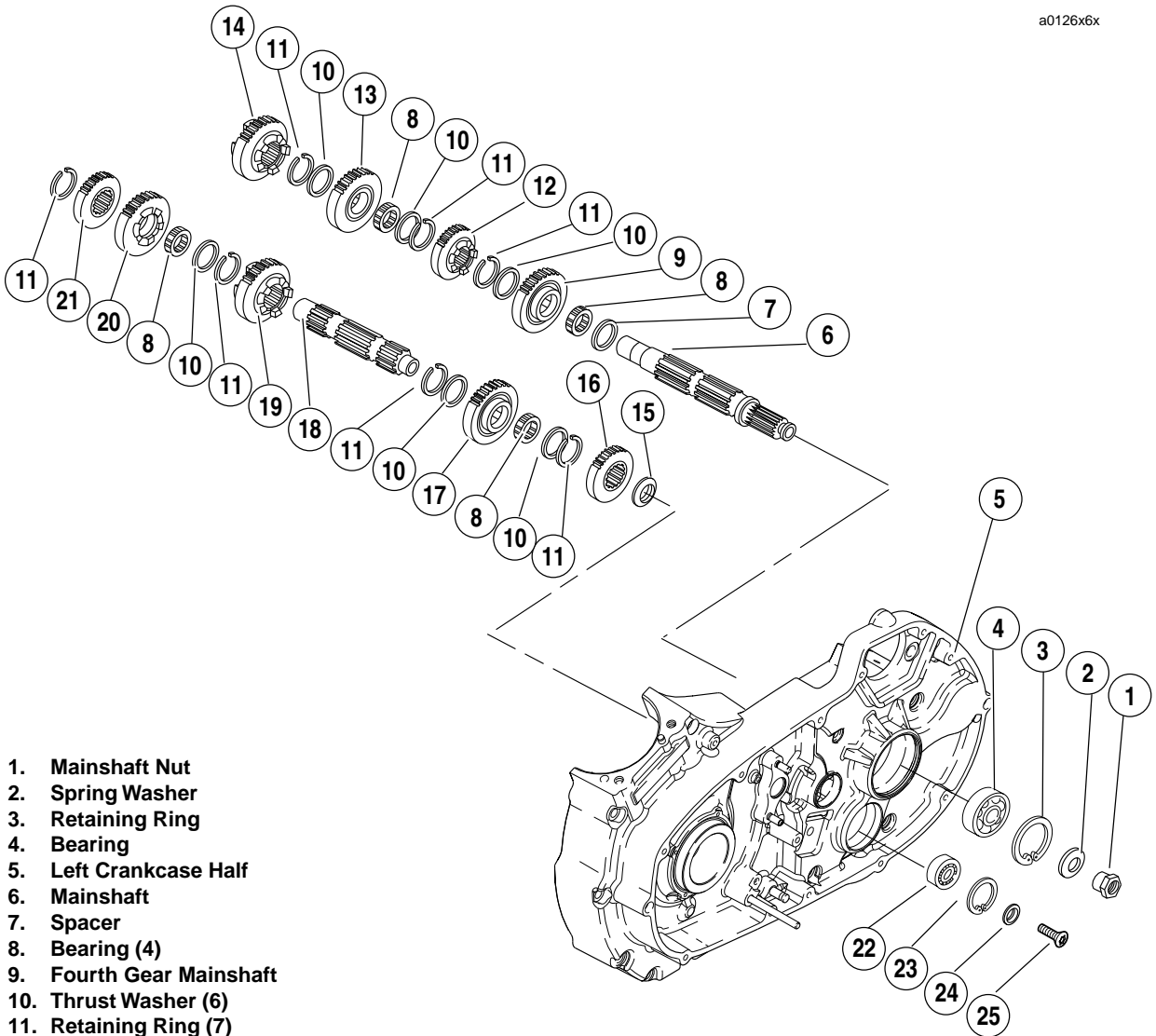

Figure 6-40. Transmission Assembly Right Crankcase Half



1. Mainshaft Nut
2. Spring Washer
3. Retaining Ring
4. Bearing
5. Left Crankcase Half
6. Mainshaft
7. Spacer
8. Bearing (4)
9. Fourth Gear Mainshaft
10. Thrust Washer (6)
11. Retaining Ring (7)
12. First Gear Mainshaft
13. Third Gear Mainshaft
14. Second Gear Mainshaft
15. Spacer
16. Fourth Gear Countershaft
17. First Gear Countershaft
18. Countershaft
19. Third Gear Countershaft
20. Second Gear Countershaft
21. Fifth Gear Countershaft
22. Bearing
23. Retaining Ring
24. Countershaft Retainer
25. Screw

Figure 6-41. Transmission Assembly Left Crankcase Half

MAINSHAFT DISASSEMBLY

1. Remove mainshaft 2nd (14) gear from mainshaft (6).
2. At mainshaft, between mainshaft 1st gear (12) and mainshaft 3rd gear (13), expand retaining ring (11) and move next to mainshaft 1st gear (12) along with thrust washer (10). Move mainshaft 3rd gear (13) as far as possible toward mainshaft 1st gear (12). Expand retaining ring (11) at opposite side of mainshaft 3rd gear (13) and slide off end of shaft. Slide thrust washer (10) off end of mainshaft
3. Remove mainshaft 3rd gear (13) and its split bearing (8)
4. Slide thrust washer (10) off end of mainshaft. Expand retaining ring (11), which is next to mainshaft 1st gear (12), and slide off end of shaft.
5. Remove mainshaft 1st gear (12) off mainshaft.
6. Expand retaining ring (11) and slide off end of shaft. Slide thrust washer (10) off end of mainshaft
7. Remove mainshaft 4th gear (9).
8. Remove split bearing (8) and spacer (7).

COUNTERSHAFT DISASSEMBLY

1. See [Figure 6-41](#). Using RETAINING RING PLIERS (Part No. J-5586) remove and discard retaining ring (11) next to countershaft 5th gear (21). Slide countershaft 5th (21), and countershaft 2nd (20) off end of countershaft (18).
2. Remove split bearing (8) that was under countershaft 2nd gear (20) and thrust washer (10), including retaining ring (11) on the countershaft (6). Slide countershaft 3rd (19) gear off free end of shaft (18).
3. Remove beveled washer (spacer) (15) and countershaft 4th gear (16).
4. Expand retaining ring (11) located next to countershaft 1st gear (17). Remove retaining ring (11) and thrust washer (10). Slide countershaft 1st gear (17) off end of shaft. Remove split bearing (8).
5. Remove thrust washer (10). Expand remaining retaining ring (11) and slide off countershaft (18).

CLEANING AND INSPECTION

WARNING

Never use compressed air to “spin-dry” bearings. Spinning bearings with compressed air can also cause a bearing to fly apart, which could result in death or serious injury.

1. Clean all parts (except bearings) in cleaning solvent and blow dry with compressed air.
2. Check gear teeth for damage. If gears are pitted, scored, rounded, cracked or chipped, they should be replaced.
3. Inspect the engaging dogs on the gears. Replace the gears if dogs are rounded, cracked, battered, chipped or dimpled.
4. Discard all retaining rings that were removed.

MAINSHAFT SUB-ASSEMBLY

CAUTION

During assembly, the split bearings (8) and the internal bores of the gears must be lubricated with **SPORT-TRANS FLUID** prior to assembly. Leaving these parts dry could accelerate wear at start-up.

1. See [Figure 6-42](#). Install new retaining ring (11) and thrust washer (10) onto mainshaft (6) in the first ring groove from the end.
2. Install split bearing (8) onto mainshaft.
3. Locate mainshaft 4th gear (9), which can be identified by the two radial grooves at one side. Slide gear (9) onto shaft. Position gear over bearing (8) next to spacer (7).
4. Place spacer (7) over mainshaft and position next to split bearing (8).
5. Slide mainshaft 1st gear (12) onto mainshaft with the fork groove facing 4th gear (9).
6. Install thrust washer (10) and new retaining ring (11) next to mainshaft 1st gear (12).

NOTE

It will be necessary to push the retaining ring into final position (ring groove) with a screwdriver.

7. Install split bearing (8) onto mainshaft.
8. Install mainshaft 3rd gear (13) onto shaft over bearing (8).
9. Install thrust washer (10) and new retaining ring (11).
10. Install mainshaft 2nd gear (14) onto shaft with the fork groove facing 3rd gear(13).

COUNTERSHAFT SUB-ASSEMBLY

1. See [Figure 6-42](#). Install new retaining ring (11) and thrust washer (10) onto countershaft (18) in the second ring groove from the end.
2. Install split bearing (8) onto countershaft.
3. Locate countershaft 1st gear (17), which can be identified by the two radial grooves at one side. Slide gear (17) onto shaft. Position gear over bearing (8).
4. Install thrust washer (10) and new retaining ring (11) next to gear (17).
5. Locate countershaft 4th gear (16). This flat, shoulderless gear is splined and has a single radial groove at one side. Position gear next to retaining ring (11) on countershaft. Place beveled washer (spacer) (15) over end of shaft with beveled side away from countershaft 4th gear (16).
6. Install countershaft 3rd gear (19) on countershaft with fork groove facing away from countershaft 1st gear (17).
7. Install new retaining ring (11) on countershaft. Position new retaining ring in the second ring groove from the end. Install thrust washer (10) next to retaining ring (11). Install split bearing (8) in seat next to washer (10).
5. Install countershaft 2nd gear (20) with the locking dogs facing countershaft 3rd gear (19).
6. Install countershaft 5th gear (21) on countershaft.
7. Install new retaining ring(11) on countershaft.
8. Install shifter forks and drum. See [6.10 TRANSMISSION ASSEMBLY](#).

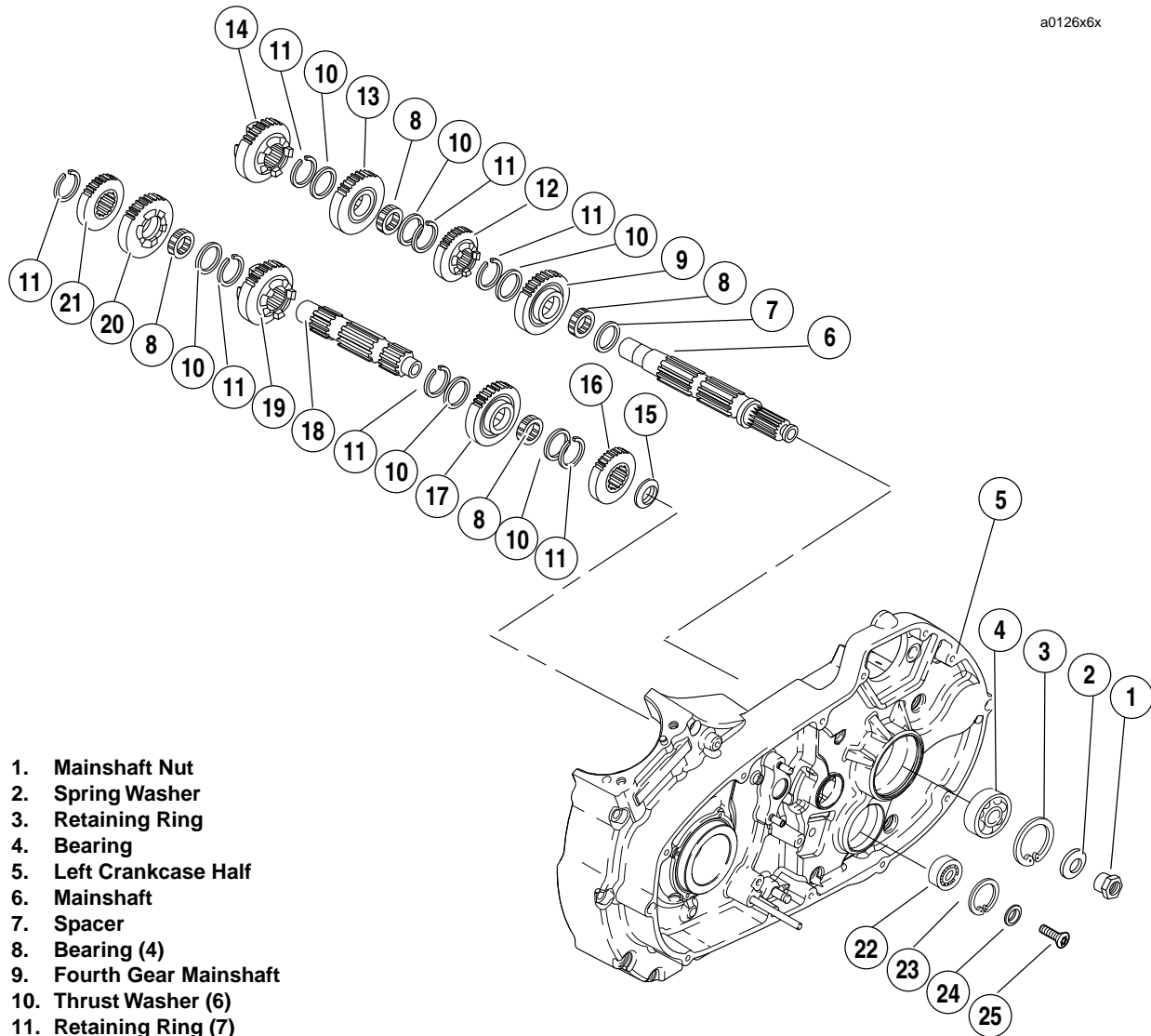

1. Mainshaft Nut
2. Spring Washer
3. Retaining Ring
4. Bearing
5. Left Crankcase Half
6. Mainshaft
7. Spacer
8. Bearing (4)
9. Fourth Gear Mainshaft
10. Thrust Washer (6)
11. Retaining Ring (7)
12. First Gear Mainshaft
13. Third Gear Mainshaft
14. Second Gear Mainshaft
15. Spacer
16. Fourth Gear Countershaft
17. First Gear Countershaft
18. Countershaft
19. Third Gear Countershaft
20. Second Gear Countershaft
21. Fifth Gear Countershaft
22. Bearing
23. Retaining Ring
24. Countershaft Retainer
25. Screw

Figure 6-42. Transmission Assembly Left Crankcase Half

SHIFTER FORKS AND DRUM ASSEMBLY

1. See [Figure 6-38](#). for shifter fork identification. See [Figure 6-43](#). Lubricate the shaft bore in fork with Sport Transmission Lube. Place 3rd and 5th gear shifter fork on shifter fork drum.
2. Lubricate the shaft bore in fork with Sport Transmission Lube. Place 1st and 2nd gear shifter fork on shifter fork drum.
3. Lubricate the shaft bore in fork with Sport Transmission Lube. Place 4th gear shifter fork on shifter fork drum.
4. See [Figure 6-38](#). Position the shifter drum shaft so that the neutral indicator switch activator pin is upward. The shaft is then in the neutral position.

CAUTION

To prevent possible cotter pin damage, the pins must be inserted through the shifter forks as shown in the inset of [Figure 6-44](#).

5. Align the hole through the top of each shifter fork with the appropriate cam groove in the shifter drum. Lubricate pins with Sport Transmission Lube. Drop pins through the holes in shifter forks. With a small screwdriver press on the pins while manipulating the forks back and forth until the pin seats in the drum groove. Secure pins in place with **new** cotter pins.
6. Align shifter fork assembly with transmission gear fork grooves.

This completes transmission assembly. Transmission components are now prepared for installation into the left crankcase half.

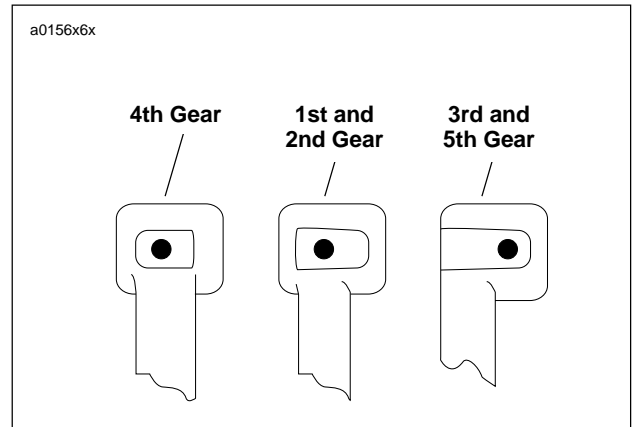
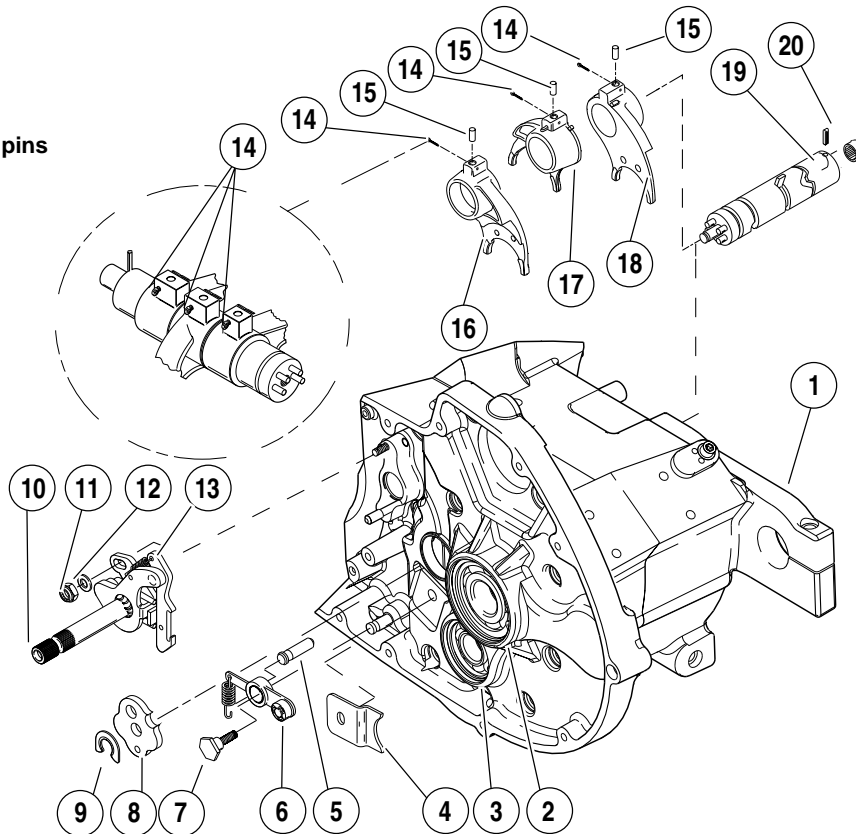

Figure 6-43. Shifter Fork Identification

a0118x6x

Insert cotter pins
as shown



1. Right Crankcase Half
2. Mainshaft Bearing
3. Countershaft Bearing
4. Plate
5. Pin
6. Detent Arm
7. Detent Screw
8. Detent Plate
9. Retaining Ring
10. Shifter Shaft Assembly
11. Locknut (2)
12. Washer (2)
13. Shifter Pawl
14. Cotter Pin (3)
15. Shifter Fork Pin (3)
16. Shifter Fork 4th Gear
17. Shifter Fork 1st & 2nd Gear
18. Shifter Fork 3rd & 5th Gear
19. Shifter Fork Drum
20. Neutral Indicator Pin

Figure 6-44. Shifter Mechanism

REMOVAL

1. Split crankcases in half. See 6.8 TRANSMISSION CASE.
2. Remove transmission as an assembly. See 6.8 TRANSMISSION CASE.
3. See Figure 6-45. From inside case tap out seal at end of mainshaft 5th gear. Discard seal.
4. Locate MAIN DRIVE GEAR REMOVER AND INSTALLER (Part No.HD-35316A) with CROSS PLATE (Part No. B-43983). Take crossplate and insert pins, at one side, into holes.
5. See Figure 6-46. Place crossplate on crankcase as shown.
6. See Figure 6-47. Insert bolt (2) through crossplate (1) and 5th gear (3).

CAUTION

When removing the main drive gear, the gear is pressed out against the resistance of the bearing inner race. Without any support at the inner race, the bearing is destroyed. Whenever the main drive gear is removed the main drive gear bearing will also have to be replaced.

9. At outside of case, place driver (4) and thrust washer (5) over end of bolt (2). Install and tighten nut (6) until 5th gear (3) is free.

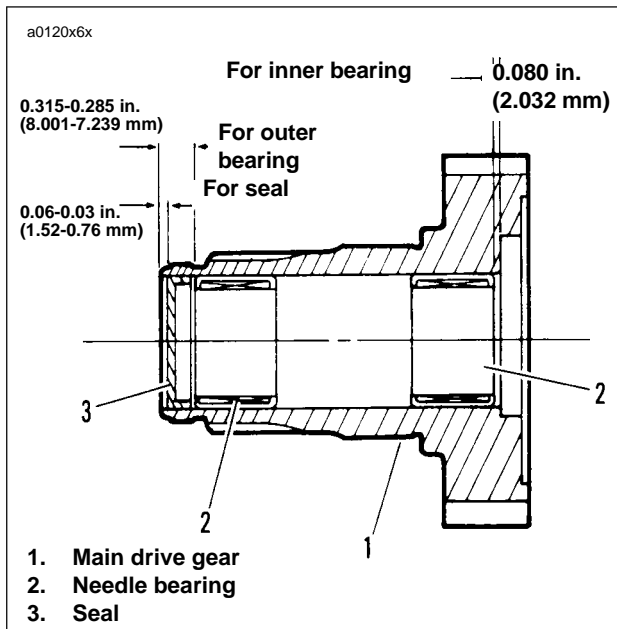

Figure 6-45. Main Drive Gear Assembly

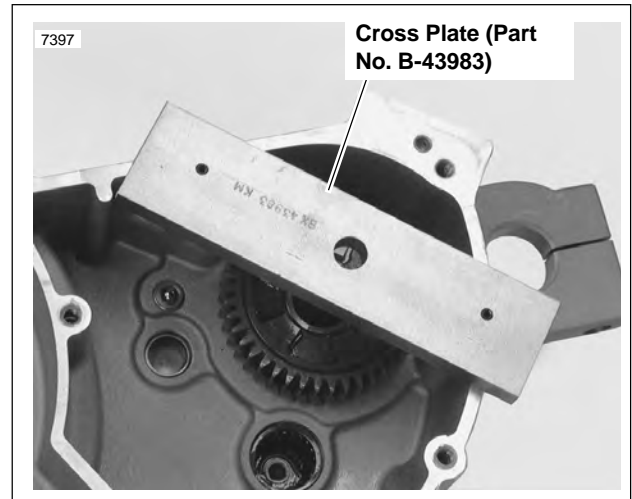

Figure 6-46. Cross Plate Mounting

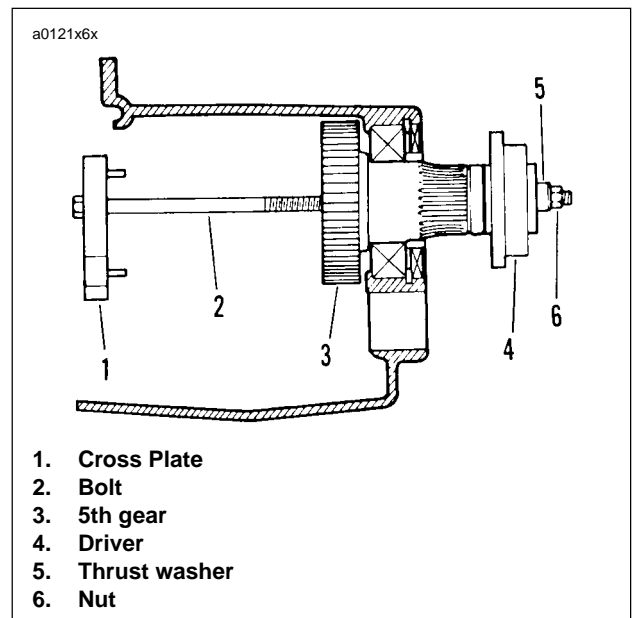

Figure 6-47. Removing Main Drive Gear

DISASSEMBLY

Drive out needle bearings from inside bore of main drive gear. Do not reuse bearings after removal.

ASSEMBLY

- See Figure 6-48. Use INNER/OUTER MAIN DRIVE GEAR NEEDLE BEARING INSTALLATION TOOL (Part No. HD-37842-A) for assembly. Select which end of tool to use.
 - The end stamped 0.080 in. (2.032 mm) is for driving the bearing into the inner end.
 - The end stamped 0.315 in. (8.001 mm) is for the outer end bearing.
- Assemble parts. The installation tool will automatically bottom on the gear when the correct depth is reached.
 - Place main drive gear on a press.
 - Press in the outer bearing to a depth of 0.315-0.285 in. (8.001-7.239 mm).
 - Press in the inner bearing to a depth of 0.080 in. (2.032 mm).

INSTALLATION

- Replace main drive gear bearing.
- See Figure 6-49. Use MAIN DRIVE GEAR REMOVER AND INSTALLER (Part No. HD-35316-A) for assembly.
 - Take bolt (2) and place washer (5) followed by main drive gear (4) over end of bolt.
 - From inside of case insert bolt and main drive gear through inner race of ball bearing.
 - Insert threaded end of bolt (2) through installer cup (3) and thrust washer (1).
 - Thread nut (6) onto end of bolt (2). Tighten nut (6) until shoulder on gear (4) bottoms against inner race of bearing.
- See Figure 6-45. Tap in new seal (3) at threaded end of 5th gear.

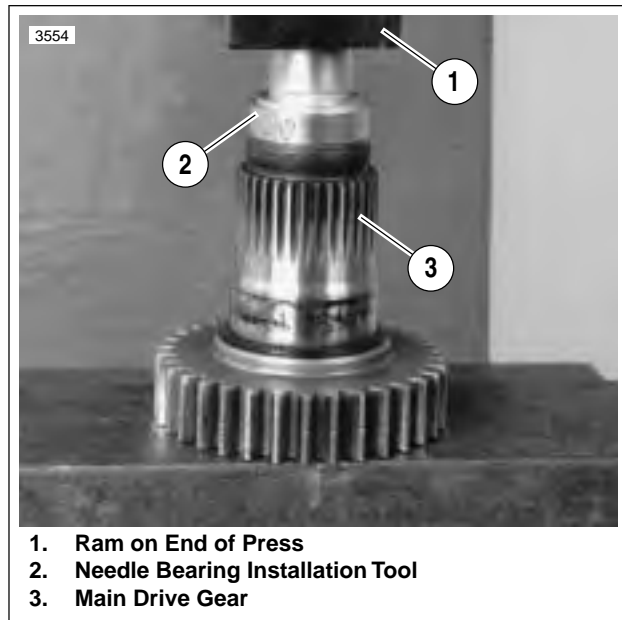

Figure 6-48. Needle Bearing Installation Tool

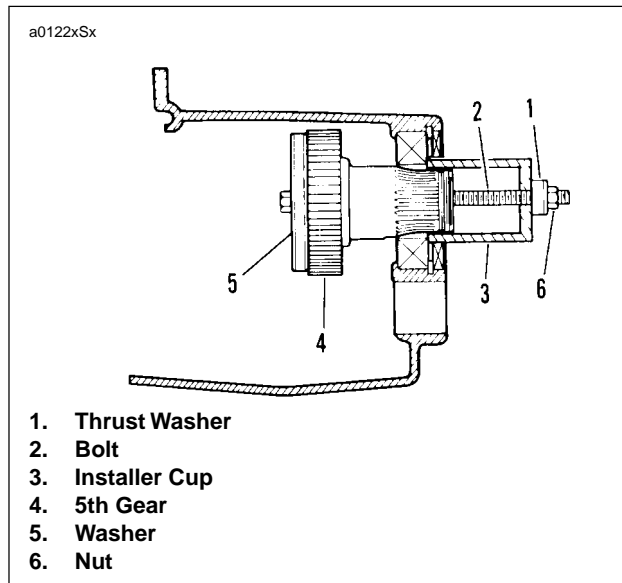

Figure 6-49. Main Drive Gear Installation

NOTE

See *Figure 6-52*. Refer to *Transmission assembly right crankcase half*, for location of items discussed on this page.

REMOVAL

1. Remove transmission assembly. See **6.9 TRANSMISSION DISASSEMBLY**.
2. See *Figure 6-50*. Remove main drive 5th gear. Use MAIN DRIVE GEAR REMOVER AND INSTALLER (Part No. HD-35316A). See **6.11 MAIN DRIVE GEAR**.
3. At outside of case remove seal next to 5th gear bearing retainer. Remove retaining ring.
4. From inside transmission case drive bearings (5th gear, countershaft or shifter shaft) out of bores. Carefully tap bearings free by working around bearing diameter to keep bearing from skewing.

INSTALLATION

Mainshaft 5th Gear Ball Bearing

1. Locate MAIN DRIVE GEAR REMOVER AND INSTALLER (Part No. HD-35316-A). See *Figure 6-50*. Place crossplate pins in appropriate holes in transmission case.
2. See *Figure 6-51*. Insert bolt (2) through crossplate (1), **new** bearing (3), driver (4) and thrust bearing (5). Thread nut (6) on end of bolt. Tighten nut carefully until bearing is seated against bore shoulder. Tighten nut (6) until bearing is seated against bore shoulder in bore.
3. At outside of case install beveled retaining ring in groove inside bearing bore with beveled side facing outside of case.
4. Lubricate bearing with SPORT-TRANS FLUID.

Countershaft Needle Bearing

1. Find a suitable bearing driver 1-1/4 in. (31.75 mm) in diameter.
2. From the outside of the case place the needle bearing open end first next to the bearing bore. Hold the driver squarely against the closed end of the bearing and tap the bearing into place. The bearing is properly positioned when it is driven inward flush or 0.030 in. (0.762 mm) below the outside surface of the case.
3. Lubricate bearing with SPORT-TRANS FLUID.

Shift Drum Needle Bearing

1. Find a suitable bearing driver 0.8125 in. (20.64 mm) in diameter.
2. From the outside of the case place the needle bearing, open end first, next to the bearing bore. Hold the driver squarely against the closed end of the bearing and tap the bearing into place. The bearing is properly positioned when driven inward flush or 0.030 in. (0.762 mm) below the outside surface.
3. Lubricate bearing with SPORT-TRANS FLUID.

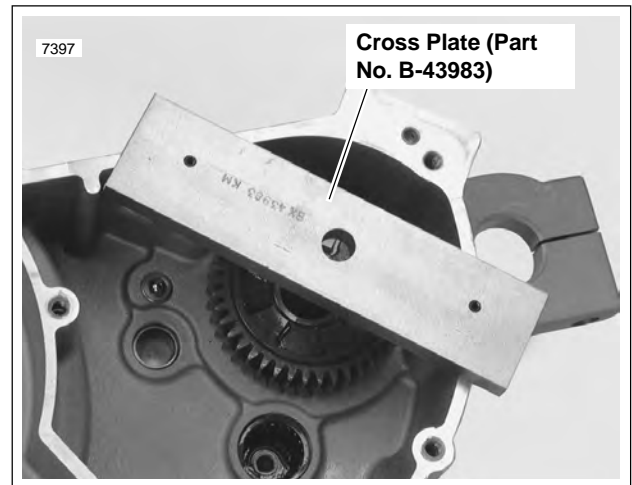

Figure 6-50. Cross Plate Mounting

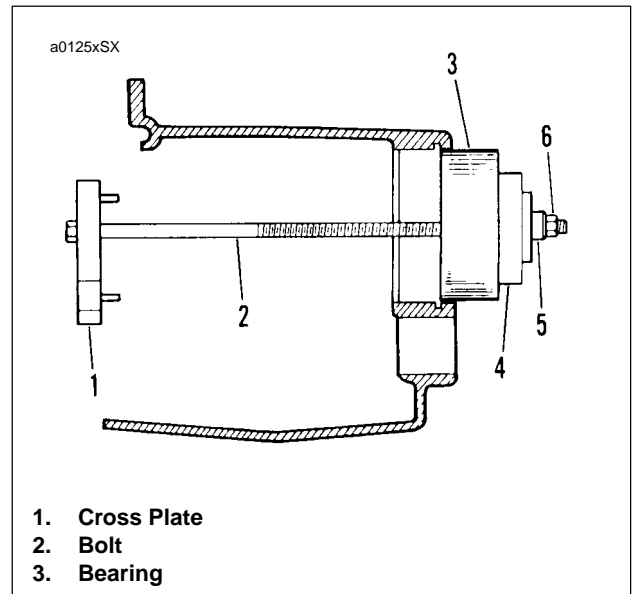
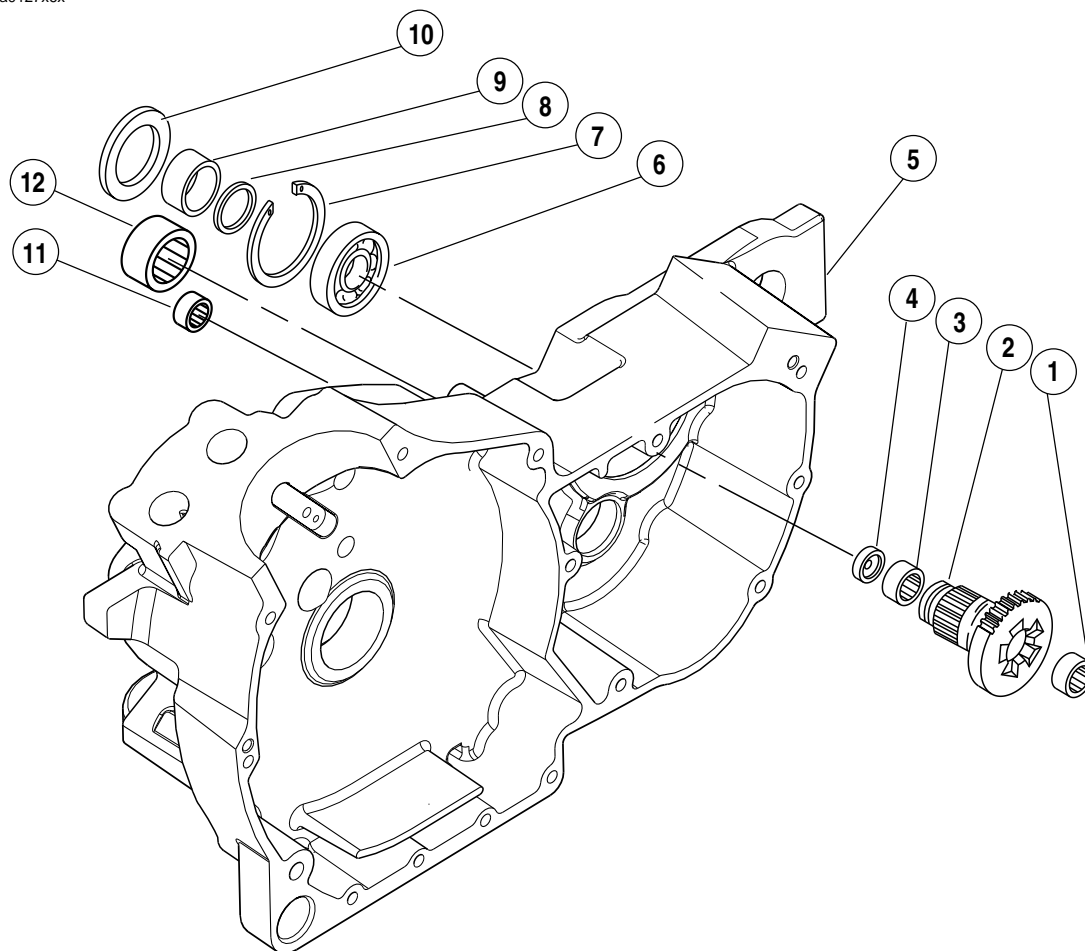

Figure 6-51. Installing Mainshaft Ball Bearing

a0127x6x



1. Bearing (2)
2. Fifth Gear Mainshaft
3. Needle Bearing (2)
4. Oil Seal
5. Right Crankcase Half
6. Ball Bearing
7. Retaining Ring
8. Quad Seal
9. Spacer
10. Oil Seal
11. Bearing (closed end) Shifter Drum
12. Bearing (closed end) Countershaft

Figure 6-52. Transmission Assembly Right Crankcase Half

NOTE

See *Figure 6-55*. Refer to *Transmission assembly left crankcase half*, for location of items discussed on this page.

REMOVAL

Mainshaft and Countershaft Bearings

1. See 6.8 TRANSMISSION CASE. Split crankcases in half.
2. See SHIFTER FORKS AND DRUM DISASSEMBLY under 6.9 TRANSMISSION DISASSEMBLY. Remove shifter forks and drum.
3. See 6.9 TRANSMISSION DISASSEMBLY. Remove countershaft and mainshaft.
4. Inspect the mainshaft and countershaft ball bearings for pitting, scoring, discoloration or other damage.
5. See *Figure 6-53*. If bearing replacement is required, remove retaining rings (1, 2). Press out bearings (3, 4) from the inside of the crankcase.

Shift Drum Bushing

1. Inspect the shifter drum bushing for pitting, scoring, discoloration or excessive wear. If bushing requires replacement press bushing out of crankcase from either side.

INSTALLATION

Mainshaft and Countershaft Bearings

1. Place crankcase on press with inside surface of crankcase downward.
2. Lay bearing squarely over bore with printed side of bearing upward. Place section of pipe or tubing (slightly smaller than outside diameter of bearing) against outer race. Press bearing into bore until bearing bottoms against shoulder.
3. Install **new** retaining ring with beveled side facing away from bearing.

Shift Drum Bushing

1. Place crankcase on press with outside surface of crankcase downward.
2. See *Figure 6-54*. Lay bushing squarely over bore. Locate socket or pipe that is slightly larger than diameter of bushing. Place socket or pipe on bushing and press into bore until bushing is flush with or 0.020 in. (0.508 mm) below inside surface. If using a pressing tool larger than diameter of bushing, the pressing tool will bottom against crankcase when bushing is flush with top surface.

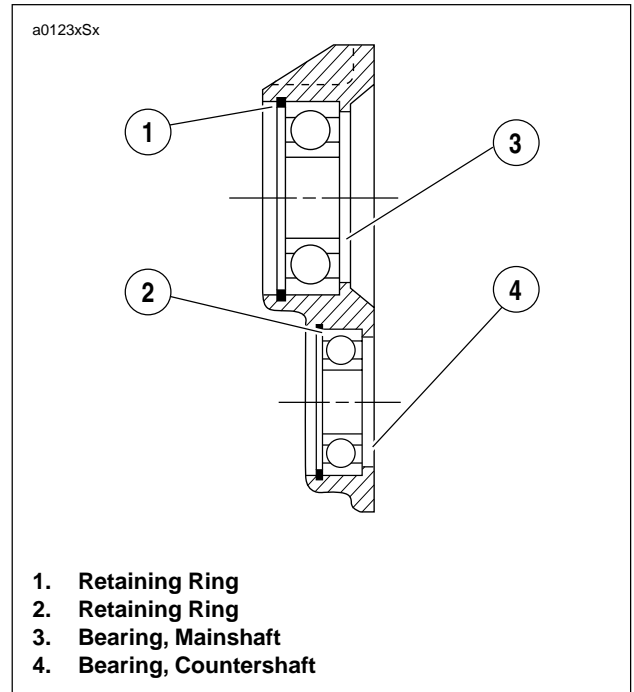

Figure 6-53. Ball Bearing Assembly

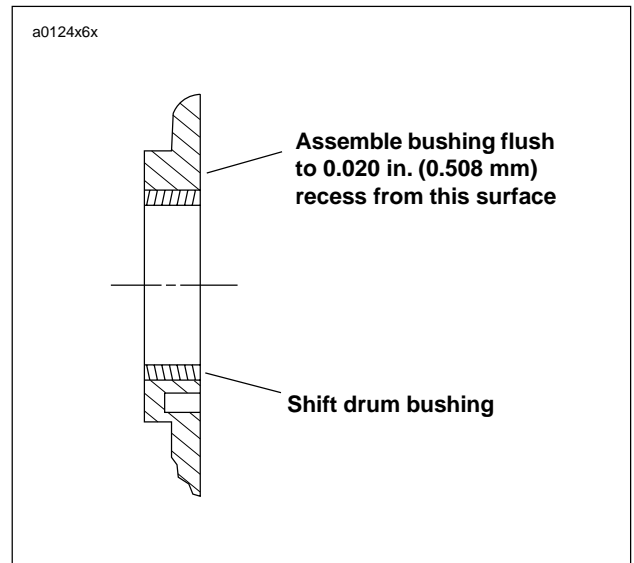
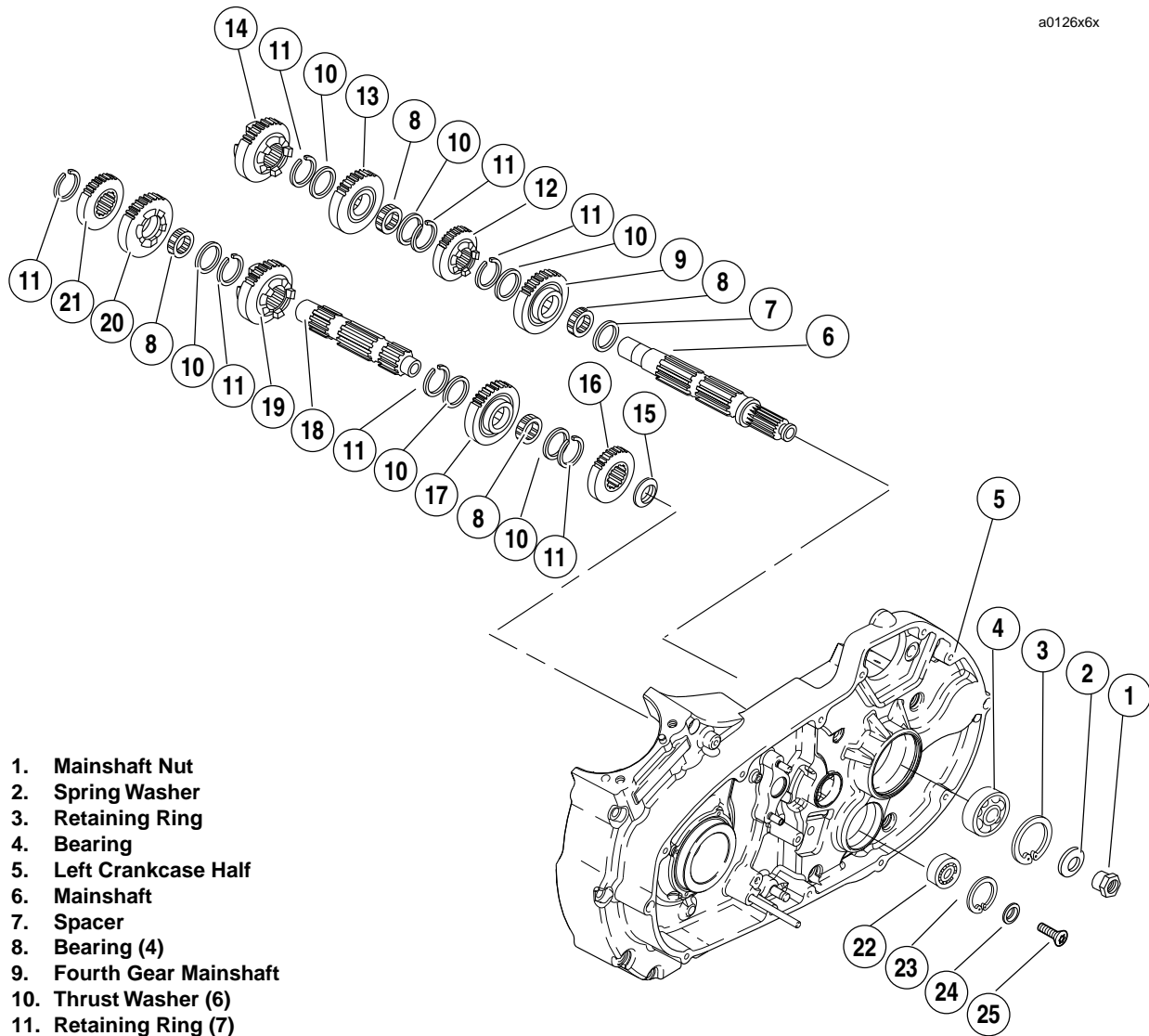

Figure 6-54. Shift Drum Bushing Assembly



1. Mainshaft Nut
2. Spring Washer
3. Retaining Ring
4. Bearing
5. Left Crankcase Half
6. Mainshaft
7. Spacer
8. Bearing (4)
9. Fourth Gear Mainshaft
10. Thrust Washer (6)
11. Retaining Ring (7)
12. First Gear Mainshaft
13. Third Gear Mainshaft
14. Second Gear Mainshaft
15. Spacer
16. Fourth Gear Countershaft
17. First Gear Countershaft
18. Countershaft
19. Third Gear Countershaft
20. Second Gear Countershaft
21. Fifth Gear Countershaft
22. Bearing
23. Retaining Ring
24. Countershaft Retainer
25. Screw

Figure 6-55. Transmission Assembly Left Crankcase Half

INSTALLATION

NOTES

- If only transmission components were serviced, the flywheel assembly should already be in place.
- If flywheels and crankcases were serviced, install the flywheel assembly before re-installing the transmission assembly.

Verify that all parts have been properly installed, as described earlier in this section under:

- 6.11 MAIN DRIVE GEAR
- 6.10 TRANSMISSION ASSEMBLY
- 6.13 LEFT CRANKCASE BEARINGS
- 6.12 RIGHT TRANSMISSION CASE BEARINGS

1. Remove left crankcase half from engine stand.
2. See Figure 6-56. Place transmission assembly onto TRANSMISSION REMOVER/INSTALLER FIXTURE (Part no. B-43985-2) on arbor press.
 - a. Install Countershaft GUIDE (Part No. B-43985-4).
 - b. See Figure 6-57. Install TRANSMISSION INSTALLER (Part no. B-43985-3) into crankcase.
3. See Figure 6-57. Press crankcase into transmission assembly until it bottoms out.
4. Remove transmission assembly and left crankcase half from fixture.
5. See Figure 6-58. Assemble crankcase halves together.
 - a. Apply a thin coat of DOW CORNING SILASTIC or 3-M 800 sealant to crankcase joint faces.
 - b. See CRANKCASE HALVES. Attach crankcase halves in torquing sequence shown.
 - c. Apply several drops of LOCTITE® thread locker 262 (red) to last few threads.
 - d. Tighten 1/4-in. fasteners to 80-110 **in-lbs** (9.0-12.4 Nm)
 - e. Tighten 5/16-in. fasteners to 15-19 **ft-lbs** (20.3-25 Nm).

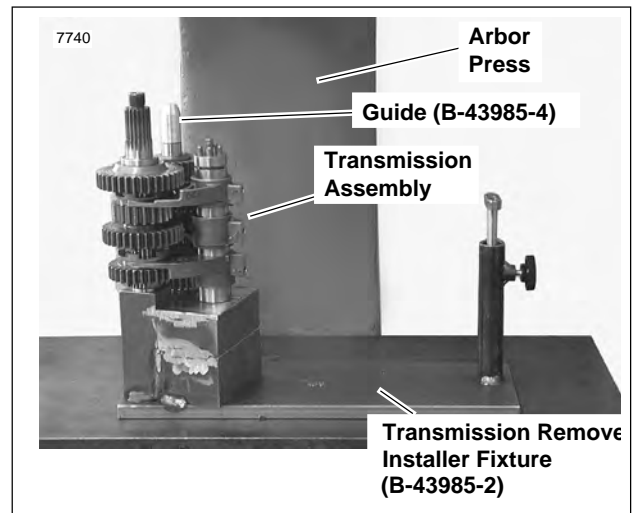

Figure 6-56. Transmission Assembly

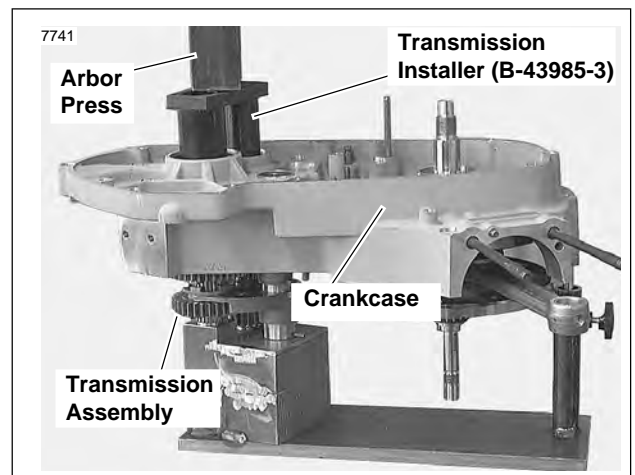

Figure 6-57. Transmission Remover/Installer on Fixture

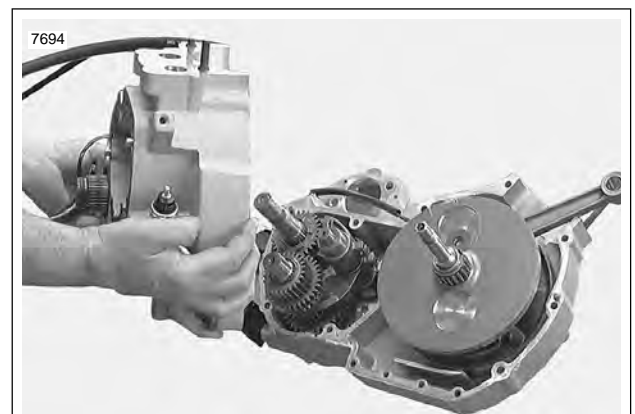
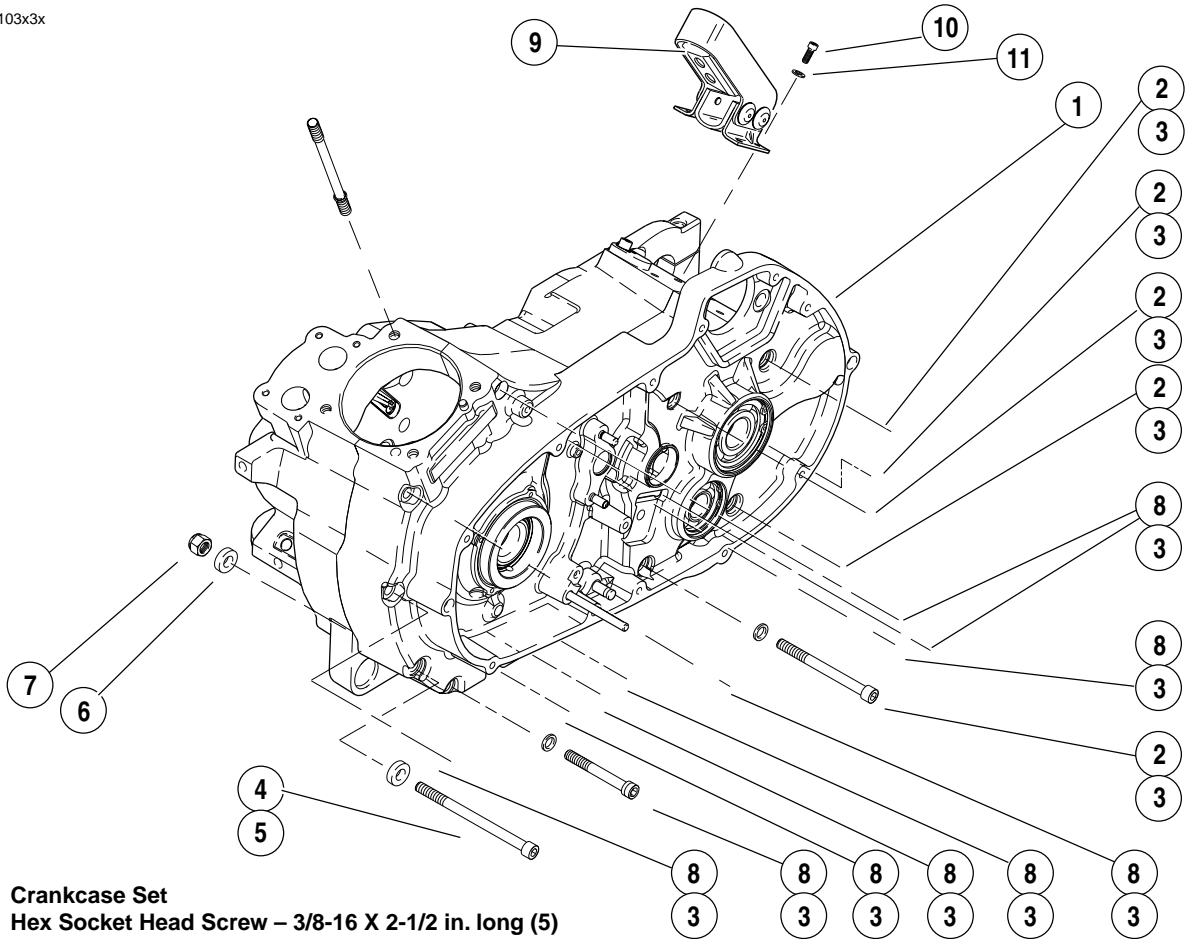

Figure 6-58. Crankcase Halves

a0103x3x



1. Crankcase Set
2. Hex Socket Head Screw – 3/8-16 X 2-1/2 in. long (5)
3. Washer 21/64 x 9/16 x 19 (14)
4. Hex Socket Head Screw – 3/8-16 X 4-1/2 in. long (1)
5. Spacer (1)
6. Washer - 3/8 I.D. X 13/16 O.D. (1)
7. Nyloc, Hex Locknut - 3/8-16
8. Bottom Case T40 TORX Bolt – 5/16-18 X 3-1/2 in. long (9)
9. Rear Isolator
10. Screw (4)
11. Washer (4)

Figure 6-59. Crankcase Hardware

ADJUSTMENT

1. See Figure 6-60. Lift pawl over drum pins and place shifter shaft assembly on studs at transmission case. Loosely install a washer and locknut on each stud.
2. Install detent plate.
 - a. Place detent plate over drum pins.
 - b. Rotate plate until blind holes in plate align with pins in end of shifter fork drum.
 - c. Install **new** retaining ring using SHIFT DRUM RETAINING RING INSTALLER (Part No. HD-39151).
3. Verify that retaining ring is fully engaged with drum groove.
4. Attach loop of spring over and into groove in post.
5. See Figure 6-61. Align shifter shaft.
 - a. Place transmission in third gear.
 - b. Place a No. 32 drill bit (0.116 in. dia.) through hole in detent plate (3), and between pawl (2) and drive pin at end of shifter drum shaft.
 - c. Push down top of crank (4) to remove all clearance between pawl and drill bit; this will correctly align pawl to shift drum pins (do not push down with too great a force, as this might cause the shifter drum to rotate).
 - d. With bit in place, tighten shifter shaft assembly bottom locknut (1) first to 90-110 **in-lbs** (10.2-12.4 Nm). Then, tighten shifter shaft assembly top locknut (1) to the same torque.
 - e. **Remove drill bit.**
6. See Figure 6-52. Place **new** quad ring over threaded end of fifth gear, and position next to the gear taper. Install spacer over threaded end of fifth gear with chamfered end toward quad ring. Slide spacer up against bearing.
7. Install seal.
 - a. Coat lips of seal with SPORT-TRANS FLUID.
 - b. Position seal over spacer with lips of seal toward case.
 - c. Use MAIN DRIVE GEAR SEAL INSTALLER (Part No. HD-41496) to gently tap seal into bore of case until the outside of seal is flush with outer edge of bore.

NOTE

It is acceptable to recess seal to about 0.030 in. (0.762 mm) below outer edge of bore. Seal will be controlled by tool.

8. See Figure 6-62. Position retention collar next to end of counter shaft with beveled side facing outward.
 - a. Apply several drops of LOCTITE® thread locker 243 (blue) to last few threads.
 - b. Insert screw (1) through retention collar (2) and thread into end of shaft.
 - c. Place transmission in gear, and tighten TORX screw (1) to 13-17 ft-lbs (18-23 Nm) torque.

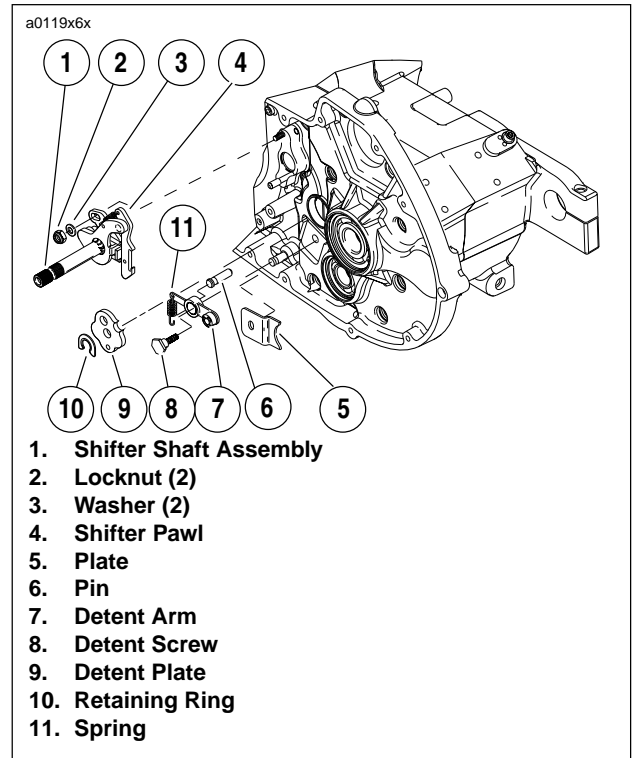

Figure 6-60. Installing Shifter

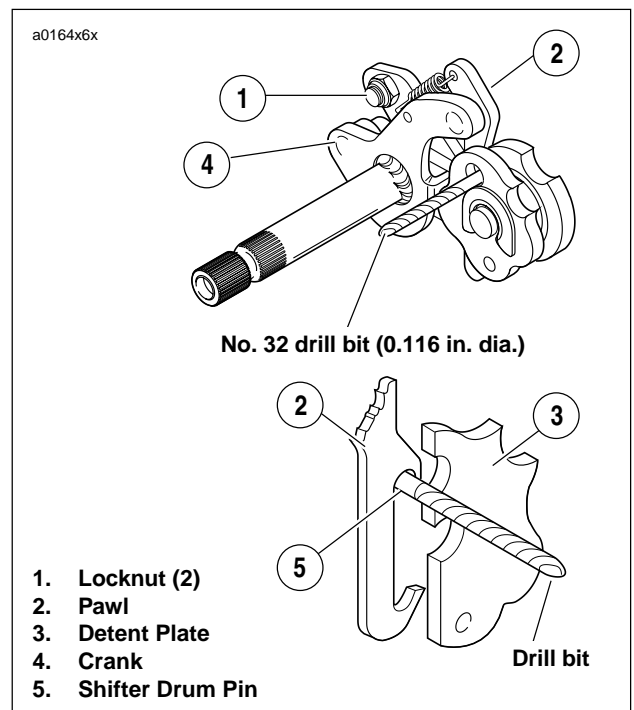

Figure 6-61. Shifter Shaft Assembly Alignment

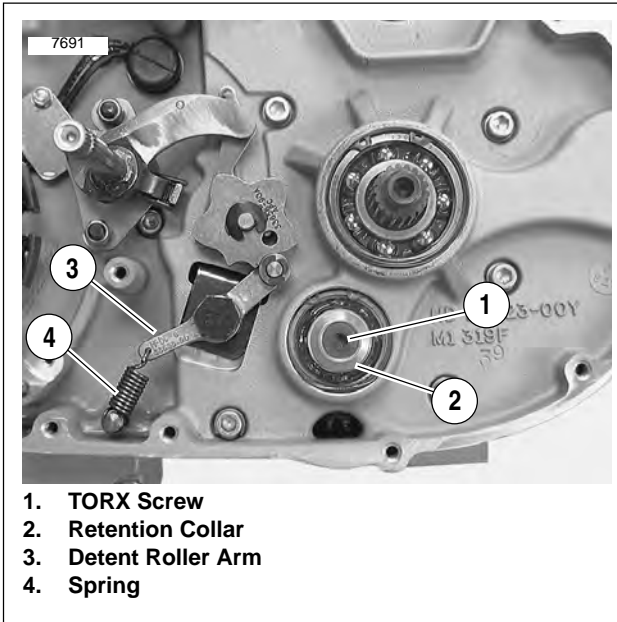

Figure 6-62. Countershaft Retainer

REMOVAL

- See Figure 6-63. Place transmission in first gear. Remove two socket head screws (5) and lockplate (4).

NOTE:

Transmission sprocket nut has left-hand threads. Turn nut clockwise to loosen and remove from main drive gear shaft.

- See Figure 6-63. Remove transmission sprocket nut (3) from main drive gear shaft (1).
 - See Figure 6-64. Secure pulley using SPROCKET LOCKING TOOL (1) (Part No. B-43982).

INSTALLATION

- See Figure 6-63. Install transmission sprocket (2) with secondary drive belt onto main drive gear shaft (1).
- Place transmission in neutral.
- Apply a few drops of LOCTITE® thread locker 262 (red) to the **left-hand threads** of transmission sprocket nut (3). Position nut with washer-faced side facing transmission sprocket. Turn the nut **counterclockwise** to install it onto main drive gear shaft.
 - See Figure 6-64. Install SPROCKET HOLDING TOOL (1) (Part No. B-43982) as shown.
 - See Figure 6-65. Use MAINSHAFT LOCKNUT WRENCH (Part No. HD-94660-37B) and a torque wrench to tighten sprocket nut to 50 ft-lbs (67.8 Nm) INITIAL torque, ONLY.
 - See Figure 6-66. Scribe a line on the transmission sprocket nut and continue the line on the transmission sprocket as shown.
 - Tighten the transmission sprocket nut an additional 30°-40°.
 - See Figure 6-63. Install lockplate over nut so that two of lockplate's four drilled holes (diagonally opposite) align with sprocket's two tapped holes.

NOTE

The lockplate has four screw holes and can be turned to either side, so you should be able to find a position without having to additionally tighten the nut. If you cannot align the screw holes properly, the nut may be additionally **TIGHTENED** until the screw holes line up, but do not exceed 45° as specified above. Never **LOOSEN** nut to align the screw holes.

- See Figure 6-66. If lockplate will not align with holes, tighten nut to 45° maximum.

CAUTION

Maximum allowable tightening of sprocket nut is 45° of counterclockwise rotation, after initially tightening to 50 ft-lbs. Do not loosen sprocket nut while attempting to align the screw holes. If you cannot align lockplate and sprocket screw holes, nut may be additionally tightened 45° as specified above. Tightening too much or too little may cause the nut to come loose during vehicle operation.

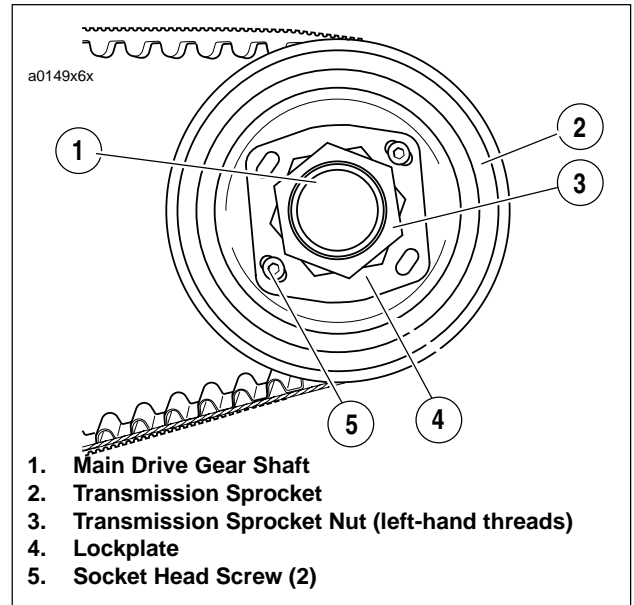

Figure 6-63. Transmission Sprocket

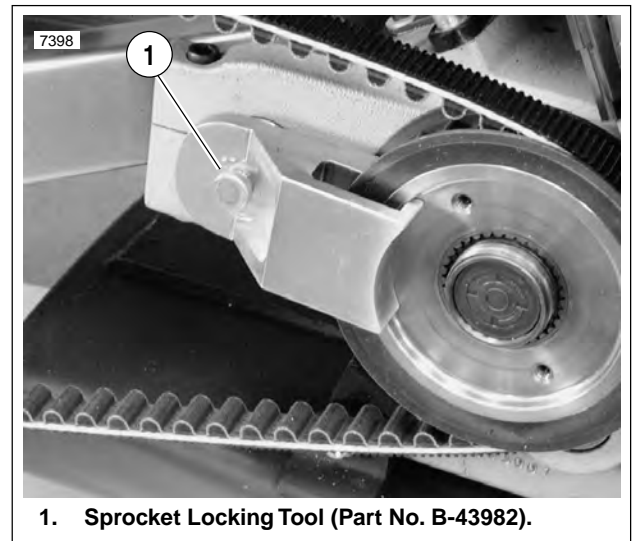

Figure 6-64. Sprocket Locking Tool

4. If you cannot align lockplate and sprocket screw holes, nut may be additionally tightened until screw holes align.
5. See [Figure 6-63](#). Install two socket head screws through aligned holes of lockplate and into tapped holes of sprocket. Tighten to 90-110 **in-lbs** (10.2-12.4 Nm).

NOTE

The original equipment socket head screws (5) have thread-locking compound applied to them. Since this compound remains effective for about three removal/installation cycles, the original screws may be reused up to three times. After the third removal/installation cycle, replace both screws with **new** screws identical to the original.

6. Install the remaining removed components in the reverse order of the removal procedures. See the procedures listed in the respective component sections.
7. Fill transmission to proper level with fresh lubricant. See [6.4 CLUTCH](#).

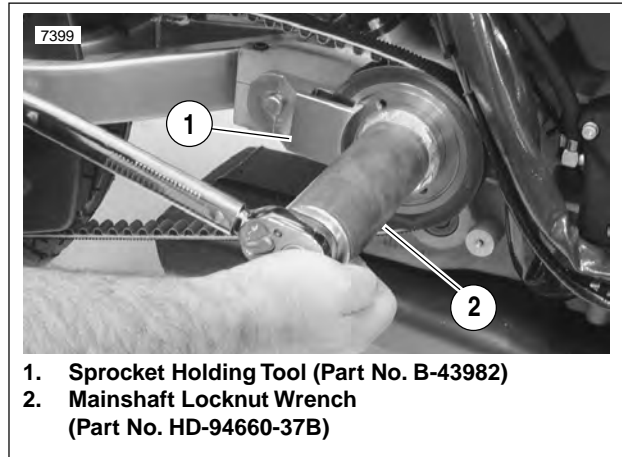

Figure 6-65. Transmission Sprocket Tightening

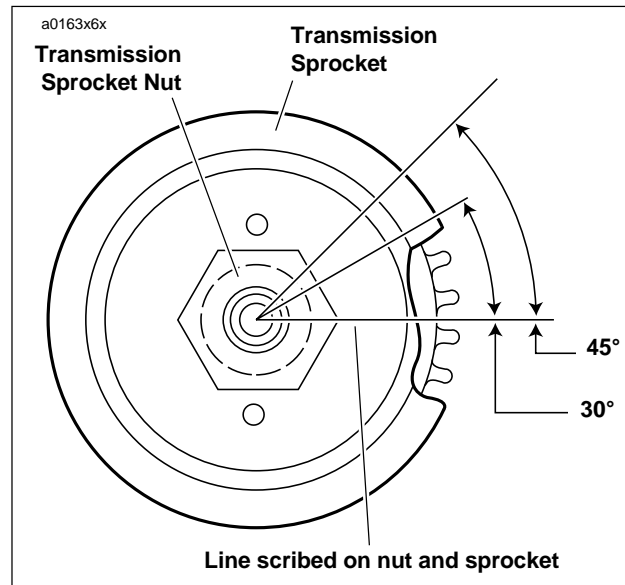

Figure 6-66. Aligning Transmission Sprocket

SUBJECT	PAGE NO.
7.1 Specifications	7-1
7.2 Ignition System	7-3
7.3 Diagnostic Charts	7-6
7.4 Throttle Position Sensor	7-12
7.5 Bank Angle Sensor	7-13
7.6 Ignition/Headlamp Key Switch	7-14
7.7 Auto Enrichener	7-16
7.8 Ignition Module/Cam Position Sensor	7-18
7.9 Ignition Coil	7-23
7.10 Spark Plug Cables	7-25
7.11 Starter/Ignition Interlock	7-26
7.12 Diodes	7-33
7.13 Charging System	7-34
7.14 Alternator	7-40
7.15 Voltage Regulator	7-42
7.16 Battery	7-43
7.17 Headlamp	7-47
7.18 Tail Lamp	7-50
7.19 Turn Signals	7-51
7.20 Turn Signal Flasher	7-53
7.21 Handlebar Switches	7-54
7.22 Horn	7-56
7.23 Neutral Indicator Switch	7-57
7.24 Fuses And Circuit Breakers	7-58
7.25 Electronic Speedometer	7-59
7.26 Speedometer Sensor	7-61
7.27 Speedometer Performance Check	7-62
7.28 Indicators	7-67
7.29 Main Wiring Harness	7-68

BATTERY	
Rating	12 VDC/12AH/200CCA
Type	Sealed

ALTERNATOR	
AC Voltage Output	19-26 VAC per 1000 engine RPM
Stator Coil Resistance	0.2-0.4 Ohms

REGULATOR	
Voltage Output @ 75°F	14.3-14.7 VDC
Amperes @ 3600 RPM	22 Amps

IGNITION TIMING SPARK OCCURRENCE		
RPM	TP Sensor	
	Low Voltage (PT)	High Voltage (WOT)
1200 RPM (Idle)	20° BTDC	18° BTDC
3000 RPM	30° BTDC	18° BTDC
6000 RPM	45° BTDC	35° BTDC
Curve Switch Point	TP Sensor Input 2.4V	
Rev Limit	6500 RPM	

IGNITION COIL RESISTANCE	
Primary Winding	0.4-0.6 ohms
Secondary Winding	7,720-9,440 ohms

SPARK PLUG CABLE RESISTANCE	
Spark Plug Cable	2,375-5,833 ohms

ELECTRICAL SYSTEM	AMPERES
Main Circuit Breaker	30
Ignition Fuse	7.5
Light Fuse	15
Accessory Fuse	7.5
System Fuse	15
Key Switch Fuse	15

LAMP DESCRIPTION		BULBS REQUIRED	WATTS	AMPS	PART NUMBER
Headlamp	High/Low	1	60/55	5.0/4.58	67713-86
Marker lamps	Tail/Stop Lamp	1	5/21	0.42/1.75	Y0401B.2U
	Turn Signal Lamp, Front and Rear (1 bulb each)	4	10	0.83	68968-99Y
Indicator lamps (in speedometer)	High Beam Indicator	Non-replacable LEDs			
	Turn Signal Indicator				
	Oil Pressure Indicator				
	Neutral Indicator				

TORQUE VALUES

ITEM	TORQUE		NOTES
Battery Terminal Bolts	60-96 in-lbs	6.8-10.9 Nm	Metric, page 7-45
Battery Cable to Frame Bolt	5-8 ft-lbs	7-11 Nm	Metric, page 7-45
Circuit Breaker Nylon Acorn Nuts	1-3 in-lbs	0.1-0.3 Nm	Page 7-31
Circuit Breaker Metal Nuts	15-18 in-lbs	1.7-2 Nm	Page 7-31
Flasher Relay Screw	4-6 ft-lbs	5.4-8 Nm	Page 7-53
Handlebar Switch Housing Screws, left side	25-33 in-lbs	2.8-3.7 Nm	Metric, page 7-55
Handlebar Switch Housing Screws, right side	12-17 in-lbs	1.4-1.9 Nm	Metric, page 7-54
Headlamp Bezel Screws	12-14 in-lbs	1.4-1.6 Nm	Metric, page 7-47
Headlamp Housing Mounting Screws	12-14 ft-lbs	16-19 Nm	Metric, page 7-47
Horn Mounting Nut	25-33 in-lbs	2.6-3.7 Nm	Metric, page 7-56
Ignition Coil Mounting Screws	4-6 ft-lbs	5.4-8 Nm	LOCTITE THREADLOCKER 243 (blue), page 7-24
Ignition/Key Switch Mounting Screws	4-6 ft-lbs	5.4-8 Nm	LOCTITE THREADLOCKER 243 (blue), page 7-15
Ignition Module Plate Mounting Screws	15-30 in-lbs	1.7-3.4 Nm	Page 7-20
Neutral Indicator Switch	3-5 ft-lbs	4.0-6.8 Nm	LOCTITE THREADLOCKER 243 (blue), page 7-57
Rotor Cup Mounting Screw	43-53 in-lbs	4.9-6.0 Nm	LOCTITE THREADLOCKER 243 (blue), page 7-20
Rotor Mounting Bolts	90-110 in-lbs	10.2-10.4 Nm	LOCTITE THREADLOCKER 243 (blue), page 7-41
Sidestand Switch Screws	30-36 in-lbs	3.3-4.1 Nm	LOCTITE THREADLOCKER 243 (blue), page 7-30
Spark Plug	11-18 ft-lbs	14.9-24.4 Nm	LOCTITE ANTI-SEIZE on threads, page 7-3
Starter Relay Screw	30-36 in-lbs	3.3-4.1 Nm	Page 7-31
Stator Mounting Screws	30-40 in-lbs	3.4-3.5 Nm	T-27 TORX with retaining compound, replace after removal, page 7-41
Tail Lamp Mounting Locknuts	25-33 in-lbs	2.6-3.7 Nm	Metric, page 7-50
Throttle Position Sensor Screws	13-23 in-lbs	1.5-2.6 Nm	Tamper-resistant T20 TORX, page 7-12
Timing Inspection Hole Plug	10-15 ft-lbs	14-20 Nm	Page 7-21
Turn Signal Nuts (front and rear)	25-28 in-lbs	2.8-3.2 Nm	Page 7-51, 7-52
Voltage Regulator Screws	4-6 ft-lbs	5.4-8 Nm	LOCTITE THREADLOCKER 243 (blue), page 7-42

MODEL YEAR CHANGE

All 2001 Blast P3 model Buell motorcycles come equipped with a Bank Angle Sensor.

GENERAL

The vehicle uses a breakerless inductive-discharge ignition system. The system has both a primary and secondary circuit. The primary circuit consists of the battery, ignition switch, primary coil winding, computerized ignition timer and associated wiring. The secondary circuit consists of the secondary coil, spark plug and associated wiring. See Figure 7-

1.

The computerized ignition system contains five assemblies.

Ignition Module

The ignition module is mounted in the gear case cover. The module has two functions. First, it computes the spark advance for proper ignition timing. Second, it opens and closes the low-voltage circuits between the battery and ignition coil to produce high-voltage discharge to the spark plug. The ignition module on the P3 Blast also contains an integrated cam position sensor.

Above 6500 rpm, the ignition module will automatically reduce power to prevent over revving.

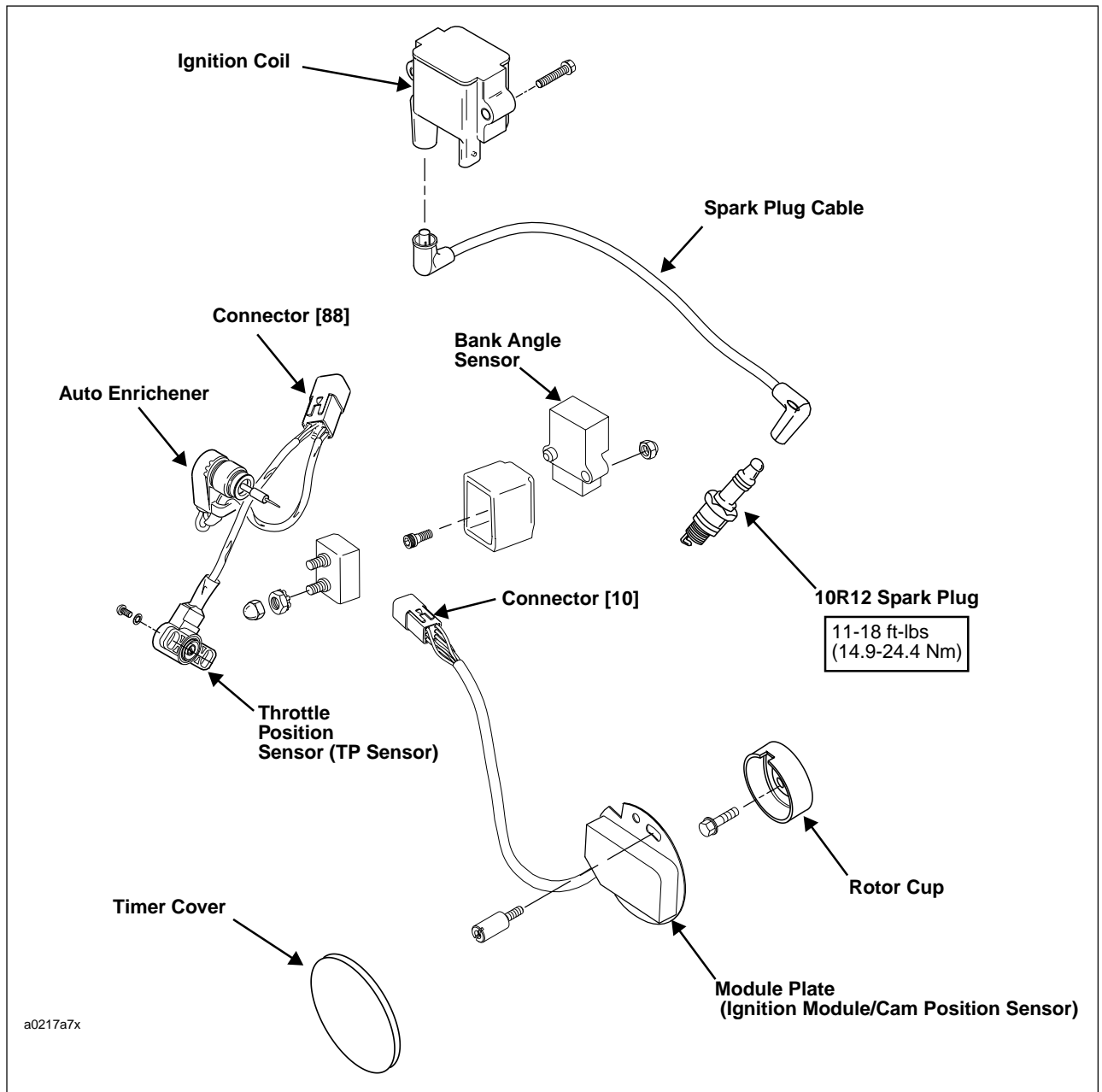

Figure 7-1. Ignition System Components

The ignition module contains all the solid-state components used in the ignition system. The dwell time is fixed. The ignition module has added protection against transient voltages, continuous reverse voltage protection and damage due to jump starts. The system will operate down to 6.0 VDC. The ignition module is fully enclosed to protect it from vibration, dust, water and oil. The module is not repairable. Replace the unit if it fails.

The ignition module is programmed with two spark advance curves to meet varying engine loads. The ignition module selects the proper curve based on TP Sensor output voltage which is continuously monitored. This system ensures correct timing to suit starting and high-speed requirements.

A single ignition coil fires the spark plug at the end of the compression stroke (no waste spark), thereby igniting the air/fuel mixture.

Throttle Position Sensor (TP Sensor) and Auto Enrichener

The Throttle Position Sensor (TP Sensor) is attached to the throttle shaft on the carburetor. The TP Sensor voltage is high when the throttle is opening during acceleration and under high engine load conditions and the voltage is low during deceleration and under low engine load conditions. The high or low voltage signal from the TP Sensor is communicated to the Ignition Module which selects the correct spark advance curve (change between high and low curve takes place at TP Sensor input 2.4V).

The low voltage signal curve (throttle less than 1/2 open, <2.4V TP Sensor input), selected for maximum spark advance under normal light-load cruising conditions, provides improved fuel economy and performance. The high voltage signal curve (throttle more than 1/2 open, >2.4V TP Sensor input) minimizes spark knock while maintaining performance under high-load conditions (acceleration and highway driving).

The Auto Enrichener is located on the carburetor and controls the cold idle speed of the motorcycle and enriches the air/fuel mixture. The Auto Enrichener circuit is grounded and operative for 2-5 minutes after the motorcycle is started. The ground is completed by the ignition module.

Bank Angle Sensor

The Bank Angle Sensor provides input to the ignition module on whether or not the vehicle lean angle is greater than 55 degrees. If vehicle lean angle exceeds 55 degrees, the Bank Angle Sensor will shut off power to the ignition.

Rotor and Cam Position Sensor

The rotor and cam position sensor (cam position sensor is integrated with the ignition module) are located in the gear-case cover on the right side of the motorcycle. The rotor is mounted on the camshaft and operates at one-half crankshaft speed. As the rotor turns, a slot in its outside diameter breaks the magnetic field of a Hall-effect device mounted on the cam position sensor. The output of the Hall-effect device is a logic-type signal that corresponds to the timing information from the spinning rotor. This technique gives accurate timing information down to "0" speed.

The ignition system produces a spark near top dead center (TDC) for starting. At RPM's and loads above this, the system produces a spark 0°-45° before TDC. The whole timing program can be shifted by mechanical rotation of the integrated

ignition module plate. See [1.19 IGNITION TIMING AND IDLE SPEED ADJUSTMENT](#).

See the wiring diagrams at the end of this section for additional information on ignition system circuits.

TROUBLESHOOTING

For poor performance, poor fuel economy or excessive ping-ing, see [DRIVABILITY TROUBLESHOOTING](#) on Page 7-10. Also refer to Table 4-1 in Section 4 for Fuel System Troubleshooting.

For incorrect idle speed, see [DRIVABILITY TROUBLESHOOTING](#) on page 7-15.

If the engine will not start, or if hard starting or missing indicates a faulty operating ignition system, perform the tests listed below.

Check for Ignition Spark

1. Remove seat and fuel tank. See Sections 2 and 4.
2. Disconnect spark plug cable from spark plug. Check condition of plug and cable. Clean or replace as necessary. See [7.10 SPARK PLUG CABLE](#).
3. Install SPARK PLUG TESTER (HD-26792) to spark plug cable end.
4. Turn ignition key switch to IGN and engine stop switch to ON and pull in clutch lever.
5. With transmission in neutral, press electric starter button. Check for a spark across plug electrode gap.
 - a. If a spark is produced, problem is not in electronic system or coil. Check carburetion, enrichener and spark plug.
 - b. If no spark is produced, check battery voltage and battery connection. Battery voltage must be at least 12.6 VDC. Charge battery if voltage is low.
6. Verify that the ground strap from the front isolator to the frame is in good condition. If there is still no spark, then perform the tests under [No Ignition Spark](#).

No Ignition Spark

See [Figure 7-2](#). To conduct the following tests, it will be necessary to assemble a set of jumper wires.

Cut two wires of ample length to reach from a good ground connection to the negative terminal of the coil primary. If a suitable capacitor is not available, use a condenser (such as the type used in earlier breaker point ignition systems).

When conducting Step 4 of the previous spark tests, use the SPARK PLUG TESTER (HD-26972). During the testing procedures, check for spark across the spark plug electrodes.

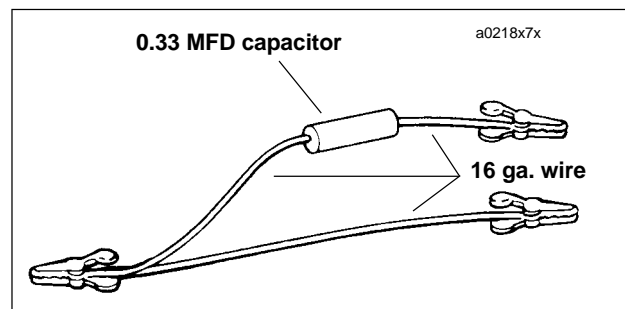

Figure 7-2. Test Jumper

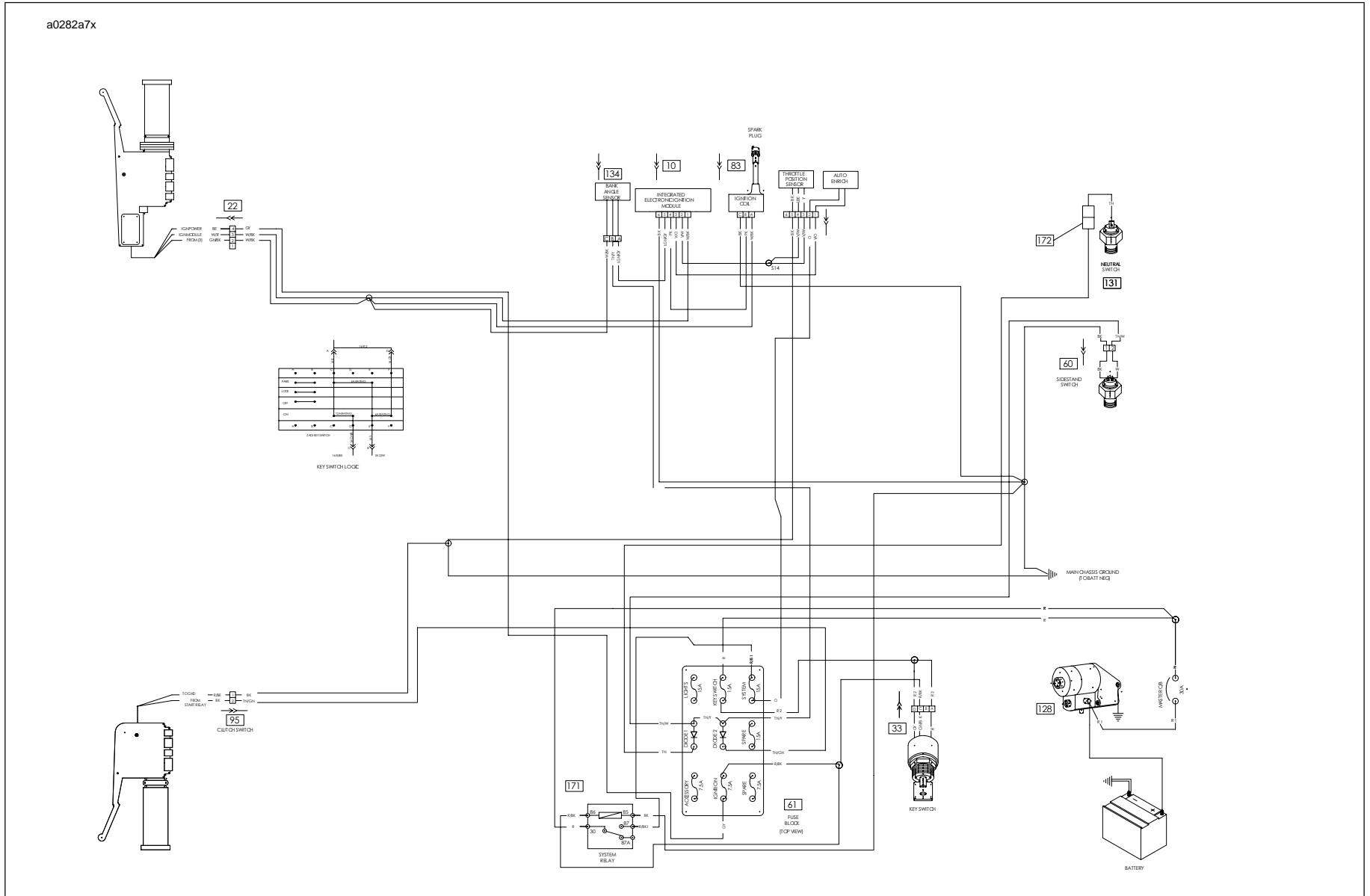
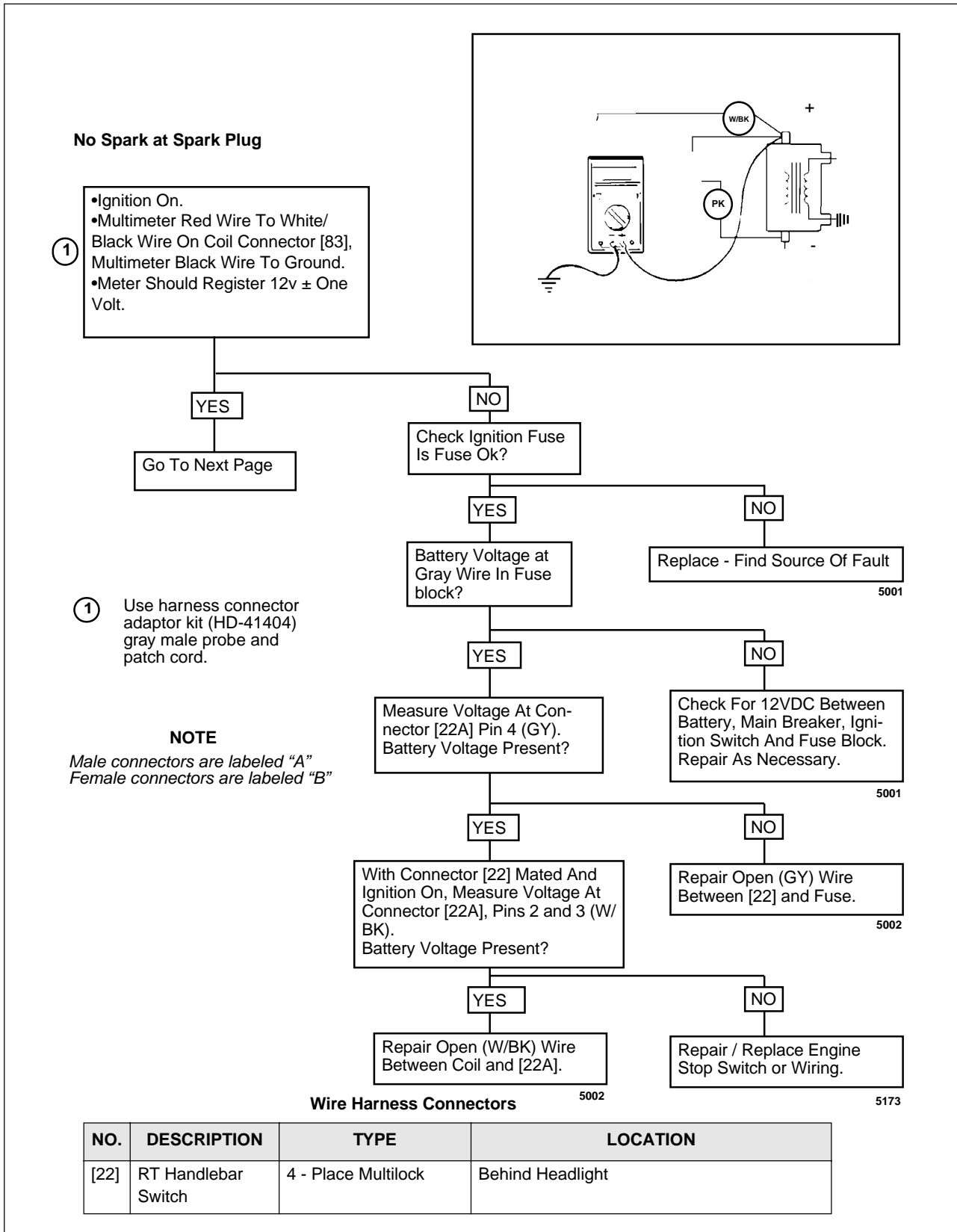

Figure 7-3. Ignition System Circuit



Wire Harness Connectors

NO.	DESCRIPTION	TYPE	LOCATION
[22]	RT Handlebar Switch	4 - Place Multilock	Behind Headlight

Figure 7-4. No Spark At Spark Plug

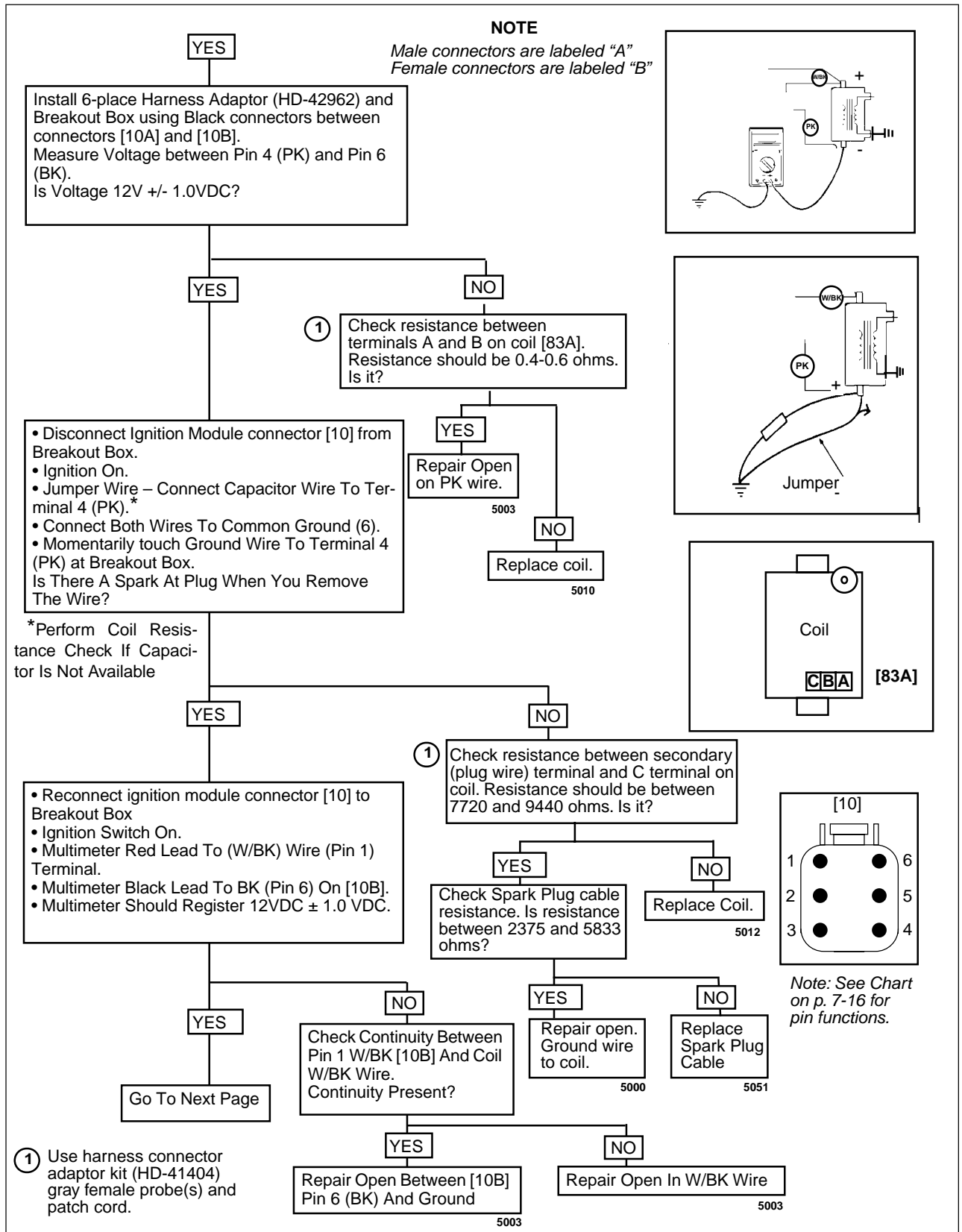

Figure 7-5. No Spark At Spark Plug

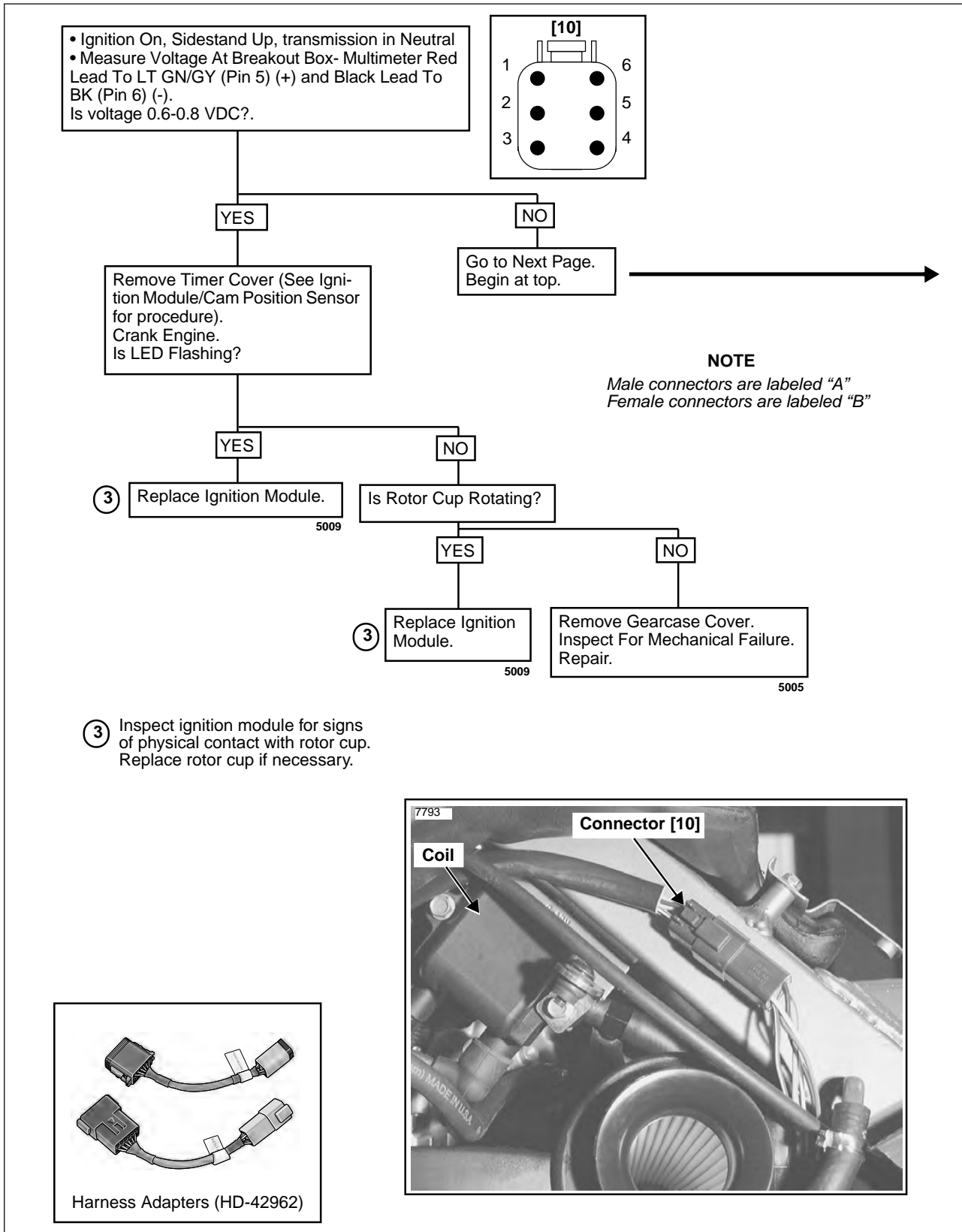

Figure 7-6. No Spark At Spark Plug

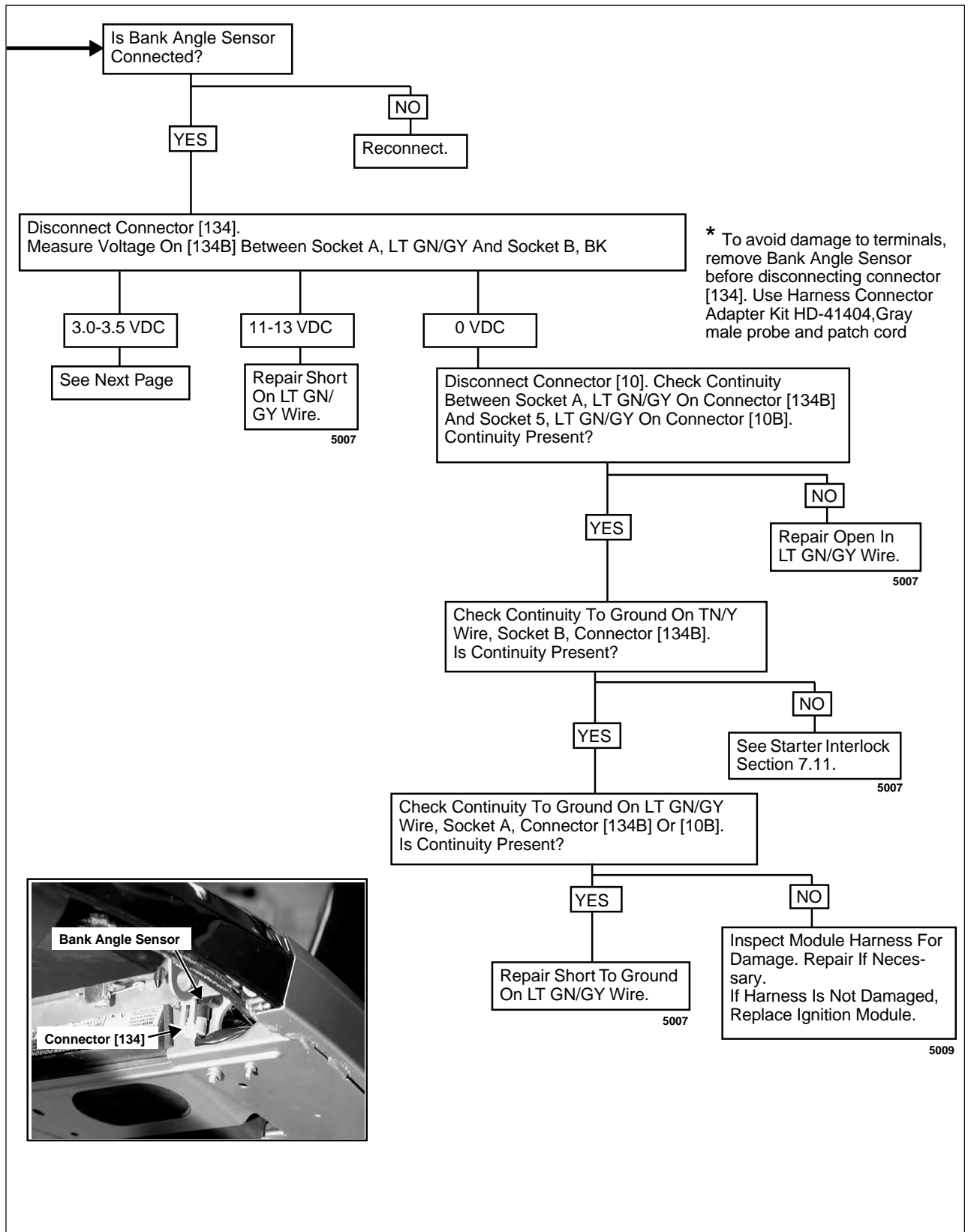

Figure 7-7. Continuous or No Spark At Spark Plug

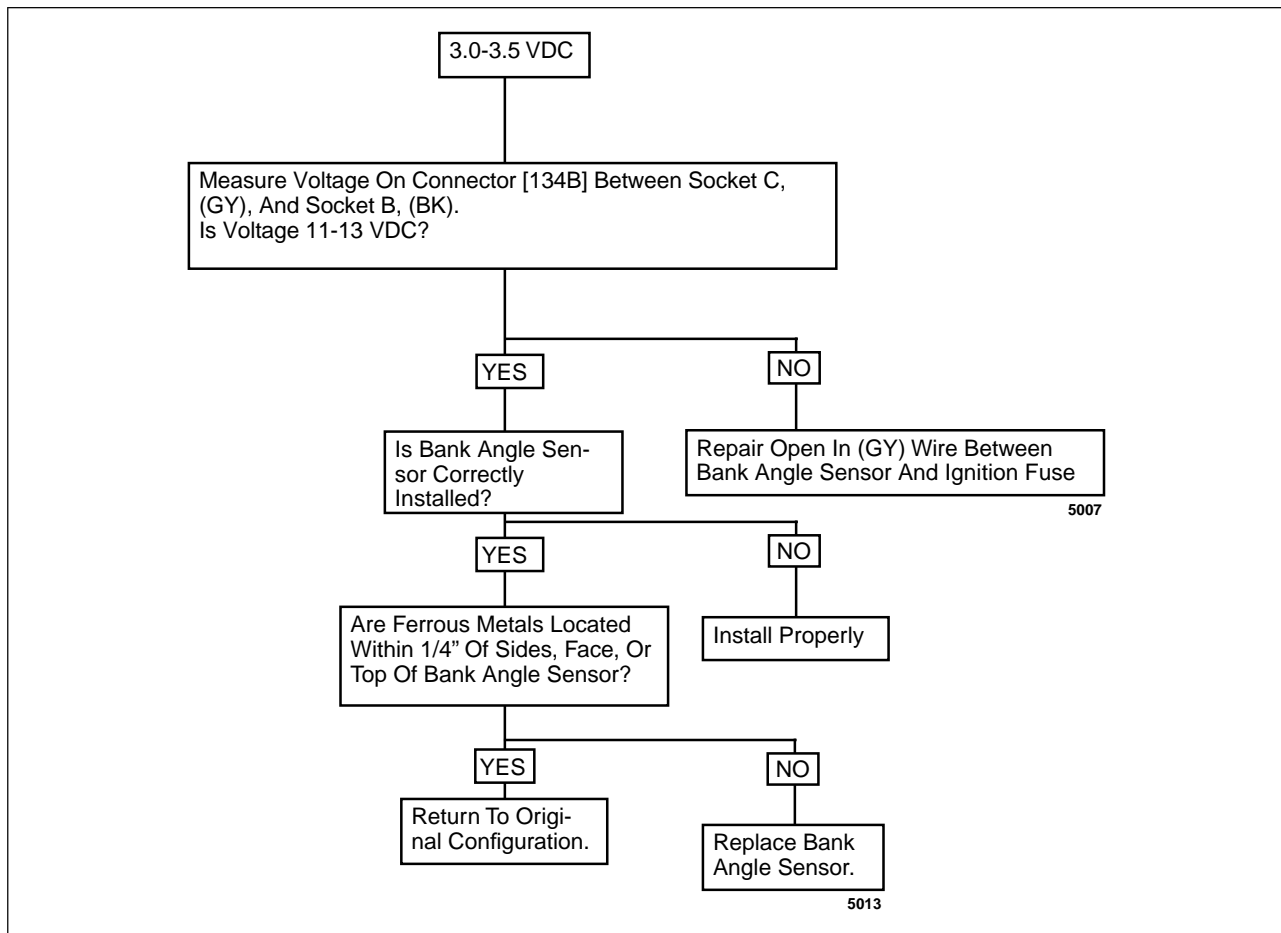

Figure 7-8. Continuous or No Spark At Spark Plug

DRIVABILITY TROUBLESHOOTING

Poor Performance, Poor Fuel Economy, Excessive Pinging

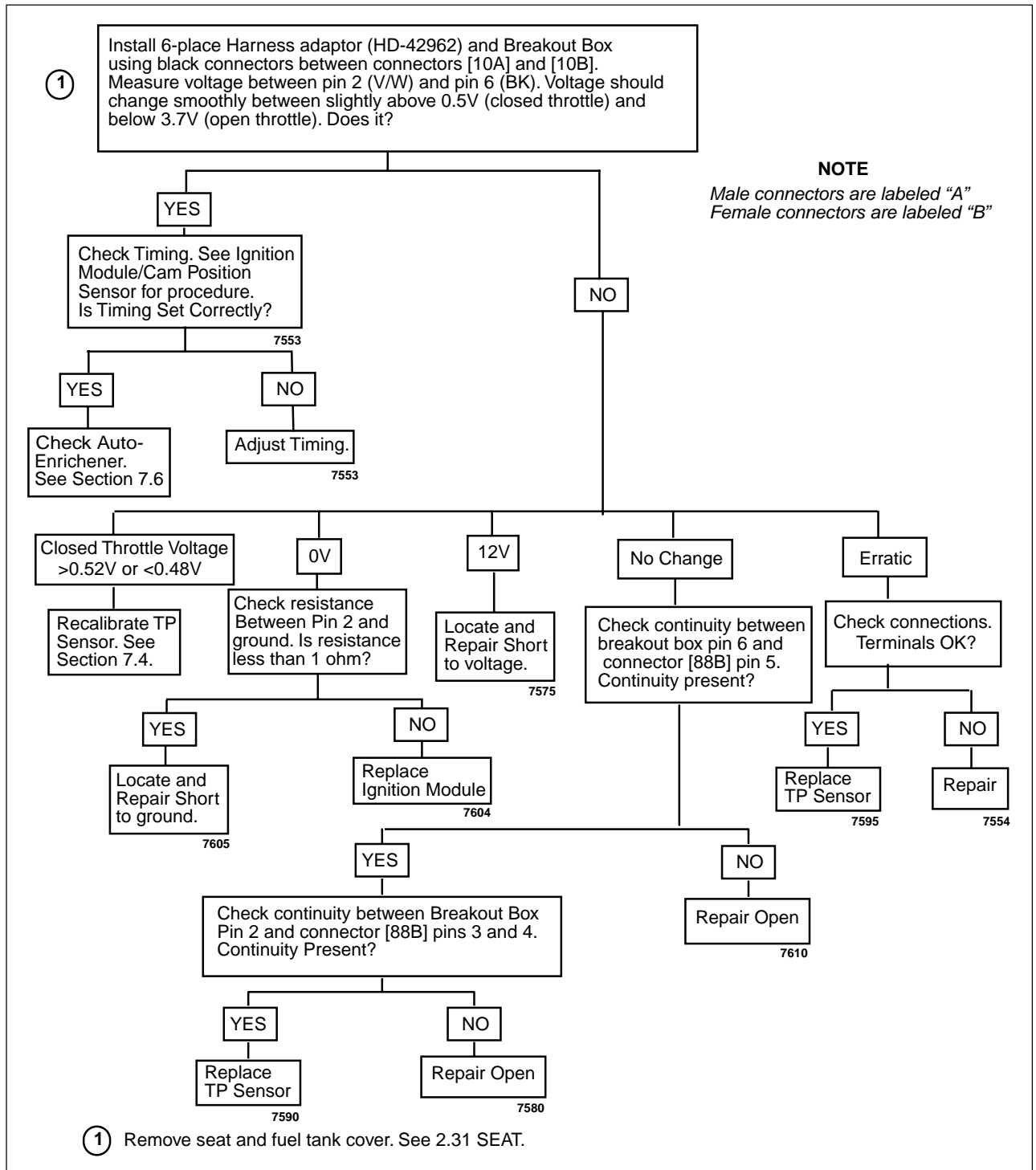

Figure 7-9. Drivability Troubleshooting

GENERAL

See [Figure 7-10](#). The throttle position sensor voltage determines which spark advance curve the ignition module selects. The throttle position sensor (TP Sensor) is located on the carburetor. The TP Sensor is not repairable. Replace the unit if it fails.

See [4.6 THROTTLE POSITION SENSOR](#) for information on replacing the throttle position sensor.

See diagnostic chart on previous page for troubleshooting information.

CALIBRATION/TESTING

NOTE

To gain access to the Throttle Position Sensor, remove the carburetor and airbox as an assembly. See [Section 4](#).

1. Back off idle adjustment screw so throttle plate is fully closed.
2. Completely open and close the throttle by rotating the throttle control through its full range of motion.
3. Loosen the two TP Sensor mounting screws (tamper-resistant T20 TORX screws) using special TORX bit (Snap-On Part No. TTXR20E) just enough to allow TP Sensor to rotate.
4. Install 6-place Harness adaptor (HD-42962) and Break-out Box using black connectors between connectors [10A] and [10B].
5. Turn ignition switch to ON. Using a multimeter measure voltage between pin 2 (V/W) and pin 6 (BK).
6. Adjust (rotate) TP Sensor until voltage reading is 0.5V +/- 0.02V.
7. Completely open and close the throttle by rotating the throttle control through its full range of motion. Verify that voltage reading increases smoothly as throttle is opened. Voltage at Wide Open Throttle (WOT) should not exceed 3.7V.
8. Tighten TP Sensor mounting screws to 13-23 **in-lbs** (1.5-2.6 Nm) and verify that voltage output reading has not changed.
9. Adjust idle speed. See [1.19 IGNITION TIMING AND IDLE SPEED ADJUSTMENT](#).

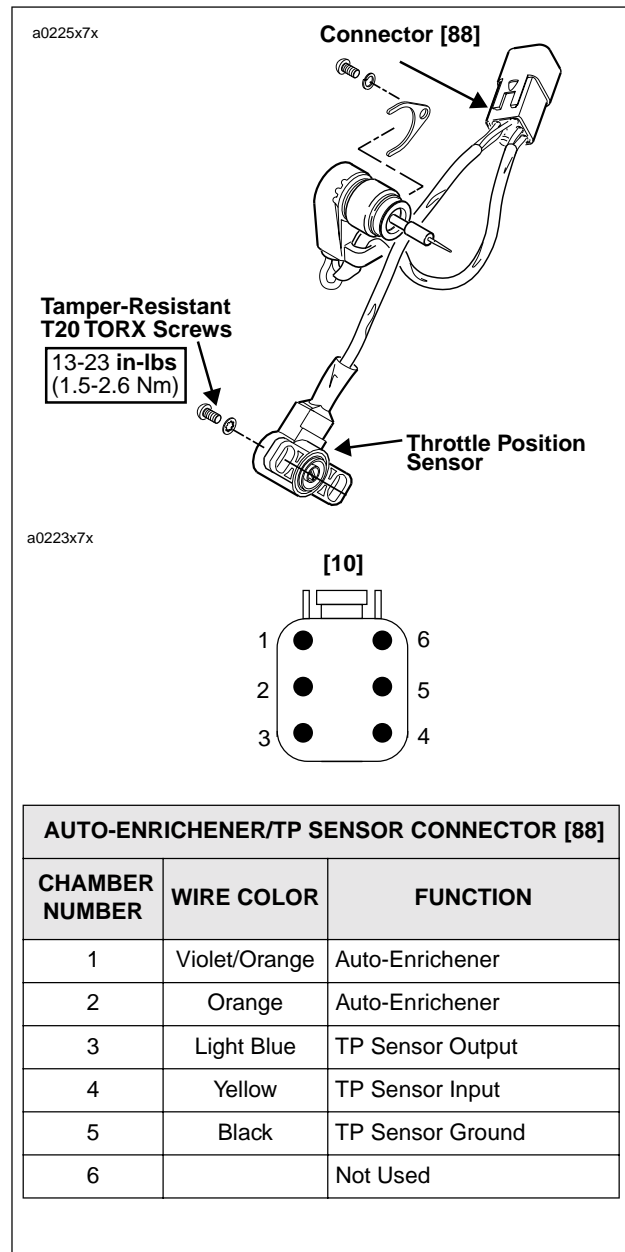

Figure 7-10. Throttle Position Sensor

MODEL YEAR CHANGE

All 2001 Blast P3 Model Buell motorcycles come equipped with a Bank Angle Sensor. The Bank Angle Sensor is located under the seat, behind the circuit breaker. The bank angle sensor turns off the ignition power should the bike lean angle exceed 55 degrees.

REMOVAL

1. Remove seat. See 2.29 SEAT.

WARNING

To protect against shock and accidental start-up of vehicle, disconnect the negative battery cable before proceeding. Inadequate safety precautions could result in death or serious injury.

2. Disconnect negative battery cable from battery.
3. See Figure 7-11. Remove circuit breaker from mounting bracket.
4. Remove allen head screw from mounting bracket while holding locknut on Bank Angle Sensor side.
5. Remove Bank Angle Sensor from it's mounting location.
6. Disconnect connector [134] from Bank Angle Sensor.
7. Remove Bank Angle Sensor.

INSTALLATION

1. Connect connector [134] to **new** Bank Angle Sensor.
2. See Figure 7-12. Position Bank Angle Sensor in mounting position on circuit breaker bracket mounting screw. Make sure sensor locating post engages hole in trunk to ensure proper alignment of sensor.
3. Install Bank Angle Sensor with allen screw and locknut. Tighten screw to 25-27 **in-lbs** (2.8-3.1 Nm).
4. Install circuit breaker to circuit breaker mounting bracket.
5. Install negative battery cable to battery terminal. Tighten fastener to 60-96 **in-lbs** (6.8-10.9 Nm).
6. Install seat. See 2.29 SEAT.

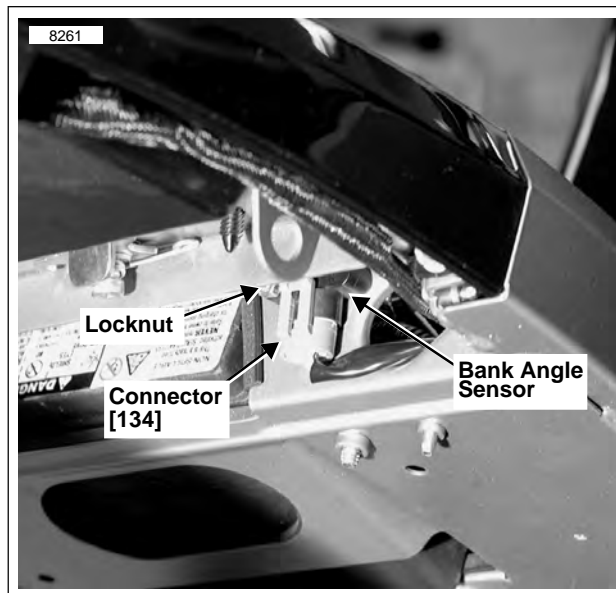

Figure 7-11. Bank Angle Sensor Removal

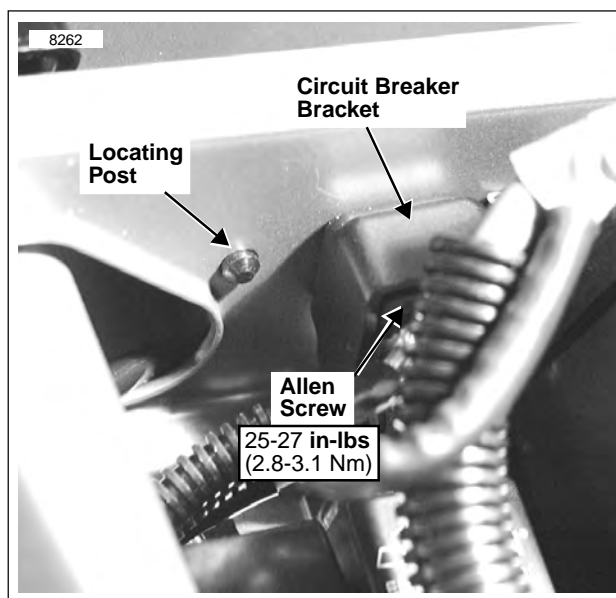

Figure 7-12. Bank Angle Sensor Installation

GENERAL

WARNING

DO NOT modify the ignition/headlamp switch wiring to circumvent the automatic-on headlamp feature. Visibility is a major concern for motorcyclists. Failure to have proper headlamp operation could result in death or serious injury.

See [Figure 7-13](#). The four-position combination ignition/headlamp key switch is not repairable. Replace the unit if it fails.

Switch positions are explained in the table below.

CAUTION

When turning off the ignition, verify that the key is removed in the OFF or FORK LOCK position and that the lights are not left on. If the rider stops the engine and inadvertently removes the key in the PARK position, the battery will be drained of its charge if the vehicle is left standing too long.

NOTE

The key locks the ignition system and is removable in both the OFF, FORK LOCK and P (PARK) positions. The PARK position is located between the OFF and IGNITION positions and allows the rider to remove the key while leaving the lights on. When the key is placed in the PARK position, several indicator markers are or can be activated. See the table to the right

REMOVAL

1. Remove seat. See [2.29 SEAT](#).

WARNING

To protect against shock and accidental start-up of vehicle, disconnect the negative battery cable before proceeding. Inadequate safety precautions could result in death or serious injury.

2. Disconnect negative battery cable from battery terminal.
3. Remove four screws and washers to detach windscreen from mounting brackets. See [2.27 WINDSCREEN](#).
4. See [Figure 7-14](#). Cut cable tie and disconnect ignition key switch connector [33] from main wiring harness. Note location of cable tie.
5. Remove two headlight bucket bolts and headlamp bucket. See [7.17 HEADLAMP](#).
6. Remove two bolts and ignition key switch.

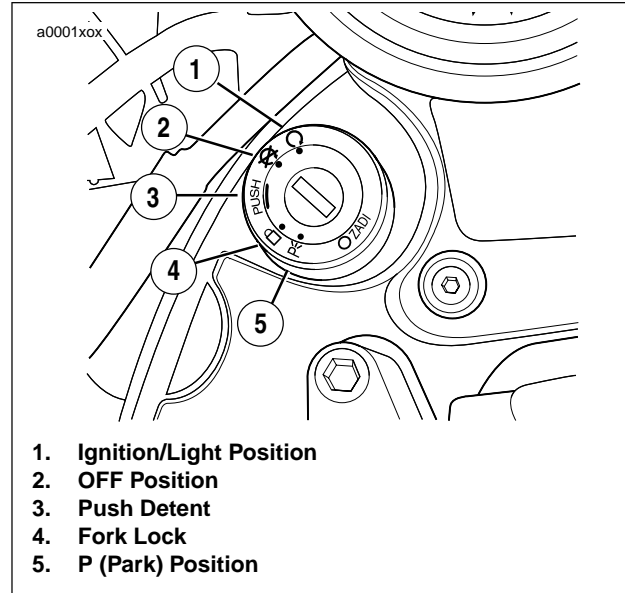

Figure 7-13. Ignition/Headlamp Key Switch

LABEL	NAME	IGN.	LAMPS	REMOVE KEY
OFF	Off	off	off	yes
	ForkLock	off	off	yes
P	Park	off	See note & the table below.	yes
IGN	Ignition	on		no

ITEM	P	IGN
Headlamp High/Low Beam	off	on
Speedometer Illumination Lamp	on	on
Stop Lamp	can be activated	
Front and Rear Turn Signals	can be activated	
Horn	can be activated	

INSTALLATION

1. Apply LOCTITE THREADLOCKER 243 (Blue) to threads of two ignition key switch bolts.
2. Install ignition key switch into hole and secure with two bolts. Tighten bolts to 4-6 ft-lbs (5.4-8 Nm).
3. See [Figure 7-14](#). Attach ignition key switch connector [33] to main wiring harness. Secure harness with cable tie.
4. Install headlight bucket with two bolts. Tighten bolts to 12-14 ft-lbs (16-19 Nm).
5. Cable tie ignition key switch connector [33] to main wiring harness.
6. Install four screws and washers to attach windscreen to mounting brackets. See [2.27 WINDSCREEN](#).
7. Install negative battery cable to battery terminal. Tighten fastener to 60-96 **in-lbs** (6.8-10.9 Nm).

⚠ WARNING

After installing seat, pull upward on front of seat to be sure it is locked in position. If seat is loose, it could shift during vehicle operation and startle the rider, causing loss of control of vehicle and result in death or serious injury.

8. Install seat. See [2.29 SEAT](#).

⚠ WARNING

Check for proper headlamp operation before riding motorcycle. Visibility is a major concern for motorcyclists. Failure to have proper headlamp operation could result in death or serious injury.

9. Check ignition key switch for proper operation. If operation fails, reread procedure and verify that all steps were performed.
 - a. Turn ignition key switch to OFF. Check all functions listed in the table on [page 5-14](#).
 - b. Turn ignition key switch to IGN. Start motorcycle. See Section 4.
 - c. Turn ignition key switch to LOCK.

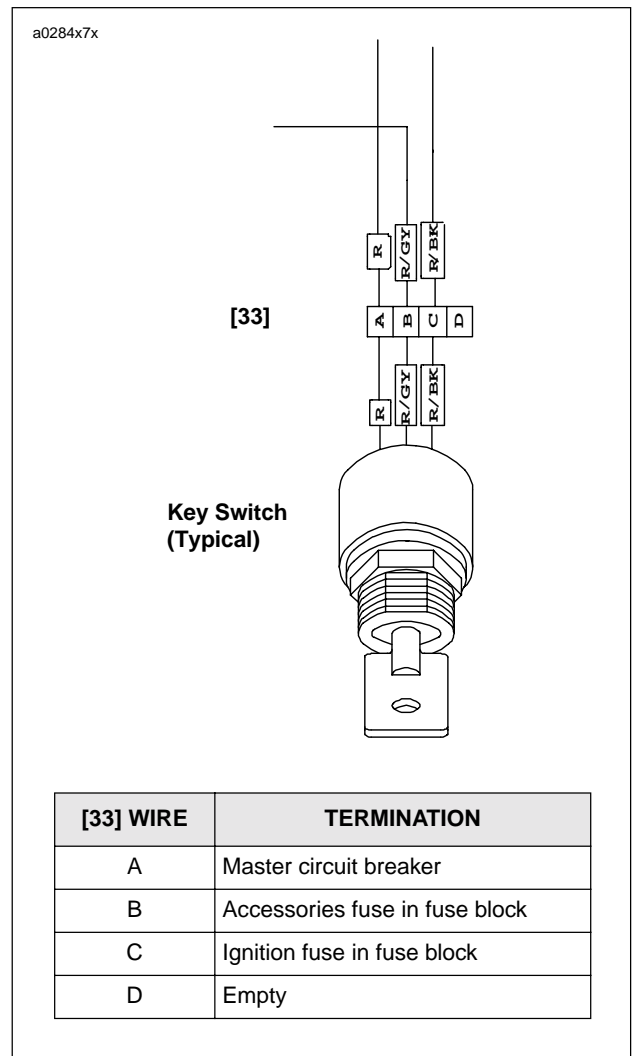

Figure 7-14. Ignition Key Switch Connector [33]

GENERAL

See [Figure 7-15](#). The auto enricher controls the cold idle speed of the motorcycle at startup and enriches the air/fuel mixture. It is located on the carburetor. The auto enricher is not repairable. Replace the unit if it fails.

NOTE

In extreme cold ambient conditions, auto-enricher may remain on for longer periods of time.

Normal function of the auto enricher is typically 2-5 minute fast idle speed enrichment cycle, even after hot restart. If enrichment cycle exceeds 5 minutes, see diagnostic chart on following page.

See [4.5 AUTO-ENRICHER](#) for information on replacing the auto enricher.

See diagnostic chart on next page for troubleshooting information.

NOTE

Auto-Enricher wire colors may vary from those listed in [Figure 7-15](#).

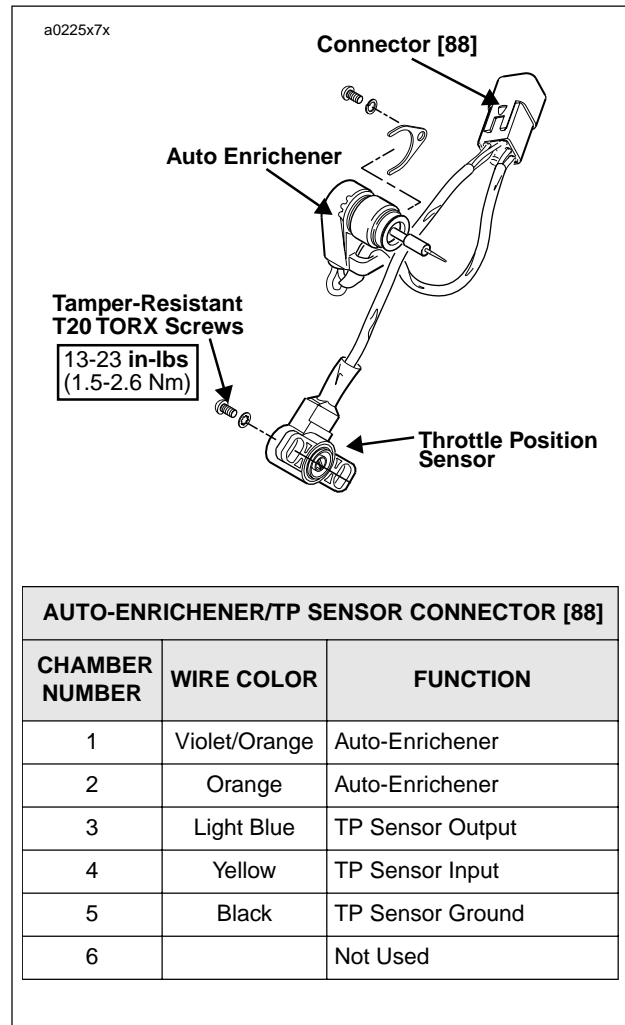

Figure 7-15. TP Sensor/Auto-Enricher Connector [88]

DRIVABILITY TROUBLESHOOTING

Idle Speed Incorrect

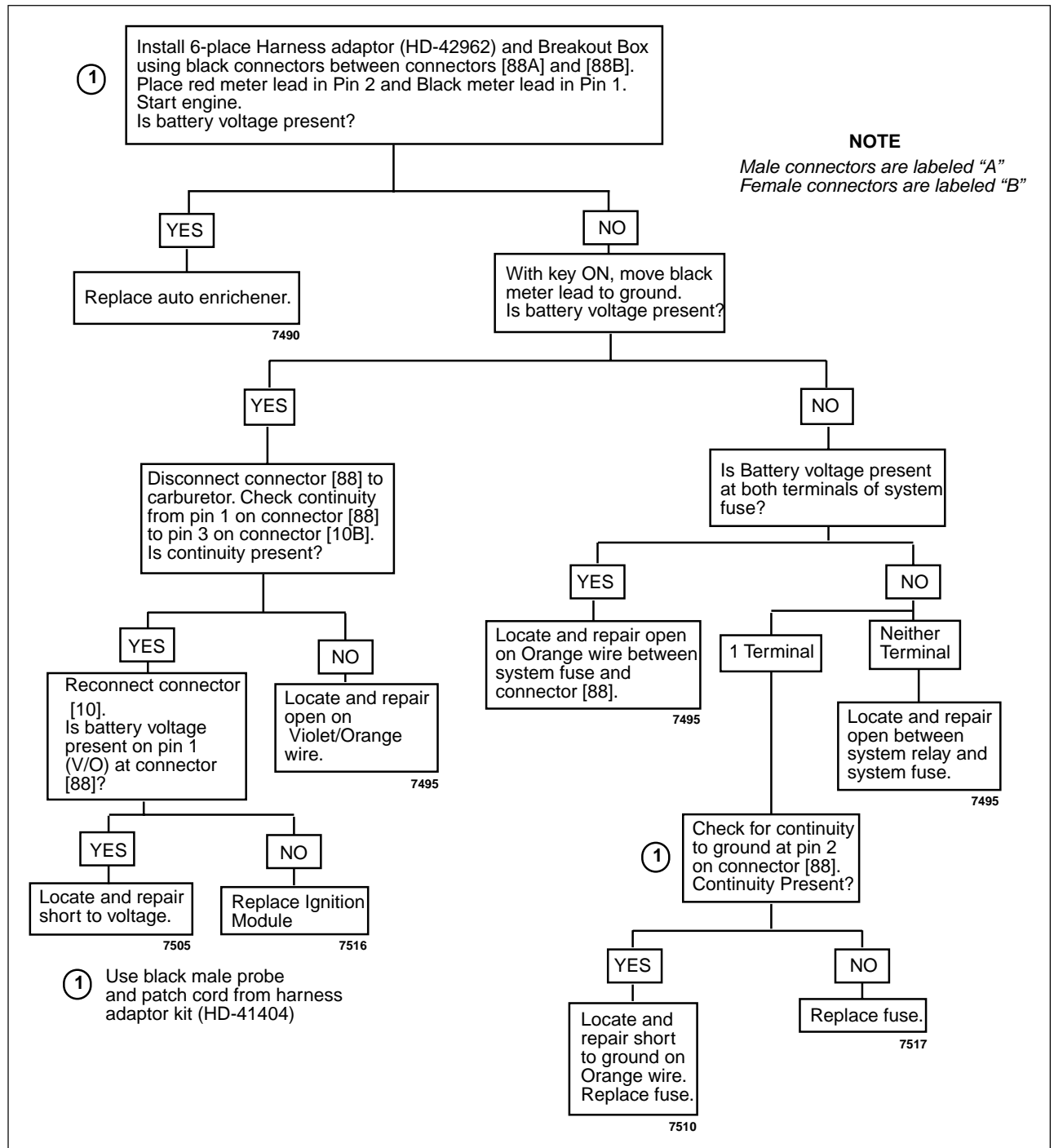

Figure 7-16. Driveability Troubleshooting

GENERAL

See [Figure 7-17](#). The ignition module is integrated with the cam position sensor on the module plate in the gearcase cover located on the right side of the motorcycle. The integrated ignition module is not repairable. Replace the unit if it fails.

See [7.2 IGNITION SYSTEM](#) for information on the function and testing of the integrated ignition module.

See [Figure 7-18](#). The rotor cup is located in the gearcase cover on the right side of the vehicle behind the integrated ignition module. The rotor is mounted on the camshaft and operates at one-half crankshaft speed. See [IGNITION TIMING](#) for information on the function, testing and adjustment of the integrated ignition module and trigger rotor assembly.

REMOVAL

1. Remove seat. See [2.29 SEAT](#).

WARNING

To protect against shock and accidental start-up of vehicle, disconnect the negative battery cable before proceeding. Inadequate safety precautions could result in death or serious injury.

2. Disconnect negative battery cable from battery terminal.
3. Remove locknut and clamp that secures wire harness and hoses on right side of motorcycle.
4. See [Figure 7-17](#). Disconnect connector [10] located on the left side of the frame backbone.
5. Note position of each wiring terminal in plug end of connector.
6. Remove connector terminal pins. See [B.2 DEUTSCH ELECTRICAL CONNECTORS](#).

WARNING

Always wear proper eye protection when drilling. Flying debris could result in serious eye injury.

CAUTION

Drilling hole in cover in location other than that specified may result in module plate damage. Drill carefully only where indicated to avoid damaging module plate behind cover.

CAUTION

Do not pry timer cover from bore or damage to gearcase or ignition module may result.

7. See [Figure 7-18](#). Drill hole in outer timer cover at 5:00 position approximately 1/2 inch (13 mm) in from outside edge. Pull out outer timer cover using 90 degree pick or other suitable tool.

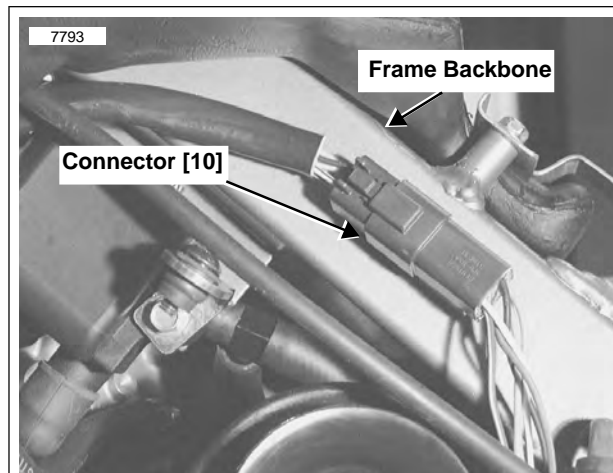

Figure 7-17. Integrated Ignition Module Connector [10]

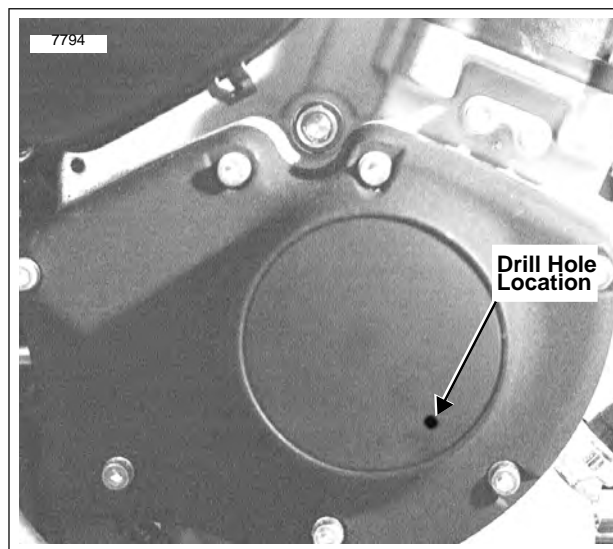

Figure 7-18. Drilling/Removing Timer Cover

8. To obtain approximate ignition timing during installation, scribe alignment marks across module plate and bore in two places.
9. See [Figure 7-19](#). Remove two module plate mounting screws. Carefully remove module plate. Remove screw and rotor cup.
10. Carefully remove camshaft oil seal if damaged or if there is any evidence of oil leakage past the seal.

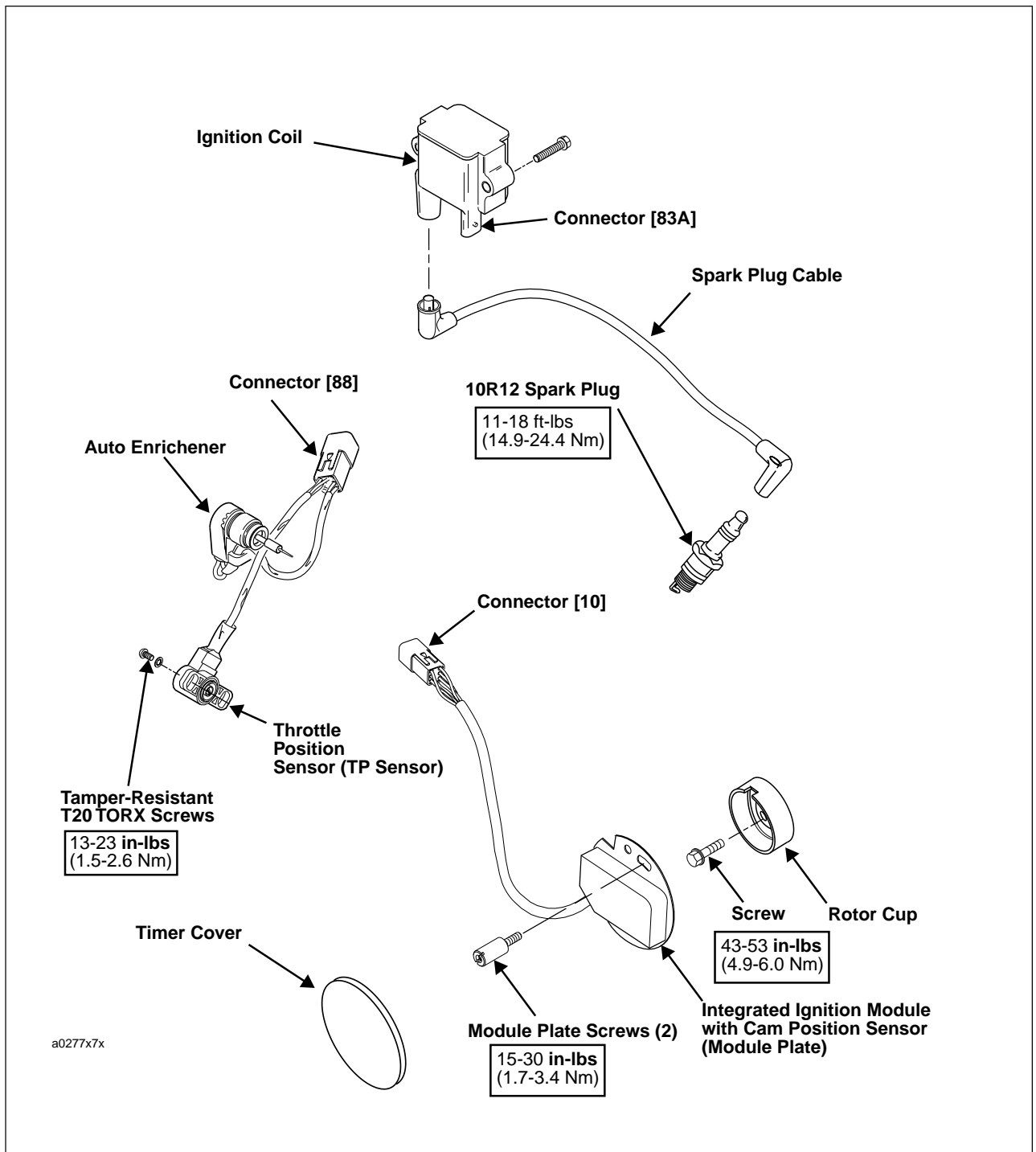

Figure 7-19. Ignition Module/Cam Position Sensor

INSTALLATION

1. With the lipped side facing inboard, install **new** camshaft oil seal into gearcase cover, if removed. Press seal into position until lightly bottomed.
2. Install rotor cup.
 - a. Apply LOCTITE THREADLOCKER 243 (blue) to threads of screw.
 - b. Position rotor cup onto end of camshaft aligning notch with camshaft slot.
 - c. Install screw to secure rotor cup. Tighten screw to 43-53 **in-lbs** (4.9-6.0 Nm).
3. Install module plate with two screws.
4. Install ignition module wiring terminals into correct positions in plug end of connector [10]. See Wiring Diagram. Install pin terminals. See [B.2 DEUTSCH ELECTRICAL CONNECTORS](#).
5. See [Figure 7-17](#). Mate connector [10] and install to T-stud on frame backbone.
6. Install locknut to clamp that secures hoses and wire harness on right side of motorcycle.
7. Install module plate with two screws. Do not tighten screws.
8. Install negative battery cable to battery terminal. Tighten fastener to 60-96 **in-lbs** (6.8-10.9 Nm).
9. Check ignition timing. See [IGNITION TIMING](#).
10. Tighten module plate screws to 15-30 **in-lbs** (1.7-3.4 Nm).
11. Install **new** outer timer cover.

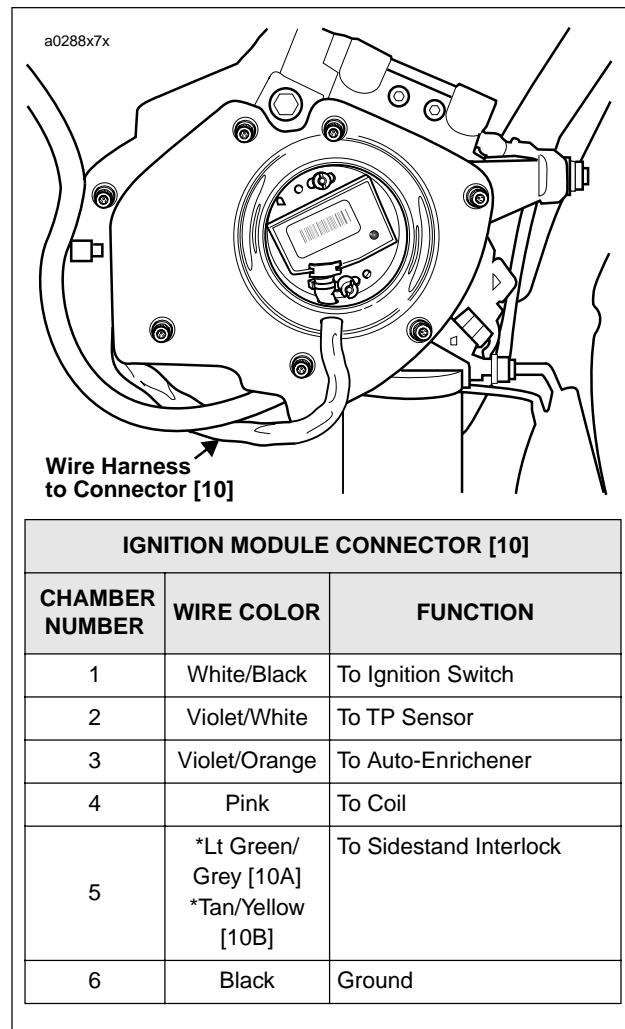

Figure 7-20. Ignition Connector [10]

IGNITION TIMING

NOTE

Use static timing method if inductive timing light is not available.

Dynamic Timing

1. Remove hex socket timing plug from timing inspection hole, which is located on right crankcase half and centered below engine cylinders. Install TIMING MARK VIEW PLUG (Part No. HD-96295-65D) into timing inspection hole. Make sure view plug does not touch flywheel.
2. Connect leads of INDUCTIVE TIMING LIGHT (Part No. HD-33813) to spark plug cable, battery positive (+) terminal, and suitable ground.
3. Make sure vacuum hose is properly installed at carburetor. Start engine.
4. Make sure sidestand is up and transmission is in NEUTRAL.
5. Set engine speed to 1200 rpm.

CAUTION

When checking ignition timing, always check at the rpm listed. Failure to do so may result in running engine with too much spark advance, and may cause extreme engine knock and engine failure.

6. See [Figure 7-21](#). Timing light will flash each time an ignition system spark occurs. Aim timing light into timing inspection hole. The advance timing mark (two dots) should be centered in timing inspection hole. If this is the case, ignition timing is properly adjusted. Go to Step 11. If timing mark is not centered or is not visible in the timing inspection hole, see to Steps 7-12.
7. See [Figure 7-18](#). Drill hole in location shown and remove outer timer cover, if not removed.
8. Loosen module plate screws just enough to allow sensor plate to be rotated using a screwdriver in the plate's notch.
9. With timing light aimed into inspection hole, rotate module plate until advance timing mark is centered in timing inspection hole (as shown in [Figure 7-21](#)).
10. See [Figure 7-18](#). Tighten module plate screws to 15-30 **in-lbs** (1.7-3.4 Nm)
11. Install **new** outer cover, if removed.
12. Remove TIMING MARK VIEW PLUG from timing inspection hole. Install hex socket timing plug. Torque timing plug to 10-15 ft. lbs (14-20 Nm).

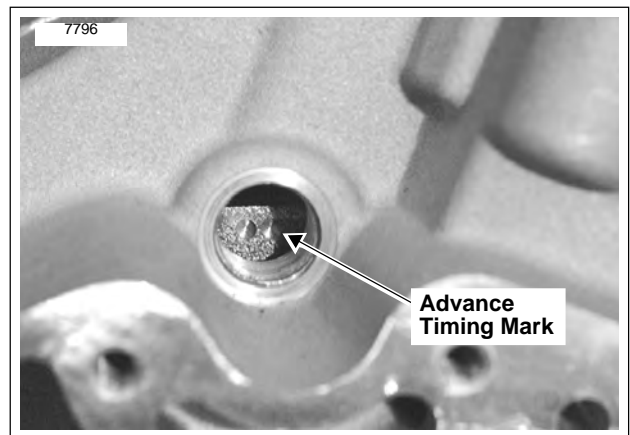

Figure 7-21. Dynamic Ignition Timing

Static Timing

NOTE

The outer timer cover is tamper-resistant and must be drilled out. A **new** outer timer cover will be required when doing this procedure. Do not reuse timer cover after hole has been drilled in it.

1. See Figure 7-22. Locate outer timer cover at bottom of gearcase cover on right side of vehicle.

WARNING

Always wear proper eye protection when drilling. Flying debris could result in serious eye injury.

2. See Figure 7-18. Drill hole in outer timer cover at 5:00 position approximately 1/2 inch (13 mm) in from edge. Pull out outer timer cover using 90 degree pick or other suitable tool.
3. Remove the timing plug from the timing inspection hole centered below the cylinder on the right side of the crankcase.
4. Remove the spark plug.
5. Jack up or hoist vehicle to allow rotation of the rear wheel.

NOTE

To check for intake valve closing place a finger over the spark plug hole opening. While engine is on compression stroke, air will be expelled from hole. When air is no longer expelled from hole, both valves are closed and engine should be close to TDC and between compression and power stroke.

6. Shift transmission into fifth gear, and standing on **left** side of vehicle, slowly rotate rear wheel in direction of forward motion (counter-clockwise) until front intake valve opens and closes.
7. See Figure 7-22. Rotate rear wheel from **right** side of vehicle in direction of forward motion (clockwise) until TDC mark (vertical line) is centered in timing inspection hole.
8. Turn ignition switch to ON position, make sure side stand is up and place transmission in NEUTRAL.
9. See Figure 7-23. Loosen two screws and slowly rotate module plate until red LED illuminates. Tighten module plate screws to 15-30 **in-lbs** (1.7-3.4 Nm) when complete.
10. Install **new** outer cover.
11. Install timing plug. Tighten plug to 10-15 ft-lbs (14-21 Nm).
12. If possible, dynamically time engine as well to verify that system is functioning properly. See DYNAMIC TIMING. Begin at step 2.

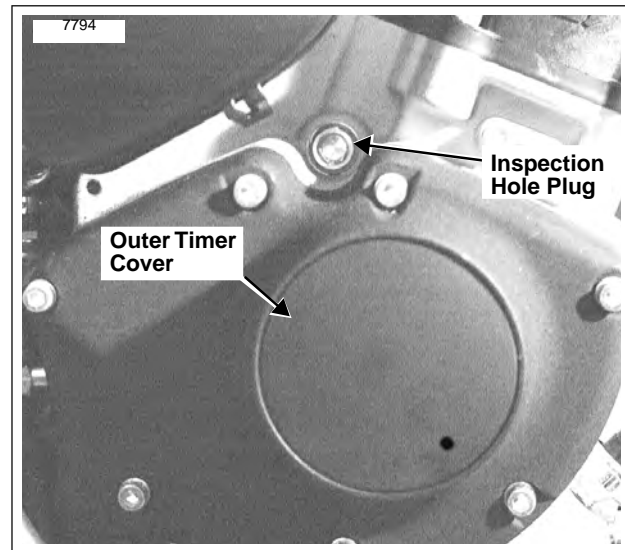

Figure 7-22. Timer Cover and Inspection Hole

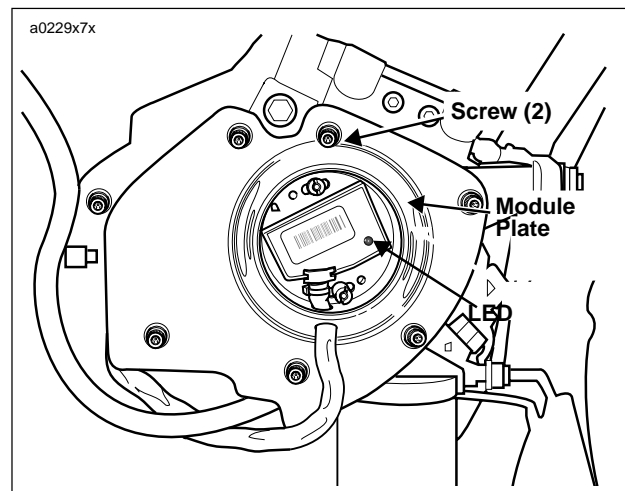

Figure 7-23. Static Ignition Timing (Typical)

GENERAL

See [Figure 7-24](#). The ignition coil is mounted on the frame underneath the fuel tank on left side above airbox.

See [Figure 7-18](#). The ignition coil is a pulse-type transformer. Internally, the coil consists of primary and secondary windings with a laminated iron core. The contents are sealed in a waterproof insulating compound. The ignition coil is not repairable. Replace the unit if it fails.

The low-voltage ignition primary circuit consists of the coil primary winding, ignition module and battery. When the circuit is closed, current flows through the coil primary winding creating a strong magnetic field in the iron core of the ignition coil.

When the ignition module receives a signal from the cam position sensor and trigger rotor, the ignition module interrupts (opens) the ignition primary circuit, which causes the magnetic field in the coil core to collapse.

The collapsing magnetic field induces a high-voltage electrical discharge in the ignition secondary circuit, which consists of the coil secondary winding, spark plug cable and spark plug. The high-voltage discharge produces a spark to bridge the electrode gap of the spark plug.

The ignition coil fires the spark plug at the end of the compression stroke (no-waste spark).

TROUBLESHOOTING

Follow the troubleshooting procedures listed under [7.8 IGNITION MODULE/ CAM POSITION SENSOR](#) if the engine will not start, is difficult to start or runs roughly. Also check condition of the spark plug cable. Insulation on cable may be cracked or damaged allowing high tension current to short to metal parts. This problem is most noticeable when cable is wet.

If poor starting/running condition persists, check resistance of ignition coil primary and secondary winding using an ohmmeter.

Ignition Coil Primary Circuit Test

1. Remove ignition coil.
2. Set ohmmeter scale to RX1.
3. See [Figure 7-25](#). Using harness connector adaptor kit (HD-41404) gray female probes and patch cord, place multimeter wires on primary coil windings. See Page 7-7.
4. Check for primary coil winding resistance.
 - a. Normal resistance range is 0.4-0.6 ohms.
 - b. See [TEST RESULTS](#) on the next page if resistance is not within normal operating range.

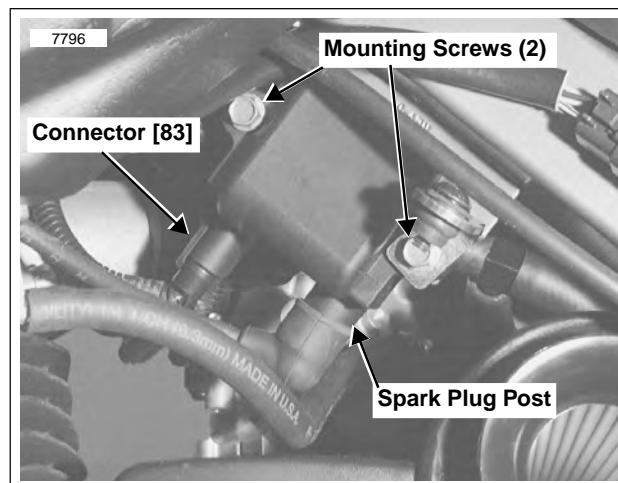

Figure 7-24. Ignition Coil (Left Side)

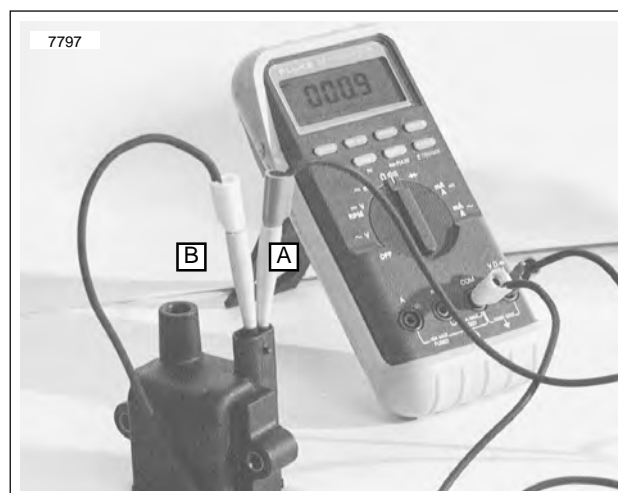

Figure 7-25. Ignition Coil Primary Resistance Test

Ignition Coil Secondary Circuit Test

1. Remove ignition coil.
2. Set ohmmeter scale to RX1K.
3. See [Figure 7-26](#). Using harness connector adaptor kit (HD-41404) gray female probes and patch cord, place multimeter wires on secondary coil windings. See Page 7-7.
4. Check for secondary coil winding resistance.
 - a. Normal resistance range is 7,720-9,440 ohms.
 - b. See [TEST RESULTS](#) on the next page if resistance is not within normal operating range.

Test Results

1. A low resistance value indicates a short in the coil winding. Replace coil.
2. A high resistance value might indicate that there is some corrosion/oxidation of the coil terminals. Clean the terminals and repeat resistance test. If resistance is still high after cleaning terminals, replace coil.
3. An infinite ohms (∞ or no continuity) resistance value indicates an open circuit (a break in the coil winding). Replace coil.

REMOVAL

1. Remove seat. See 2.29 SEAT.

WARNING

To protect against shock and accidental start-up of vehicle, disconnect the negative battery cable before proceeding. Inadequate safety precautions could result in death or serious injury.

2. Disconnect negative battery cable from battery terminal.
3. Remove fuel tank cover. See 4.2 FUEL TANK COVER/ FUEL TANK.
4. Remove left fascia.
5. See Figure 7-24. Disconnect spark plug cable from coil plug post.
6. See Figure 7-27. Disconnect coil connector [83].
7. Remove two screws and washers and coil.

INSTALLATION

1. See Figure 7-24. Apply LOCTITE THREADLOCKER 243 (Blue) to threads of two mounting screws.
2. Attach coil to frame with screws and washers (1). Tighten to 4-6 ft-lbs (5.4-8 Nm).
3. Attach coil connector [83].
4. Connect spark plug cable to ignition coil.
5. Attach left fascia.
6. Install negative battery cable to battery terminal. Tighten fastener to 60-96 in-lbs (6.8-10.9 Nm).
7. Install fuel tank cover. See 4.2 FUEL TANK COVER/ FUEL TANK.

WARNING

After installing seat, pull upward on front of seat to be sure it is locked in position. If seat is loose, it could shift during vehicle operation and startle the rider, causing loss of control of vehicle and death or serious injury.

8. Install seat. See 2.29 SEAT.

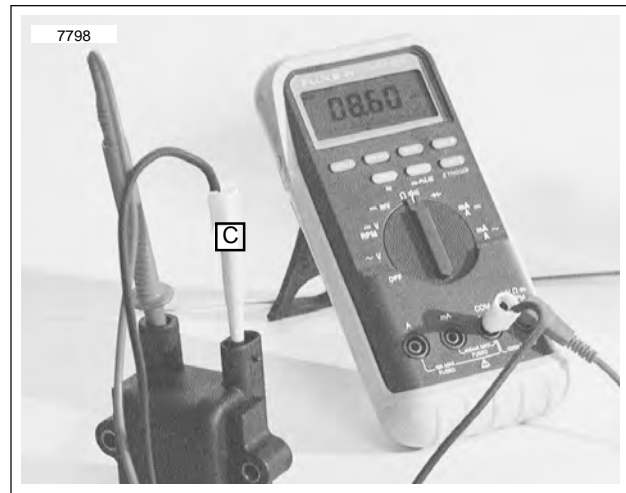
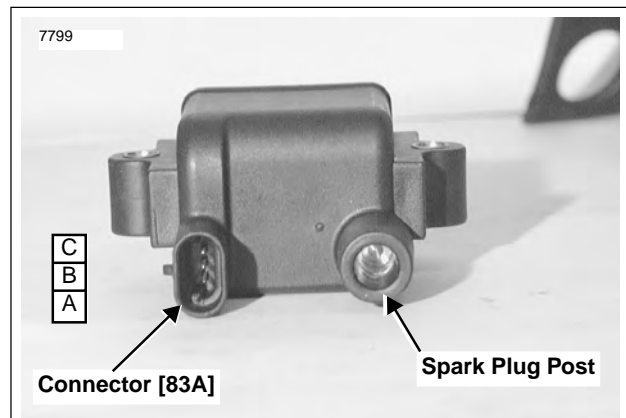

Figure 7-26. Ignition Coil Secondary Resistance Test



COIL CONNECTOR [83]		
CHAMBER NUMBER	WIRE COLOR	FUNCTION
A	White/Black	(+) To Right Handlebar Switch
B	Pink	(-) To Ignition Module
C	Black	Ground

Figure 7-27. Coil Viewed From Bottom

GENERAL

Resistor-type high-tension spark plug cables have a carbon-impregnated fabric core, instead of solid wire, for radio noise suppression and improved reliability of electronic components. Use the exact replacement cable for best results.

REMOVAL

⚠ WARNING

Never disconnect the spark plug cable with the engine running. If you disconnect the spark plug cable with the engine running, you may receive a severe electric shock from the ignition system which could result in death or serious injury.

CAUTION

When disconnecting the spark plug cable from its spark plug terminal, always grasp and pull on the rubber boot at the end of the cable assembly (as close as possible to the spark plug terminal). Do not pull on the cable portion itself. Pulling on the cable will damage the cable's carbon core.

Disconnect spark plug cable from ignition coil and spark plug terminal. Inspect removed cable for damage.

INSPECTION

1. See [Figure 7-28](#). Inspect spark plug cable. Replace cable if worn or damaged.
 - a. Check for cracks or loose terminals.
 - b. Check for loose fit on ignition coil and spark plug.
2. Check cable boot/cap for cracks or tears. Replace boot/cap if worn or damaged.
3. See [Figure 7-29](#). Check spark plug cable resistance with an ohmmeter. Replace cables not meeting resistance specifications.
 - 2,375-5,833 ohms

INSTALLATION

1. Connect spark plug cable to ignition coil and spark plug.
2. Fasten boot/cap securely. Tight connections provide the necessary moisture-proof environment for the ignition coil and spark plug terminals.

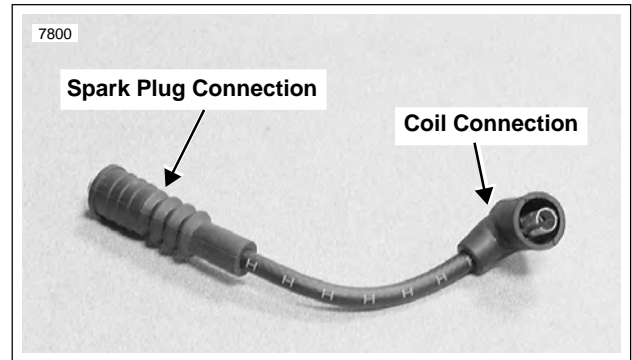
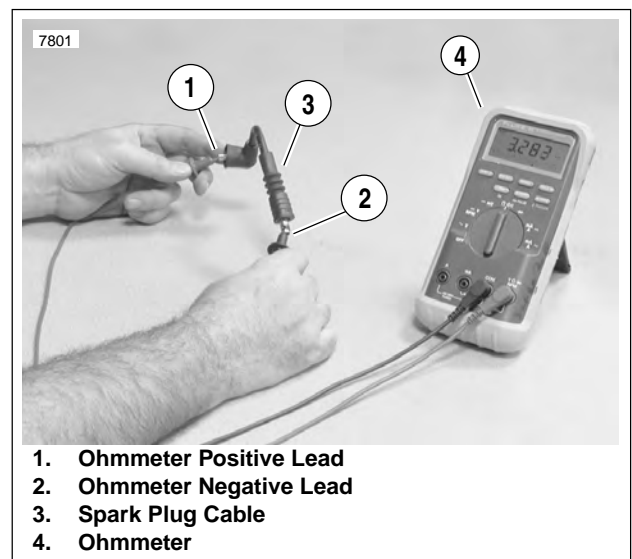

Figure 7-28. Spark Plug Cable (Typical)



1. Ohmmeter Positive Lead
2. Ohmmeter Negative Lead
3. Spark Plug Cable
4. Ohmmeter

Figure 7-29. Testing Resistance

GENERAL

The starter/ignition interlock system is designed to prevent unintended start-up and/or forward motion of the motorcycle. One of three conditions must exist to allow operation of the vehicle:

- Clutch disengaged (lever pulled in)
- Transmission in Neutral
- Sidestand retracted

VOLTAGE AT TNY WIRE AT CONNECTOR [10B]		
CONDITION	SIDESTAND DOWN	SIDESTAND UP
Clutch Engaged Transmission in Gear	<1.0V	12V (Battery Voltage)
Neutral	Battery Voltage minus 0.7V +/- 0.1V	12V (Battery Voltage)
Clutch Disengaged	Battery Voltage minus 0.7V +/- 0.1V	12V (Battery Voltage)

Starter Circuit

The starter circuit prevents the motorcycle from being started unless a ground has been established at the starter relay. This ground comes from one source.

- By disengaging the clutch (pulling in the clutch lever) and grounding through the clutch lever switch.

Once the starter circuit is grounded and the starter button pushed, the starter relay can be energized. The energized relay then allows the starter motor to crank the engine.

Ignition Circuit

The ignition circuit prevents the motorcycle from operating unless a ground is established at the system relay. If this ground is not established, the ignition system will not be turned on and the motorcycle will not run. Grounds may be established three ways.

- By retracting the side stand and grounding through the **side stand switch**. See Ignition Test 1 on following page to check sidestand switch function.
- By placing the motorcycle in neutral and grounding through the **neutral switch**. See Ignition Test 2 on following page to check neutral switch function.
- By disengaging the clutch and grounding through the **clutch lever switch**. See Ignition Test 3 on page 7-28 to check clutch switch function.

Note that the ignition circuit is enabled when the transmission is in gear with the side stand extended if the clutch is disengaged (clutch lever pulled in). However, if the motorcycle is in gear with the side stand extended, and the clutch lever is released, the ignition ground is lost and the ignition system is turned off. This system will prevent vehicle operation if forward motion is attempted with the side stand down.

See Ignition Tests on following pages.

Use harness connector adaptor kit (HD-41404) gray male probe and patch cord.

DIAGNOSTICS

Ignition Test 1 - Sidestand Switch Function

CONDITION: Sidestand up and key ON, transmission in neutral and clutch engaged

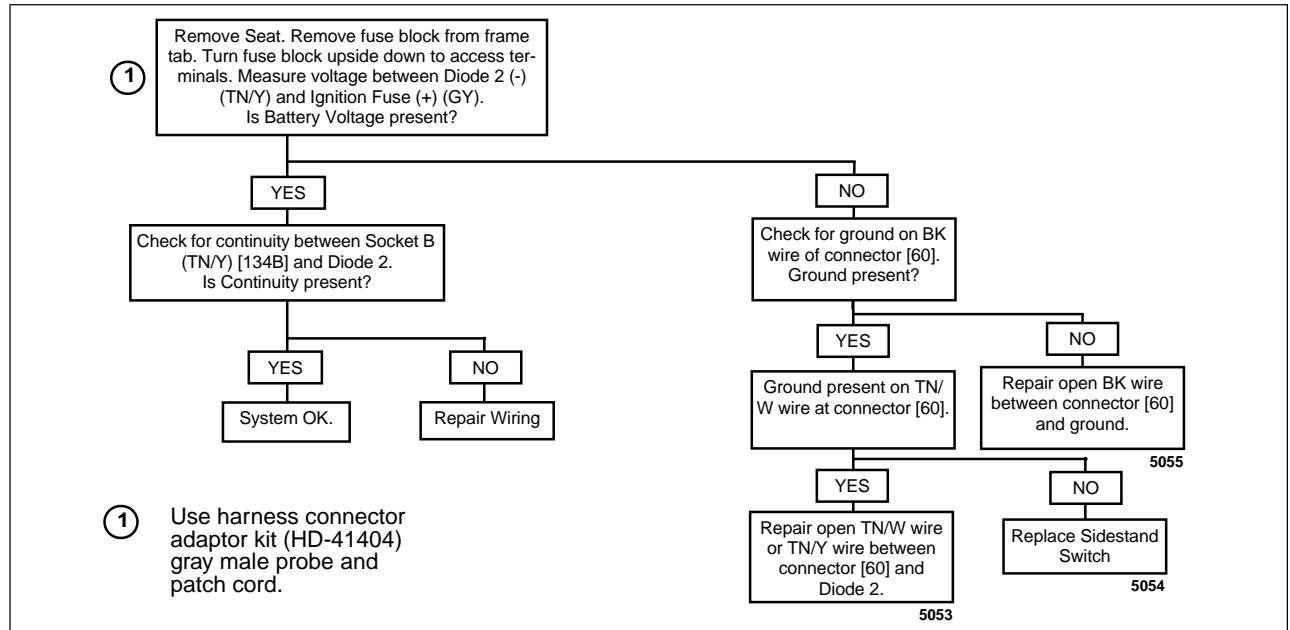

Figure 7-30. Ignition Test 1

Ignition Test 2 - Neutral Switch Function

CONDITION: Sidestand down, key ON, transmission in neutral and clutch engaged

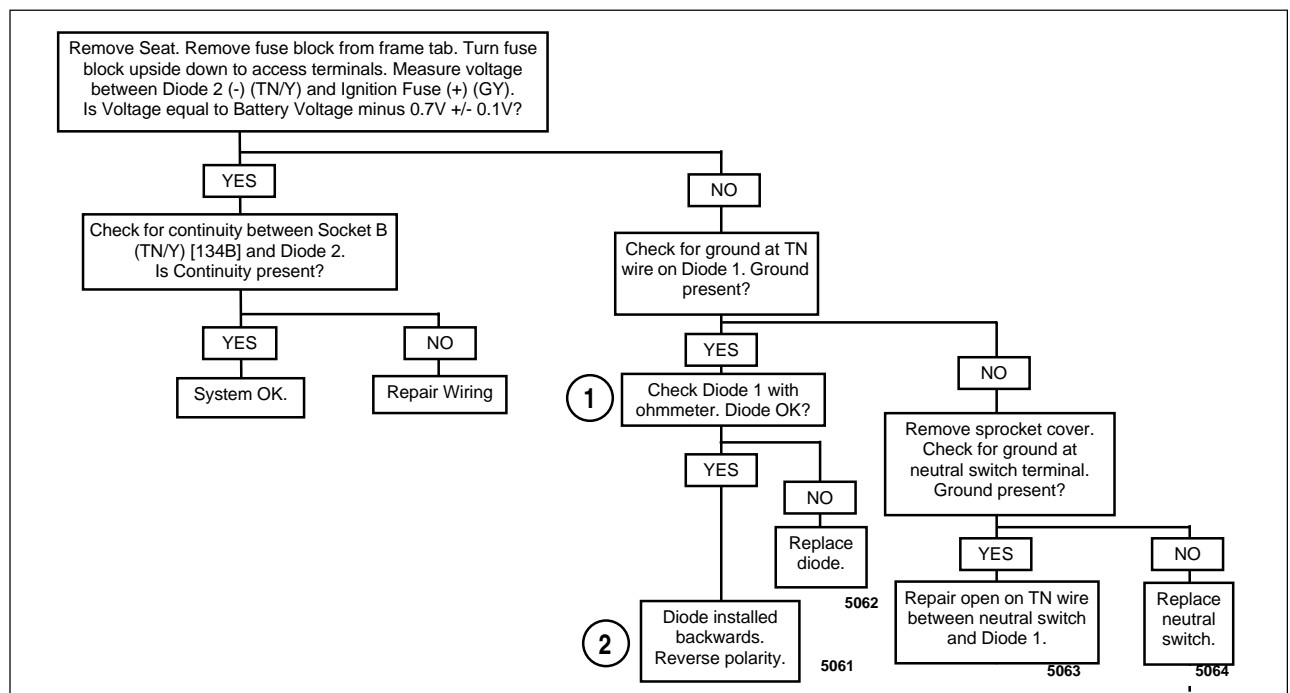

Figure 7-31. Ignition Test 2

Ignition Test 3 - Clutch Switch Function

CONDITION: Sidestand down, key ON, transmission in gear and clutch disengaged

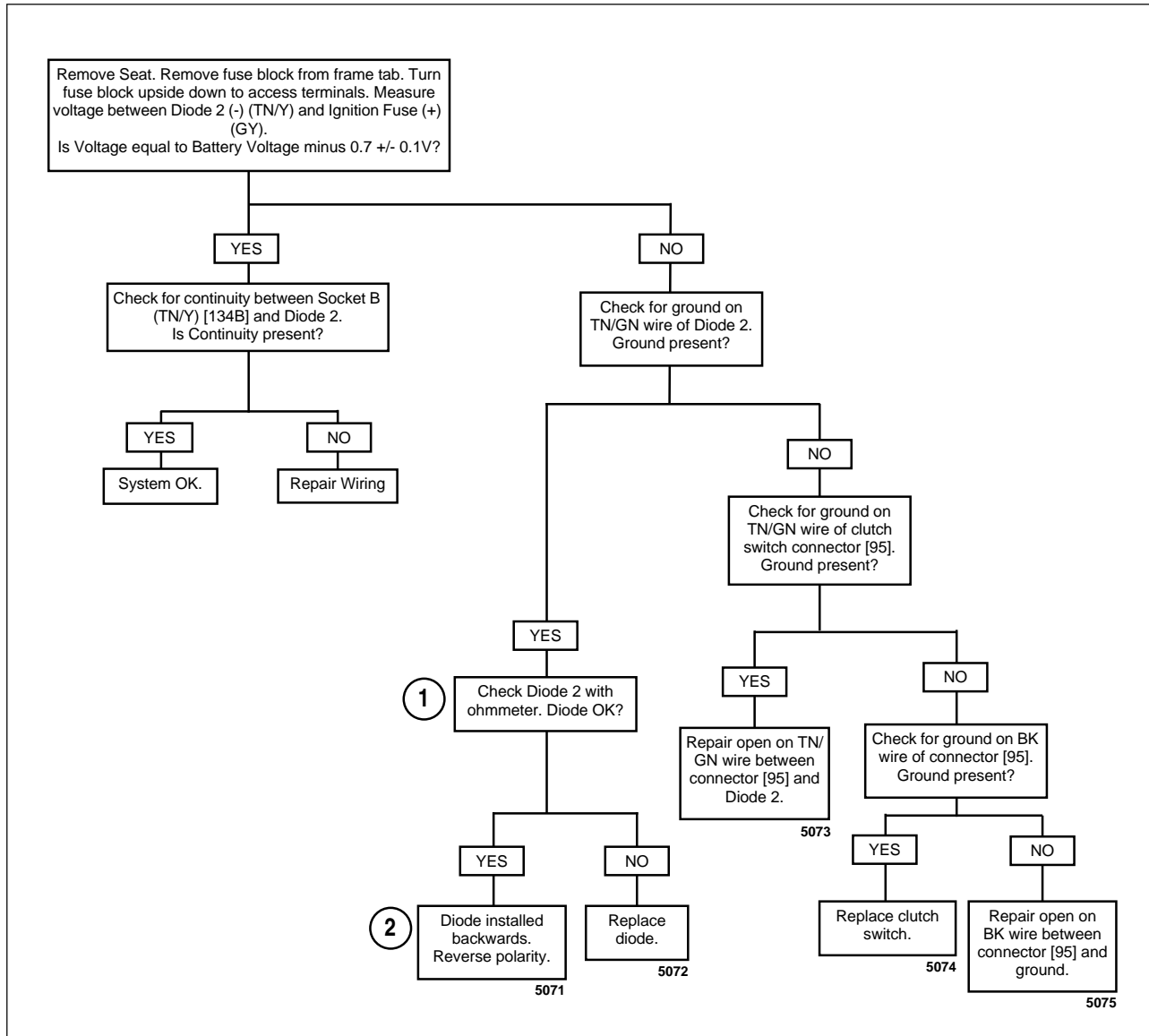
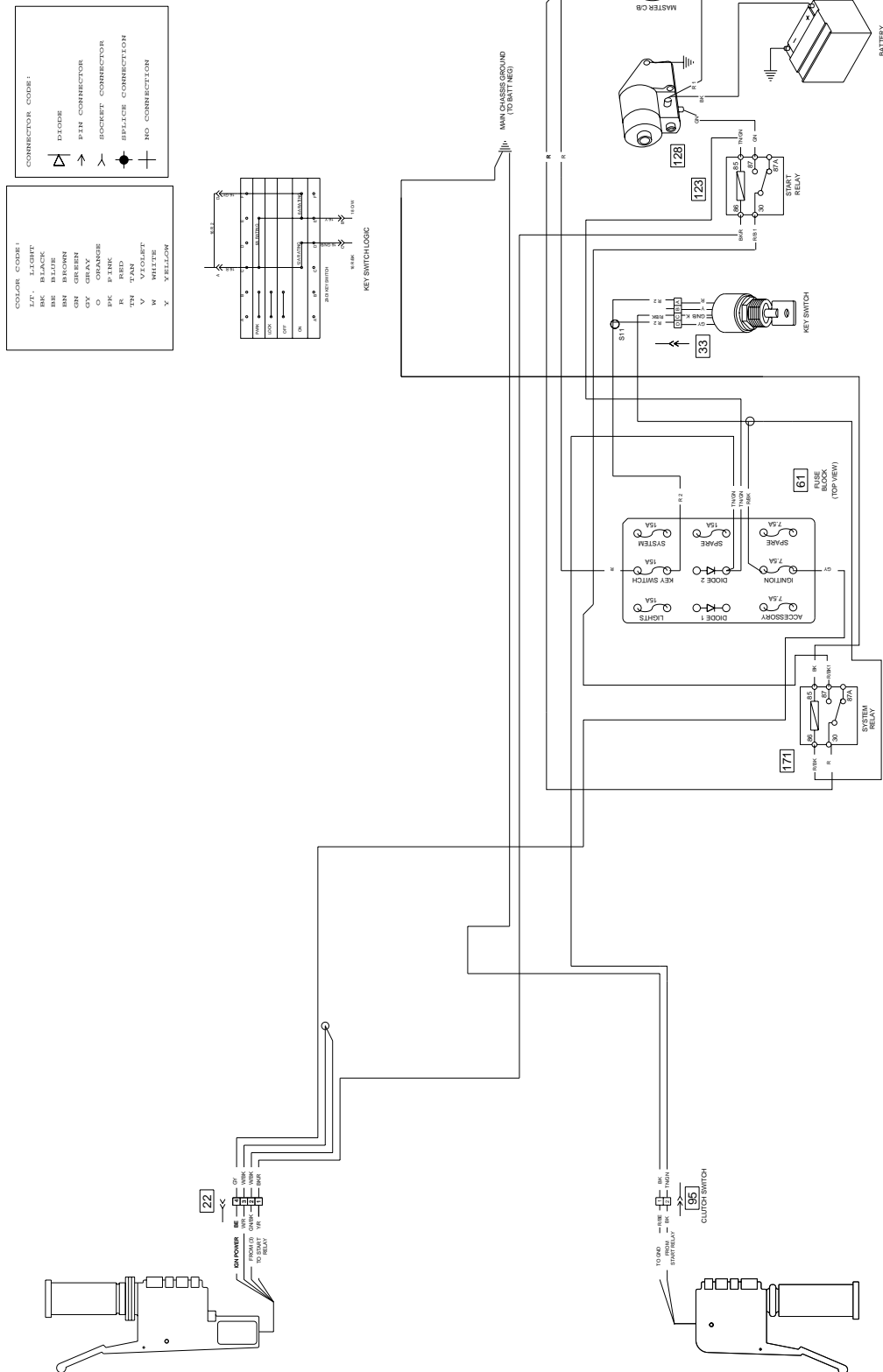

Figure 7-32. Ignition Test 3

a0194X5x



TESTING/REPLACEMENT

Side Stand Switch

See [Figure 7-33](#). The side stand switch is a simple spring loaded plunger. The switch completes a path to ground for the ignition relay when the side stand is in the retracted position. Test the switch as follows:

1. Unplug the 2-place side stand switch connector [60].
2. Test the switch using an ohmmeter.
 - a. With side stand down (switch open), the switch should show ∞ ohms (infinite ohms).
 - b. With side stand up (switch closed), the switch should show 0 ohms or little resistance.
3. Replace the assembly with a **new** switch if necessary.
 - a. Remove side stand switch from Sidestand by removing two bolts and nuts.
 - b. Apply LOCTITE THREADLOCKER 243 (Blue) to threads of two bolts.
 - c. Install **new** sidestand switch with two bolts and nuts. Tighten bolts to 30-36 **in-lbs** (3.3-4.1 Nm).

Clutch Switch

See [Figure 7-34](#). The clutch switch attaches to the clutch control lever bracket. The switch completes a path to ground for the ignition relay and the starter relay when the clutch is disengaged. Test the switch as follows:

1. Unplug the 2-place clutch switch connector [95].
2. Test the switch using an ohmmeter.
 - a. With clutch engaged (1) (switch open), the switch should show ∞ ohms (infinite ohms).
 - b. With clutch disengaged (2) (switch closed), the switch should show 0 ohms or little resistance.
3. Replace the assembly with a **new** switch if necessary.
 - a. Remove small Phillips screw.
 - b. Depress clutch lever and hold.
 - c. Detach switch by depressing switch trigger button and pulling switch towards the end of the handlebar.
 - d. Install **new** switch.

NOTE

To test/replace the neutral switch, see [7.23 NEUTRAL INDICATOR SWITCH](#).

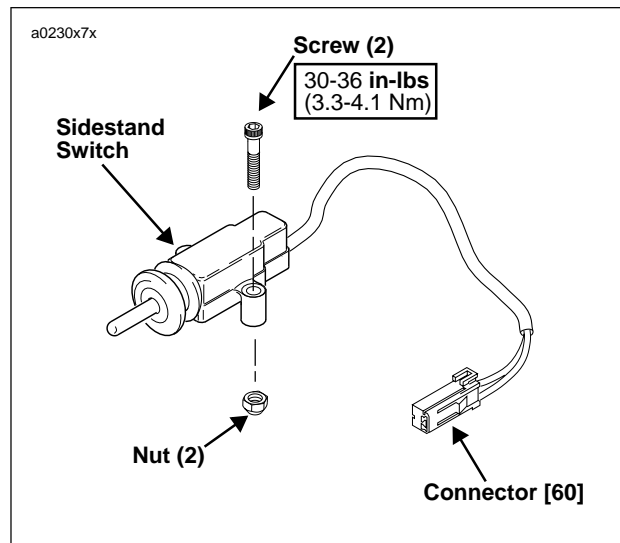

Figure 7-33. Side Stand Switch

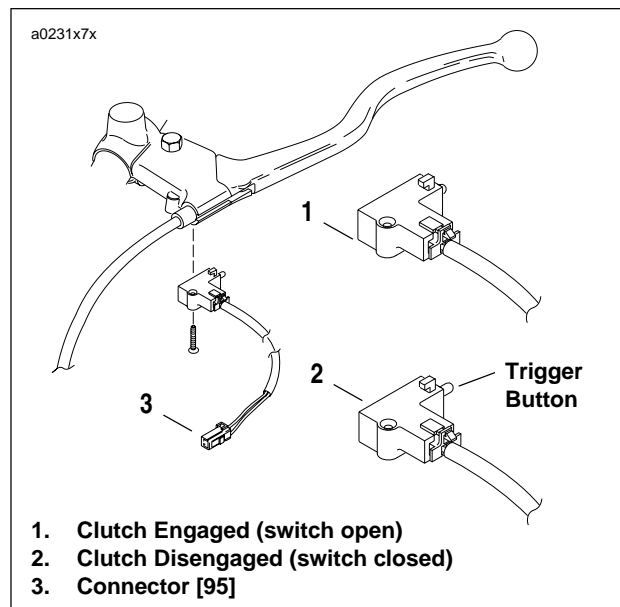

Figure 7-34. Clutch Switch

System Relay

See [Figure 7-35](#). The system relay is in the relay block which is located on the left side under the seat. Test the relay as follows:

1. Remove seat. See [2.29 SEAT](#).
2. Unplug relay from connector. See ["ON-MOTORCYCLE" TESTS](#).
3. Test the relay in the same fashion as the starter relay. See [5.6 STARTER SYSTEM TESTING](#).
4. Replace the relay with a **new** relay if necessary. Install relay to frame with new rivet and washer.

Starter Relay

The starter relay is located on the right side of the motorcycle, underneath the seat by the flasher relay.

Main Circuit Breaker

See [Figure 7-36](#). Attached to the frame above the battery, the main circuit breaker is between the ignition key switch and the battery. Remove the main circuit breaker as follows:

1. Remove seat. See [2.29 SEAT](#).
2. Disconnect battery negative cable from battery.
3. See [Figure 7-37](#). Remove acorn nuts, nuts with lock washers and wire leads from circuit breaker studs. Tag wire leads for ease of assembly.
4. See [Figure 7-36](#). Remove circuit breaker from circuit breaker bracket by carefully prying tab, located on left side, open and sliding circuit breaker out. NOTE: Bank Angle Sensor will require reinstallation if bracket is removed. See [7.5 BANK ANGLE SENSOR](#).
5. Install in the reverse order. Tighten screw (if bracket was removed) to 25-27 in-lbs (2.8-3.1 Nm). Tighten metal nut to 15-18 in-lbs (1.7-2 Nm). Tighten plastic acorn nuts to 1-3 in-lbs (0.1-0.3 Nm).

Ignition Fuse

See [Figure 7-38](#). The ignition fuse is in the fuse block under the seat. Always replace the fuse with another 7.5 ampere fuse.

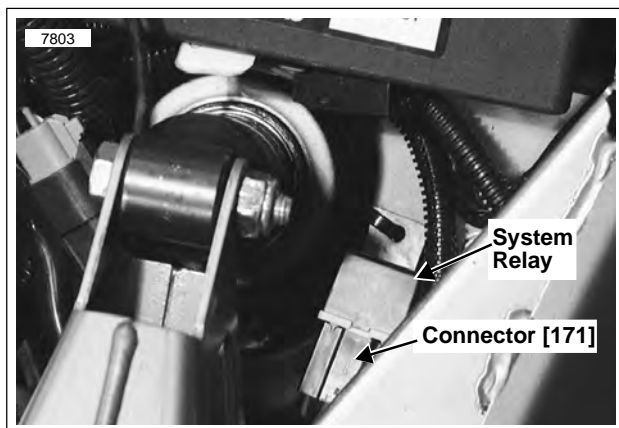

Figure 7-35. System Relay

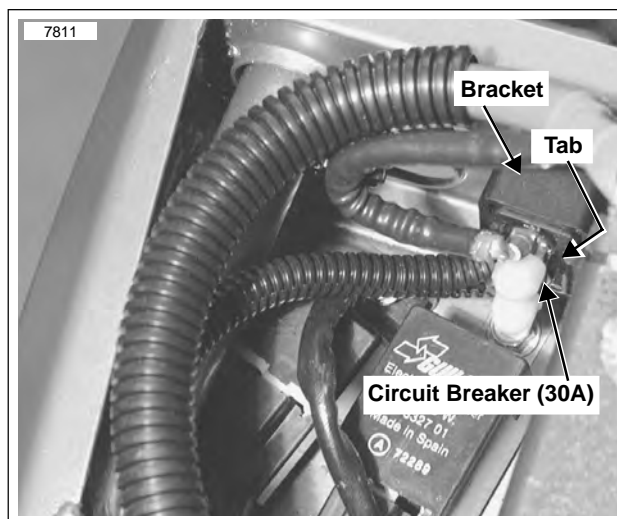

Figure 7-36. Circuit Breaker

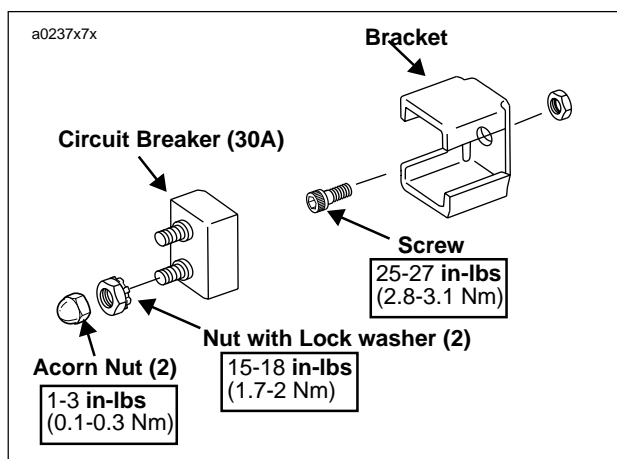

Figure 7-37. Circuit Breaker Installation

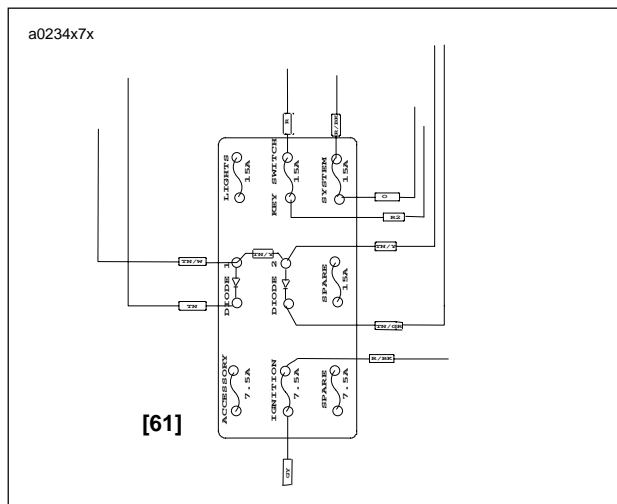

Figure 7-38. Fuse Block

Diodes

The relay block contains two diodes. A diode acts as a one way switch which permits current flow in one direction, but not in the other.

The reference numbers below correlate with the circled numbers in the 7.11 STARTER/IGNITION INTERLOCK flow charts.

1. Check diode with an ohmmeter as shown in Figure 7-39.
2. Check diode polarity as shown in Figure 7-40.
3. Replace diodes as necessary.

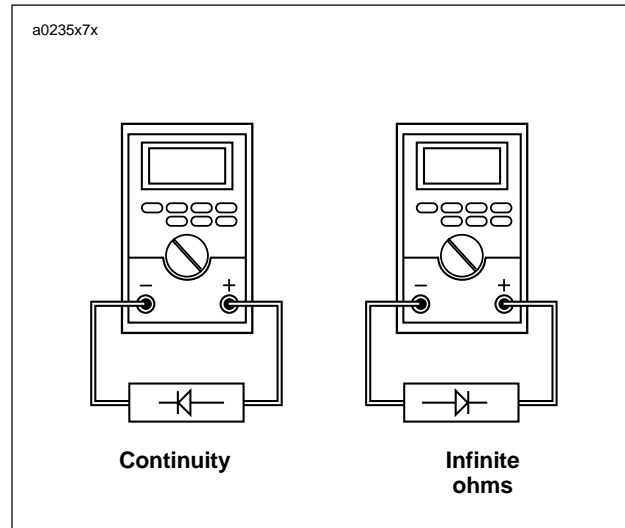

Figure 7-39. Ohmmeter Diode Test

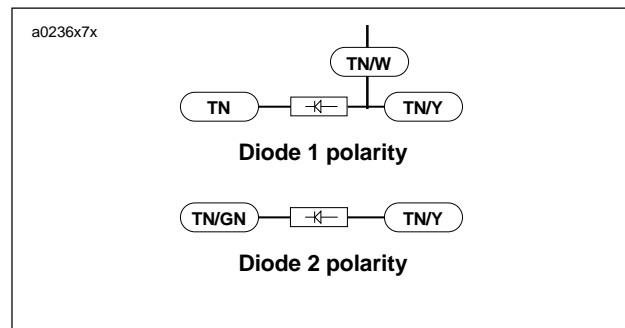

Figure 7-40. Diode Polarity

REMOVAL

1. Remove seat. See [2.29 SEAT](#).

⚠ WARNING

To protect against shock and accidental start-up of vehicle, disconnect the negative battery cable before proceeding. Inadequate safety precautions could result in death or serious injury.

6. Disconnect negative battery cable from battery.
7. See [Figure 7-42](#). Both diodes are mounted in the fuse block under the seat.
8. Remove faulty diode by pulling it straight up off the relay block.

INSTALLATION

1. See [Figure 7-42](#). Install the **new** diodes into position on the fuse block by pushing it into the slot.
2. Connect negative battery cable to battery terminal. Tighten fastener to 60-96 **in-lbs** (6.8-10.9 Nm).

⚠ WARNING

After installing seat, pull upward on front of seat to be sure it is locked in position. If seat is loose, it could shift during vehicle operation and startle the rider, causing loss of control of vehicle and death or serious injury.

3. Install seat. See [2.29 SEAT](#).

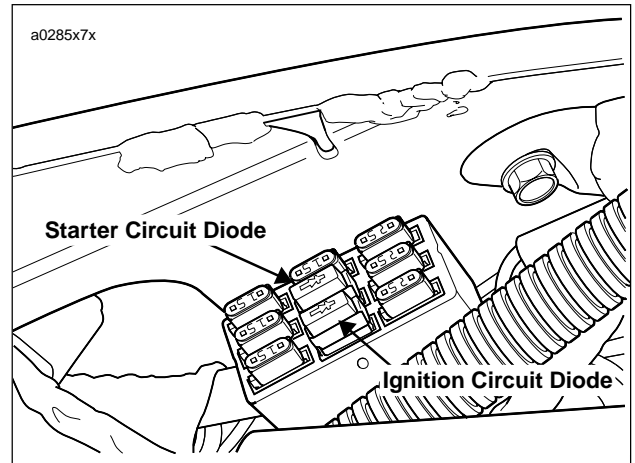

Figure 7-42. Diode Location in Fuse Block

GENERAL

The charging system consists of the alternator and regulator. Charging system circuits are shown in [Figure 7-45](#).

Alternator

The alternator consists of two main components:

- The rotor which mounts to the engine sprocket shaft.
- The stator which bolts to the engine crankcase.

Voltage Regulator

See [Figure 7-43](#). The voltage regulator is a series regulator with shunt control. The circuit combines the functions of rectifying and regulating.

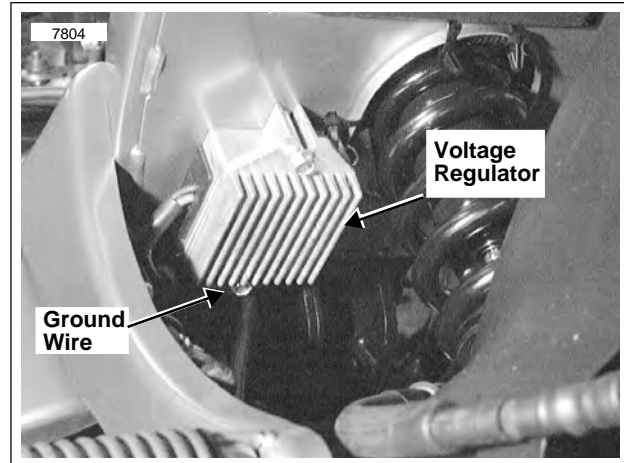

Figure 7-43. Voltage Regulator

TROUBLESHOOTING

When the charging system fails to charge or does not charge at a satisfactory rate, make the following recommended checks.

Battery

Check for a weak or dead battery. See [7.16 BATTERY](#). Battery must be fully charged in order to perform any electrical tests.

Wiring

Check for corroded or loose connections in the charging circuit. See [Figure 7-45](#).

Voltage Regulator Inspection

See [Figure 7-43](#). The voltage regulator base must have a clean, tight connection for proper grounding. The harness is grounded to the voltage regulator body. Check by using an ohmmeter with one lead on a known good ground, such as battery ground cable, and the other on the regulator base.

Connector plug to stator must be clean and tight.

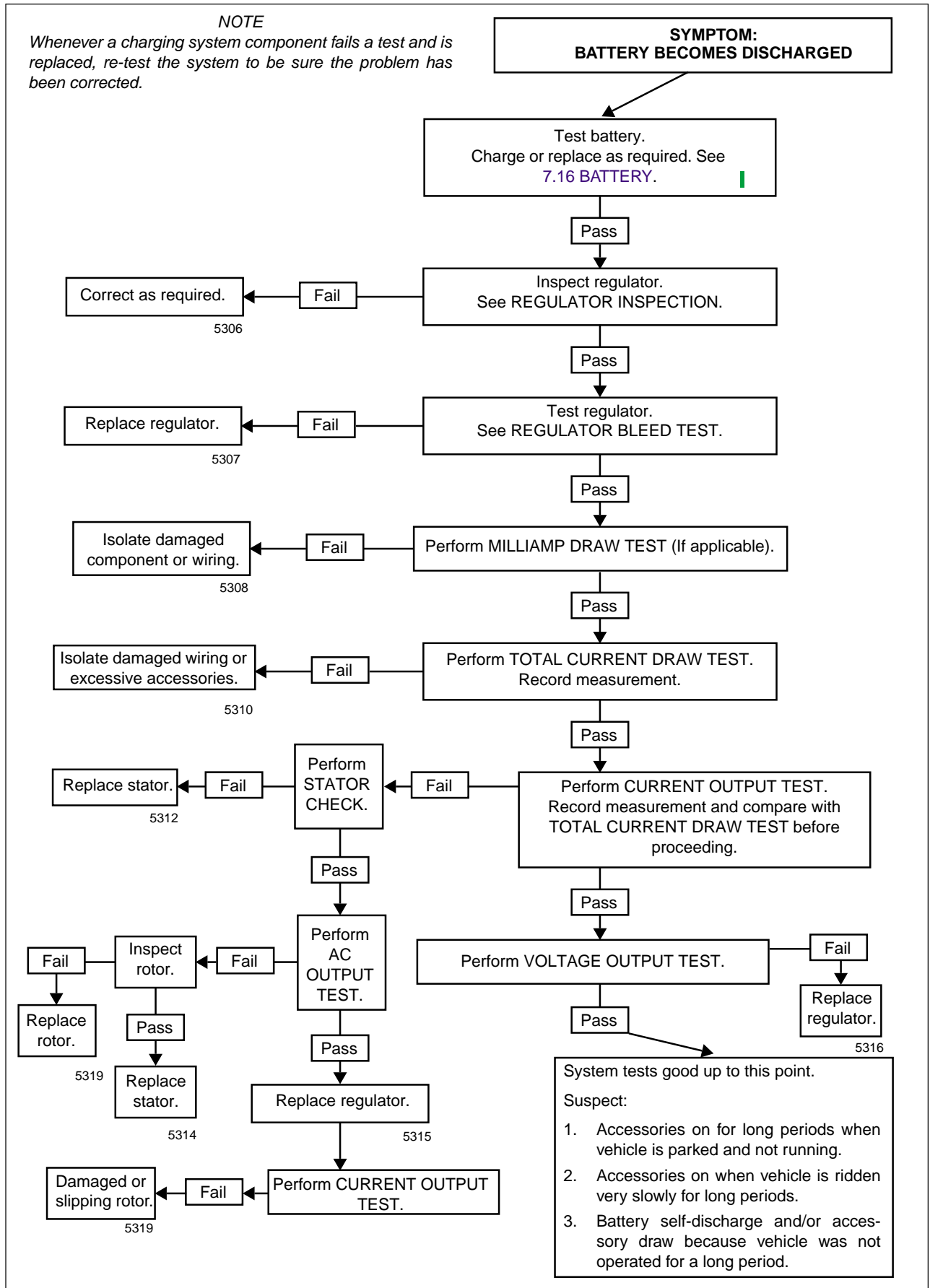

Figure 7-44. Charging System Troubleshooting

a0278x7x

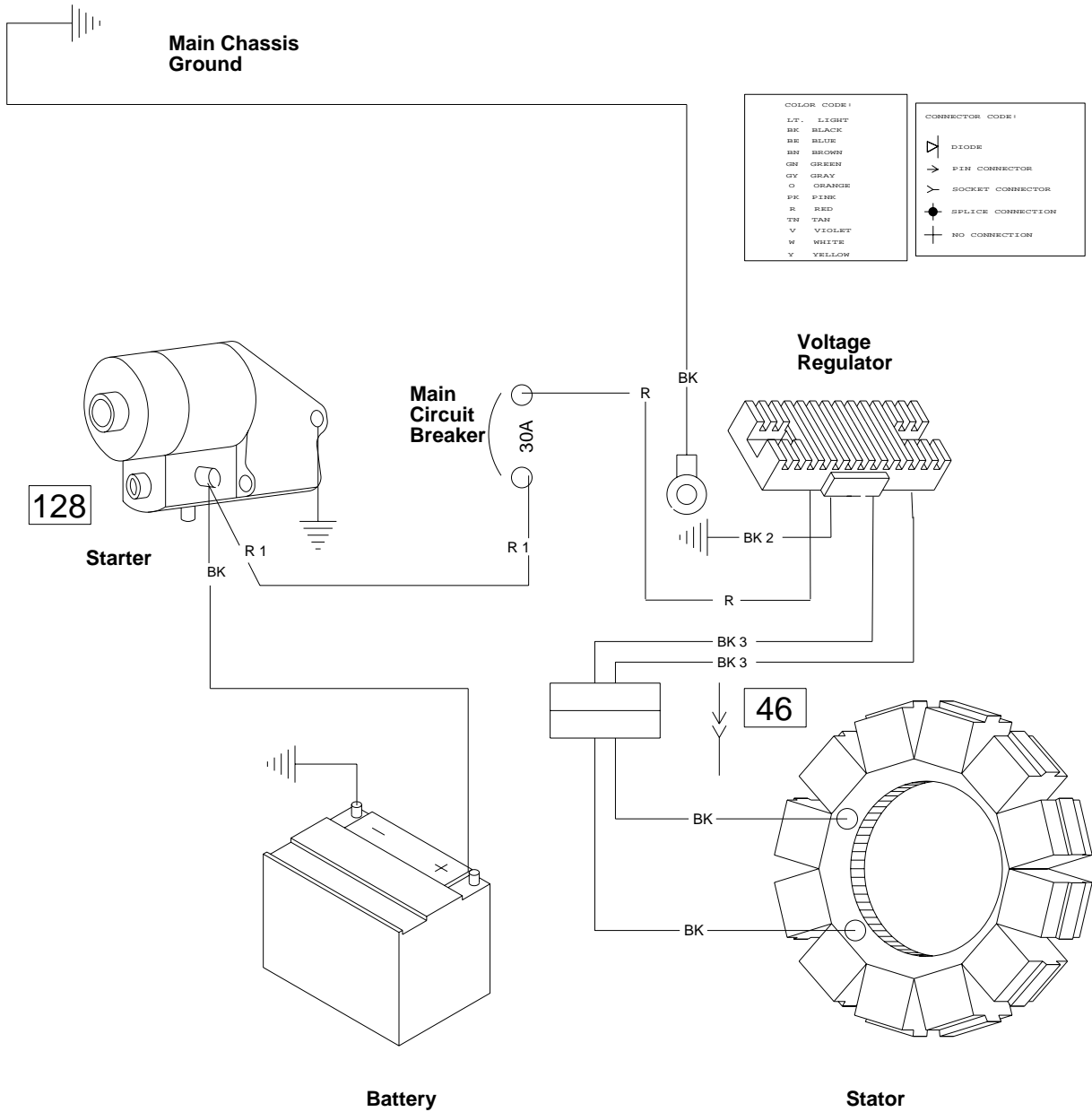

Figure 7-45. Charging System Circuit

TESTING

Voltage Regulator Bleed Test

1. Be sure regulator is connected to battery. Check BK charging wire on gold terminal of master circuit breaker.
2. Locate voltage regulator connector [46] behind left footrest support. Disconnect from alternator stator wiring. Cut cable tie and note its location.
3. Check regulator connector using a trouble light.
 - a. Touch one probe to a suitable ground.
 - b. Touch the other to the regulator pins, one at a time.
 - c. If light glows, replace regulator.

Milliampere Draw Test

NOTE

Be sure accessories are not wired so they stay on at all times. This condition could drain battery completely if vehicle is parked for a long time. Check for this by connecting ammeter between negative battery terminal and battery.

1. See Figure 7-42. Connect ammeter between negative battery terminal and battery. With this arrangement, you will also pick up any regulator drain.
2. With ignition key switch turned to LOCK and all lights and accessories off, observe amperage reading.
 - a. Maximum reading should be 1 milliampere.
 - b. A higher reading indicates excessive current draw. Any accessories must be considered and checked for excessive drain.

NOTE

A battery with a surface discharge condition could suffer a static drain. Correct by cleaning battery case.

Total Current Draw Test

If battery runs down during use, the current draw of the motorcycle components and accessories may exceed output of the charging system.

1. See Figure 7-43. To check for this condition, place load tester induction pickup or current probe pickup over battery negative cable.
2. Disconnect stator wiring from voltage regulator wiring at the connector [46]. Start the motorcycle and run the engine at 2000 RPM.
3. With ignition and all continuously running lights and accessories turned on (headlamp on high beam), read the total current draw.
4. Compare this reading to the reading obtained after performing the *CURRENT AND VOLTAGE OUTPUT TEST*.
 - a. The current output should exceed current draw by 3.5 amps minimum.
 - b. If output does not meet specifications, there may be too many accessories for the charging system to handle.
5. Reconnect regulator after testing. Replace cut cable tie.

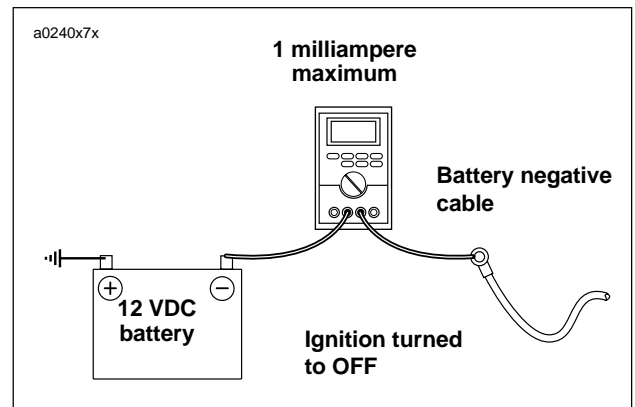

Figure 7-46. Milliampere Draw Test

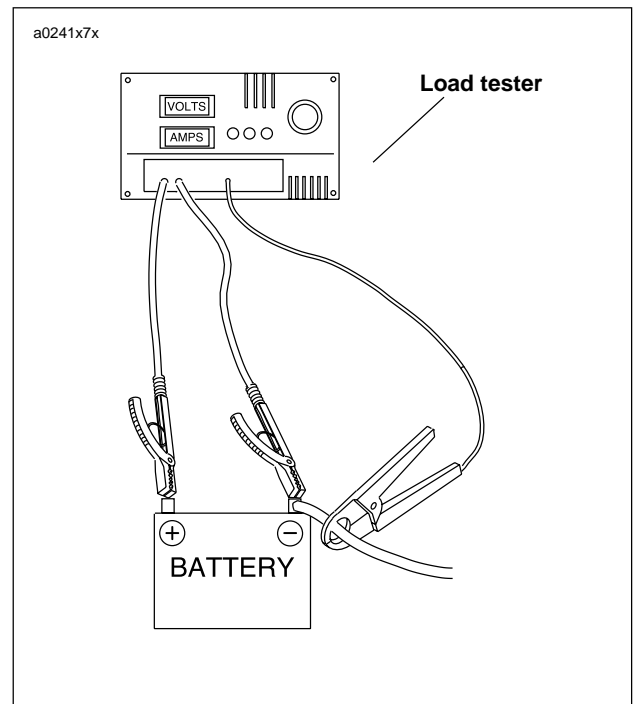

Figure 7-47. Check Current Draw (Ignition Switch ON)

Current and Voltage Output Test

1. See Figure 7-44. Connect load tester.
 - a. Connect negative and positive leads to battery terminals.
 - b. Place load tester induction pickup over positive regulator cable.

CAUTION

Do not leave any load switch turned on for more than 20 seconds or overheating and tester damage are possible.

2. Run the engine at 2000 RPM. Increase the load as required to obtain a constant 13.0 VDC.
3. The current output should be 19-23 amps. Make note of measurement for use in **TOTAL CURRENT DRAW TEST**.

NOTE

Rider's habits may require output test at lower RPM.

Voltage Output Test

1. See Figure 7-44. After removing the load, read the load tester voltage meter.
 - a. If voltage to the battery is not more than 15 VDC, voltage output is within specifications. Investigate other possible problems. See Figure 7-44.
 - b. If voltage is higher, regulator is not functioning properly or connections are loose or dirty.

Stator Check

1. Turn ignition key switch to LOCK.
2. See Figure 7-45. Connect an ohmmeter.
 - a. Locate voltage regulator connector [46] behind left footrest support. Disconnect from alternator stator wiring.
 - b. Insert one ohmmeter lead into either stator socket.
 - c. Attach the other lead to a suitable ground.
3. Test for continuity with ohmmeter set on the RX1 scale.
 - a. A good stator will show no continuity (∞ ohms) across either stator socket.
 - b. Any other reading indicates a grounded stator which must be replaced.
4. See Figure 7-46. Remove ground lead. Insert lead into the remaining stator socket.
5. Test for resistance with ohmmeter set on the RX1 scale.
 - a. Resistance across the stator sockets should be 0.2-0.4 ohms.
 - b. If the resistance is lower, the stator is damaged and must be replaced.

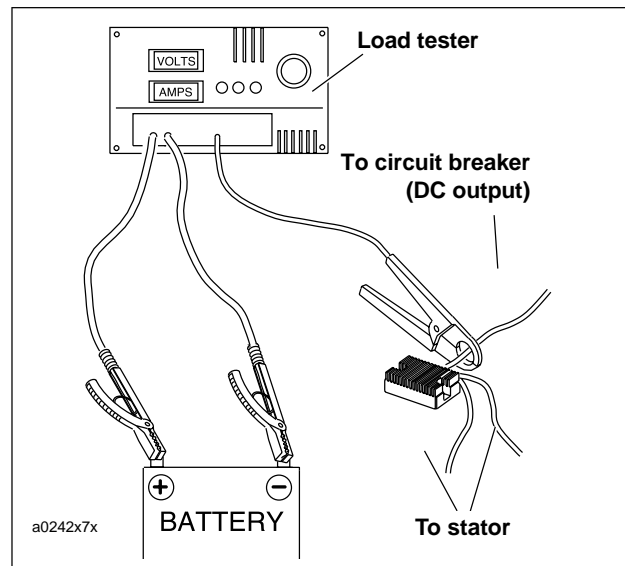

Figure 7-48. Current and Voltage Output Test

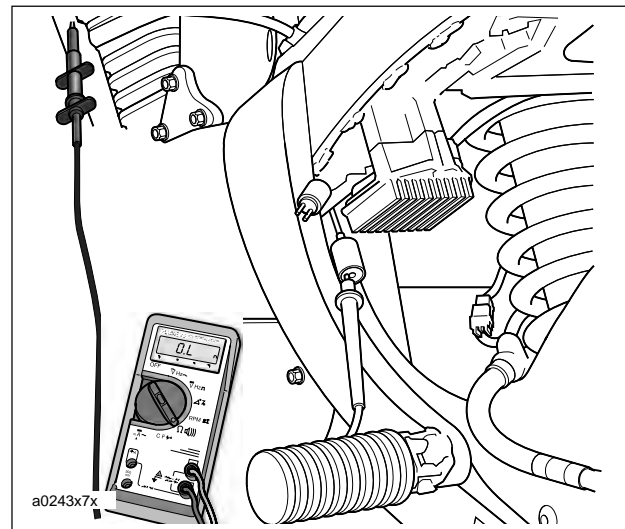

Figure 7-49. Test for Grounded Stator

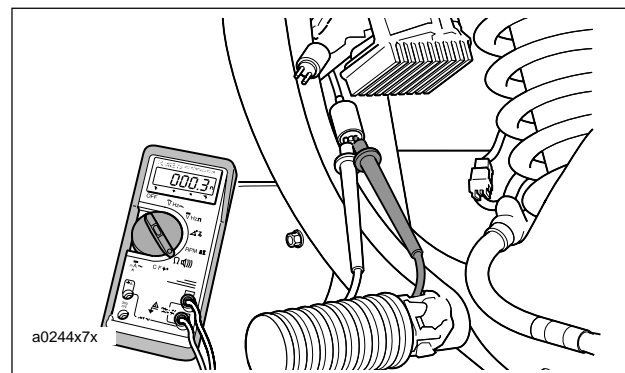

Figure 7-50. Check for Stator Resistance

AC Output Check

1. See [Figure 7-51](#). Test AC output.
 - a. Locate voltage regulator connector [46] behind left footrest support. Disconnect from alternator stator wiring.
 - b. Connect an AC voltmeter across both stator sockets.
 - c. Run the engine at 2000 RPM. The AC output should be 38-52 volts AC.
2. Compare test results to specifications.
 - a. If the output is below specifications, charging problem could be a faulty rotor or stator.
 - b. If output is good, charging problem might be faulty regulator/rectifier. Replace as required.
3. Check the output again as described under [CURRENT AND VOLTAGE OUTPUT TEST](#).

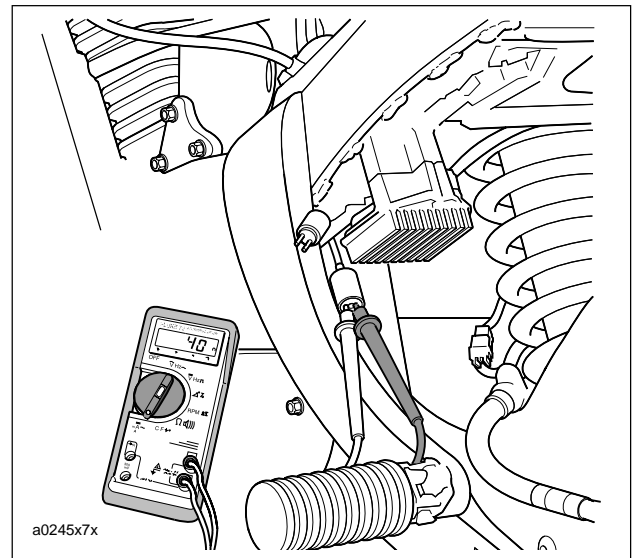

Figure 7-51. Check Stator AC Voltage Output

REMOVAL/DISASSEMBLY

WARNING

To protect against shock and accidental start-up of vehicle, disconnect the negative battery cable before proceeding. Inadequate safety precautions could result in death or serious injury.

1. Disconnect negative battery cable from battery.
2. Remove primary cover. See 6.2 PRIMARY CHAIN.
3. Remove clutch assembly, primary chain and engine sprocket/rotor assembly as a unit. See 6.6 PRIMARY DRIVE/CLUTCH.
4. Remove/disassemble rotor and/or stator, as required. Refer to the following procedures.

Rotor

1. See Figure 7-52. Remove the eight bolts which secure alternator rotor to engine sprocket.
2. See Figure 7-53. Position blocking under rotor. Press sprocket free of rotor.

NOTE

Resistance to sprocket/rotor disassembly is due in part to the magnetic force of the permanent rotor magnets.

Stator

1. See Figure 7-54. Disconnect stator wiring from voltage regulator wiring at connector [46] located behind left foot-rest support.
2. Remove cable straps holding stator wire to oil filter hose.
3. Withdraw stator wiring from behind the gearcase cover.
4. Remove and discard the four TORX screws which secure stator to left crankcase half.

CAUTION

Stator TORX screws contain a thread locking compound. Do not reuse existing screws. Always use new screws with the proper thread locking compound. Loss of torque on TORX fasteners could result in alternator damage.

5. Remove stator wiring grommet from left crankcase half.
6. Withdraw stator wiring from grommet hole in left crankcase half. Remove stator.



Figure 7-52. Rotor Assembly

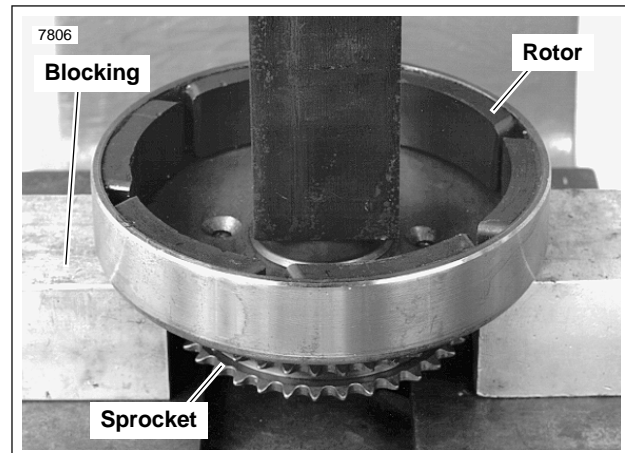

Figure 7-53. Removing Rotor From Sprocket

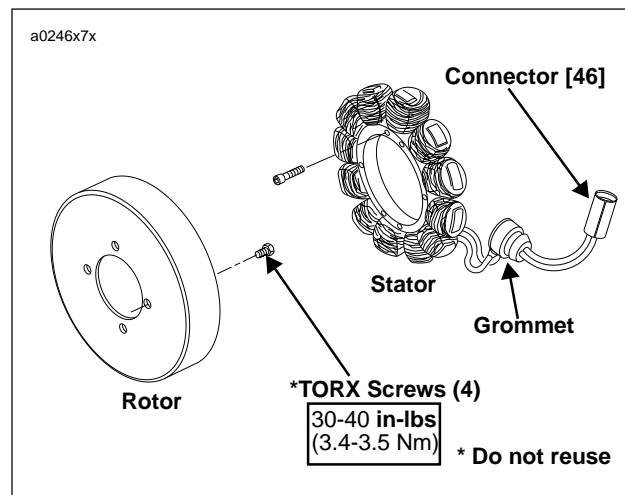

Figure 7-54. Stator Assembly

CLEANING AND INSPECTION

CAUTION

Do not strike or drop alternator rotor or damage to magnet adhesive could occur. Magnet adhesive damage can result in rotor failure.

1. Clean rotor with a petroleum-base solvent. Remove all foreign material from rotor magnets. Replace rotor if rotor magnets are cracked or loose.
2. Clean stator by wiping with a clean cloth.
3. Examine stator leads for cracked or damaged insulation.

NOTE

The rotor and stator can be replaced individually if either is damaged.

ASSEMBLY/INSTALLATION

Depending on whether the rotor, the stator, or both the rotor and stator were removed/disassembled, perform the applicable procedures which follow:

1. See [Figure 7-54](#). Feed stator wiring with attached grommet into open grommet hole in left crankcase half.
2. Apply a light coating of clean engine oil or chaincase lubricant to grommet. Install grommet into hole in left crankcase half.

CAUTION

Stator TORX screws contain a thread locking compound. Do not reuse existing screws. Always use new screws with the proper thread locking compound. Loss of torque on TORX fasteners could result in alternator damage.

3. Position stator on left crankcase half. Secure stator using four **new** TORX screws. Tighten screws to 30-40 **in-lbs** (3.4-3.5 Nm).
4. Route stator wiring under starter, behind footpeg support bracket and under seat. Cable tie connector [46] halves together.

NOTE

Temporarily attach a thin flexible "feed" or mechanic's wire to the connector end of the stator wiring to assist in the routing of the wiring.

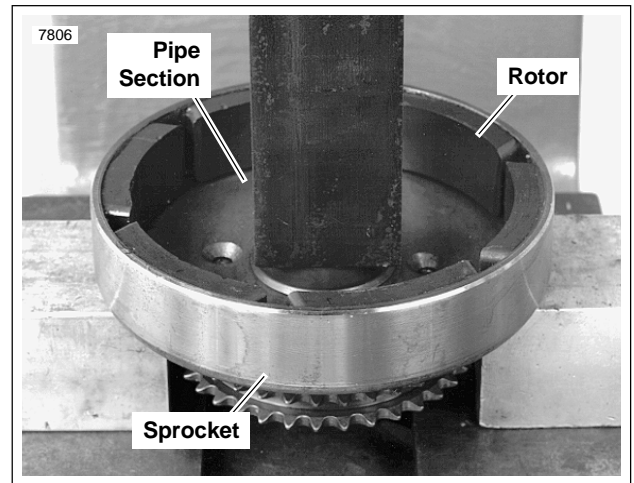

Figure 7-55. Pressing Rotor onto Sprocket

5. Connect alternator stator wiring to voltage regulator connector [46] located behind left footrest support.
6. See [Figure 7-55](#). Attach rotor to sprocket.
 - a. Position rotor on sprocket. Align holes in sprocket with holes in rotor.
 - b. Apply a drop of LOCTITE THREADLOCKER 243 (blue) to threads of each mounting bolt. Insert the eight mounting bolts through rotor and start bolts into tapped holes in sprocket.
 - c. Position a section of pipe with an inside diameter larger than the sprocket mounting hub over center of rotor. Press rotor onto sprocket. Tighten bolts to 90-110 **in-lbs** (10.2-12.4 Nm).
7. Install clutch assembly, primary chain and engine sprocket/rotor assembly as a unit. See [6.6 PRIMARY DRIVE/CLUTCH](#).
8. Install primary cover. See [6.2 PRIMARY CHAIN](#).
9. Connect negative battery cable to battery terminal. Tighten fastener to 60-96 **in-lbs** (6.8-10.9 Nm).
10. Test charging system. See [7.13 CHARGING SYSTEM](#).

GENERAL

The voltage regulator is located under the frame (above swingarm on left side). The voltage regulator is not repairable. Replace the unit if it fails.

REMOVAL

WARNING

To protect against shock and accidental start-up of vehicle, disconnect the negative battery cable before proceeding. Inadequate safety precautions could result in death or serious injury.

1. Disconnect negative battery cable from battery terminal.

CAUTION

When disconnecting the alternator stator wiring, pull apart the connector by firmly grasping both connector halves. Do not pull on leads or damage to the wires and/or terminals could result.

2. See Figure 7-56. Locate voltage regulator connector [46] behind left footrest support. Disconnect from alternator stator wiring. Cut cable straps if necessary.
3. Detach charging wire from main circuit breaker.
 - a. Remove seat. See Section 2.
 - b. See Figure 7-57. Disconnect Red charging wire from gold post of main circuit breaker.
 - c. Route charging wire back to voltage regulator.
4. Remove two mounting screws.
5. Remove and discard voltage regulator.

INSTALLATION

1. Apply LOCTITE THREADLOCKER 243 (Blue) to threads of two mounting screws.
2. See Figure 7-57. Attach **new** voltage regulator using two screws. Tighten screws to 4-6 ft-lbs (5.4-8 Nm).
3. Connect voltage regulator connector [46] to alternator stator wiring. Cable tie connector halves together.
4. Route Red charging wire to gold post on main circuit breaker. Secure wire to frame with **new** cable straps.

WARNING

After installing seat, pull upward on front of seat to be sure it is locked in position. If seat is loose, it could shift during vehicle operation and startle the rider, causing loss of control of vehicle and death or serious injury.

5. Install seat. See 2.29 SEAT.
6. Connect negative battery cable to battery terminal. Tighten fastener to 60-96 in-lbs (6.8-10.9 Nm).
7. Test charging system. See 7.13 CHARGING SYSTEM.

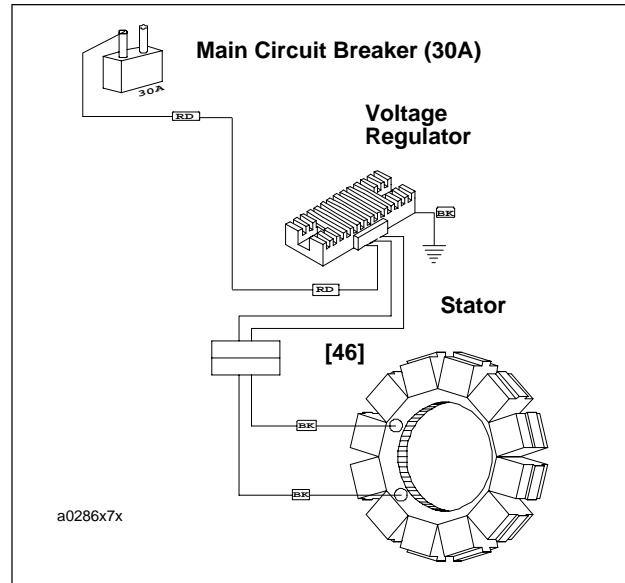

Figure 7-56. Voltage Regulator Connector [46]

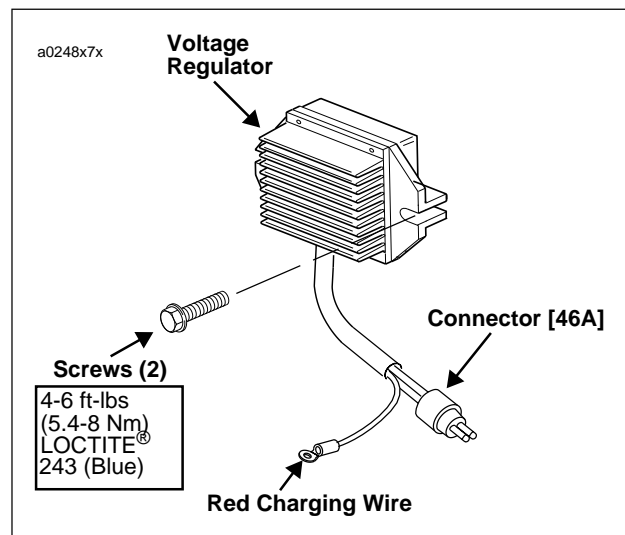

Figure 7-57. Voltage Regulator

GENERAL

All 2001 Model Year Buell batteries are permanently sealed, maintenance-free, valve-regulated, lead/calcium and sulfuric acid batteries. The batteries are shipped pre-charged and ready to be put into service. Do not attempt to open these batteries for any reason.

WARNING

All batteries contain electrolyte. Electrolyte is a sulfuric acid solution that is highly corrosive and can cause severe chemical burns. Avoid contact with skin, eyes, and clothing. Avoid spillage. Always wear protective face shield, rubberized gloves and protective clothing when working with batteries. A warning label is attached to the top of the battery. See Figure 7-58. and Figure 7-59. Never remove warning label from battery. Failure to read and understand all precautions contained in warning label before performing any service on batteries could result in death or serious injury.

BATTERY TESTING

Voltmeter Test

See Table 7-1. The voltmeter test provides a general indicator of battery condition. Check the voltage of the battery to verify that it is in a 100% fully charged condition. If the open circuit (disconnected) voltage reading is below 12.6V, charge the battery and then recheck the voltage after the battery has set for one to two hours. If the voltage reading is 12.8V or above, perform the load test.

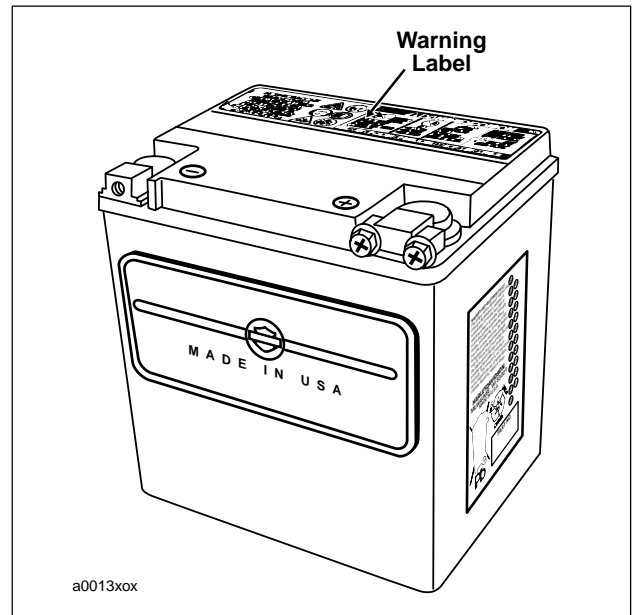

Figure 7-58. Maintenance-Free AGM Battery

ANTIDOTE	
External	– Flush with water.
Internal	– Drink large quantities of milk or water, followed by milk of magnesia, vegetable oil or beaten eggs. Call doctor immediately.
Eyes	– Flush with water, get immediate medical attention.

Figure 7-59. Antidote

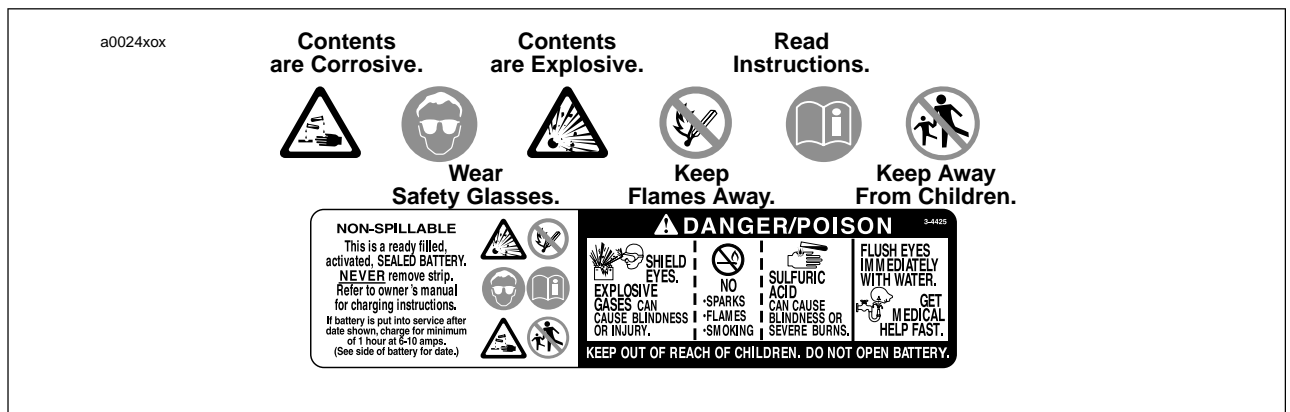

Figure 7-60. Battery Warning Label

Table 7-1. Voltmeter Test

BATTERY CHARGE CONDITIONS	
Voltage (OCV)	State of Charge
12.8	100%
12.6	75%
12.3	50%
12.0	25%
11.8	0%

DISCONNECTION AND REMOVAL

1. Remove seat. See 2.29 SEAT.

WARNING

To protect against shock and accidental start-up of vehicle, disconnect the negative battery cable before proceeding. Inadequate safety precautions could result in death or serious injury.

WARNING

Always disconnect the negative cable first. If the positive cable should contact ground with the negative cable installed, the resulting sparks may cause a battery explosion which could result in death or serious injury.

2. Unthread bolt and remove battery negative cable (black) from battery negative (-) terminal.
3. Unthread bolt and remove battery positive cable (red) from battery positive (+) terminal.
4. Remove battery from motorcycle.

CLEANING AND INSPECTION

1. Battery top must be clean and dry. Dirt and electrolyte on top of the battery can cause battery to self-discharge. Clean battery top with a solution of baking soda (sodium bicarbonate) and water (5 teaspoons baking soda per quart or liter of water). When the solution stops bubbling, rinse off the battery with clean water.
2. Clean cable connectors and battery terminals using a wire brush or sandpaper. Remove any oxidation.
3. Inspect the battery screws, clamps and cables for breakage, loose connections and corrosion. Clean clamps.
4. Check the battery posts for melting or damage caused by overtightening.
5. Inspect the battery for discoloration, raised top or a warped or distorted case, which might indicate that the battery has been frozen, overheated or overcharged.
6. Inspect the battery case for cracks or leaks.

BATTERY CHARGING

Safety Precautions

Never charge a battery without first reviewing the instructions for the charger being used. In addition to the manufacturer's

instructions, follow these general safety precautions:

- Always wear proper eye, face and hand protection.
- Always charge batteries in a well-ventilated area.
- Turn the charger "OFF" before connecting the leads to the battery to avoid dangerous sparks.
- Never try to charge a visibly damaged or frozen battery.
- Connect the charger leads to the battery; red positive (+) lead to the positive (+) terminal and black negative (-) lead to the negative (-) terminal. If the battery is still in the vehicle, connect the negative lead to the chassis ground. Be sure that the ignition and all electrical accessories are turned off.
- Make sure that the charger leads to the battery are not broken, frayed or loose.
- If the battery becomes hot, or if violent gassing or spewing of electrolyte occurs, reduce the charging rate or turn off the charger temporarily.
- Always turn the charger "OFF" before removing charger leads from the battery to avoid dangerous sparks.

Charging Battery

Charge the battery if any of the following conditions exist:

- Vehicle lights appear dim.
- Electric starter sounds weak.
- Battery has not been used for an extended period of time.

WARNING

Charge the battery in a well ventilated area. Explosive hydrogen gas escapes from the battery during charging. Keep open flames, electrical sparks and smoking materials away from the battery at all times. Inadequate safety precautions could result in death or serious injury.

CAUTION

If the battery releases an excessive amount of gas during charging, decrease the charging rate. If the battery gets hotter than 110°F. (43°C) during charging, discontinue charging and allow the battery to cool. Overheating may result in plate distortion, internal shorting, dry out or other damage.

1. Perform a voltmeter test to determine the state of charge. See BATTERY TESTING, VOLTMETER TEST.

WARNING

Always connect the positive battery cable first. If the positive cable should contact ground with the negative cable installed, the resulting sparks may cause a battery explosion which could result in death or serious injury.

CAUTION

Always remove the battery from the motorcycle before charging. Accidental electrolyte leakage will damage motorcycle parts.

2. Install the battery on the motorcycle. See BATTERY, INSTALLATION AND CONNECTION.

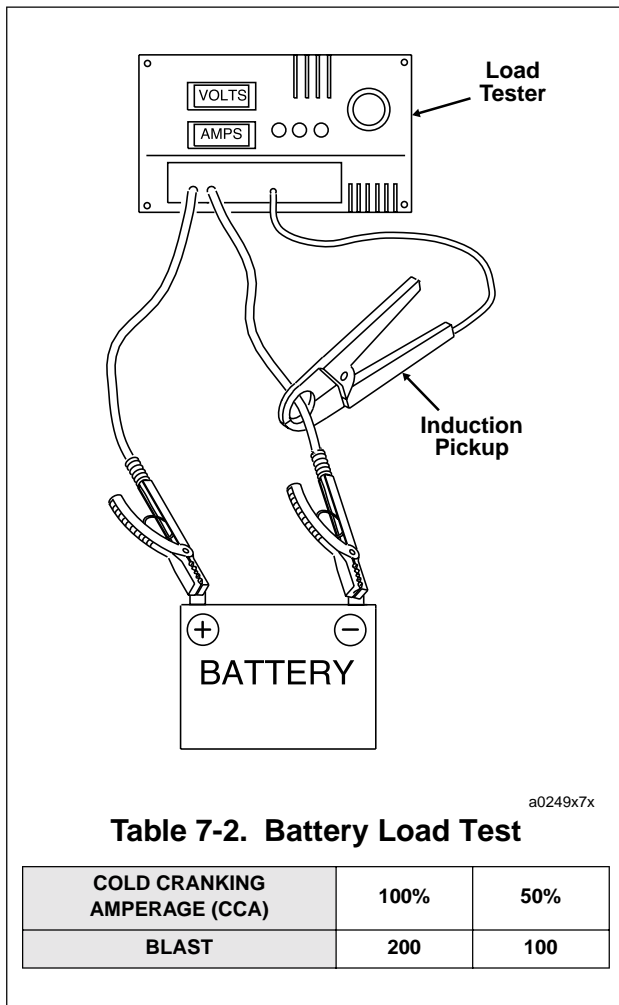

Table 7-2. Battery Load Test

COLD CRANKING AMPERAGE (CCA)	100%	50%
BLAST	200	100

Figure 7-61. Load Test Battery

BATTERY CABLE ROUTING

Positive battery cable runs from the starter post to the positive battery terminal. Negative battery cable runs from frame to negative battery terminal. NOTE: route negative battery cable between battery and frame rail.

BATTERY INSTALLATION AND CONNECTION

1. Place the fully charged battery on the battery pad, terminal side facing up.

CAUTION

Connect the cables to the correct battery terminals or damage to the motorcycle electrical system will occur.

WARNING

Always connect the positive battery cable first. If the positive cable should contact ground with the negative cable installed, the resulting sparks may cause a battery explosion which could result in death or serious injury.

CAUTION

Overtightening bolts can damage battery terminals.

2. See Figure 7-62. Insert bolt through battery positive cable (red) into threaded hole of battery positive (+) terminal. Tighten bolt to 60-96 **in-lbs** (6.8-10.9 Nm).
3. See Figure 7-62. Insert bolt through battery negative cable (black) into threaded hole of battery negative (-) terminal. Tighten bolt to 60-96 **in-lbs** (6.8-10.9 Nm).
4. Apply a light coat of petroleum jelly or corrosion retardant material to both battery terminals.
5. Install seat. See [2.29 SEAT](#).

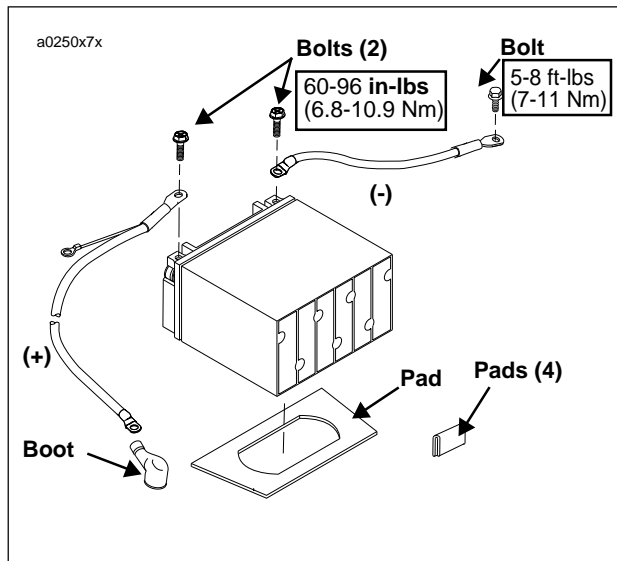

Figure 7-62. Battery Installation

STORAGE

WARNING

Always store batteries where they cannot be reached by children. Contact with the battery's sulfuric acid could result in death or serious injury.

CAUTION

The electrolyte in a discharged battery will freeze if exposed to freezing temperatures. Freezing may crack the battery case and buckle battery plates.

If the motorcycle will not be operated for several months, such as during the winter season, remove the battery from the motorcycle and fully charge. See CHARGING BATTERY.

Self-discharge is a normal condition and occurs continuously at a rate that depends on the ambient temperature and the battery's state of charge. Batteries discharge at a faster rate at higher ambient temperatures. To reduce the self-discharge rate, store battery in a cool (not freezing), dry place. See Figure 7-63.

Charge the battery every month if stored at temperatures below 60° F. (16° C). Charge the battery more frequently if stored in a warm area above 60° F. (16° C).

NOTE

The H-D Battery Tender Automatic Battery Charger (P/N 99863-93TA) may be used to maintain battery charge for extended periods of time without risk of overcharging or boiling.

When returning a battery to service after storage, refer to the instructions under CHARGING BATTERY.

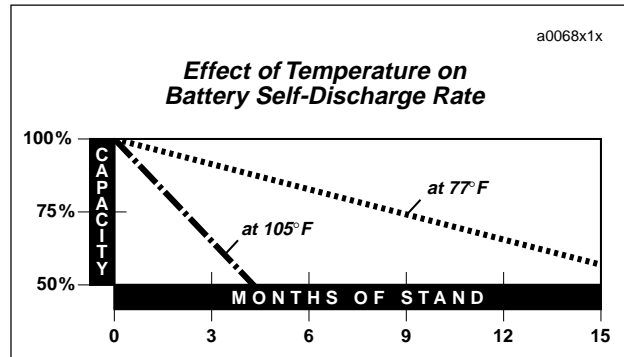

Figure 7-63. Battery Self-Discharge Rate

REMOVAL/DISASSEMBLY

Headlamp

NOTE

The headlamp is a sealed assembly and not repairable. If bulb fails, replace headlamp assembly.

1. Remove four screws, washers and windscreen. See 2.27 WINDSCREEN.
2. See Figure 7-64. Remove three phillips head screws and bezel from nest.
3. Remove three screws and retaining ring.
4. Slide headlamp from headlamp housing and detach headlamp connector from rear of headlamp.

CAUTION

The headlamp contains Halogen gas under pressure. Handle headlamp carefully and wear eye protection. If the headlamp is mishandled or dropped, it could explode which could result in mild or moderate injury.

Headlamp Housing and Brackets

1. See Figure 7-64. Using 3/16 allen bit, remove two screws and washers and partially remove headlamp housing from vehicle.
2. Detach connector [38] from wiring harness. Remove headlamp housing from vehicle.
3. To remove nest, remove two adjusting screws and detach spring from nest.
4. Remove headlamp brackets.
 - a. Remove front turn signals. See 7.19 TURN SIGNALS.
 - b. Remove two screws from bracket.
 - c. Repeat for other bracket.
 - d. Remove front forks and headlamp brackets. See 2.18 FRONT FORK.
 - e. Remove windscreen from brackets. See 2.27 WINDSCREEN.

ASSEMBLY/INSTALLATION

Headlamp Housing and Brackets

1. Install headlamp brackets.
 - a. Install front forks through triple clamps and brackets. See 2.18 FRONT FORK.
 - b. See Figure 7-64. Install bracket with two allen screws.
 - c. Repeat for other bracket
 - d. Attach both front turn signals. See 7.19 TURN SIGNALS.
 - e. Install windscreen if removed with four screws and washers. See 2.27 WINDSCREEN.

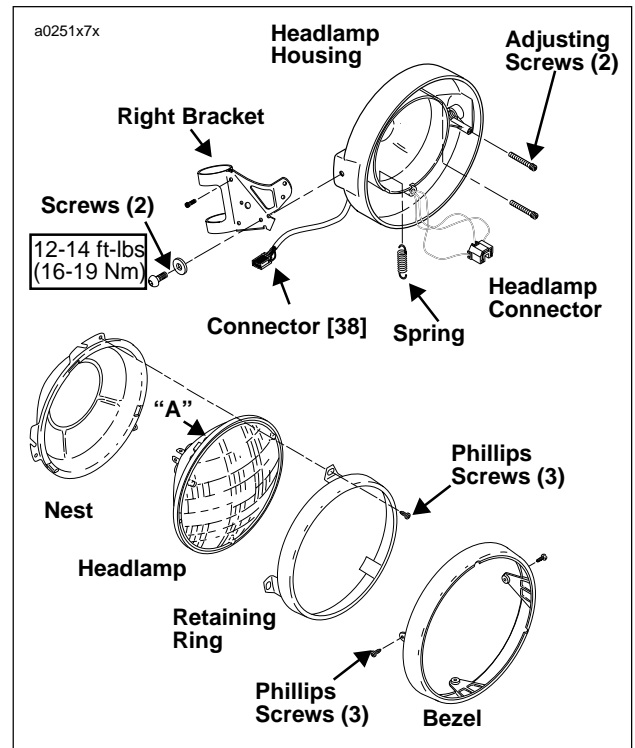

Figure 7-64. Headlamp Assembly

2. See Figure 7-64. Attach connector [38] to wiring harness.
3. See Figure 7-64. Install headlamp housing using two screws and washers. Tighten to 12-14 ft-lbs (16-19 Nm).

Headlamp

CAUTION

The headlamp contains Halogen gas under pressure. Handle headlamp careful and wear eye protection. If the headlamp is mishandled or dropped, it could explode which could result in mild or moderate injury.

1. See Figure 7-64. Connect headlamp connector to rear of headlamp.

NOTE

Align protrusion "A" on headlamp with slot in upper portion of nest for proper fit. Retaining ring only fits one way. Rotate retaining ring until all three holes align.

2. Install headlamp and retaining ring to nest with three phillips screws. Tighten screws to 12-14 in-lbs (1.4-1.6 Nm).

NOTE

Make sure slots on bezel are positioned so they allow access to adjusting screws.

3. Install bezel to retaining ring with three phillips screws. Tighten screws to 12-14 in-lbs (1.4-1.6 Nm).
4. Install windscreen with four screws and washers. See 2.27 WINDSCREEN.

WARNING

Check for proper headlamp operation before riding motorcycle. Visibility is a major concern for motorcyclists. Failure to have proper headlamp operation could result in death or serious injury.

5. Check headlamp for proper operation.
 - a. Turn ignition key switch to IGN.
 - b. See [Figure 7-66](#). Check headlamp LOW and HIGH beam settings.
 - c. Set headlamp to LOW beam. Press passing lamp switch. Headlamp should flash HIGH beam for as long as the switch is pressed.
 - d. Turn ignition key switch to LOCK.
 - e. If operation fails, reread procedure and verify that all steps were performed.
6. Align headlamp. See [ALIGNMENT](#).

ALIGNMENT**WARNING**

Do not modify ignition/light switch wiring to circumvent the automatic-on headlamp feature. Operating with headlamp off will reduce your visibility to other motorists and could cause an accident resulting in death or serious injury.

Check headlamp beam for proper height and lateral alignment as follows:

1. Verify correct front and rear tire inflation pressure. See Section 2.
2. Place motorcycle on level floor (or pavement) in an area with minimum light.
3. See [Figure 7-65](#). Point front of motorcycle toward a screen or wall which is 25 ft (7.62 M) away from front tire contact patch on floor (directly below front axle).
4. Draw a horizontal line on the screen or wall 35 in. (88.9 cm) above the floor.
5. Have a person whose weight is roughly the same as that of the principal rider sit on motorcycle seat. Weight of rider will compress vehicle suspension slightly.
6. Stand motorcycle upright with both tires resting on floor and with front wheel held in straight alignment (directly forward).
7. See [Figure 7-66](#). Turn ignition switch to IGN. Set handlebar headlamp switch to HIGH beam position.
8. Check light beam for proper height alignment. Main beam of light (broad, flat pattern of light) should be centered on horizontal line on screen or wall (i.e. equal area of light above and below line).
9. Check light beam for proper lateral alignment. Main beam of light should be directed straight ahead (i.e. equal area of light to right and left of center).
10. Adjust headlamp if necessary. See [ADJUSTMENT](#).

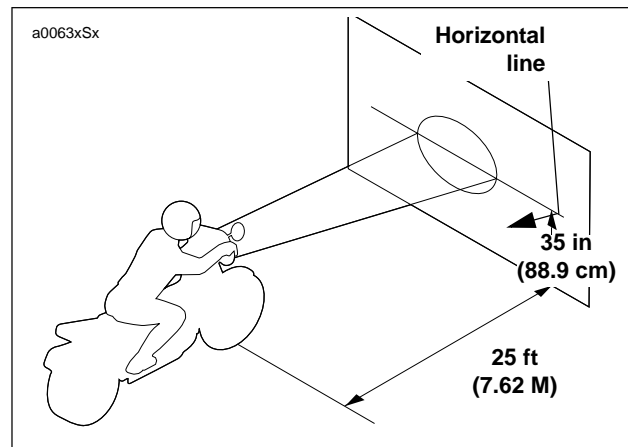

Figure 7-65. Checking Headlamp Alignment

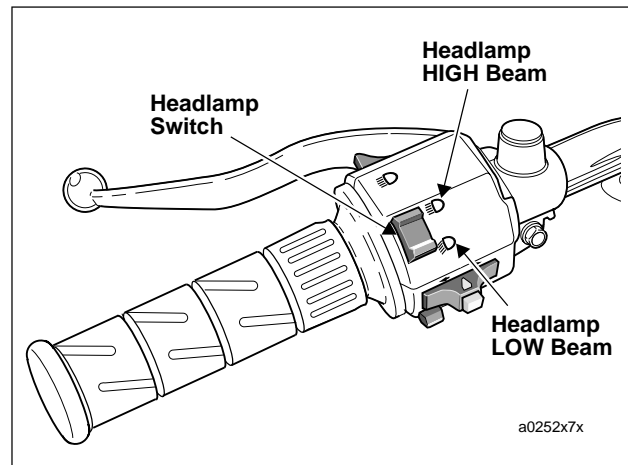

Figure 7-66. Headlamp Switch

ADJUSTMENT

Tilt headlamp up or down to aim it in relation to the horizontal line. At the same time, turn headlamp right or left to direct light beam straight ahead.

1. Adjusting head lamps.
 - a. Aim headlamp.
 - b. Tighten both adjuster screws (metric) to 6-8 ft-lbs (8.2-10.8 Nm).

NOTE:

Use a standard phillips screwdriver on the right side headlamp mounting stud to change lateral alignment. Turn the stud clockwise to shift beam to the right; turn the stud counterclockwise to shift beam to the left.

- c. See [Figure 7-67](#). Turn vertical headlamp mounting adjuster clockwise to raise beam height.
- d. See [Figure 7-67](#). Turn horizontal headlamp mounting adjuster clockwise to change lateral alignment.

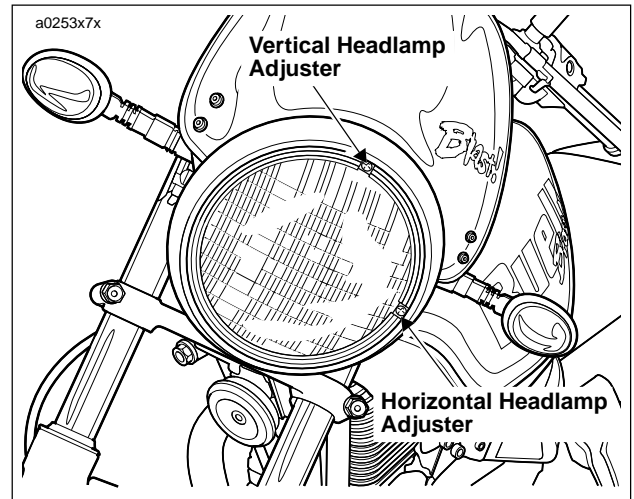

Figure 7-67. Headlamp Vertical/Horizontal Adjusters

Bulb Replacement

1. See Figure 7-68. Remove two screws and lens.
2. Rotate bulb counterclockwise and pull to remove.
3. Install **new** tail lamp bulb by pushing into socket and rotating bulb clockwise.
4. Install tail lamp lens with two screws.

REMOVAL

1. See Figure 7-68. Disconnect the 6-place tail lamp connector from rear of tail lamp under tail section.
2. Remove two locknuts (metric), washers and tail lamp.

INSTALLATION

NOTE

Push up on metal bracket under tail section to align tail lamp mounting holes.

1. See Figure 7-68. Attach tail lamp to tail section with two washers and locknuts (metric). Tighten locknuts to 23-33 **in-lbs** (2.6-3.7 Nm).
2. See Figure 7-68. Attach the 6-place tail lamp connector to the back of the tail lamp.

WARNING

Check for proper tail lamp operation before riding motorcycle. Visibility is a major concern for motorcyclists. Failure to have proper tail lamp operation could result in death or serious injury.

3. Check tail lamp for proper operation. If operation fails, reread procedure and verify that all steps were performed.
 - a. Turn ignition key switch to IGN.
 - b. Check for tail lamp illumination.
 - c. Squeeze front brake hand lever. Check for brake lamp illumination. Release front brake hand lever.
 - d. Press rear brake pedal. Check for brake lamp illumination. Release rear brake pedal.
 - e. Turn ignition key switch to LOCK.

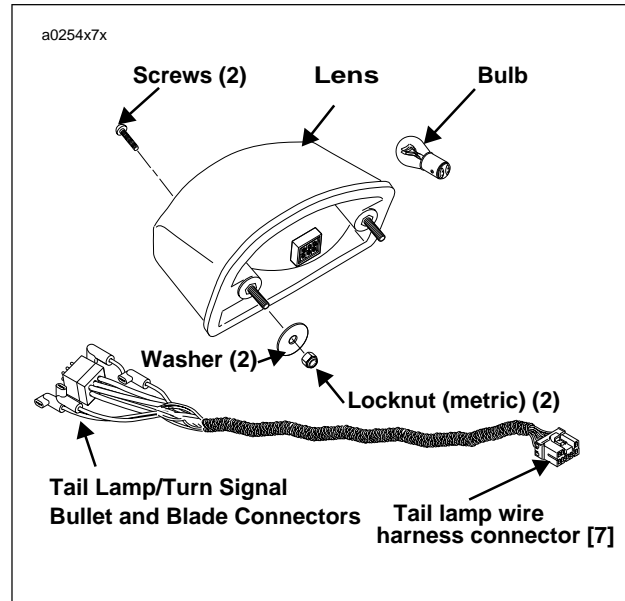

Figure 7-68. Tail Lamp

REMOVAL

NOTE

Remove screw on back of turn signal to detach lens and install **new** turn signal bulbs.

Front bulbs are identical to rear bulbs.

Front

1. Remove four screws, washers and windscreen. See 2.27 WINDSCREEN.
2. See Figure 7-69. Disconnect two bullet connectors on turn signal wires.
3. See Figure 7-70. Remove nut and lockwasher.
4. Remove turn signal from headlamp bracket.
5. Repeat steps 2-4 for other turn signal.

Rear

1. Cut cable strap that secures bullet connectors under tail section.
2. See Figure 7-72. Disconnect two bullet connectors on turn signal wires.
3. See Figure 7-71. Remove nut and lockwasher.
4. Remove turn signal from tail lamp bracket.
5. Repeat steps 2-4 for other turn signal.

INSTALLATION

Front

1. See Figure 7-70. Install turn signal with lockwasher and nut. Tighten nut to 25-28 **in-lbs** (2.8-3.2 Nm).

NOTE

Install turn signal with lens drain hole facing downward.

2. Attach two bullet connectors on turn signal wires as shown in Figure 7-69.
3. Install four screws, washers and windscreen. See 2.27 WINDSCREEN.

 **WARNING**

Check for proper turn signal operation before riding motorcycle. Visibility is a major concern for motorcyclists. Failure to have proper turn signal operation could result in death or serious injury.

4. Check turn signals for proper operation. If operation fails, reread procedure and verify that all steps were performed.
 - a. Turn ignition key switch to IGN.
 - b. Activate left turn signals using switch on left handlebar. Front and rear left turn signals must flash.
 - c. Activate right turn signals using switch on left handlebar. Front and rear right turn signals must flash.
 - d. Turn ignition key switch to LOCK.

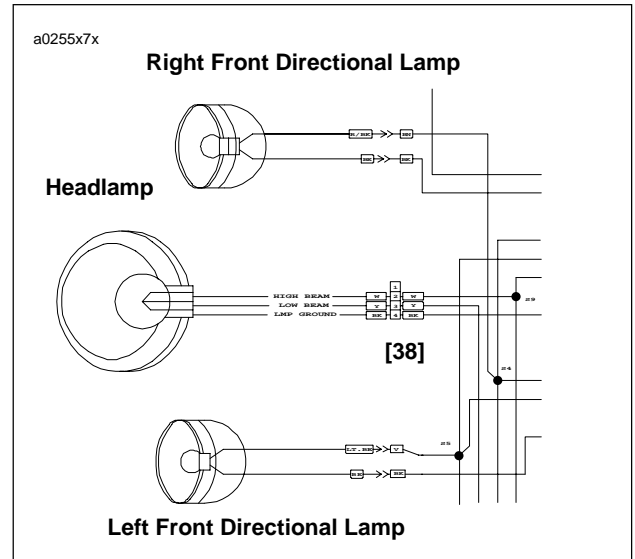

Figure 7-69. Front Turn Signal Connections

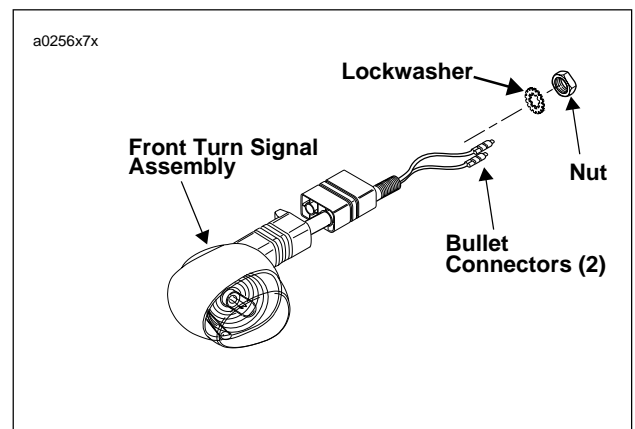

Figure 7-70. Front Turn Signals

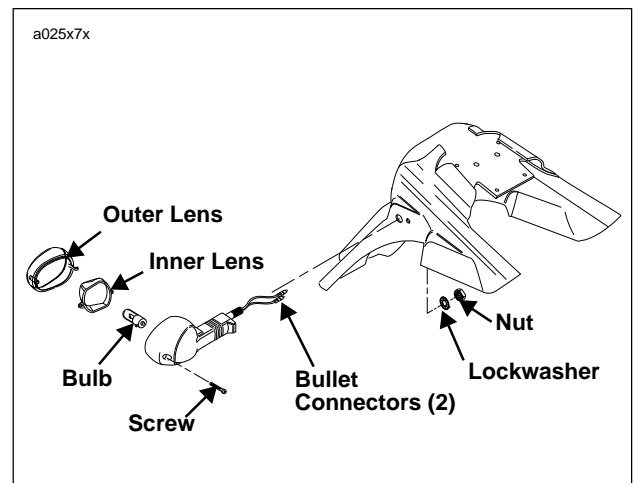

Figure 7-71. Rear Turn Signals

Rear

1. See Figure 7-71. Insert bullet connectors through rear hole in tail lamp bracket. Attach turn signal using lock-washer and nut. Tighten nut to 25-28 **in-lbs** (2.8-3.2 Nm).

NOTE

Install turn signal with lens drain hole facing downward.

2. Attach two bullet connectors on turn signal wires as shown in Figure 7-72.
3. Use **new** cable strap to bundle turn signal wires beneath tail section.

WARNING

Check for proper turn signal operation before riding motorcycle. Visibility is a major concern for motorcyclists. Failure to have proper turn signal operation could result in death or serious injury.

4. Check turn signals for proper operation. If operation fails, reread procedure and verify that all steps were performed.
 - a. Turn ignition key switch to IGN.
 - b. Activate left turn signals using switch on left handlebar. Front and rear left turn signals must flash.
 - c. Activate right turn signals using switch on left handlebar. Front and rear right turn signals must flash.
 - d. Turn ignition key switch to LOCK.

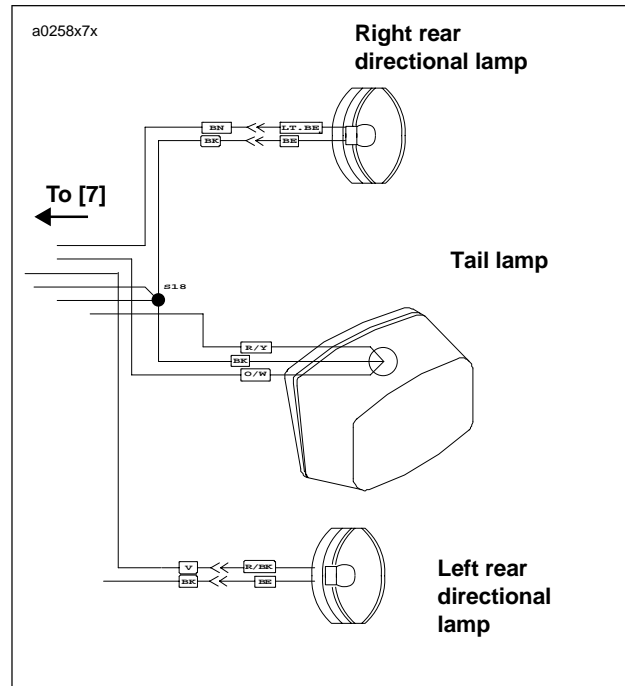

Figure 7-72. Rear Turn Signal Connections

REMOVAL

NOTE

The turn signal flasher is not repairable. Replace the unit if it fails.

1. Remove seat. See 2.29 SEAT.

WARNING

Always disconnect the negative battery cable first. If the positive cable should contact ground with the negative cable installed, the resulting sparks may cause a battery explosion that could result in death or serious injury.

2. Disconnect negative battery cable.
3. Pry tab on circuit breaker clip left side and remove circuit breaker from clip with wires still attached.
4. See Figure 7-73. Remove screw and flasher relay from frame tray.
5. Unplug relay connector [30] from flasher relay and remove flasher relay.

INSTALLATION

1. See Figure 7-73. Connect relay connector [30] to new turn signal flasher relay.
2. Attach flasher relay to frame tray with screw. Tighten screw to 4-6 ft-lbs (5.4-8 Nm).
3. Install circuit breaker to clip.
4. Connect negative battery cable to battery terminal. Tighten fastener to 60-96 in-lbs (6.8-10.9 Nm).

WARNING

Check for proper turn signal operation before riding motorcycle. Visibility is a major concern for motorcyclists. Failure to have proper turn signal operation could result in death or serious injury.

5. Check turn signals for proper operation. If operation fails, reread procedure and verify that all steps were performed.
 - a. Turn ignition key switch to IGN.
 - b. Activate left turn signals using switch on left handlebar. Front and rear left turn signals must flash.
 - c. Activate right turn signals using switch on left handlebar. Front and rear right turn signals must flash.
 - d. Turn ignition key switch to LOCK.

WARNING

After installing seat, pull upward on front of seat to be sure it is locked in position. If seat is loose, it could shift during vehicle operation and startle the rider, causing loss of control of vehicle and death or serious injury.

6. Install seat. See 2.29 SEAT.

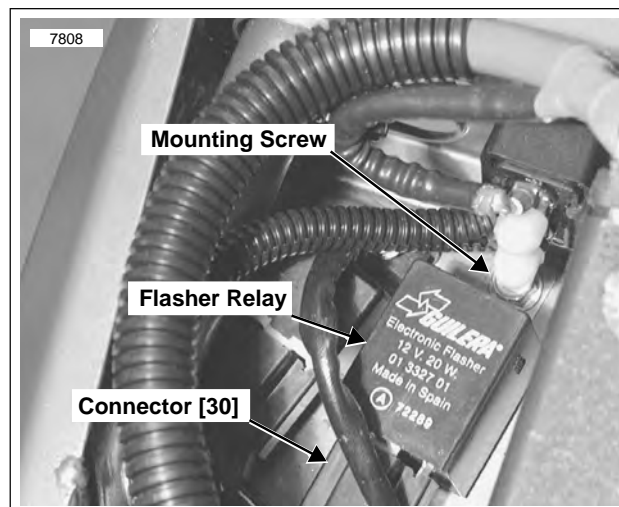

Figure 7-73. Turn Signal Flasher

REMOVAL

NOTE

The individual handlebar switches are not repairable. Replace switch assembly upon switch failure.

Right Side

1. Detach throttle cables.
2. See Figure 7-74. Cut cable strap to access right handlebar switch connector [22] behind dash. Detach connector [22] from wiring harness.
3. Cut as many cable straps as necessary to access brake switch connector [170]. Detach connector [170] from wiring harness.

Left Side

1. Remove three screws from handlebar switch.
2. Separate switch housings and remove from handlebar.
3. See Figure 7-76. Cut cable strap(s) as necessary to access left handlebar switch connector [24] and clutch switch connector [95] behind dash. Detach connector [24] from wiring harness.
4. Remove connector [95] from clutch switch.

INSTALLATION

Right Side

1. Attach throttle cables to hand control.
2. Position housings on right handlebar by engaging stud on front housing with hole in handlebar. Fasten housings with two screws. Tighten to 12-17 **in-lbs** (1.4-1.9 Nm).
3. See Figure 7-74. Route switch housing wiring harness between front forks. Attach connector [170] and connector [22] to wiring harness. Fasten wiring harness behind dash with **new** cable straps.
4. Adjust throttle cables. See 1.18 THROTTLE CABLES.

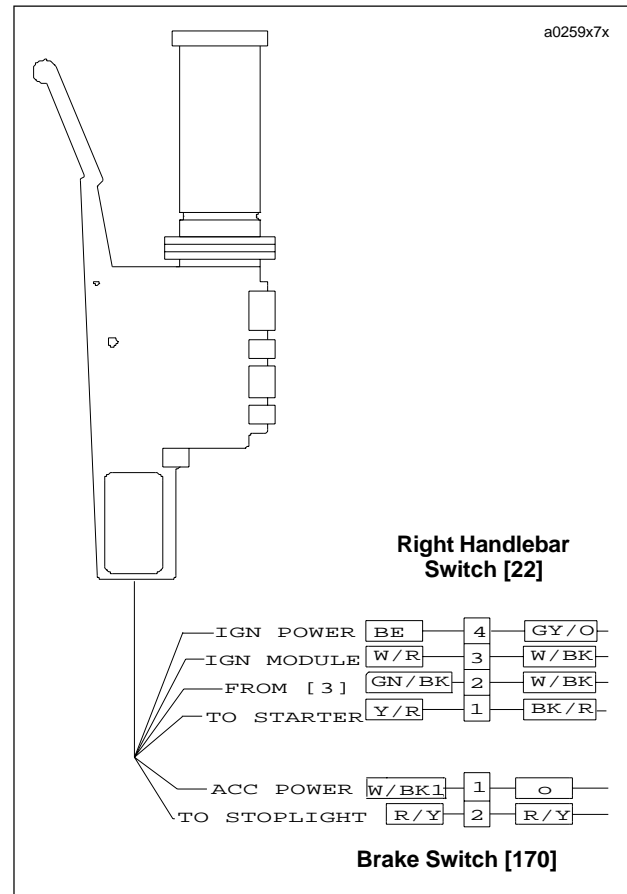

Figure 7-74. Right Handlebar Switch Connection

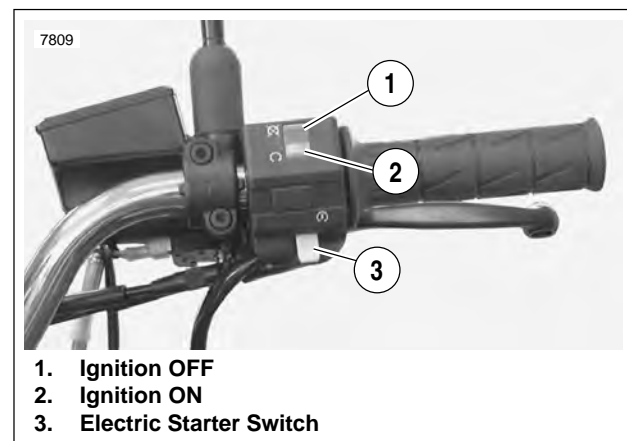

Figure 7-75. Right Handlebar Switches

WARNING

Check all handlebar switch operations before riding motorcycle. Handlebar switches not operating properly could result in death or serious injury.

5. Check handlebar switch for proper operation. If operation fails, reread procedure and verify that all steps were performed.
 - a. Turn ignition key switch to IGN.
 - b. Start motorcycle.
 - c. Turn ignition key switch to LOCK.

Left Side

1. Attach switch housing to handlebar with three screws. Tighten screws to 25-33 **in-lbs** (2.8-3.7 Nm).
2. See [Figure 7-76](#). Route switch housing wiring harness between front forks. Attach connector [24] and connector [95] to wiring harness. Fasten wiring harness behind dash with **new** cable straps.

WARNING

Check all handlebar switch operations before riding motorcycle. Handlebar switches not operating properly could result in death or serious injury.

3. Check handlebar switch for proper operation. If operation fails, reread procedure and verify that all steps were performed.
 - a. Turn ignition key switch to IGN.
 - b. Check headlamp LOW and HIGH beam settings.
 - c. Set headlamp to LOW beam. Press passing lamp switch. Headlamp should flash HIGH beam for as long as the switch is pressed.
 - d. Check left and right turn signals.
 - e. Activate horn by pressing horn switch.
 - f. Turn ignition key switch to LOCK.

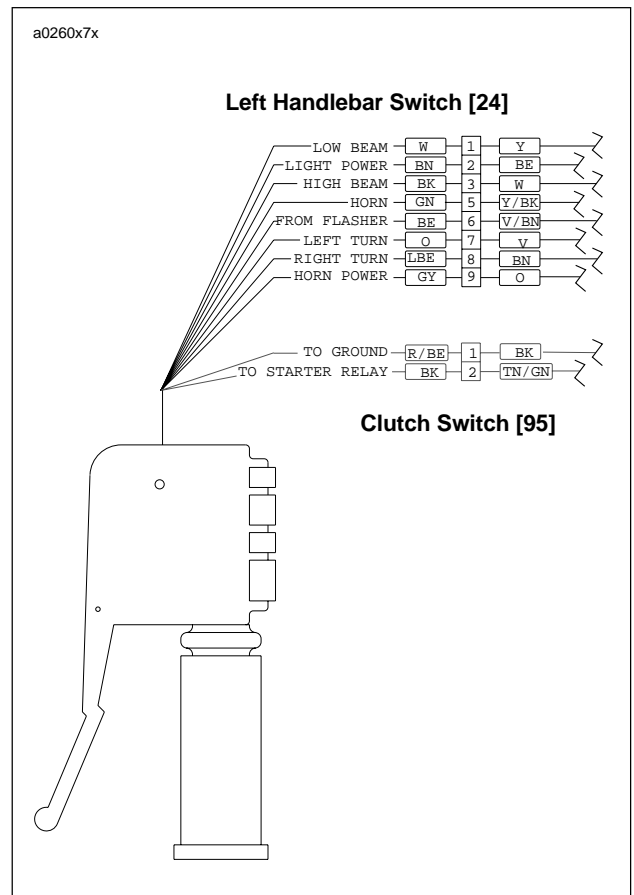

Figure 7-76. Left Handlebar Switch Connection

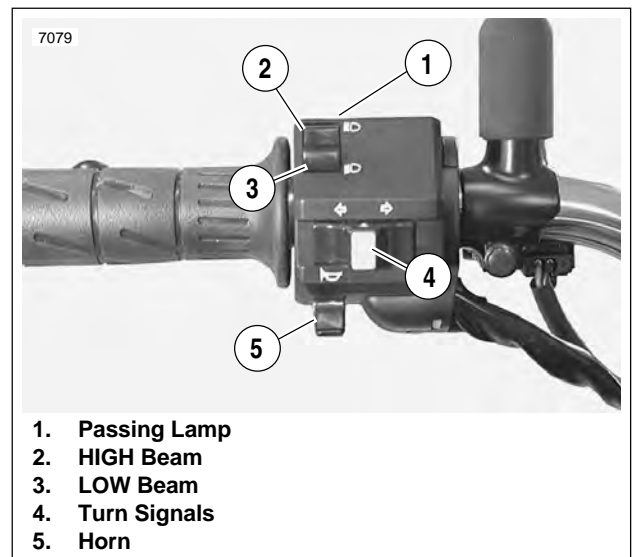

Figure 7-77. Left Handlebar Switches

REMOVAL

1. Pull bottom of horn forward slightly and remove nut (metric) from back of horn.
2. See [Figure 7-78](#). Detach Y/BK power wire and BK ground wire from terminal clips.
3. Remove horn from motorcycle.

INSTALLATION

1. See [Figure 7-78](#). Connect Y/BK power wire and BK ground wire to terminal clips.
2. Attach horn to bracket with nut (metric). Tighten nut to 25-33 **in-lbs** (2.6-3.7 Nm).
3. Check horn operation. If horn does not sound or fails to function satisfactorily, see [TROUBLESHOOTING](#).
 - a. Turn ignition key switch to IGN.
 - b. Press horn switch to activate horn.
 - c. Turn ignition key switch to LOCK.

TROUBLESHOOTING

1. If the horn does not sound or fails to function satisfactorily, check for the following conditions:
 - a. Discharged battery.
 - b. Loose, frayed or damaged wiring leading to horn terminal.
2. If battery has a satisfactory charge and wiring appears to be in good condition, test horn grounds and switch using voltmeter.
 - a. See [Figure 7-78](#). Remove Y/BK power and BK ground wires from terminal clips.
 - b. Connect voltmeter positive (+) lead to Y/BK wire.
 - c. Connect voltmeter negative (-) lead to ground.
 - d. Turn ignition key switch to IGN.
3. See [Figure 7-79](#). Depress horn switch and observe voltmeter reading.
 - a. If battery voltage is present, horn or horn grounding is faulty. If horn is faulty, replace unit as an assembly. The horn is not repairable.
 - b. If battery voltage is not present, either horn switch or wiring to horn is faulty. If horn switch is faulty, replace left handlebar switch. See [7.21 HANDLEBAR SWITCHES](#).

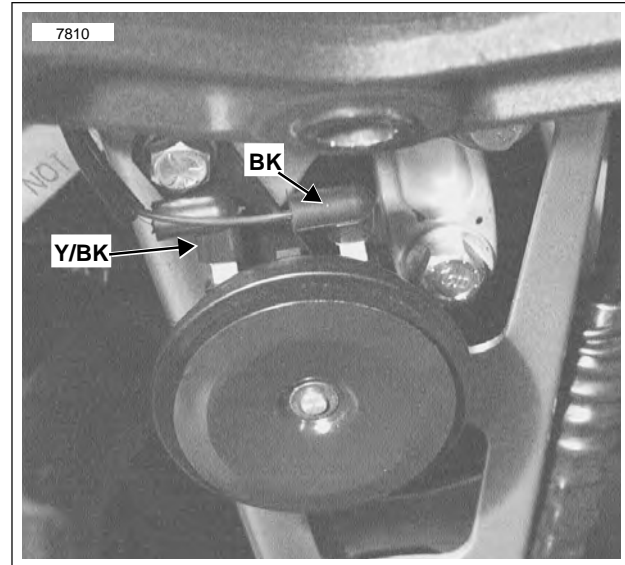

Figure 7-78. Horn Assembly

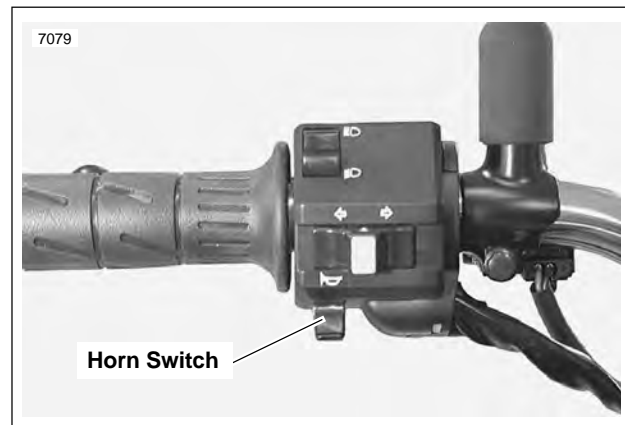

Figure 7-79. Horn Switch Location

GENERAL

See [Figure 7-80](#). The neutral indicator switch (1) is threaded into the transmission portion of the right crankcase half (2); it is immediately forward of the main drive gear shaft (3). The sprocket cover must be removed to test the switch. If switch requires replacement, secondary drive belt and transmission sprocket must also be removed; there is not enough clearance to allow the removal of the switch without first removing the transmission sprocket.

A pin on the shifter drum contacts the neutral indicator switch plunger, completing the neutral indicator circuit. The switch is not repairable. Replace the switch if it malfunctions.

For diagnostic information, see [Section 7.28 INDICATORS](#).

REMOVAL/INSTALLATION

1. Verify that the ignition key switch is turned to LOCK.
2. Remove front sprocket cover. See [2.23 SPROCKET COVER](#).
3. See [Figure 7-80](#). Place transmission in first gear. Remove two socket head screws (7) and lockplate (6).

CAUTION

Transmission sprocket nut has left-hand threads. Turn nut clockwise to loosen and remove from main drive gear shaft. Transmission sprocket nut will be damaged if turned counterclockwise to remove.

4. Remove transmission sprocket nut (5) from main drive gear shaft (3).
5. Remove transmission sprocket (4) (with secondary drive belt) from main drive gear shaft (3).
6. Remove wire lead from neutral indicator switch (1). Remove switch from right crankcase half (2).
7. Install **new** neutral indicator switch.
 - a. Apply a light coating of LOCTITE THREADLOCKER 243 (blue) to **new** neutral indicator switch (1) threads.
 - b. Install switch in crankcase. Tighten to 3-5 ft-lbs (4.0-6.8 Nm).
 - c. Connect wire lead to switch.
8. Install transmission sprocket (4) (with secondary drive belt) onto main drive gear shaft (3). See [6.16 TRANSMISSION SPROCKET](#).
9. Install sprocket cover. See [2.23 SPROCKET COVER](#).

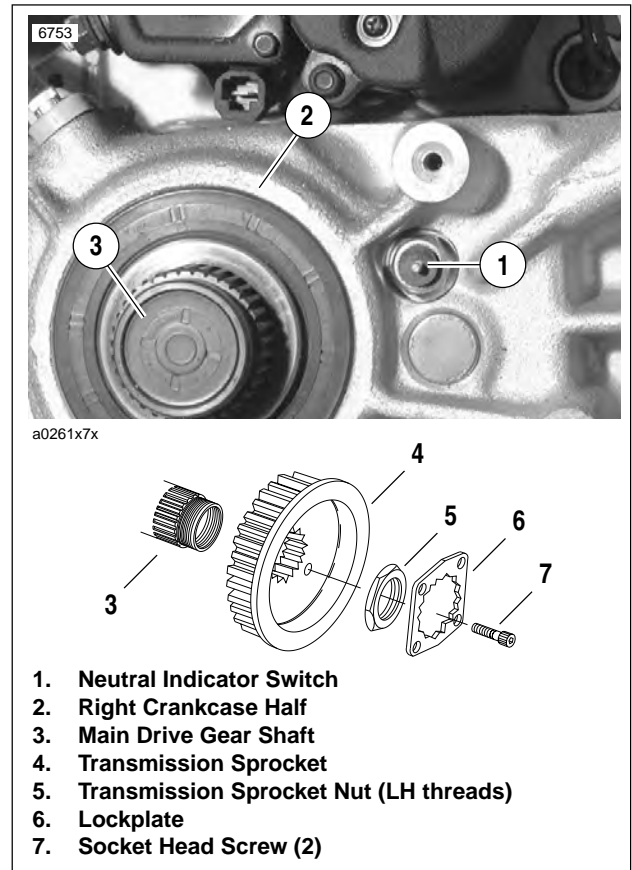

Figure 7-80. Neutral Indicator Switch

GENERAL

Buell motorcycles feature two components which protect the electrical system; Fuses and Circuit Breakers.

Fuses

See [Figure 7-81](#). The fuse block is on the right side of the frame under the seat. The block contains five replaceable fuses. Two spare fuses (4) are attached to the fuse block.

The lights (1) key switch (2) and system (3) fuses are each rated at 15 amperes. The ignition (5) and accessory (6) fuses are rated at 7.5 amperes.

Remove fuses by pulling them straight up and out of the fuse block. Inspect metal strip inside opaque plastic shell. A broken metal strip indicates a blown fuse. Always replace fuses with fuses of the same amp rating.

Always investigate the cause of blown fuses before replacing them. See your Buell dealer for more information.

Circuit Breakers

See [Figure 7-82](#). The 30 ampere main circuit breaker is under the seat next to the battery.

Since the circuit breaker is the automatic-reset type, the bimetallic breaker contacts automatically close (completing the circuit) once they have cooled down from the initial overload. If the overload condition still exists, the breaker contacts will again open to interrupt current flow. This opening and closing of the breaker contacts continues as long as the current circuit overload condition exists.

To replace the circuit breaker:

1. Remove seat. See [2.29 SEAT](#).
2. Disconnect battery negative cable from battery.
3. Remove acorn nuts, nuts with lock washers and wire leads from circuit breaker studs. Tag wire leads for ease of assembly.
4. Remove circuit breaker from circuit breaker bracket by carefully prying clip tab, located on left side, open and sliding circuit breaker out. NOTE: Bank Angle Sensor will require reinstallation if bracket is removed. See [7.5 BANK ANGLE SENSOR](#).
5. Install in the reverse order. Tighten screw (if bracket was removed) to 25-27 in-lbs (2.8-3.1 Nm). Tighten metal nut to 15-18 in-lbs (1.7-2 Nm). Tighten plastic acorn nuts to 1-3 in-lbs (0.1-0.3 Nm).

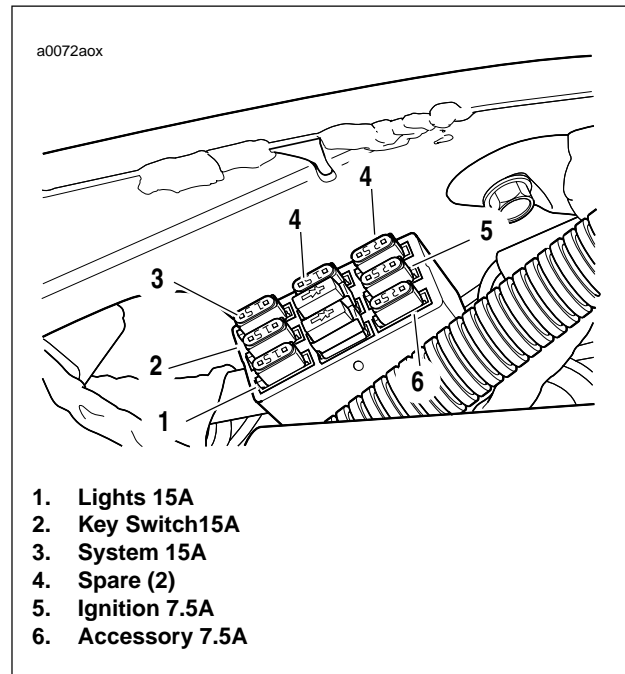

Figure 7-81. Fuse Block

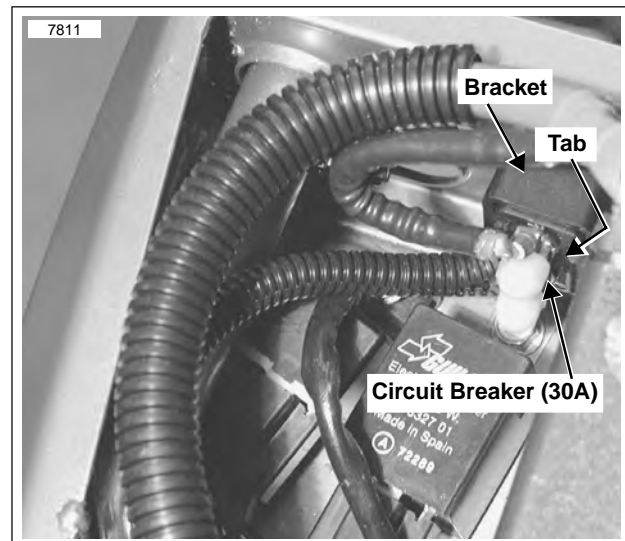

Figure 7-82. Circuit Breaker

GENERAL

The electronic speedometer consists of a speed sensor, function switch and the speedometer. The speed sensor is mounted on the right side of the transmission case, below the starter. The sensor circuitry is that of a Hall-Effect sensor that is triggered by the gear teeth of 5th gear on the transmission main shaft. The output from the sensor is a series of pulses that are interpreted by speedometer circuitry to control the position of the speedometer needle and the liquid crystal display (LCD) odometer display. The odometer mileage is permanently stored and will not be lost when electrical power is turned off or disconnected. The function switch allows switching, or "togglng" between the odometer and trip odometer displays. To zero the trip odometer, have the odometer display visible, press and keep the function switch depressed. The trip odometer mileage will be displayed for 2 to 3 seconds and then the mileage will return to 0 miles.

The odometer can display seven numbers to indicate a maximum of 999999.9 miles. The trip odometer can display five numbers for a maximum of 9999.9 miles.

Circuitry in the speedometer also conditions the sensor input to provide an input to the turn signal canceller.

Replace the speedometer if the unit is not working properly. However, before replacing a component, check that the problem is not caused by a faulty cable or loose wire connection.

DIAGNOSTICS

Blast Models have a speedometer with self-diagnostic capabilities.

General

The reset switch is used to change the odometer display between mileage and trip values and to reset the trip odometer. It is also used to identify the speedometer calibration and to enter the diagnostic mode, clear diagnostic codes and exit the diagnostic mode.

Diagnostic Mode

The diagnostic mode is entered by turning the ignition switch from OFF to ON while holding the reset switch in. The normal power-up sequence will occur before entering the diagnostic mode. Diagnostic codes set during this power-up sequence will be stored as well.

NOTE

Make sure no Diagnostic Codes are indicated before reset is held in for more than 5 seconds or diagnostic information will be lost.

When in the diagnostic mode, the odometer will display the first diagnostic code. When the trip switch is pressed again, the next code will be shown. If the trip switch is pressed for more than 5 seconds at any time while in the diagnostic mode, the **diagnostic code displayed will be erased**.

There are seven different diagnostic codes available. They are as follows:

- d01** - Speed sensor power output shorted low
- d02** - Speed sensor power output shorted high or open
- d03** - Not used
- d04** - Not used
- d05** - Speed sensor return shorted high
- d06** - Speed sensor return shorted low
- d07** - Not used
- d08** - Speedometer power over voltage
- d09** - Speed output shorted high
- d10** - Speed output shorted low or open
- CAL XX** - Speedometer application calibration number:
14 = domestic

When in the diagnostic mode, all codes are displayed in sequence from d01 to d10.

As a code appears in the display (for instance d02), it will read "d02SEt" of set or "d02CLr" if clear.

The diagnostic mode is exited either by turning ignition from ON to OFF to ON again without depressing the reset switch or if a speed signal greater than 5 m.p.h. is detected.

Diagnostics cannot be performed if a system voltage is less than 9 VDC or greater than 16 VDC. The only exception is **d08** which is set when the system voltage is greater than 16 VDC.

After all diagnostic codes are displayed, the speedometer calibration number is displayed (**CAL14**).

Reset Switch Replacement

1. Remove odometer reset boot from instrument panel.
2. Unscrew bezel ring from reset switch and pull switch out from behind instrument panel.
3. Cut wires from switch.
4. Install **new** switch wires using SEALED WIRE SPLICES.
5. Position **new** reset switch in squared boss Behind instrument panel.
6. Install bezel inside of rubber boot.
7. Install rubber boot/bezel assembly to odometer reset switch.

REMOVAL

1. See [Figure 7-83](#). Remove two fasteners holding dash panel to upper triple clamp.
2. Unplug connector [20]. Cut and remove cable tie.
3. The rubber mount is a tight fit in the dash panel. To remove the speedometer without damaging the dash panel:
 - a. See [Figure 7-84](#). Loosen screw until head is approximately $\frac{1}{8}$ inch above the back surface of the dash.
 - b. Liberally apply glass cleaner around circumference of rubber mount.
 - c. See [Figure 7-85](#). Position dash and speedometer on edge of hard surfaced bench and apply even pressure to dash to open a gap between the speedometer and dash.
 - d. Remove two screws that secure speedometer to rear of dash panel.
 - e. Apply more glass cleaner in gap and work speedometer free from dash.
4. Depress tab and remove speedometer connector [39].

INSTALLATION

1. Install connector [39] on back of speedometer.
2. Lubricate rubber mount with glass cleaner and insert speedometer into dash panel.
3. Install speedometer to dash panel with two screws in back of dash panel.
4. Connect connector [20] and replace cable tie to adjacent wire bundle.
5. Apply LOCTITE THREADLOCKER 243 (Blue) to first few threads of dash panel mounting screws.
6. Position dash panel in mounting position on upper triple clamp and install two screws. Tighten screws to 30-36 **in-lbs** (3-4 Nm).

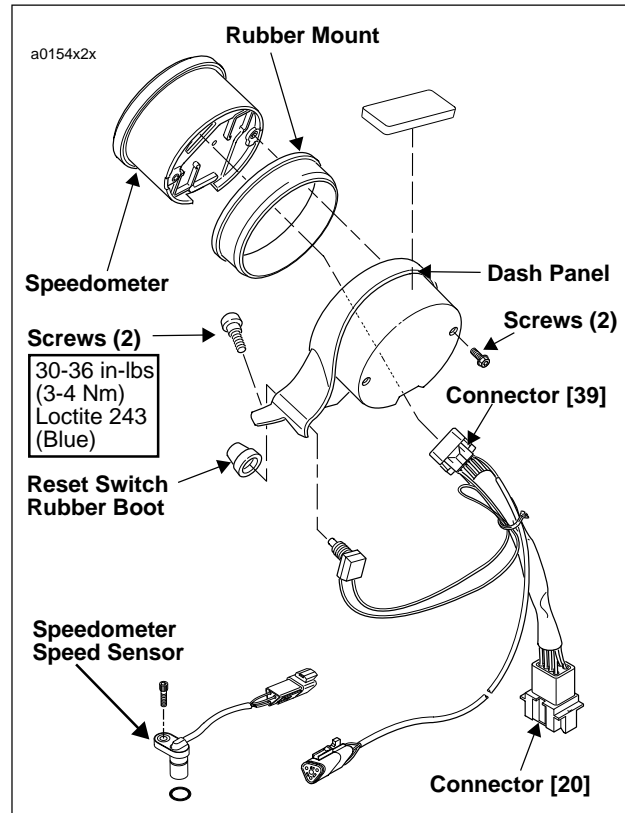

Figure 7-83. Speedometer



Figure 7-84. Speedometer Fasteners

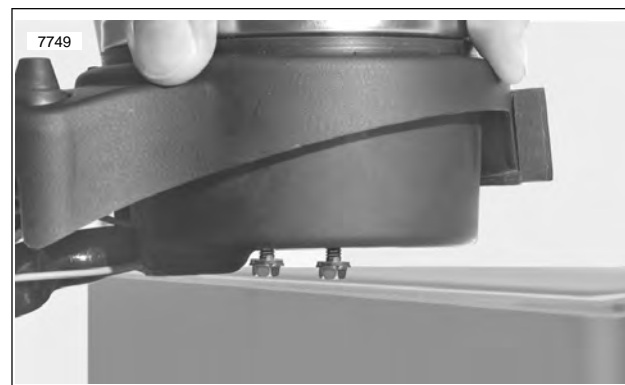

Figure 7-85. Removing Speedometer

REMOVAL

1. Remove seat. See 2.29 SEAT.
2. See Figure 7-86. Locate and unplug speedometer sensor 3-place connector [65]. Connector is located in the right side frame cavity.
3. See Figure 7-87. Locate speed sensor on engine case right side, to the rear of the starter solenoid.
4. Remove speed sensor mounting screw.
5. Remove sensor with o-ring from engine case cavity and pull wires down through frame.

INSPECTION

NOTE

Debris on speedometer sensor can result in false speedometer reading, especially during break-in. Always clean and troubleshoot speedometer sensor and verify proper operation before replacing speedometer. See Speedometer Sensor Test in next section.

Clean any debris from speedometer sensor.

INSTALLATION

1. Install speedometer sensor in engine case.
2. Install screw and tighten to 80-100 **in-lbs** (9-11.3 Nm).
3. Connect connector [65] in right side frame cavity.
4. Install seat. See 2.29 SEAT.

WARNING

After installing seat, pull upward on front of seat to be sure it is locked in position. If seat is loose, it could shift during vehicle operation, causing loss of control of vehicle and death or serious injury.

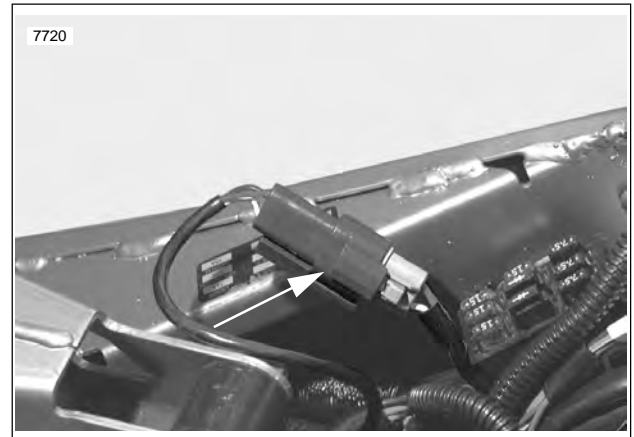

Figure 7-86. Speedometer Sensor Connector [65]

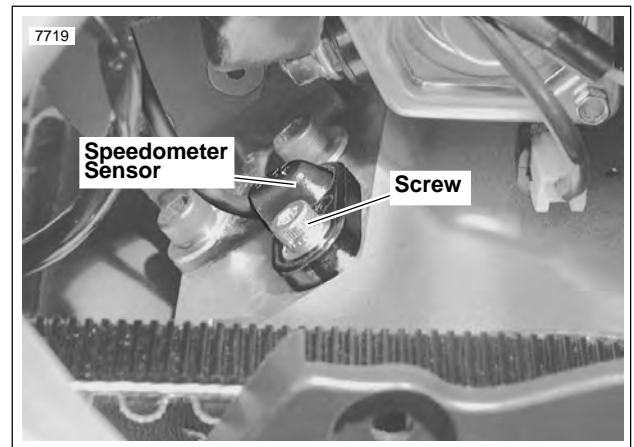

Figure 7-87. Speedometer Sensor

GENERAL

See [Figure 7-88](#). Use the SPEEDOMETER TESTER (Part No. HD-41354) for speedometer diagnostics. These diagnostics may include:

- Checking speedometer operation.
- Testing speedometer needle sweeping action.

The tester generates a simulated speedometer sensor signal. This signal aids in determining whether speedometer replacement is necessary. It can also be used to simulate running engine conditions for ignition system troubleshooting.

NOTES

- Use the following procedures in conjunction with the manual supplied with the speedometer tester.
- Test results may be inaccurate if tester battery is low.

TESTING

NOTE

The SPEEDOMETER TESTER (Part No. HD-41354) cannot be used to verify the calibration of a speedometer and it will not verify the speedometer's function to support legal proceedings. Its purpose is to verify speedometer function when performing service diagnosis or repair. It can also assist in determining if speedometer replacement is necessary.

Speedometer Operation Test

1. See [Figure 7-89](#). Locate the 3-place Deutsch connector [65] for the speedometer sensor to right of battery and disconnect.
2. Attach speedometer tester connector to speedometer sensor connector.
3. Place speedometer tester power switch in the ON position. Place signal switch in the OUT position.
4. Turn vehicle ignition switch ON.
5. Begin test.
 - a. Press ENTER on the tester keypad.
 - b. Enter a frequency from [Table 7-3](#). Note that different markets use different frequencies.
 - c. Verify that speedometer display reads the corresponding speed. To change the test frequency, press CLEAR to cancel and enter the new frequency. Press ENTER to begin and reverify.

NOTE

The speedometer should be accurate within 0-4 MPH (0-6.5 KPH).

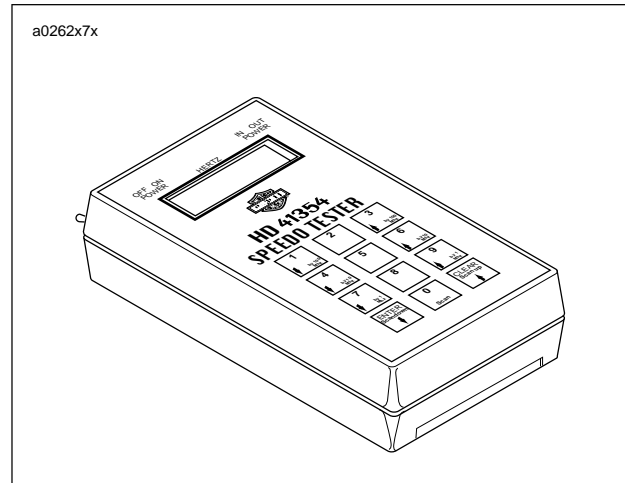

Figure 7-88. Speedometer Tester

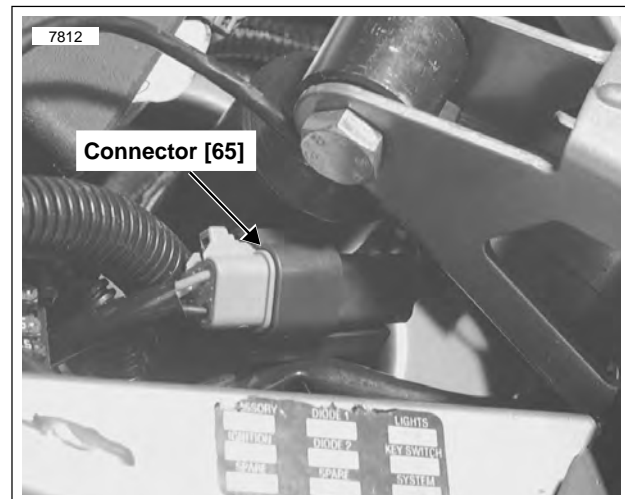

Figure 7-89. Speedometer Sensor Connector [65]

Table 7-3. Speedometer Test Frequency in Hertz (Hz)

MARKET	20 MPH (30 KPH)	40 MPH (60 KPH)	60 MPH (100 KPH)	80 MPH (130 KPH)
USA	606	1207	1803	2392
CAN	606	1208	1804	2393

Speedometer Needle Sweep Test

The tester's sweep function moves the speedometer needle through the full range of movement. This allows for testing the smoothness of operation and checking for hesitancy or a stuck needle.

1. See [Figure 7-89](#). Disconnect speedometer sensor connector. Attach speedometer tester connector to speedometer sensor connector.
2. Place speedometer tester power switch in the ON position. Place signal switch in the OUT position.
3. Turn vehicle ignition switch ON.
4. Begin test by pressing 0 on the tester keypad, then pressing ENTER. The tester will scan for two seconds, then the tester will put out a 1 Hz signal.
5. Select a test range.
 - a. Press 2 to select LO range (1-20 Hz).
 - b. Press 5 to select CEN range (21-999 Hz).
 - c. Press 8 to select HI range (1000-20,000 Hz).
6. After selecting a range, use the corresponding arrow keys to accelerate through the range. As you move through the speed range, check for smooth needle movement.
 - a. If testing LO range, press 1 or 3.
 - b. If testing CEN range, press 4 or 6.
 - c. If testing HI range, press 7 or 9.

Speedometer Sensor Test

If the speedometer is inoperative, but backlighting and odometer work, the speedometer sensor may not be working.

See [Figure 7-90](#). Fabricate a test harness using the following parts.

- Two Deutsch 3-place socket housings (Part No. 72113-94BK).
- Deutsch 3-place pin housing (Part No. 72103-94BK).
- Six lengths of 18 gauge wire, each 6.0 in. (15 cm) long.
- Six socket terminals (Part No. 72191-94).
- Six pin terminals (Part No. 72190-94).
- Two secondary locks (socket) (Part No. 72153-94).
- Two secondary locks (pin) (Part No. 72143-94).

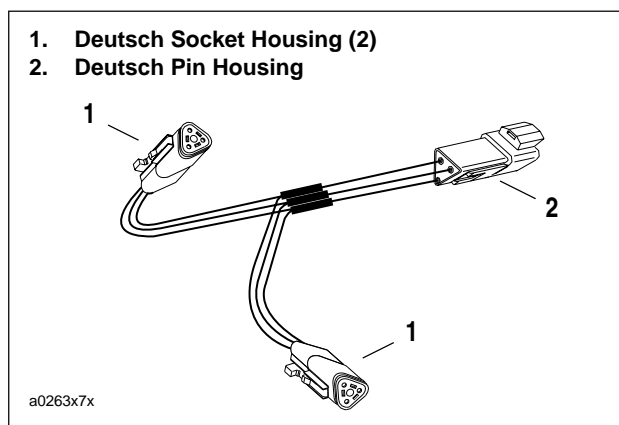

Figure 7-90. Test Harness

Before attempting the actual speedometer sensor check, two system checks must be made. Install the test harness at the speed sensor connector [65]. See [Figure 7-90](#).

- Test for voltage to sensor by checking for 8-12 VDC on red wire in connector [65B].
 - Then check for continuity to ground on black wire in connector [65B].
1. Raise rear wheel off floor using REAR WHEEL SUPPORT STAND (Part No. B-41174).
 2. Install the test harness between the speedometer sensor connectors [65A] and [65B].
 3. Place speedometer tester power switch in the ON position. Place signal switch in the IN position.
 4. Plug the speedometer tester into the test harness. Turn vehicle ignition switch ON.
 5. Press ENTER on the tester keypad.
 6. Rotate the motorcycle's rear wheel.
 - a. If reading on speedometer tester changes as wheel is rotated, speedometer sensor is OK.
 - b. If reading does not change, speedometer sensor is suspect. Remove sensor and check for debris, clean, replace sensor and retest. If still non-functional, install a known, good speedometer sensor and test again for proper operation.

SPEEDOMETER TROUBLESHOOTING CHART DIAGNOSTIC NOTES: The reference numbers below correlate with those on the diagnostic flow charts found on the following pages.

- ① To enable diagnostic mode: press odometer reset switch and turn ignition/key switch to ON.
- ② To clear codes: depress and hold reset switch for 5 seconds with set code displayed.
- ③ To return speedometer to normal operating state: cycle ignition/key switch.
- ④ Remove seat. See [2.29 SEAT](#).
- ⑤ Test results may be inaccurate if tester battery is low.
- ⑥ Refer to [7.27 SPEEDOMETER PERFORMANCE CHECK](#).
- ⑦ Sensor can also be tested with Speedometer Tester (HD-41354) and Test Harness. See [SPEEDOMETER SENSOR TEST](#).
- ⑧ Remove sensor and check for accumulation of debris on sensor; if debris is not present, replace sensor. If debris is present, clean sensor and repeat test. Replace sensor as required. See [7.26 SPEEDOMETER SENSOR](#).
- ⑨ Sweep tool has frequency jumps in full scale sweeps. Perform sweep in 3 stages as described in speedometer tester manual.
- ⑩ Disconnecting speed sensor or install speedometer sensor will cause code **d02** to set.

Speedometer Test: Chart 1

ODOMETER, TRIP ODOMETER AND RESET SWITCH TESTING

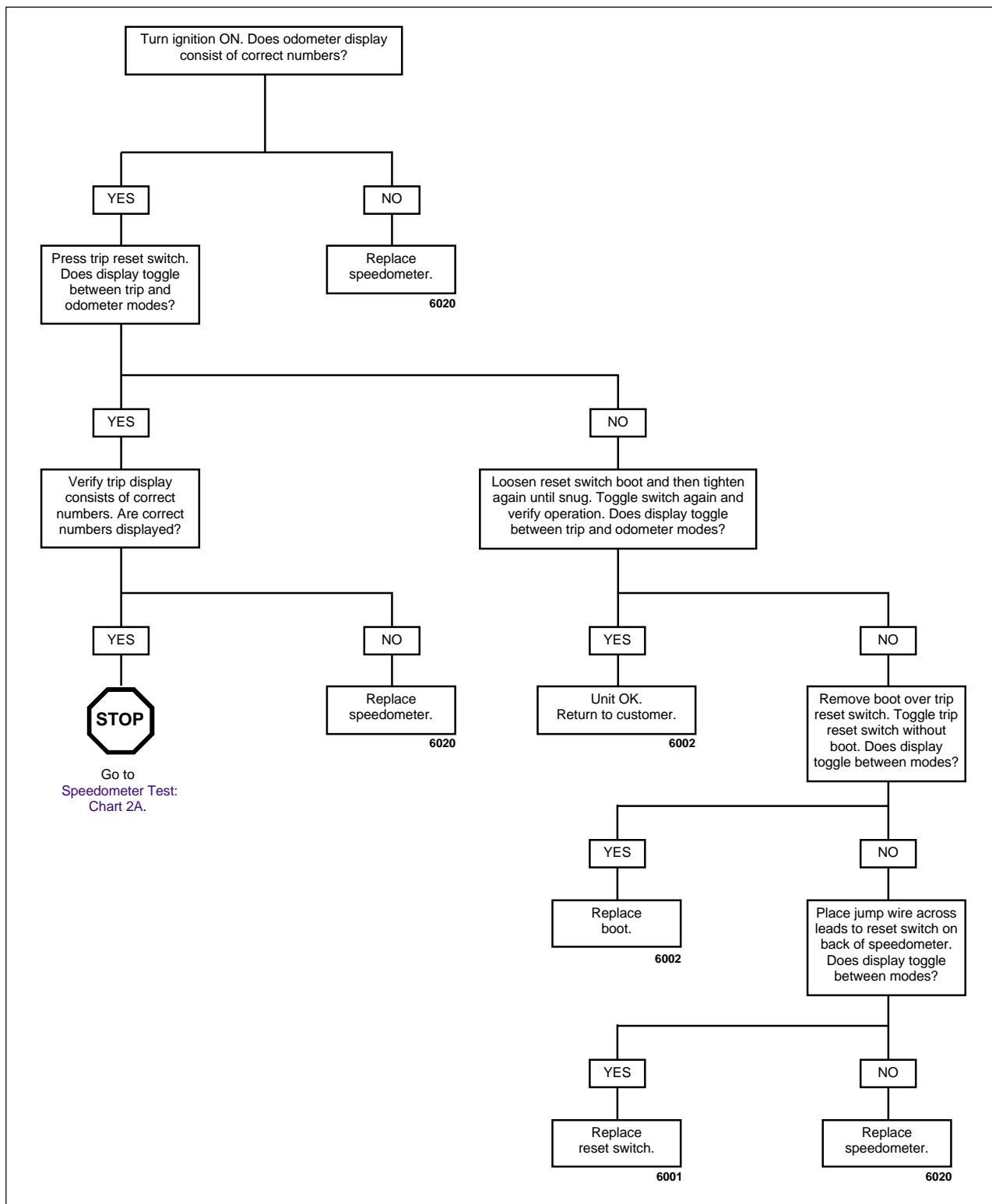

Figure 7-91. Speedometer Test Chart 1

Speedometer Test: Chart 2A

INOPERATIVE, INACCURATE OR ERRATIC SPEEDOMETER

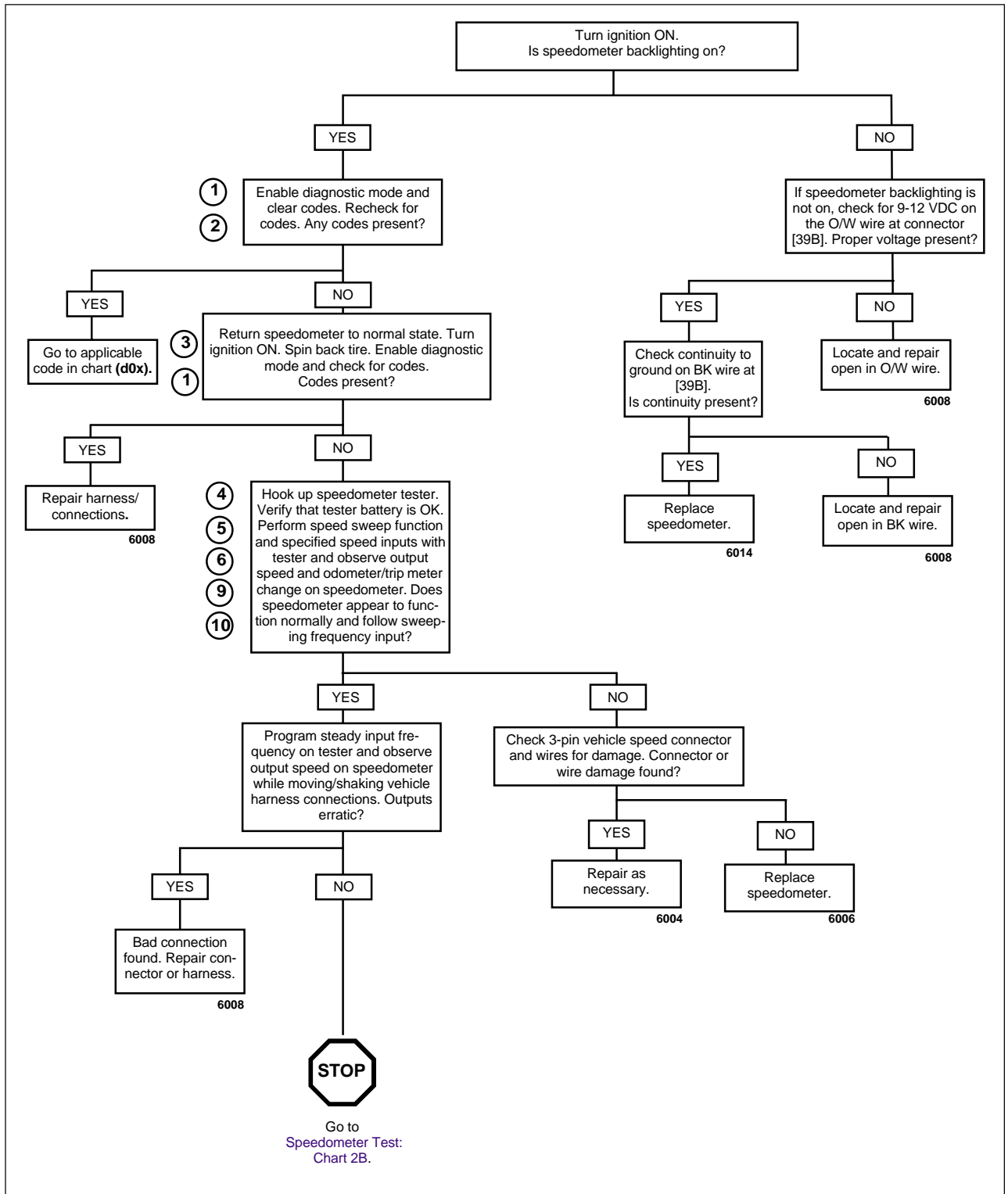

Figure 7-92. Speedometer Test Chart 2A

Speedometer Test: Chart 2B

INOPERATIVE, INACCURATE OR ERRATIC SPEEDOMETER

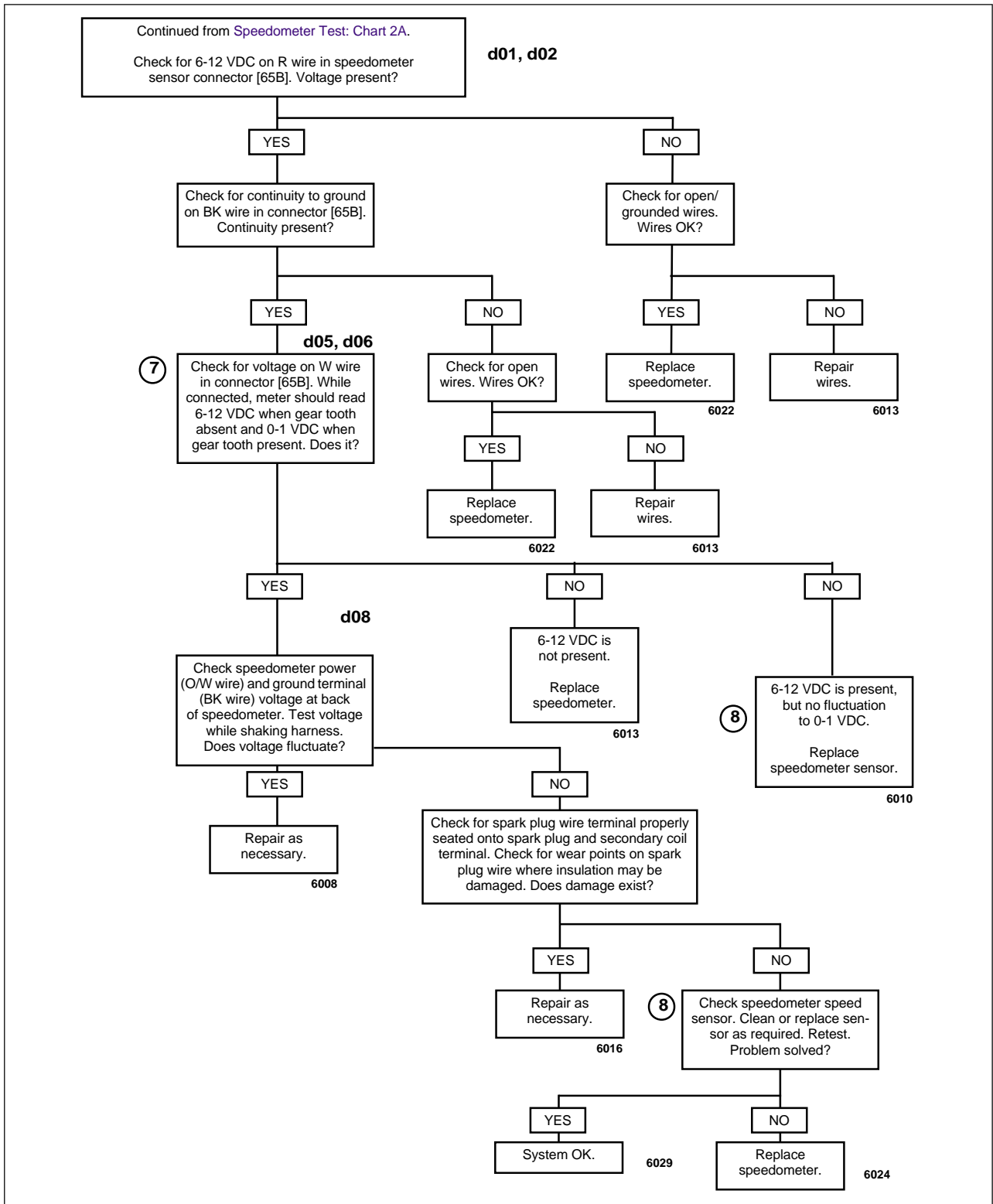

Figure 7-93. Speedometer Test Chart 2B

GENERAL

Indicators are Light Emitting Diodes (LEDs) located in the speedometer. LEDs are non-repairable. Replace the speedometer if an LED fails.

DIAGNOSTICS

See diagnostic tables below.

INDICATOR LIGHTS

Problem: Light(s) inoperative.

Follow the diagnostic flow charts below. If replacement is necessary, replace speedometer. See 7.25 ELECTRONIC SPEEDOMETER.

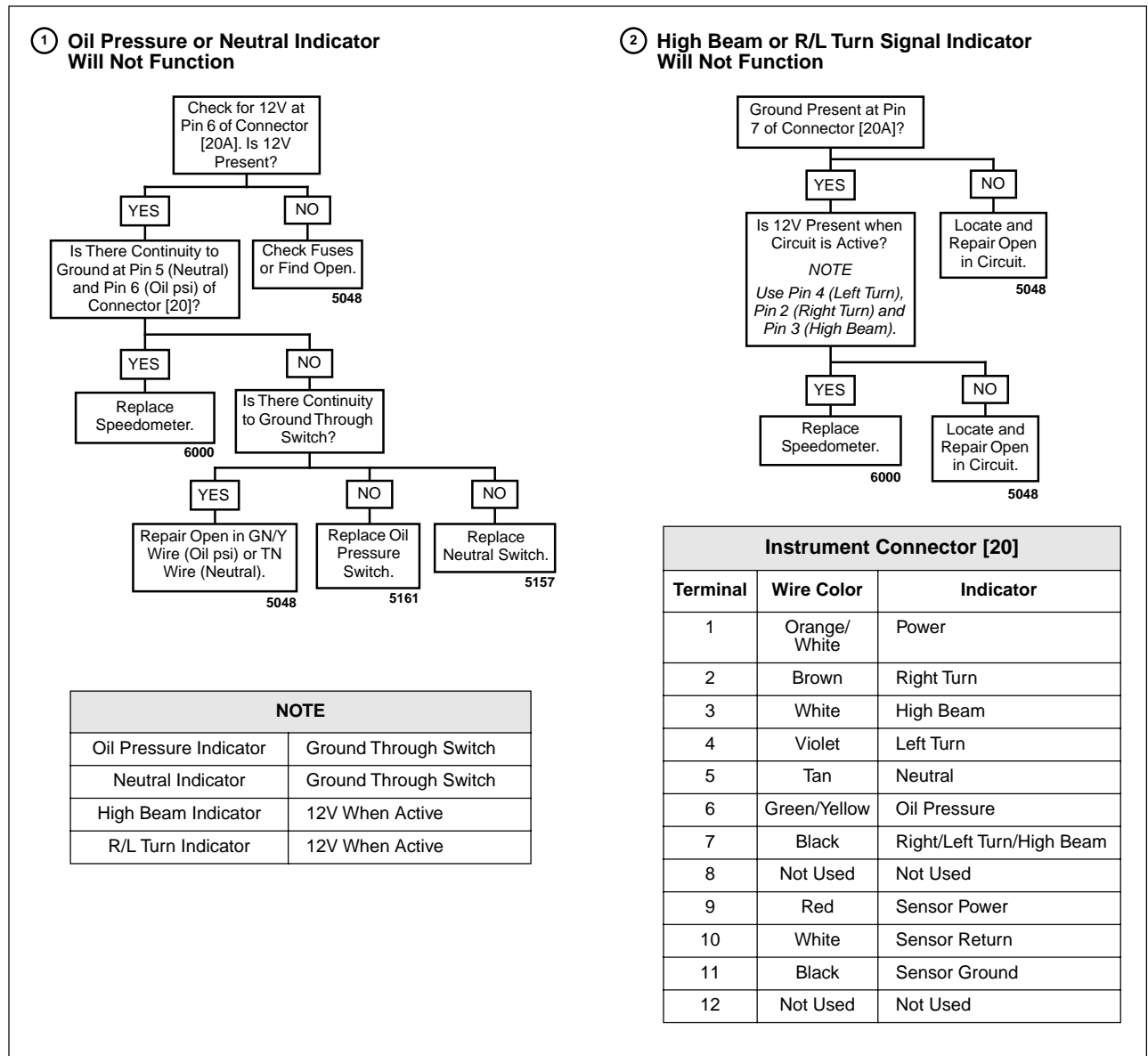

Figure 7-94. Diagnostics

GENERAL

The main wiring harness runs from the front of the motorcycle (behind dash) to the rear of the frame tray under the seat where it connects to the tail lamp/turn signal mini-harness.

REMOVAL

1. Remove seat. See 2.29 SEAT.

⚠ WARNING

To protect against shock and accidental start-up of vehicle, disconnect the negative battery cable before proceeding. Inadequate safety precautions could result in death or serious injury.

⚠ WARNING

Always disconnect the negative cable first. If the positive cable should contact ground with the negative cable installed, the resulting sparks may cause a battery explosion which could result in death or serious injury.

2. Disconnect battery cables, negative cable first.
3. Remove battery. See 7.16 BATTERY.
4. Remove fuel tank. See 4.2 FUEL TANK COVER/FUEL TANK.
5. Remove windscreen. See 2.27 WINDSCREEN.
6. Remove headlamp housing and disconnect connector [38]. See 7.17 HEADLAMP.
7. Note location of cable ties and cut three cable ties on frame backbone that secure main wiring harness to frame. Disconnect harness from T-studs.
8. Disconnect speedometer connector [39].
9. Disconnect right and left handlebar switch connectors [22] and [24], front brake switch blade connectors [170] and clutch switch connector [95].
10. Tag and disconnect right and left front turn signal bullet connectors.
11. Disconnect ignition switch connector [33].
12. Note location of cable tie and cut cable tie on horn wire and remove two blade connectors [122] from horn.
13. See Figure 7-95. Unhook connector [10] from the T-stud on the left side of the frame backbone.
14. Note location of cable tie and cut cable tie on ignition coil and TP Sensor/Auto-Enrichener and Ignition Module harness.
15. See Figure 7-96. Disconnect ignition coil connector [83] at coil.
16. See Figure 7-97. Disconnect TP Sensor/Auto-Enrichener connector [88] under frame backbone.
17. Disconnect starter connector [128] at starter solenoid.
18. See Figure 7-95. Disconnect ignition connector [10] on left side of frame backbone.
19. Feed harness through frame and upper tie bar mount.

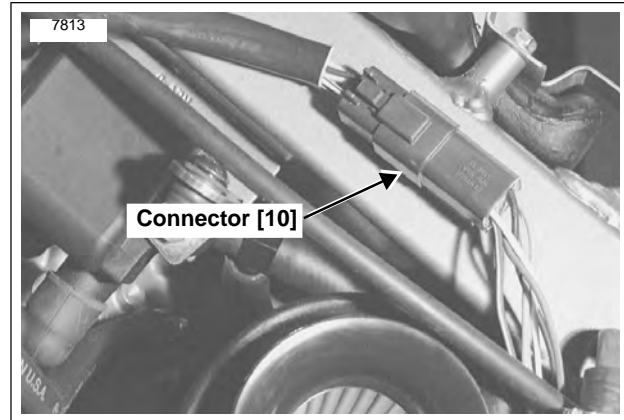

Figure 7-95. Ignition Connector [10]

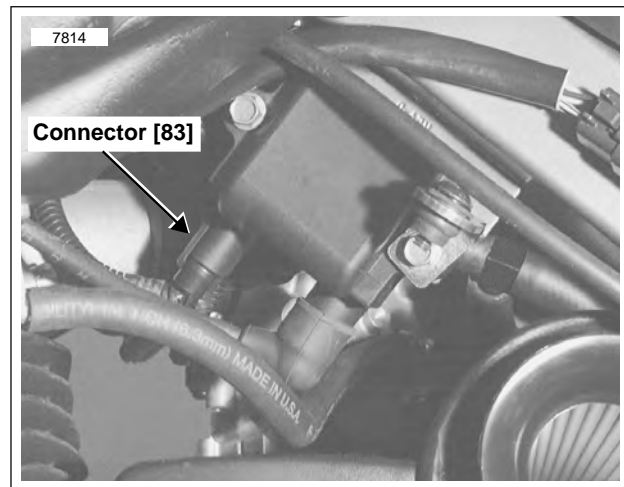

Figure 7-96. Coil Connector [83]

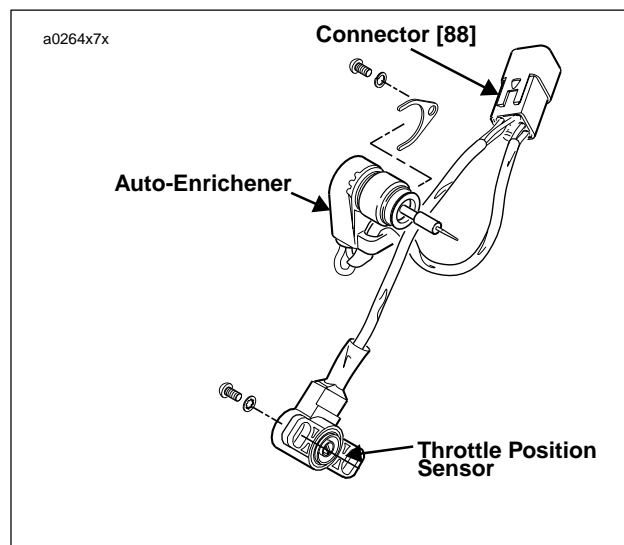

Figure 7-97. TP Sensor/Auto-Enrichener Connector [88]

20. Remove nut and clamp that secures oil hoses and wiring harness on right side of motorcycle.
21. Disconnect Neutral Switch bullet connector [172].
22. Disconnect speed sensor connector [65] located in frame tray on right side.
23. Disconnect side stand switch connector [60] above swing arm.
24. Disconnect oil pressure switch connector [120].
25. Disconnect rear brake line switch connector [121] located above swingarm on right side of motorcycle.
26. See [Figure 7-99](#). Unplug flasher relay connector [30] and starter relay connector [123] located in frame tray on right hand side.
27. Unplug system relay connector [171] located in frame tray on left side.
28. See [Figure 7-99](#). Disconnect positive (+) wire from battery on circuit breaker (upper stud).
29. Disconnect tail lamp/turn signal mini harness connector [7] located under seat.
30. Unhook fuse block.
31. Note location, and cut two zip ties on wire to frame and wire on voltage regulator mount. Disconnect voltage regulator wire and wire attached to frame.
32. Pull main wiring harness out through rear of frame.

INSTALLATION

1. Feed main wiring harness through frame from back to front.
2. See [Figure 7-99](#). Connect flasher relay connector [30] to flasher relay and starter relay connector [123] to starter relay.
3. Connect system relay connector [171] to system relay.
4. Install fuse block.
5. Connect positive (+) wire to circuit breaker. Tighten metal nut to 15-18 **in-lbs**. Tighten plastic acorn nut to 1-3 **in-lbs** (0.1-0.3 Nm).
6. Feed negative (-) wire across frame and connect to voltage regulator mount and frame. Use two cable ties to secure wires.
7. See [Figure 7-98](#). Mate speed sensor connector [65]. Tuck excess harness into right frame pocket.
8. Connect two blade terminals to stoplight switch above swingarm.
9. Mate side stand switch connector [60] located above swingarm. Cable tie wires.
10. Install starter connector [128] located under starter solenoid.
11. Install neutral switch bullet connector [172].
12. Install oil pressure switch connector [120] to oil pressure switch. Route wire around oil pump.
13. Install hose clamp around hoses and oil pressure switch and neutral switch wires. Secure clamp with **new** lock-nut.
14. Attach main wiring harness to T-studs.
15. Feed wire harness through upper tie bar mount in two bundles.

16. See [Figure 7-100](#). Mate TP Sensor/Auto-Enrichener connector [88] and secure with cable tie.
17. Install connector [83] to coil and secure with cable tie.

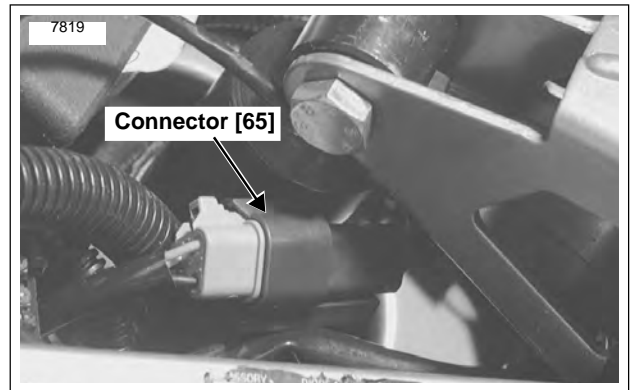

Figure 7-98. Speed Sensor Connector [65]

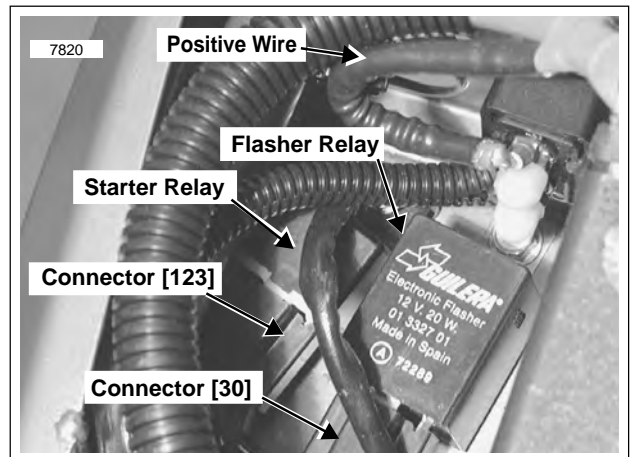

Figure 7-99. Flasher Relay Connector [30]

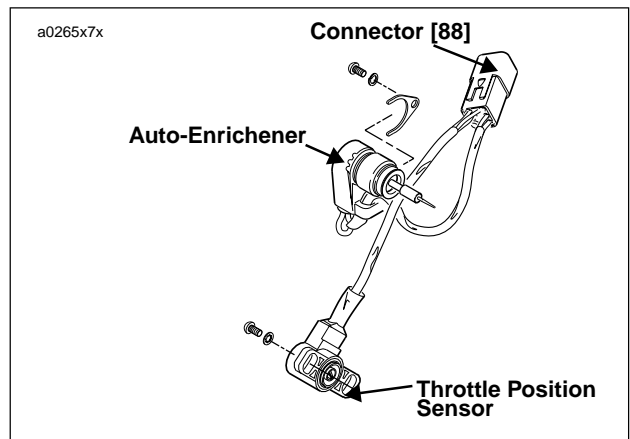

Figure 7-100. TP Sensor/Auto-Enrichener Connector [88]

HOME

18. See [Figure 7-95](#). Mate ignition module connector [10] and attach to T-stud on left side of frame backbone.
19. Feed longer bundle at front through frame hole to left side of motorcycle. Attach harness to T-stud.
20. Hook right side of harness to two T-studs on right side of motorcycle.
21. Mate right handlebar switch connector [22], front brake lamp switch connector [170]. Secure wires with cable ties.
22. Mate left handlebar switch connector [24] and clutch switch connector [95]. Secure wires with cable ties.
23. Connect speedometer connector [39].
24. Mate ignition switch connector [33].
25. Install left and right front turn signal bullet connectors as marked during removal.
26. See [Figure 7-102](#). Feed horn wires through frame hole on right side and install connector [122] to horn. Cable tie wires to isolator mount.
27. Cable tie main wiring harness to frame backbone with three cable ties.
28. Connect headlamp connector [38] and install headlamp housing. See [7.17 HEADLAMP](#).
29. Install windscreen with four screws and washers. See [2.27 WINDSCREEN](#).
30. Install fuel tank. [4.2 FUEL TANK COVER/FUEL TANK](#).

WARNING

Always connect the positive battery cable first. If the positive cable should contact ground with the negative cable installed, the resulting sparks could cause a battery explosion which could result in serious injury or death.

31. Install battery and reconnect battery cables, positive cable first. See [7.16 BATTERY](#).

WARNING

After installing seat, pull upward on front of seat to be sure it is locked in position. If seat is loose, it could shift during vehicle operation and startle the rider, causing loss of control which could result in death or serious injury.

32. Install seat. See [2.29 SEAT](#).

WARNING

Check for proper tail lamp, turn signal and headlamp operation before riding motorcycle. Visibility is a major concern for motorcyclists. Failure to have proper tail lamp, turn signal and/or headlamp operation could result in death or serious injury.

33. Check for proper operation of headlamp, turn signals, brake lamp and starting, charging and ignition systems.

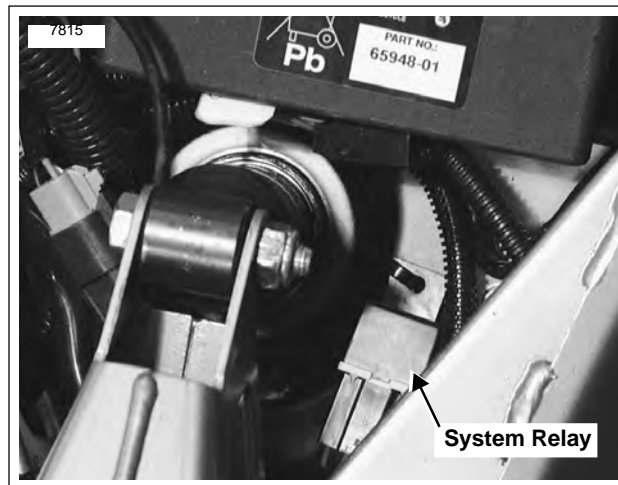

Figure 7-101. System Relay

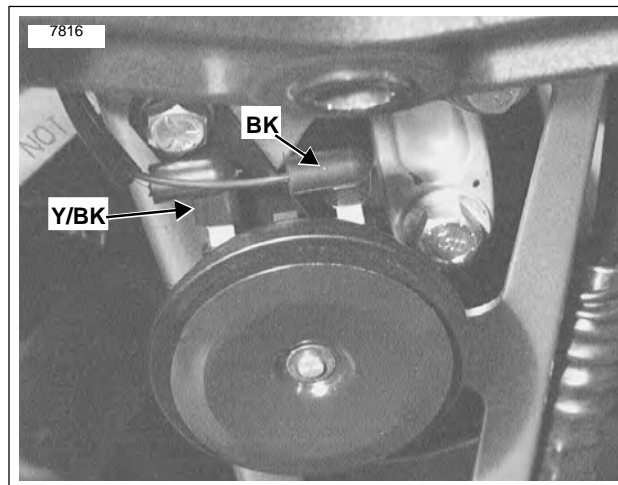

Figure 7-102. Horn Connector [122]

Table Of Contents

SUBJECT	PAGE NO.
Appendix A-Tools	A-1
Appendix B-Wiring	B-1
Appendix B-Wiring Diagrams	B-7
Appendix C-Metric Conversions	C-1

APPENDICES