

2007 BUELL P3

SERVICE MANUAL

Part Number 99492-07Y

Section 1: Maintenance

Section 2: Chassis

Section 3: Engine

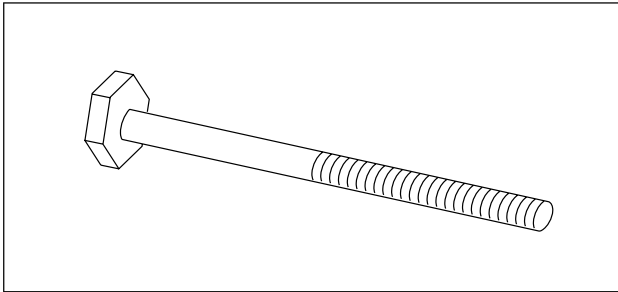
Section 4: Fuel System

Section 5: Starter

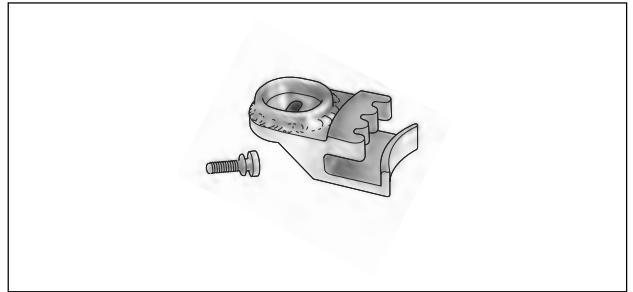
Section 6: Drive/Transmission

Section 7: Electrical

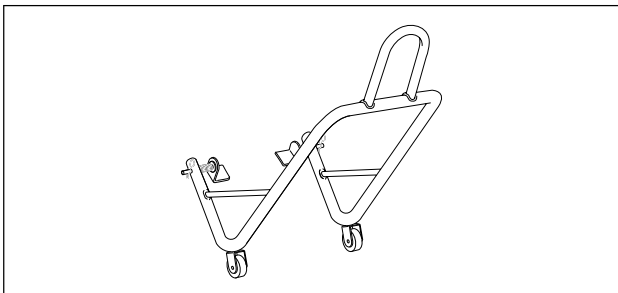
Appendix



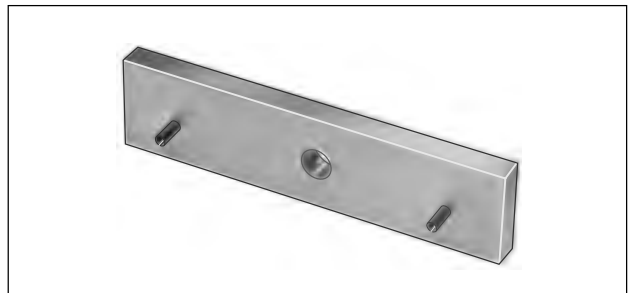
Part No. B-35316-5 12 Inch Bolt.
Used with Part No. HD-39302.



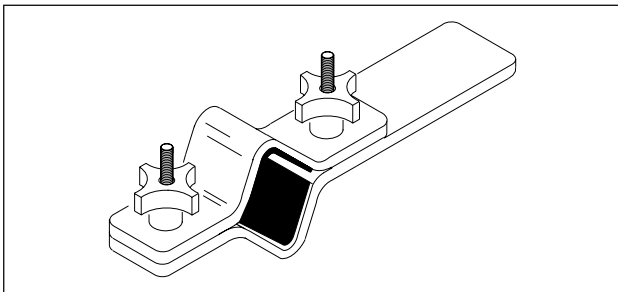
Part No. B-43982 Sprocket Locking Tool



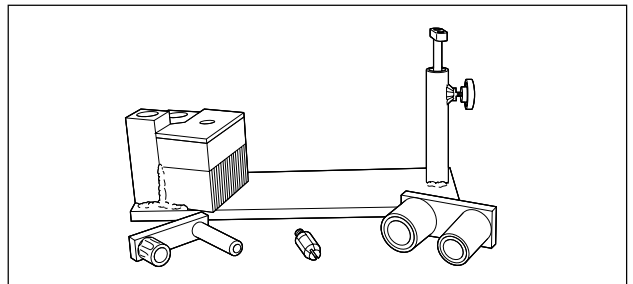
**Part No. B-41174 Rear Wheel Support Stand and
Part No. B-41174-2 Replacement Pad.**



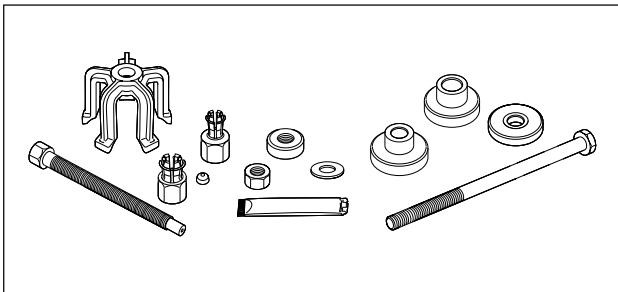
Part No. B-43983 Main Drive Gear Cross Plate.
Used with Part No. HD-35316A.



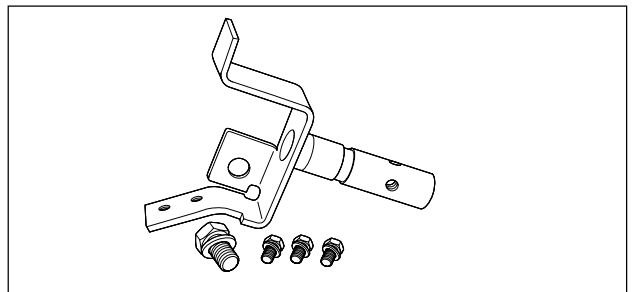
Part No. B-41177 Front Fork Holding Tool



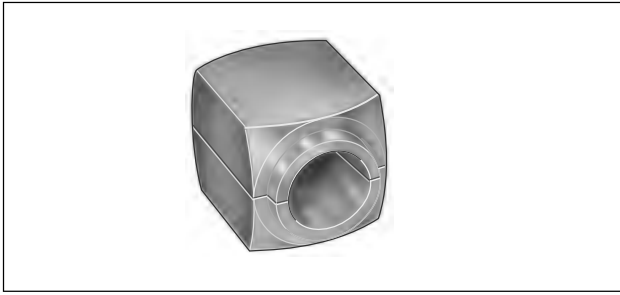
Part No. B-43985 Transmission Remover/Installer



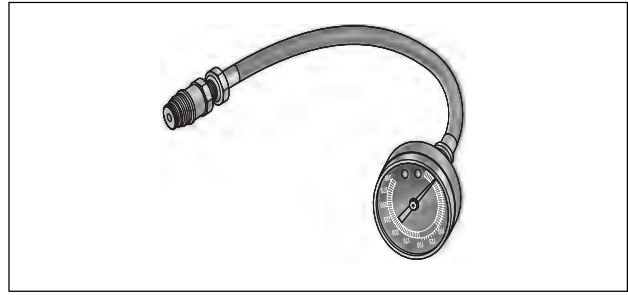
Part No. B-43933 Wheel Bearing Remover/Installer.
Use with Part No. HD-44060.



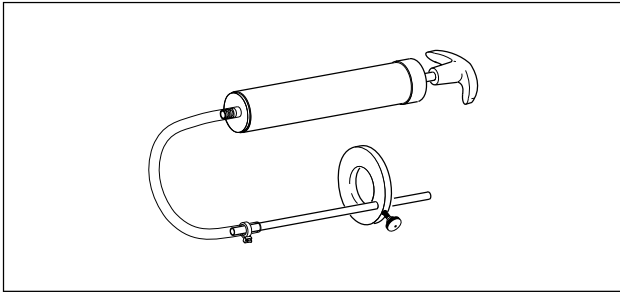
Part No. B-43987 Engine Cradle
Used with HD-42310



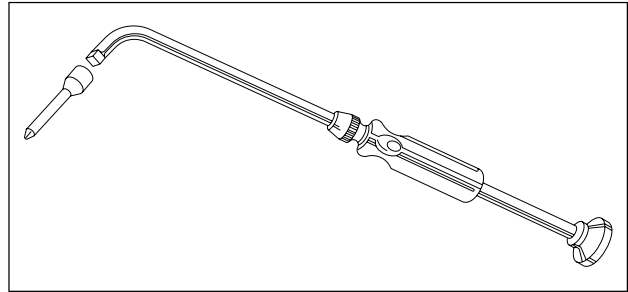
Part No. B-43991 Fork Seal/Bushing Driver



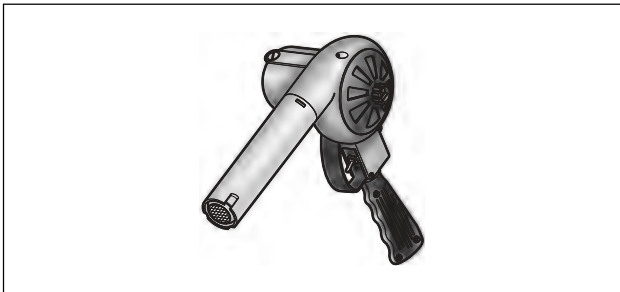
Part No. HD-33223-1 Cylinder Compression Gauge



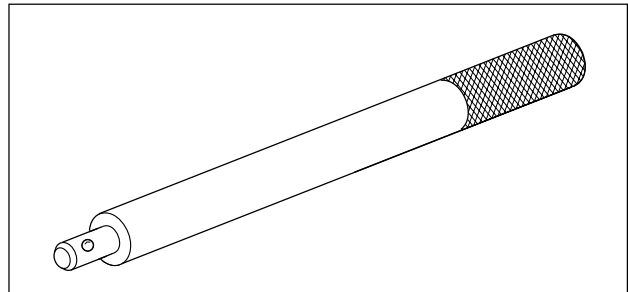
Part No. B-59000A Pro Level Oil Gauge



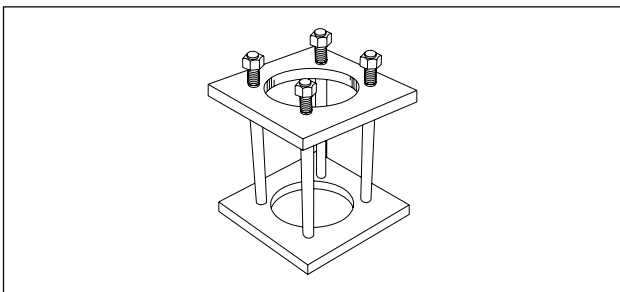
Part No. HD-33413-A Carburetor Idle Adjustment Tool



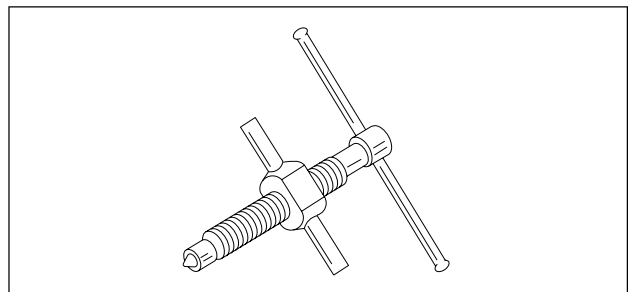
Part No. HD-25070 Robinair Heat Gun



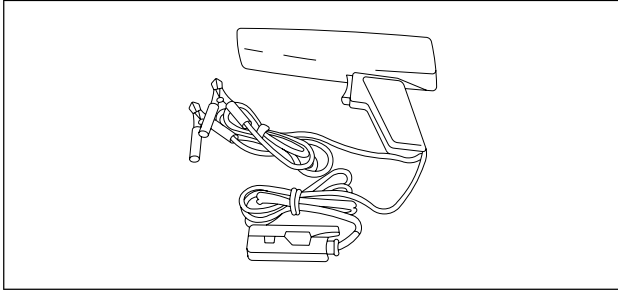
Part No. HD-33416 Universal Driver Handle



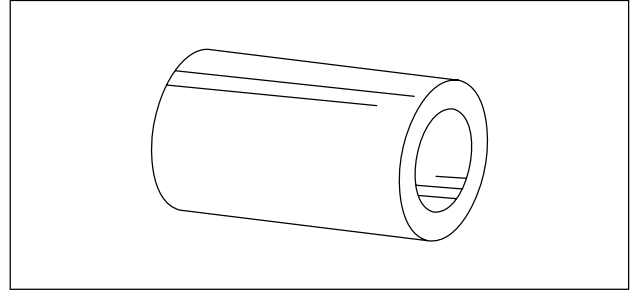
Part No. HD-33446A Cylinder Torque Plates and Torque Plate Bolts Part No. HD-33446-86.



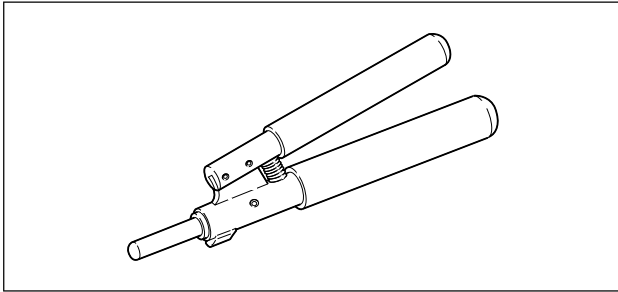
Part No. HD-33418 Universal Puller Forcing Screw



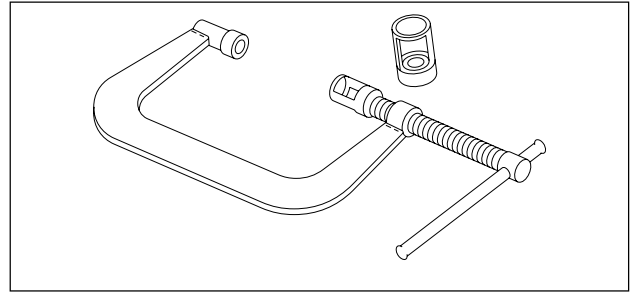
Part No. HD-33813 Inductive Timing Light



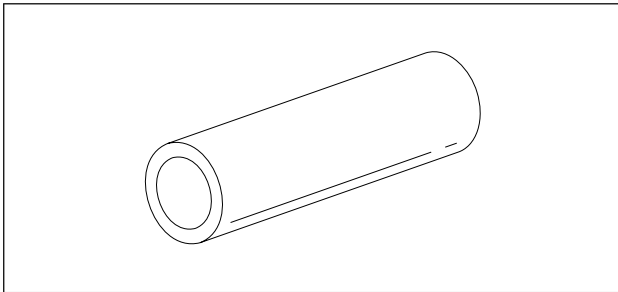
Part No. HD-34731 Shoulderless Valve Guide Installation Tool



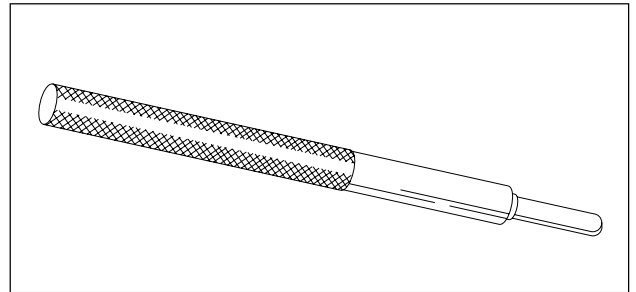
Part No. HD-34623B Piston Pin Retaining Ring Installer/Remover



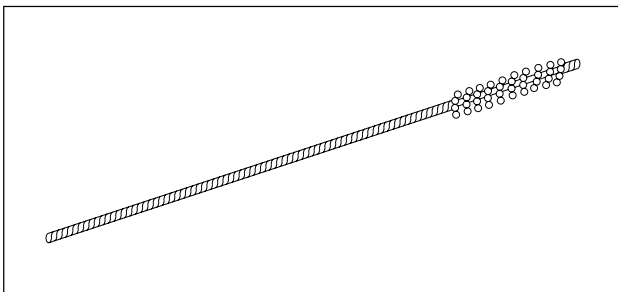
Part No. HD-34736B Valve Spring Compressor



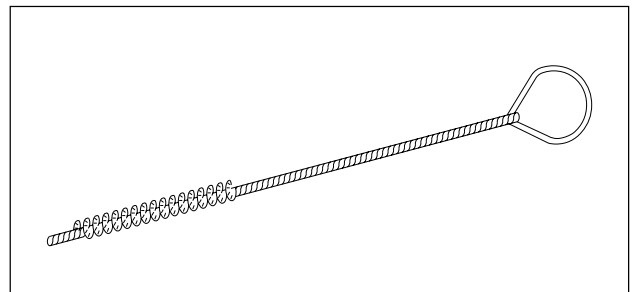
Part No. HD-34643A Shoulderless Valve Guide Seal Installer



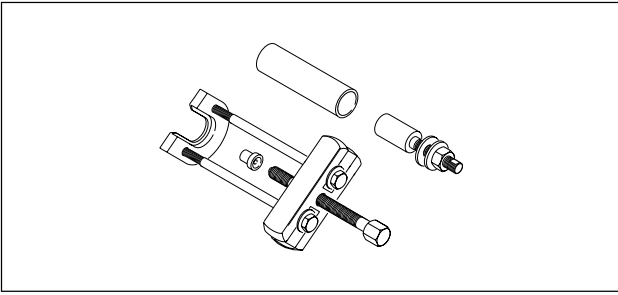
Part No. HD-34740 Driver Handle and Remover. Use with Part No. HD-34643A and art No. HD-34731.



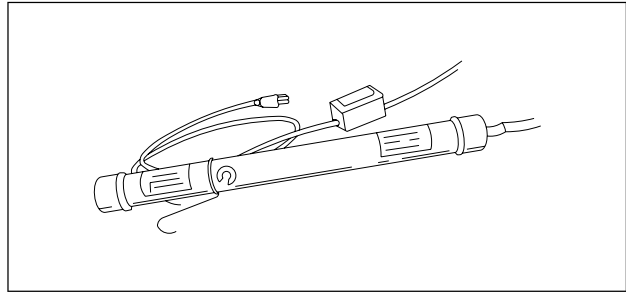
Part No. HD-34723 Valve Guide Hone (8 mm)



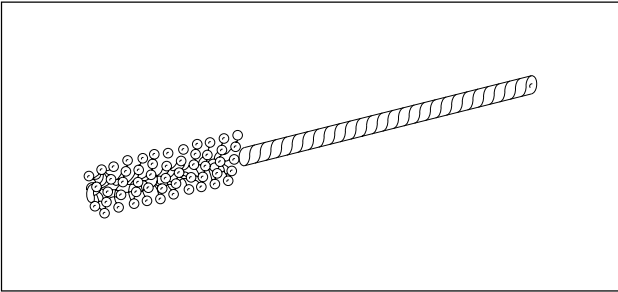
Part No. HD-34751 Nylon Valve Guide Brush



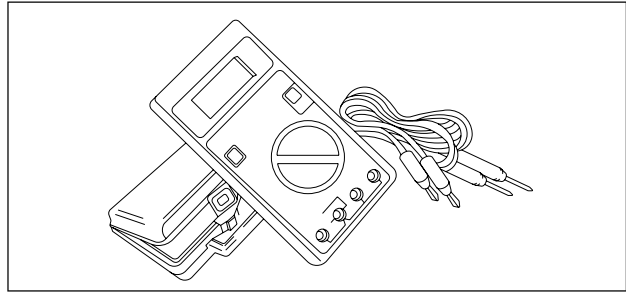
Part No. HD-34902-B Primary Bearing Race Remover/Installer



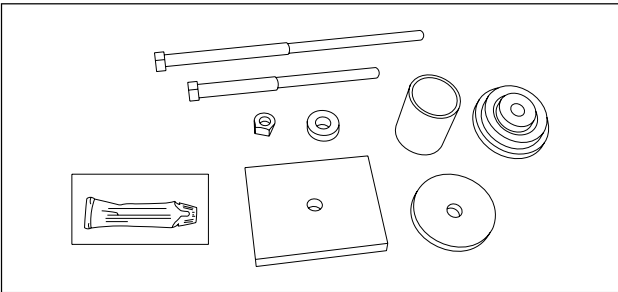
Part No. HD-35457 Black Light Leak Detector



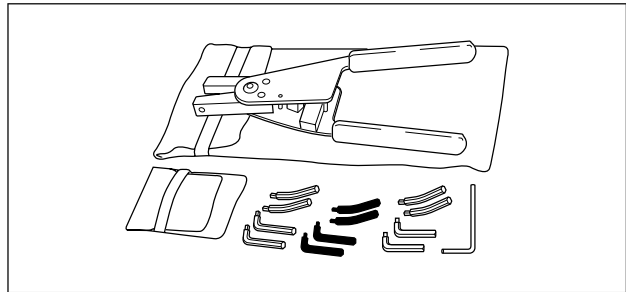
Part No. HD-35102 Wrist Pin Bushing Hone (20 mm)



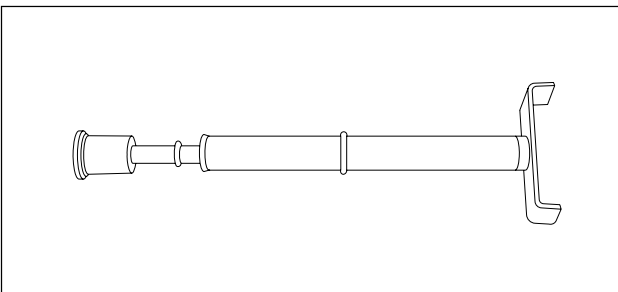
Part No. HD-35500A Digital Multi-Meter (FLUKE 23)



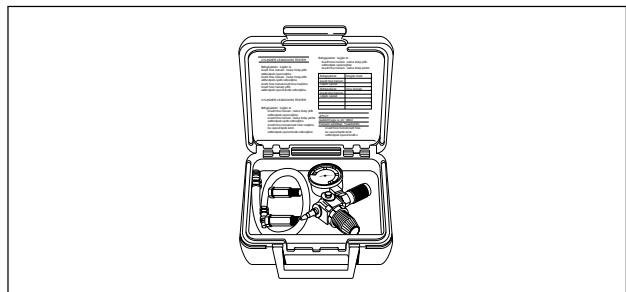
Part No. HD-35316-A Main Drive Gear Remover/Installer and Main Drive Gear Bearing Installer.



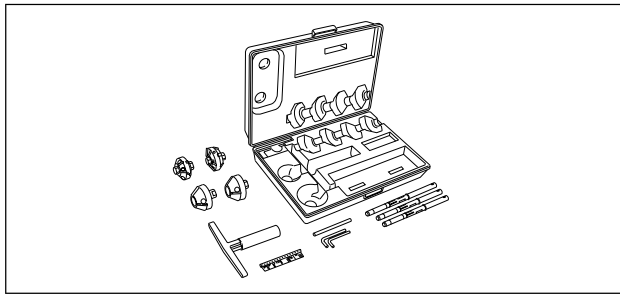
Part No. HD-35518 Internal/External Retaining Ring Pliers



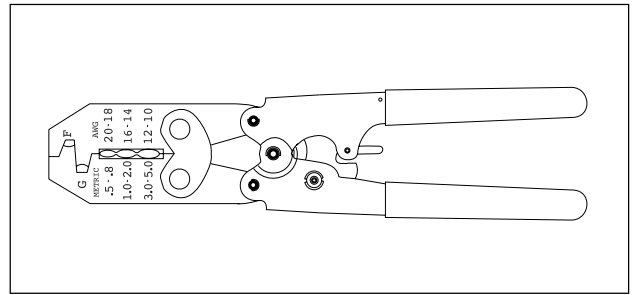
Part No. HD-35381 Belt Tension Gauge



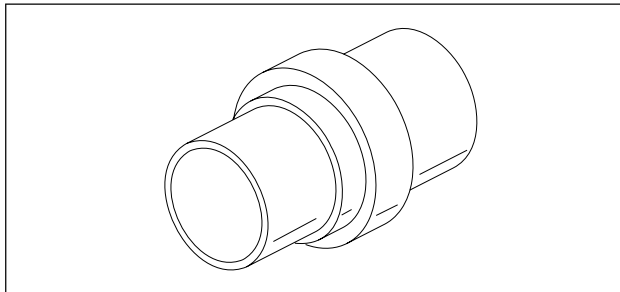
Part No. HD-35667A Cylinder Leakdown Tester



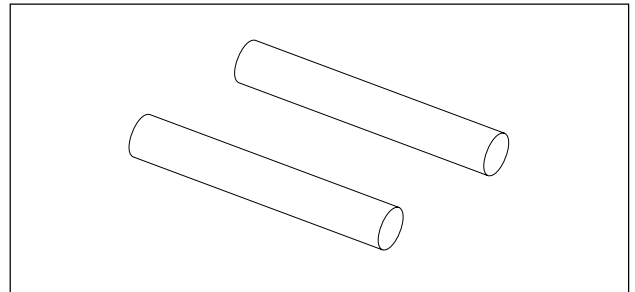
Part No. HD-35758 Neway Valve Seat Cutter Set



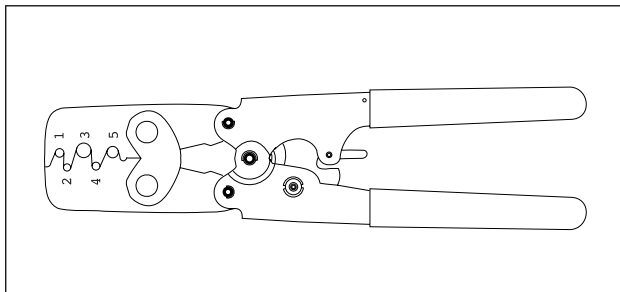
Part No. HD-38125-8 Packard Terminal Crimp Tool



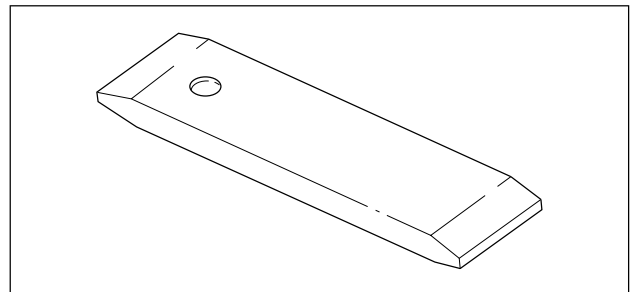
Part No. HD-37842A Inner/Outer Main Drive Gear Needle Bearing Installer



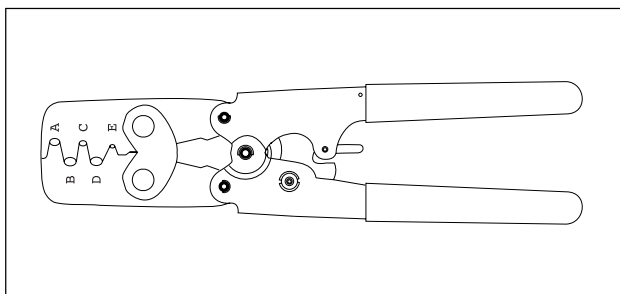
Part No. HD-38361 Cam Gear Gauge Pin Set (0.108 in. (2.74 mm) Diameter)



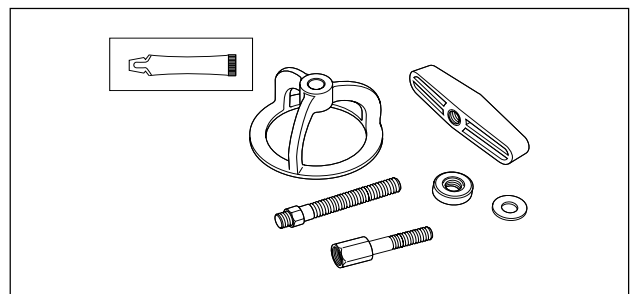
Part No. HD-38125-6 Packard Terminal Crimp Tool (Sealed and non-sealed connectors)



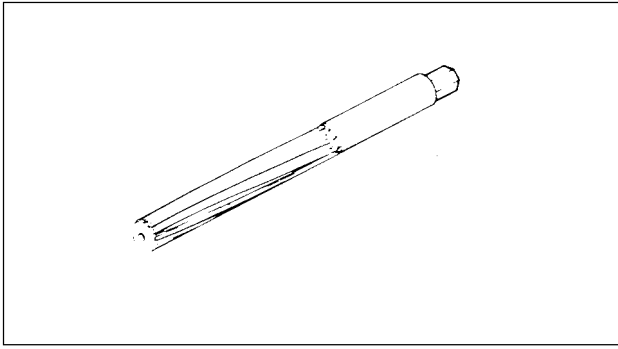
Part No. HD-38362 Sprocket Locking Link



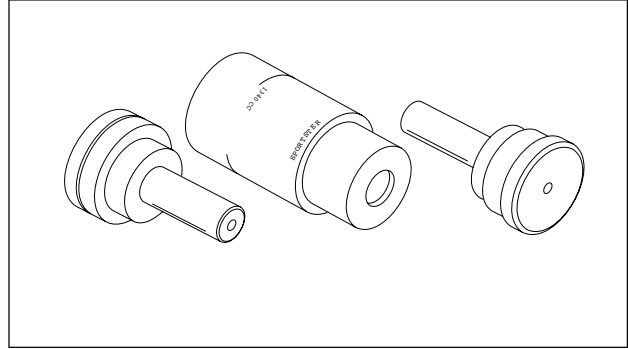
Part No. HD-38125-7 Packard Terminal Crimp Tool (Sealed connectors)



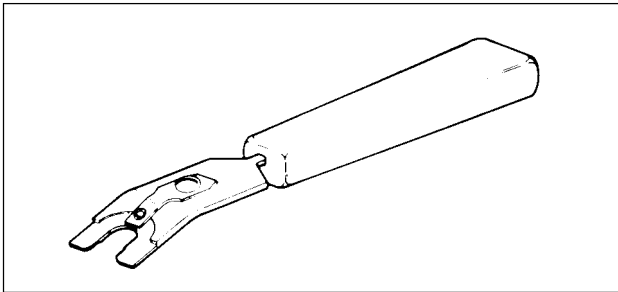
Part No. HD-38515-A Clutch Spring Compressing Tool and Part No. HD-38515-91 Forcing Screw.



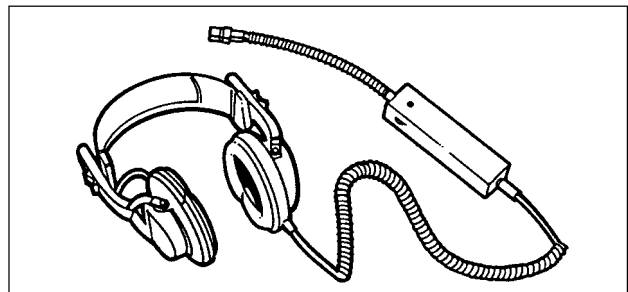
**Part No. HD-38871- 2 Reamer. Use with Part No. B-43988
Camshaft Bushing Reamer Fixture**



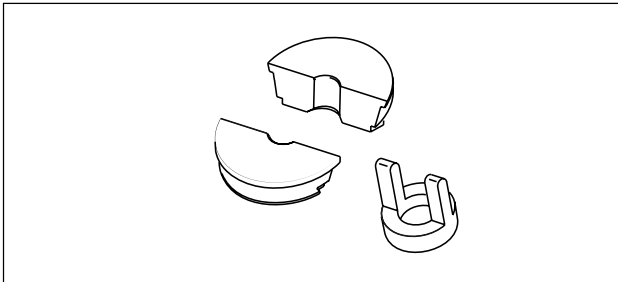
**Part No. HD-39458 Sprocket Shaft Bearing Outer
Race Installer**



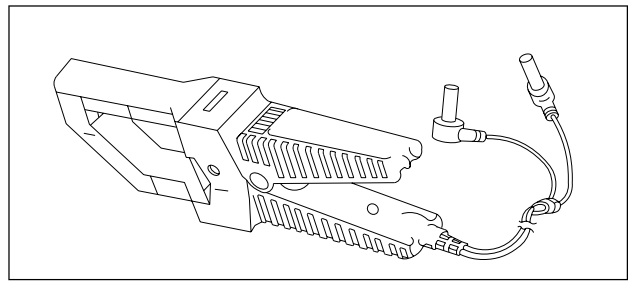
Part No. HD-39151 Shift Drum Retaining Ring Installer



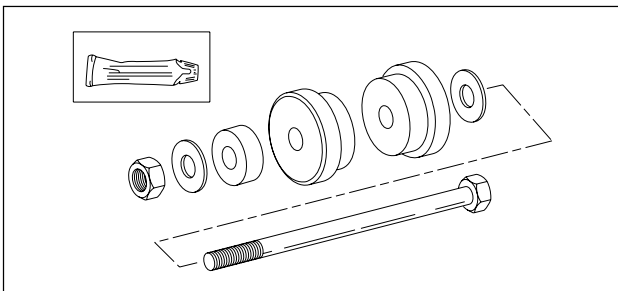
Part No. HD-39565 Engine Sound Probe



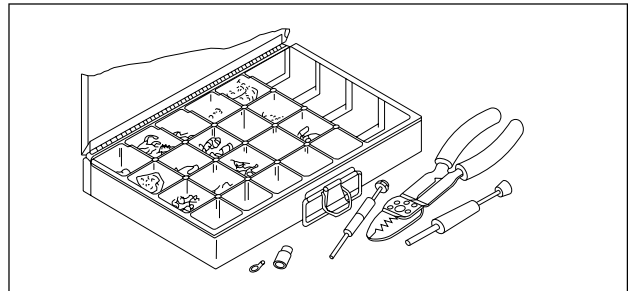
**Part No. HD-39301-A Steering Head Bearing
Race Remover**



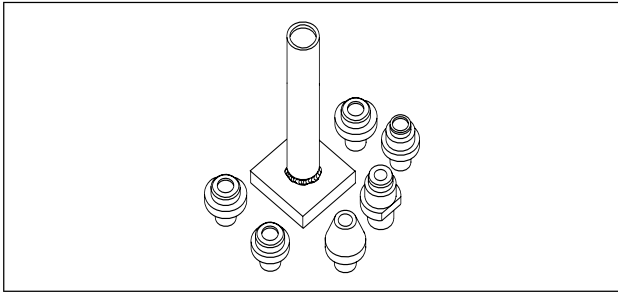
**Part No. HD-39617 Inductive Amp Probe.
Use with Part No. HD-35500A.**



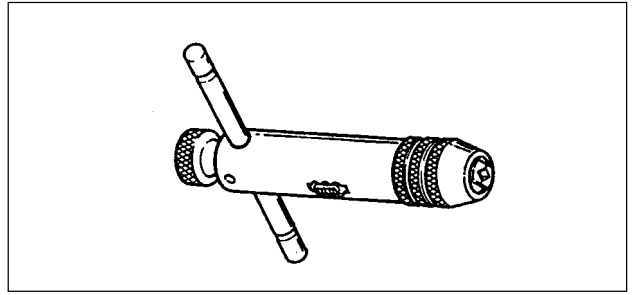
**Part No. HD-39302 Steering Head Bearing
Race Installer**



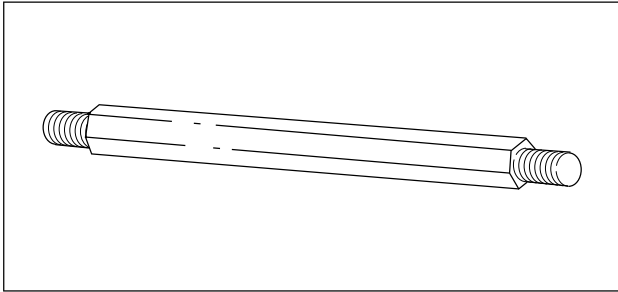
Part No. HD-39621 Electrical Terminal Repair Kit



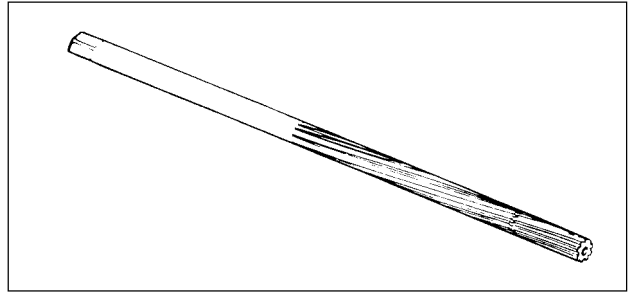
Part No. HD-39782 Cylinder Head Support



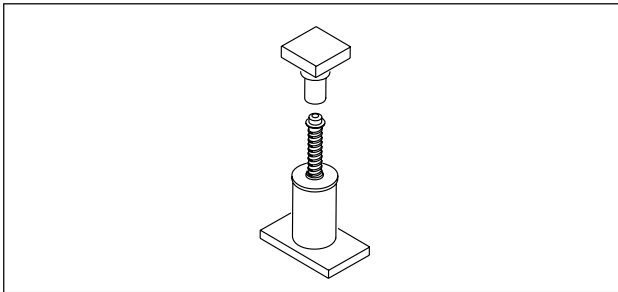
**Part No. HD-39847 Universal Ratcheting Tap/
Reamer Handle**



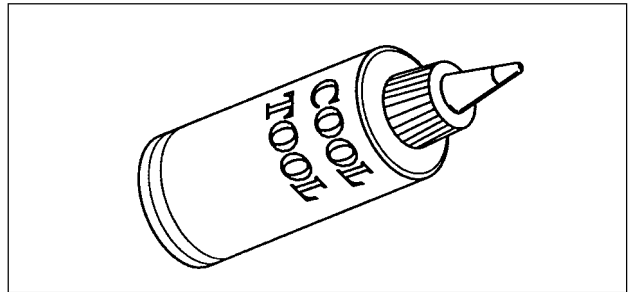
Part No. HD-39786 Cylinder Head Holding Fixture



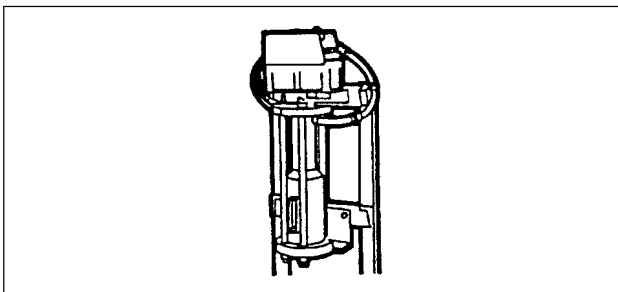
**Part No. HD-39932 (Steel) or HD-39932-CAR (Carbide)
Intake and Exhaust Valve Guide Reamer.**



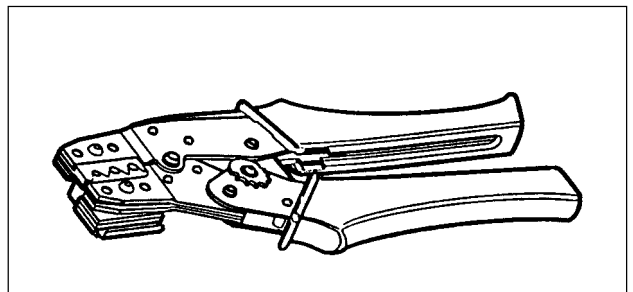
Part No. HD-39800 Oil Filter Crusher, Small



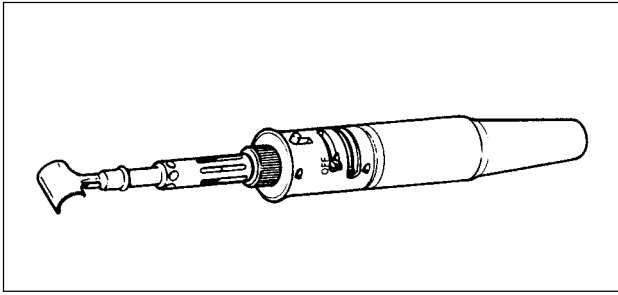
Part No. HD-39964 Reamer Lubricant (Cool Tool)



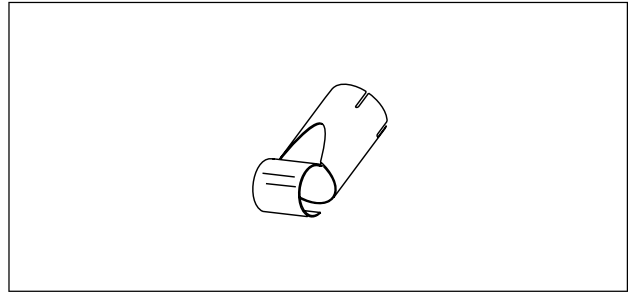
Part No. HD-39823 Oil Filter Crusher, Large



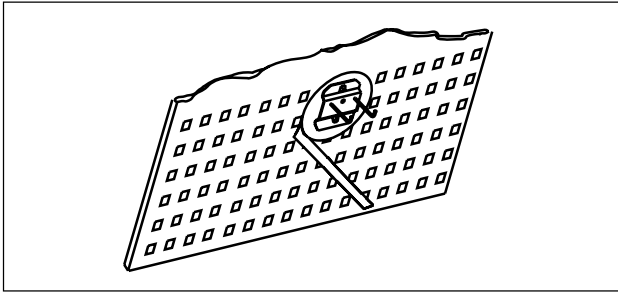
Part No. HD-39965 Deutsch Terminal Crimp Tool



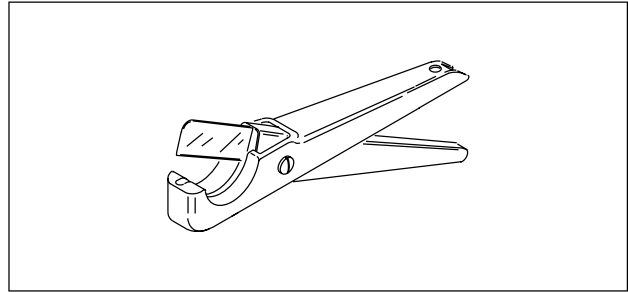
Part No. HD-39969 Ultra-Torch UT-100



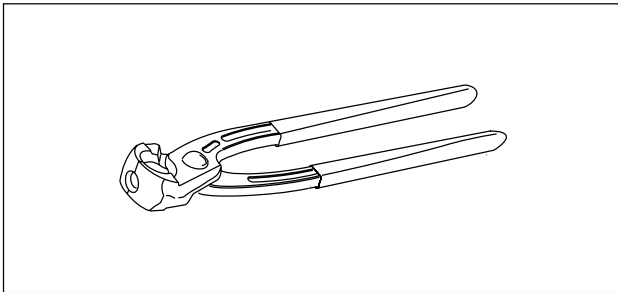
**Part No. HD-41183 Heat Shield Attachment.
Use with Part No. HD-25070.**



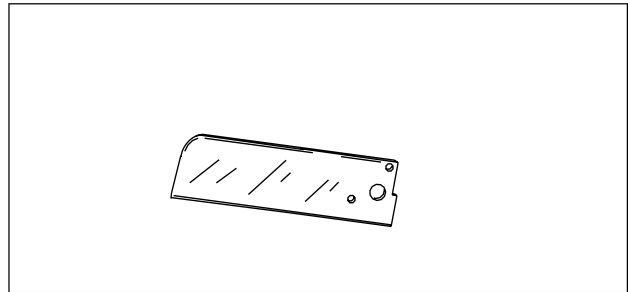
Part No. BU-44473 Tool Organizational System



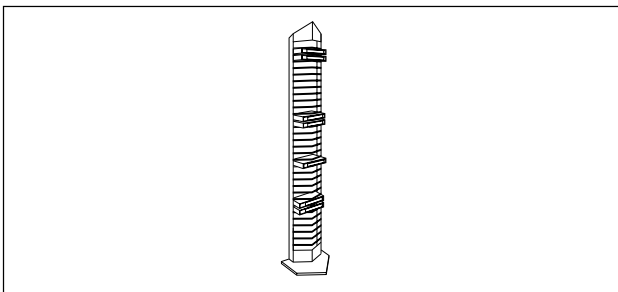
Part No. HD-41185 Hose Cutting Tool



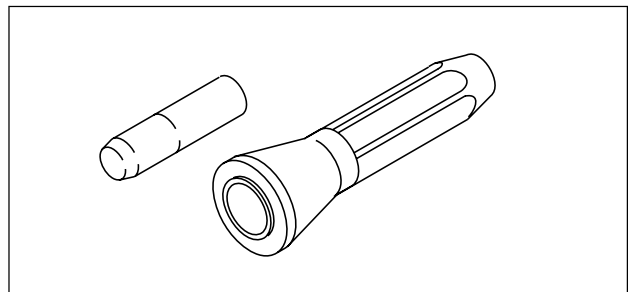
Part No. HD-41137 Hose Clamp Pliers



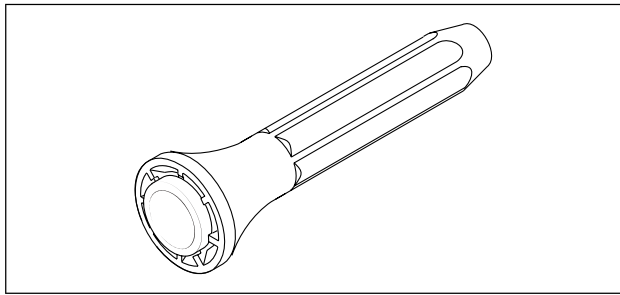
Part No. HD-41185-1 Oil Hose Cutter-Replacement Blade



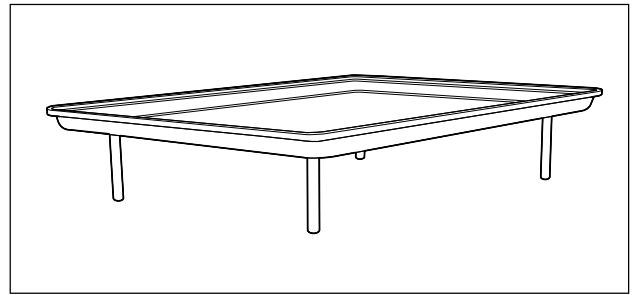
Part No. HD-41155 VHS Video Shelf



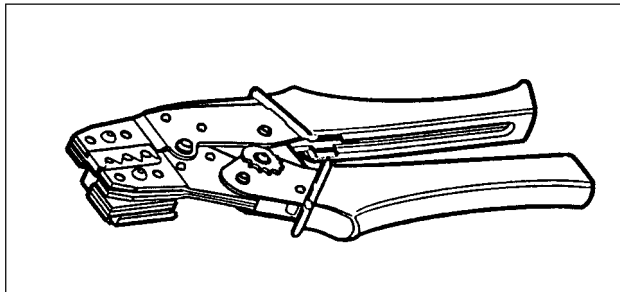
Part No. HD-41405 Main Drive Gear Seal Installer



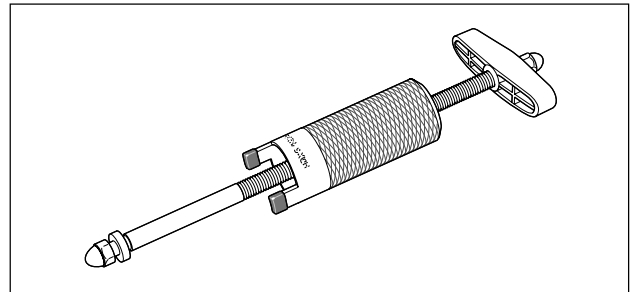
Part No. HD-41496 Main Drive Gear Seal Installer



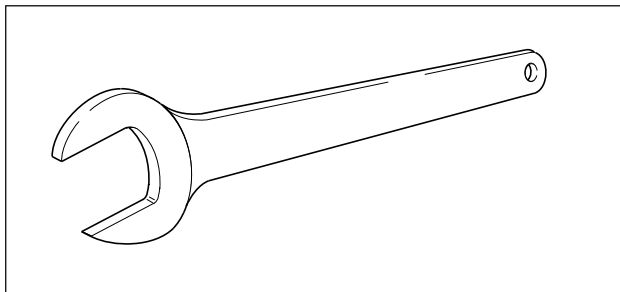
Part No. HD-42310-150 Drip Tray.
Use with Part No. HD-42310.



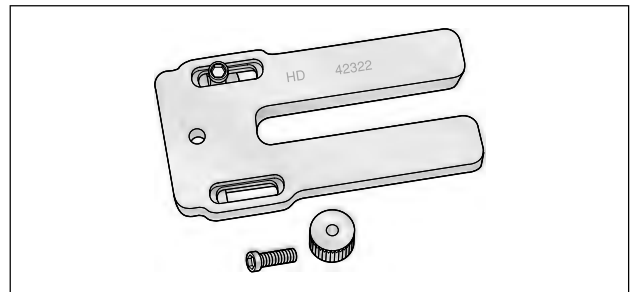
Part No. HD-41609 Amp Terminal Crimp Tool



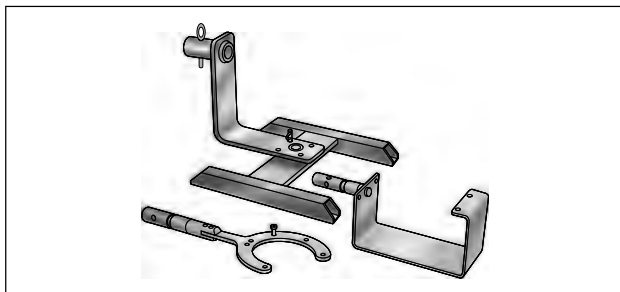
Part No. HD-42320 Piston Pin Remover/Installer



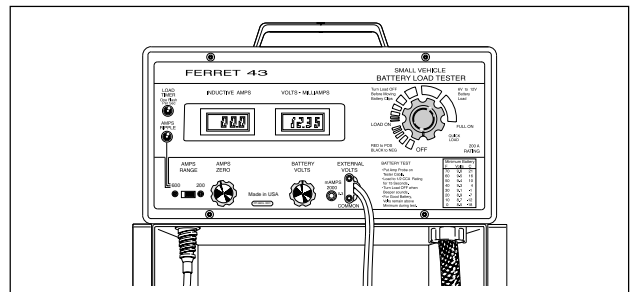
Part No. HD-41675 Oil Pressure Sending Unit Wrench



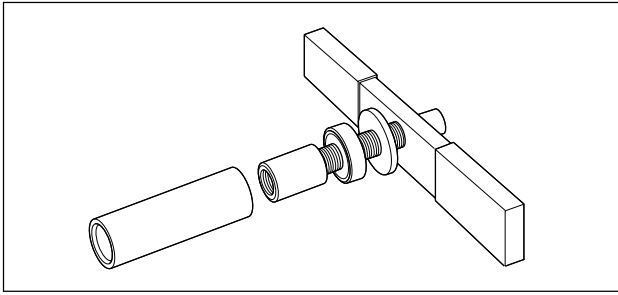
Part No. HD-42322 Piston Support Plate



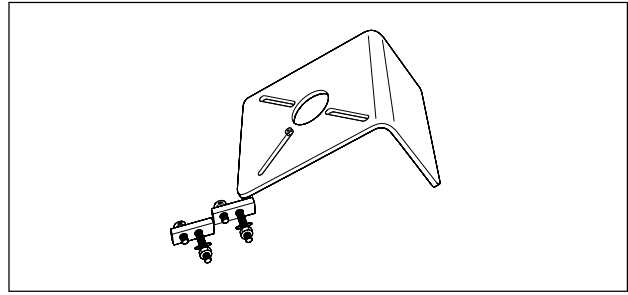
Part No. HD-42310 Engine/Transmission Stand



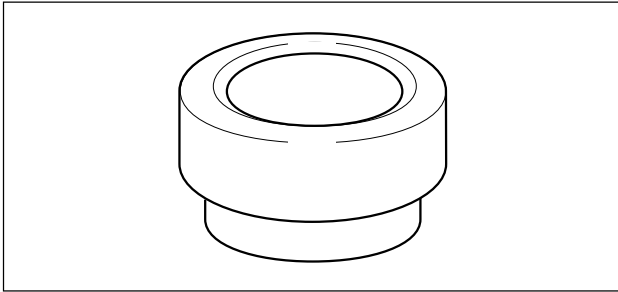
Part No. HD-42376 Battery/Charging System
Load Tester



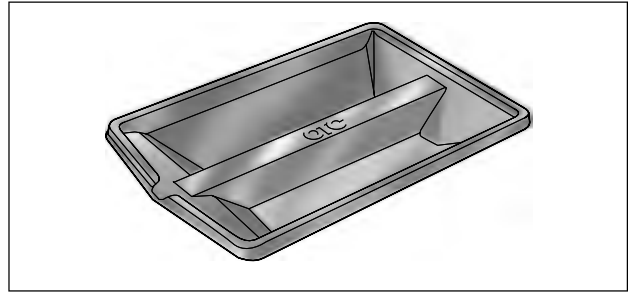
Part No. HD-42579 Sprocket Bearing/Seal Installer



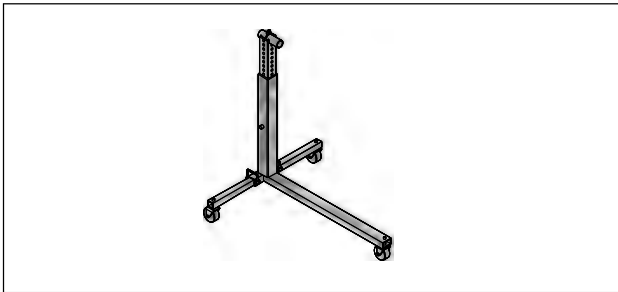
Part No. HD-44358 Flywheel Support Fixture



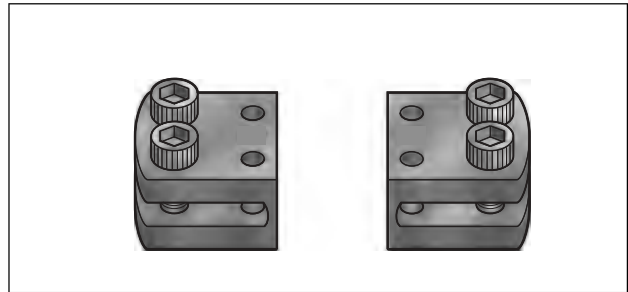
Part No. HD-42774 Sprocket Shaft Seal Installer



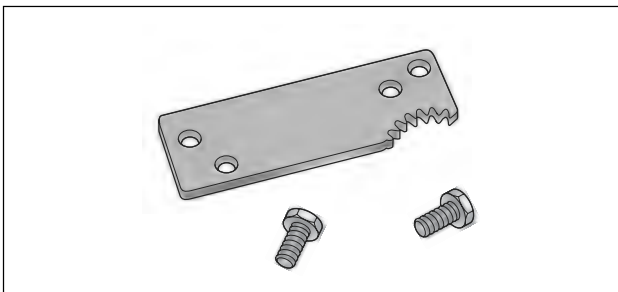
Part No. HD-43682-10 Drip pan.
Use with Part No. HD-43682 or Part No. HD-43646.



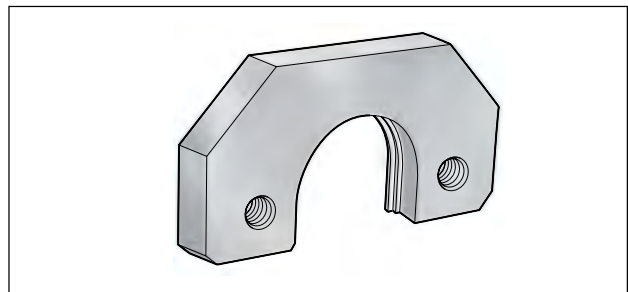
Part No. HD-43646 Engine Stand



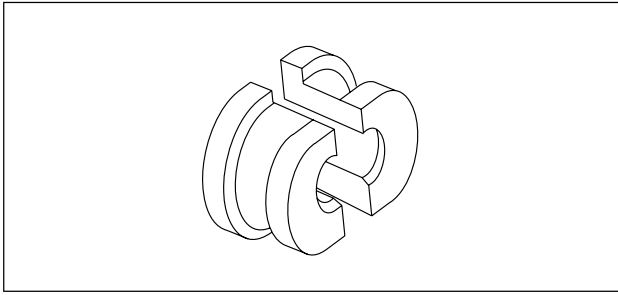
Part No. HD-44069 Timkin Snap ring remover and installer. Use with Part No. HD-44404.



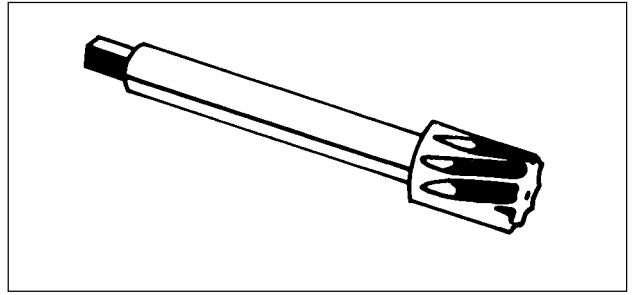
Part No. HD-43984 Crankshaft Locking Tool



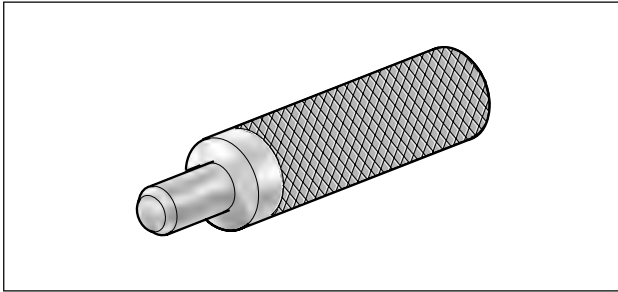
Part No. HD-44404 Timkin Bearing Remover. Use with Part No. HD-44069.



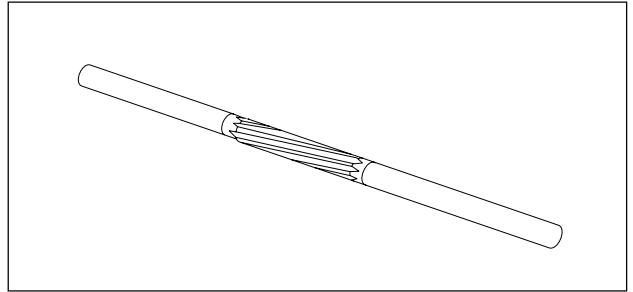
Part No. HD-94547-101 Crankshaft Bearing Outer Race Remover. Use with Part No. HD-94547-102.



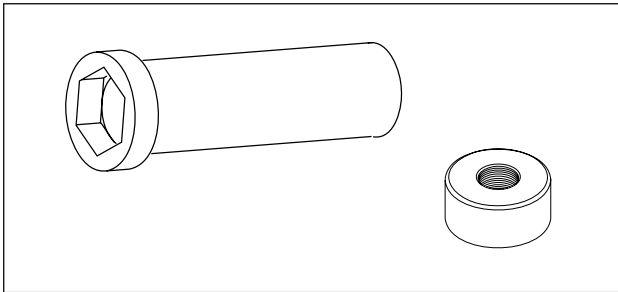
Part No. HD-94803-67 Intake Camshaft Bushing Reamer



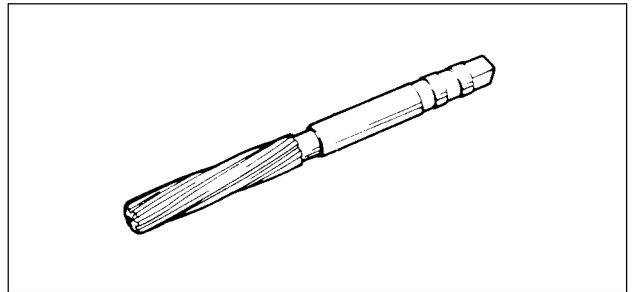
Part No. HD-94547-102 Drive Handle. Use with Part No. HD-94547-101.



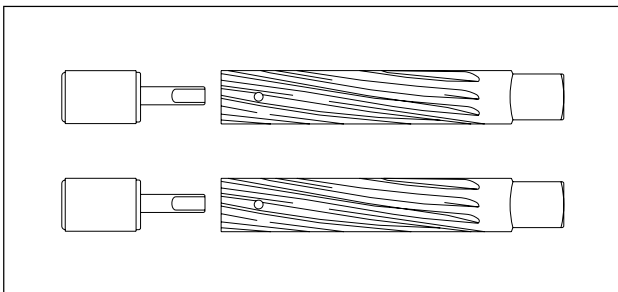
Part No. HD-94804-57 Rocker Arm Bushing Reamer



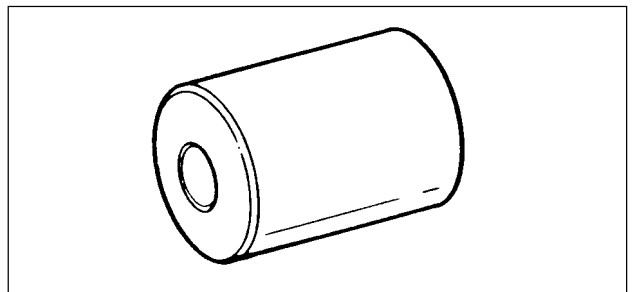
**Part No. HD-94660-37B Mainshaft Locknut Wrench
Use with Part No. B-43982.**



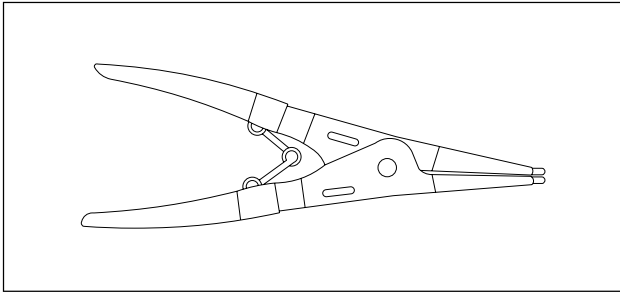
**Part No. HD-94812-1 Pinion Shaft Bushing Reamer.
Use with Part No. HD-94812-87.**



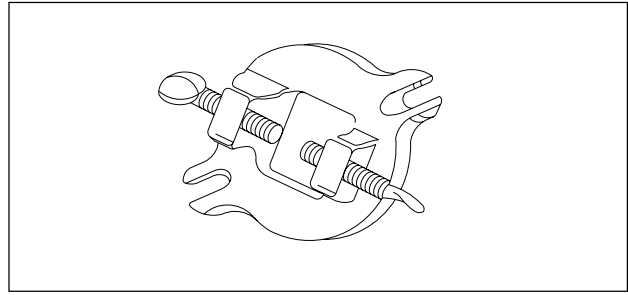
Part No. HD-94800-26A Connecting Rod Bushing Reamers and Pilots



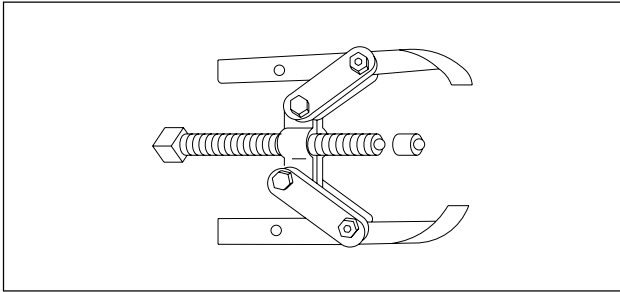
**Part No. HD-94812-87 Pinion Shaft Reamer Pilot.
Use with Part No. HD-94812-1.**



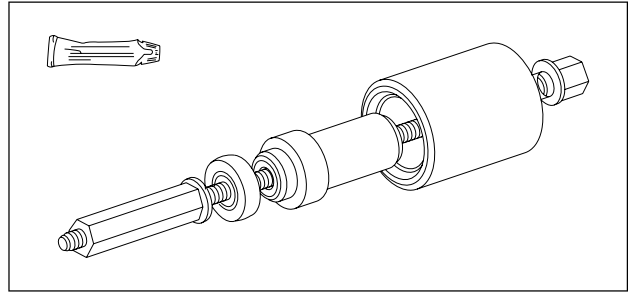
Part No. HD-95017-61 Large External Retaining Ring Pliers



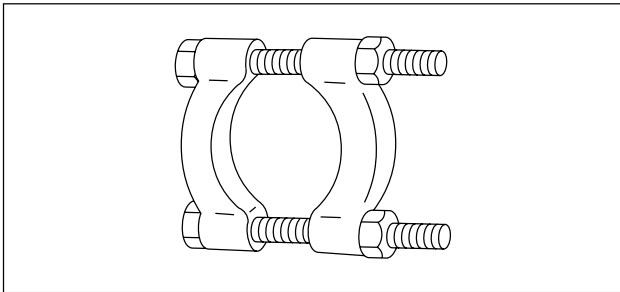
Part No. HD-95952-33B Connecting Rod Clamping Tool



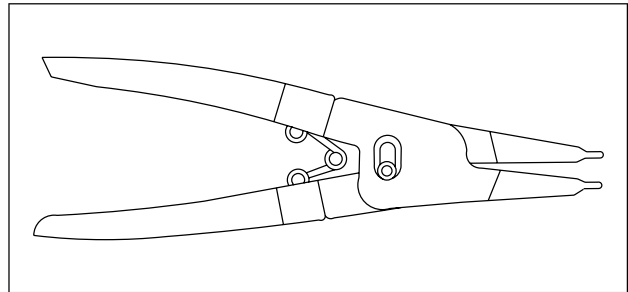
Part No. HD-95635-46 All-Purpose Claw Puller



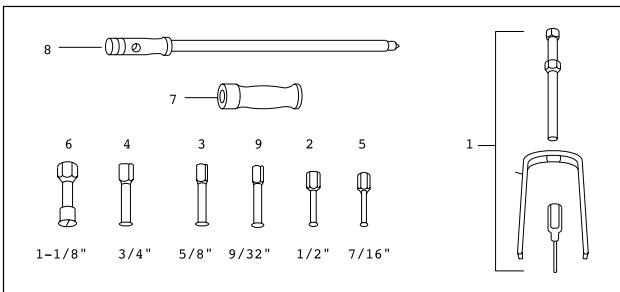
Part No. HD-95970-32D Piston Pin Bushing Tool



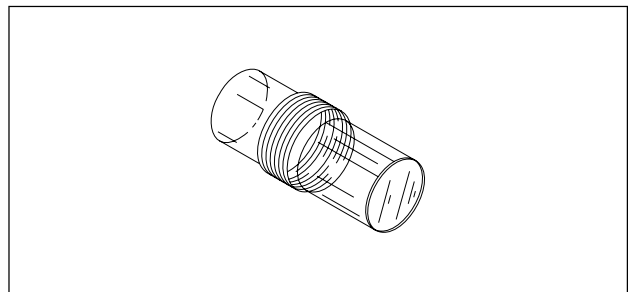
Part No. HD-95637-46A Wedge Attachment for Claw Puller. Use with Part No. HD-95635-46.



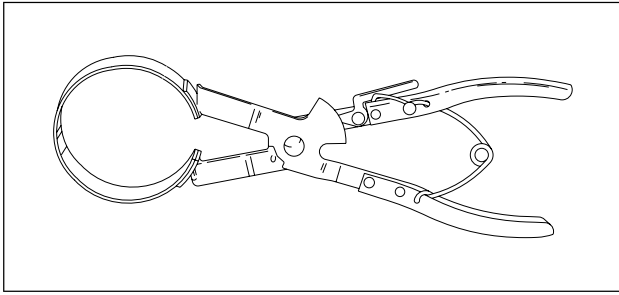
Part No. HD-96215-49 Small Internal Retaining Ring Pliers



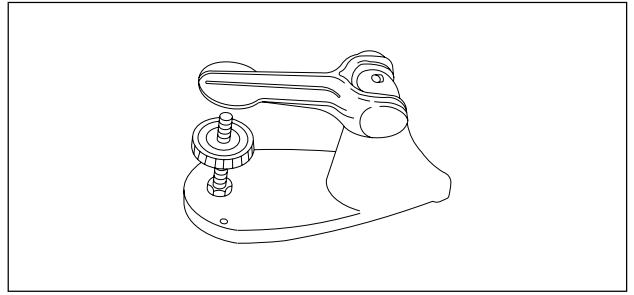
Part No. HD-95760-69A Bushing/Bearing Puller Tool Set includes items 1-7. Items 8 (HD-95769-69), 9 (HD-95770-69) and 10 (HD-95771-69) are optional.



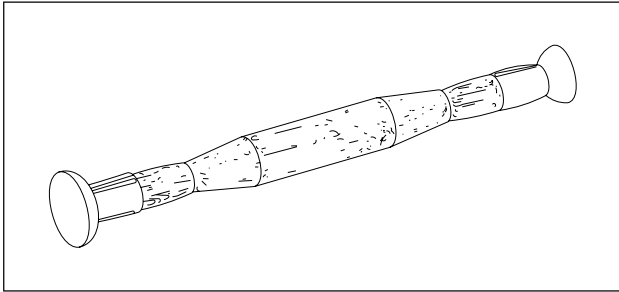
Part No. HD-96295-65D Timing Mark View Plug. Use with Part No. HD-33813.



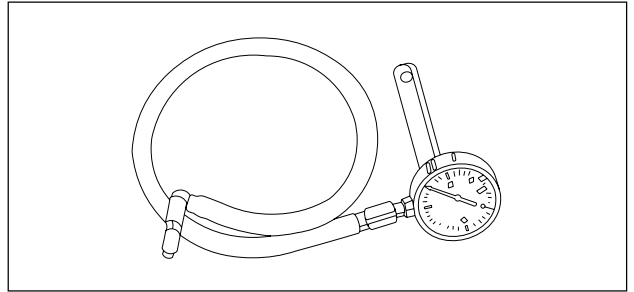
Part No. HD-96333-51C Piston Ring Compressor



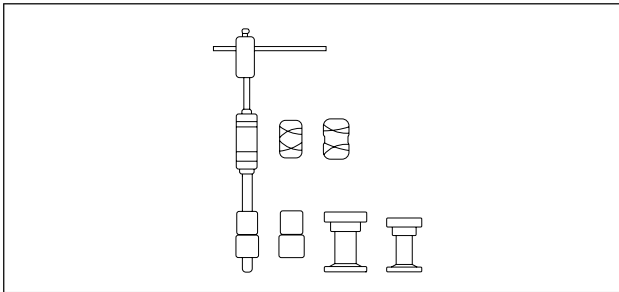
Part No. HD-96796-47 Valve Spring Tester



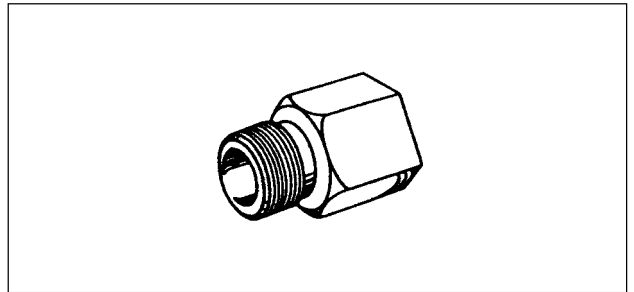
Part No. HD-96550-36A Valve Lapping Tool



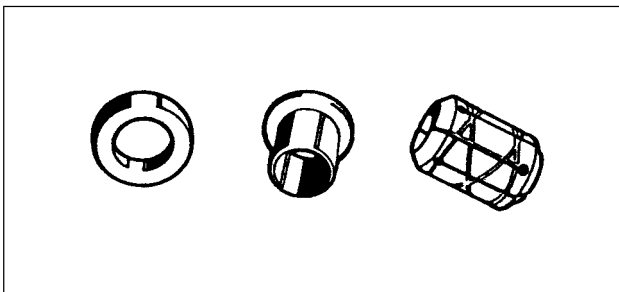
Part No. HD-96921-52B Oil Pressure Gauge



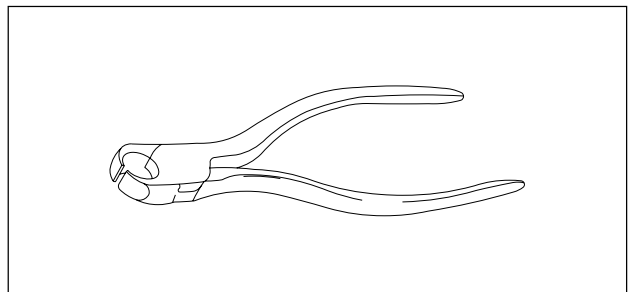
Part No. HD-96710-40B Crankcase Main Bearing Lapping Tool



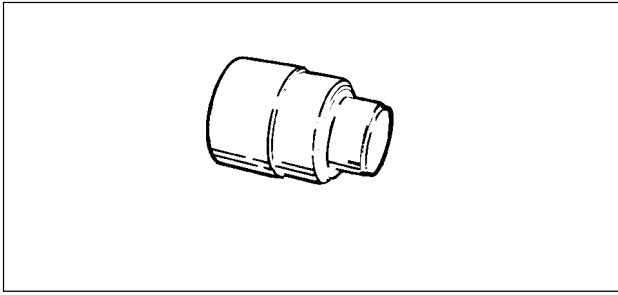
**Part No. HD-96921-58 Oil Pressure Gauge Adapter.
Use with Part No. HD-96921-52B.**



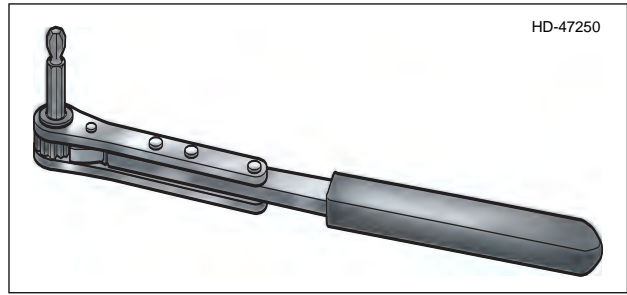
Part No. HD-96718-87 Pinion Bearing Outer Race Lapping Kit



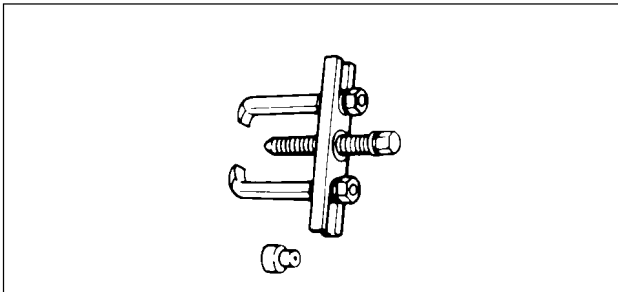
Part No. HD-97087-65B Hose Clamp Pliers



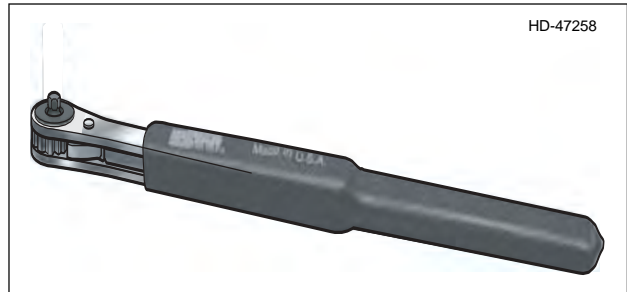
Part No. HD-97273-60 Camshaft Bushing Installer



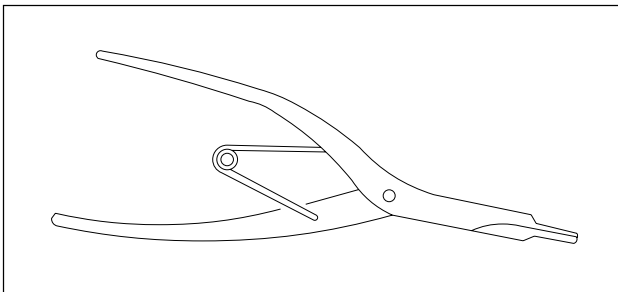
Part No. HD-47250 Intake Manifold Wrench



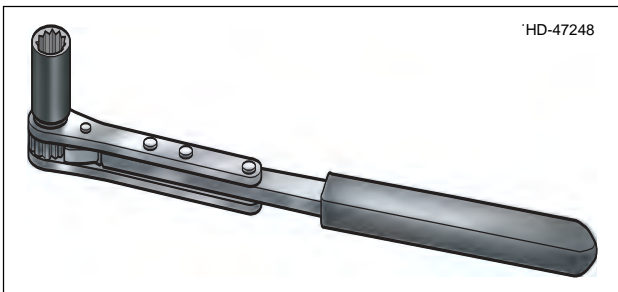
Part No. HD-97292-61 Two Claw Puller



Part No. HD-47258 Rocker Cover Wrench



Part No. J-5586 Transmission Shaft Retaining Ring Pliers



Part No. HD-47248 Rocker Housing Wrench

CONNECTORS

Function/Location

Refer to [Table B-1](#). On the motorcycle, a connector can be identified by its function and location.

Place and Color

The place (number of wire cavities of a connector housing) and color of the connector can also aid identification.

Connector Number

On wiring diagrams and in service/repair instructions, connectors are identified by a number in brackets.

Repair Instructions

Refer to [Table B-1](#). The repair instructions in this Service Manual are by connector type.

Table B-1. Electrical Connectors: 2007 Blast P3 Model

COMPONENT(S)	LOCATION	PLACE	NO.	REPAIR INSTRUCTIONS
Bank angle sensor	Under Seat to right of battery	3	[134]	Packard
Clutch switch	At left handlebar	2	[95]	B.2 AMP MULTILOCK
Front brake switch	At right handlebar switch	2	[170]	blade-type
Flasher relay	Under seat, to right of battery	3-blade	[30]	relay
Fuse block	Under seat on right side	9-slot	[61]	fuse block
Headlamp	Behind windscreen/headlamp	4	[38]	B.2 AMP MULTILOCK
Horn	At horn, behind front fork	2	[122]	blade-type
Ignition coil	Under frame backbone at coil	3	[83]	B.2 AMP MULTILOCK
Ignition/headlamp key switch	Behind windscreen	4	[33]	B.9 DEUTSCH and B.4 DEUTSCH STANDARD TERMINAL
Indicators/speedometer	Behind windscreen	12	[20]	B.9 DEUTSCH and B.4 DEUTSCH STANDARD TERMINAL
Integrated ignition module sensor	Left side of frame backbone on T-stud	6	[10]	B.9 DEUTSCH and B.4 DEUTSCH STANDARD TERMINAL
Left handlebar switch housing-turn signals, lights	Behind windscreen	10	[24]	B.2 AMP MULTILOCK
Neutral switch	Behind sprocket cover, right side	Post	[131]	post
Neutral switch to main harness	Above sprocket cover, right side	1	[172]	bullet
Oil pressure switch	Above oil filter, right lower side of crankcase	Post	[120]	post
Rear stoplight switch	At switch, under frame by shock absorber	2	[121]	blade-type
Right handlebar switch housing-ignition power, module and starter	Behind windscreen	4	[22]	B.2 AMP MULTILOCK
Side stand switch	On top of swingarm, cable tied to rear brake line	2	[60]	B.2 AMP MULTILOCK

Table B-1. Electrical Connectors: 2007 Blast P3 Model

COMPONENT(S)	LOCATION	PLACE	NO.	REPAIR INSTRUCTIONS
Speed sensor	Under seat, to right of shock	3	[65]	B.9 DEUTSCH and B.4 DEUTSCH STANDARD TERMINAL
Speedometer/indicators	On back of speedometer	12	[39]	Packard
Starter	Under starter solenoid	1	[128]	blade-type
System relay	Under seat, to left of battery	4-blade	[171]	relay
Tail lamp/rear directionals	Under Seat	6	[7]	B.2 AMP MULTILOCK
Throttle position sensor and auto-enrichener	Under frame backbone, right side	6	[88]	B.9 DEUTSCH and B.4 DEUTSCH STANDARD TERMINAL
Voltage regulator	Above swingarm, left side	2	[46]	barrel

GENERAL

PART NO.	SPECIALTY TOOL
HD-39621-A	Terminal repair kits
HD-41609	Amp Multi-lock crimper
HD-39621-28	Pin terminal tool
HD-39621-27	Socket terminal tool

Amp Multilock connectors are found in 3-place, 6-place and 10-place versions though not all terminal cavities may be used. Amp Multilock connectors are found between wire harnesses and component wiring and may be either floating or anchored to the frame with attachment clips.

See [Figure B-1](#). Attachment clips (1) on the pin housings are fitted to T-studs on the motorcycle frame. The T-studs identify OE connector locations. To maintain serviceability, always return connectors to OE locations after service.

NOTE

A *TERMINAL REPAIR KIT (HD-39621-A)* contains a variety of replacement Amp terminals and the pin and socket tools. For terminal crimping use the *PACKARD TERMINAL CRIMPER (HD-38125-7)*.

PIN AND SOCKET HOUSINGS

Separate Housings

1. If necessary, slide connector with attachment clip rearward to release it from the T-stud.
2. See [Figure B-1](#). Depress the release button (2) on the socket terminal side of the connector and pull the socket housing (plug) (3) out of the pin housing (receptacle) (4).

Mate Housings

1. Hold the housings to match wire color to wire color.
2. Insert the socket housing into the pin housing until it snaps in place.
3. If OE location is a T-stud, fit large opening end of attachment clip over T-stud and slide connector forward to engage T-stud to small end of opening.

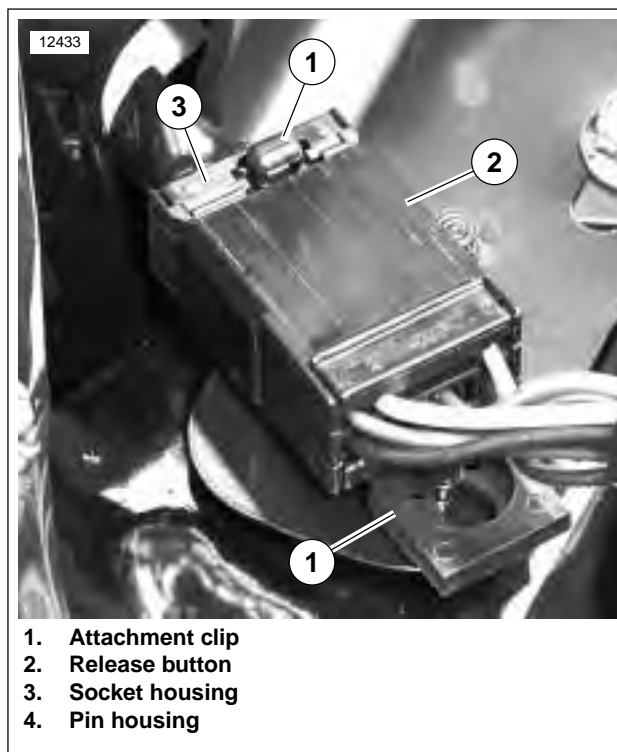


Figure B-1. Amp Multilock Connector]

WIRE TERMINALS

Remove Terminals from Housing

1. See Figure B-2. Bend back the latch (1) to free one end of secondary lock (2) then repeat on the opposite end. Hinge the secondary lock outward.
2. Look in the terminal side of the connector (opposite the secondary lock) and note the cavity next to each terminal.
3. Insert the terminal tool into the cavity until it stops.

Socket: SOCKET TERMINAL TOOL (HD-39621-27)

Pin: PIN TERMINAL TOOL (HD-39621-28)

NOTE

If socket/pin terminal tool is not available, a push pin/safety pin or a Snap-On (Part No. TT600-3) pick may be used.

4. Press the tang in the housing to release the terminal.

Socket: Lift the socket tang (8) up.

Pin: Press the pin tang (7) down.

NOTE

A "click" is heard if the tang is released.

5. Gently tug on wire to pull wire and terminal from cavity.

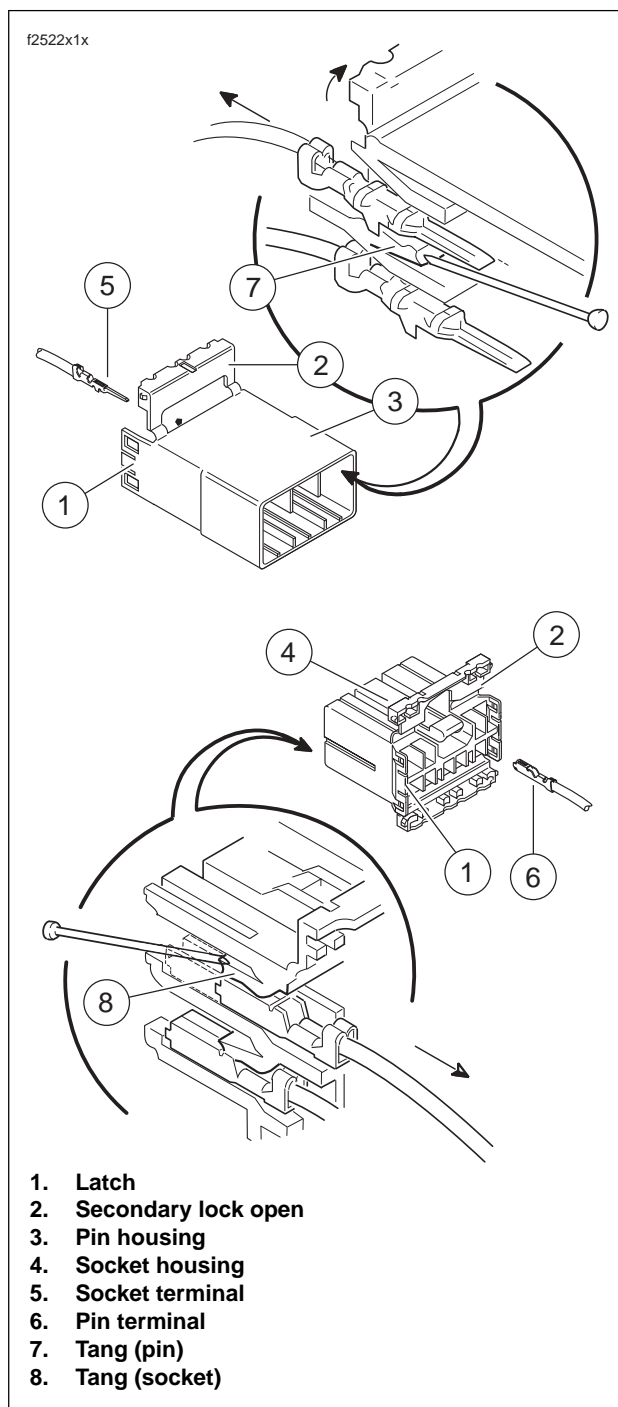


Figure B-2. Socket and Pin Housings

Insert Terminals into Housings

NOTE

See [Figure B-3](#). Cavity numbers are stamped into the secondary locks of both the socket and pin housings. Match the wire color to the cavity number found on the wiring diagram.

1. Hold the terminal so the catch faces the tang in the chamber. Insert the terminal into its numbered cavity until it snaps in place.

NOTES

- *Up and down can be determined by the position of the release button, the button is the top of the connector.*
 - *On the pin side of the connector, tangs are positioned at the bottom of each cavity, so the slot in the pin terminal (on the side opposite the crimp tails) must face downward.*
 - *On the socket side, tangs are at the top of each cavity, so the socket terminal slot (on the same side as the crimp tails) must face upward.*
2. Gently tug on wire end to verify that the terminal is locked in place.
 3. Rotate the hinged secondary lock inward until tabs fully engage latches on both sides of connector.

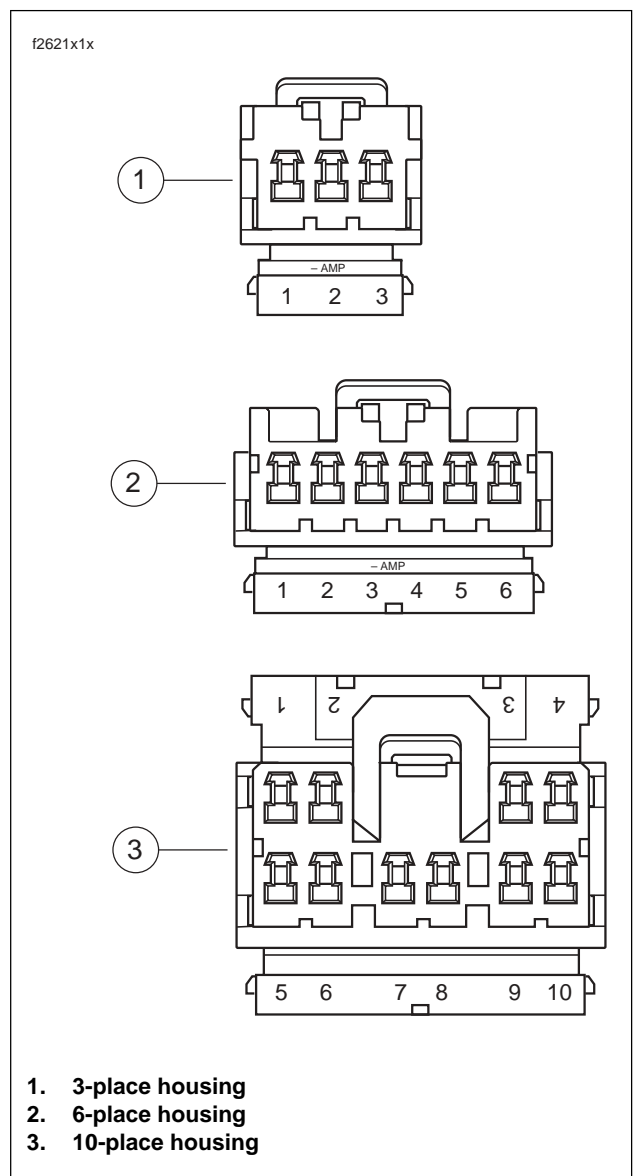


Figure B-3. Cavity Numbers on Secondary Locks (socket housings shown)

TERMINAL CRIMPS

Prepare Wire Leads

1. Strip wire lead removing 0.1562 in. (3/16") (4.0 mm) of insulation from the wire lead.
2. See [Figure B-4.](#) and [Figure B-5.](#) Select the pin/socket terminals from the parts catalog and identify the wire crimp tails (1) and the insulation crimp tails (2) and the groove for the crimp tool locking bar (3).
3. Identify the wire lead gauge and the corresponding crimper tool and nesting die.

Table 1-2. Crimp Tool Wire Gauge/Nest

Wire Gauge	Nest
20	Front
16	Middle
18	Rear

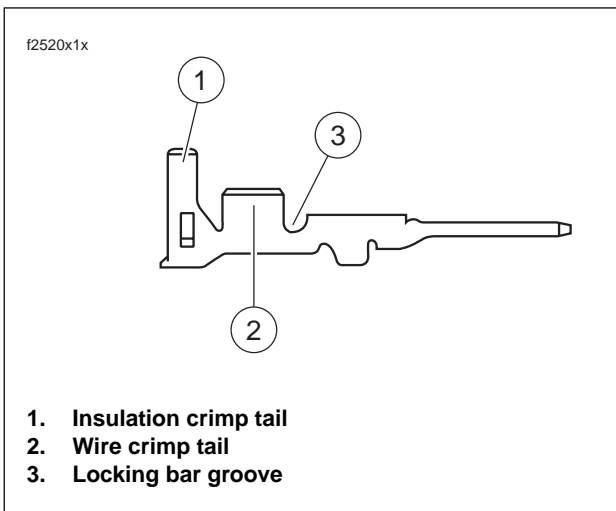


Figure B-4. Pin Terminal

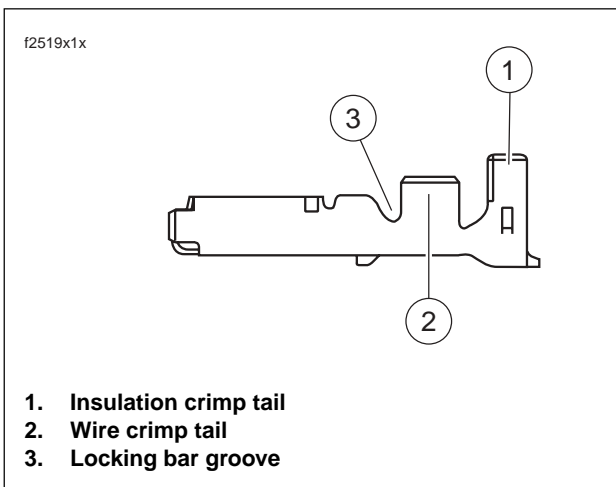


Figure B-5. Socket Terminal

Crimp Terminals to Leads

NOTE

Crimping with an Amp Multilock tool is a one step operation. One Squeeze crimps both the wire core and the insulation tails.

1. See [Figure B-6.](#) Squeeze the handles to cycle the AMP MULTI-LOCK CRIMPER (HD-41609) to the fully open position (1).
2. Raise locking bar by pushing up on bottom flange (2).

NOTE

See [Figure B-4.](#) and [Figure B-5.](#) Hold the terminal with the installation crimp tail (1) facing up. The tool will hold the terminal by the locking bar groove (3) and crimp the wire crimp tail (2) around the bare wire of the stripped lead and the insulation crimp tail around the insulation.

3. See [Figure B-6.](#) With the installation crimp tail facing upward, insert terminal (pin or socket) (3) through the locking bar, so that the closed side of the terminal rests on the nest of the crimp tool. Refer to [Table 1-2.](#)
4. Release locking bar to lock position of contact (4). When correctly positioned, the locking bar fits snugly in the space at the front of the core crimp tails.
5. Insert stripped end of lead (5) until ends make contact with locking bar.
6. Verify that wire is positioned (6) so that wire crimp tails squeeze bare wire strands, while insulation crimp tails fold over the wire lead insulation.
7. Squeeze handle of crimp tool until tightly closed (7). Tool automatically opens when the crimping sequence is complete.
8. Raise up locking bar (8) and remove crimped terminal.

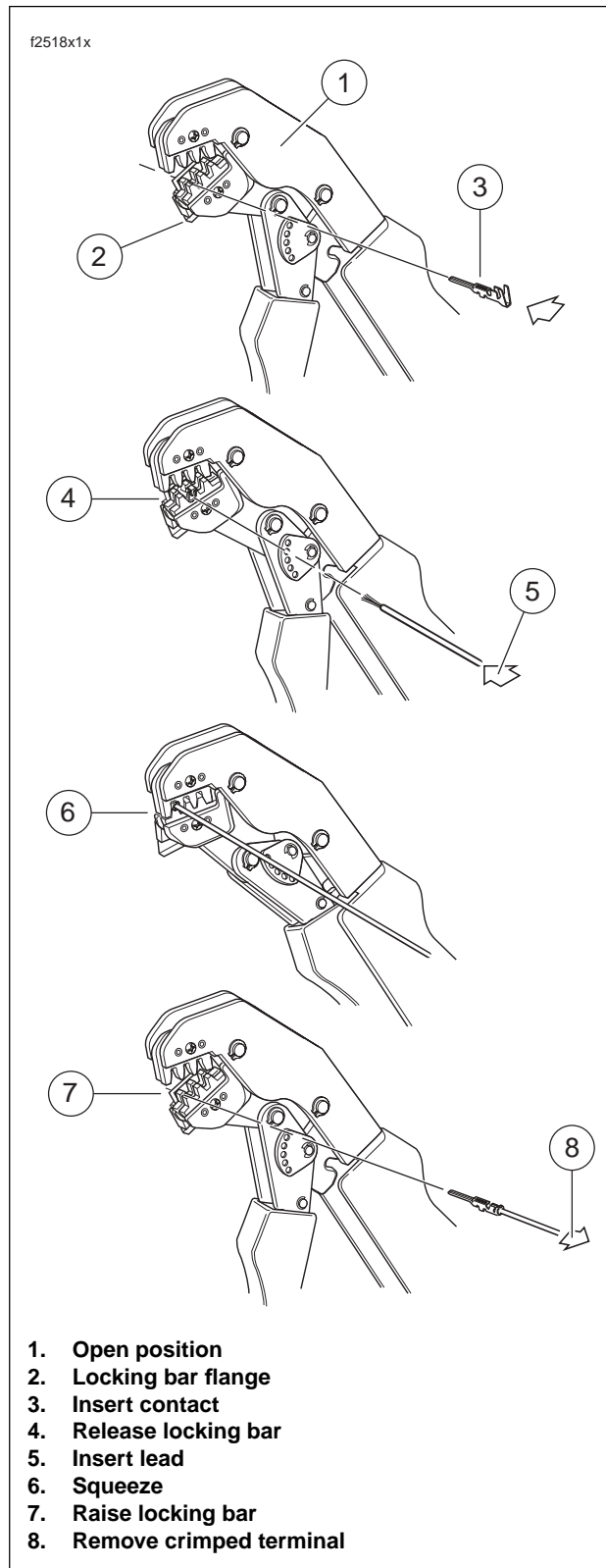


Figure B-6. Multilock Crimping Procedure

INSPECT CRIMP

See [Figure B-7](#). Inspect the wire core (1) and insulation crimps (2). Distortion should be minimal.

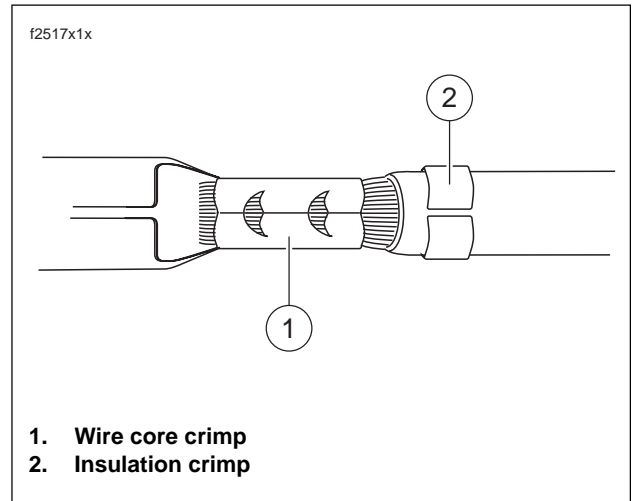


Figure B-7. Terminal Crimp

GENERAL

Deutsch connectors are colored coded for location purposes. Those connectors associated with **left** side accessories, such as the front and rear **left** turn signals, are **gray**. All other connectors, including those associated with right side accessories, are black.

PART NO.	SPECIALTY TOOL
HD-42879	Electrical crimp tool
HD-41475	Deutsch terminal repair kit
HD-38125-7	Packard terminal crimper

NOTE

A Deutsch Connector Service Kit (HD-41475) contains a selection of wire seals, internal seals, seal plugs, secondary locking wedges, attachment clips and socket/pin terminals. Also included is a compartmented storage box, carrying case and pick tool (HD-41475-100) used for the removal of all types of locking wedges.

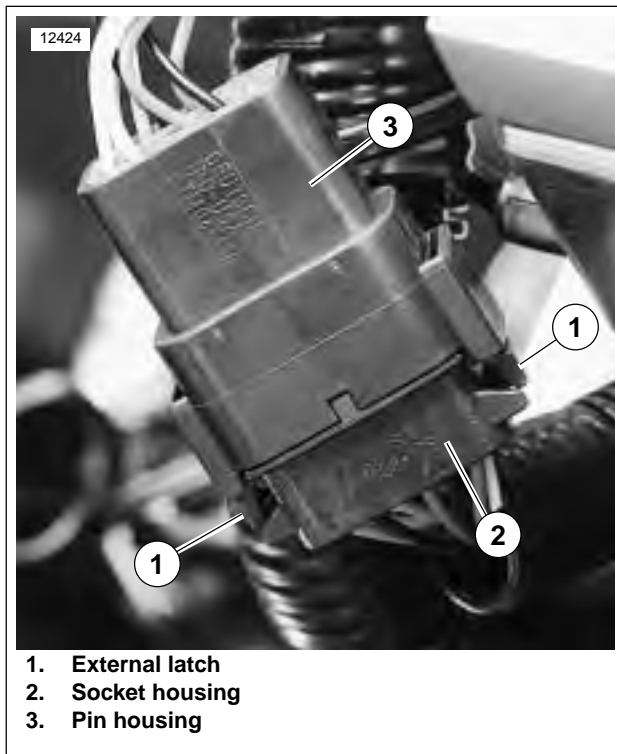


Figure B-8. Deutsch Electrical Connector

PIN AND SOCKET HOUSINGS

Separate Housings

See [Figure B-8](#). To separate the connector halves, depress the external latch(es) (1) on the socket housing (2) while rocking the pin (3) and socket housings.

NOTES

- Generally, the socket housing is found on the accessory side, while the pin housing is plumbed to the wiring harness.
- Two-, three-, four- and six-place Deutsch connectors have one latch on the connector.
- Eight- and twelve-place connectors have a latch on each side. Simultaneously press both latches to separate the connector.

Mate Housings

1. Align the connectors to match the wire lead colors.

For One External Latch: Two-, three-, four- and six-place Deutsch connectors have one external latch on the socket half of the connector. To fit the halves of the connector together, the latch on the socket side must be aligned with the latch cover on the pin side.

For Two External Latches: (8-place and 12-place) Align the tabs on the socket housing with the grooves on the pin housing.

2. Insert socket housing into pin housing until it snaps or clicks into place.

For Two External Latches: (8-place and 12-place) If latches do not click (latch), press on one side of the connector until that latch engages, then press on the opposite side to engage the other latch.

3. If necessary, fit the attachment clip to the pin housing.
4. Place large end of slot on attachment clip over T-stud on frame. Push assembly forward to engage small end of slot.

WIRE TERMINALS

Remove Socket Terminals

1. See [Figure B-9](#). Insert a small screwdriver between the socket housing and locking wedge in-line with the groove (in-line with the pin holes if the groove is absent). Turn the screwdriver 90 degrees to pop the wedge up and remove the secondary locking wedge.
2. Use a pick or small screwdriver to depress terminal latches inside socket housing and back out sockets through holes in rear wire seal. See [Figure B-12](#).

NOTE

If wire leads require new terminals, go to [TERMINAL CRIMPS](#).



Figure B-9. Remove Secondary Locking Wedge

Install Socket Terminals

1. Match wire lead color to connector cavity.
2. See [Figure B-11](#). Fit rear wire seal (1) into back of socket housing (2), if removed.
3. Grasp wire lead approximately 1 in. (25.4 mm) behind the socket terminal (3). Gently push socket through hole in wire seal into its chambers until it “clicks” in place.
4. A tug on the wire will confirm that it is properly locked in place.

NOTE

Seal plugs (6) are installed through the wire seals of unused chambers. If removed, seal plugs must be replaced to seal the connector.

5. Install internal seal (4) on lip of socket housing, if removed.
6. Insert tapered end of secondary locking wedge (5) into socket housing and press down until it snaps in place. The wedge fits into the center groove within the socket housing and holds the terminal latches tightly closed.

NOTES

- See [Figure B-10](#). While rectangular wedges do not require a special orientation, the conical secondary locking wedge of the 3-place connector must be installed with the arrow (1) pointing toward the external latch.
- If the secondary locking wedge does not slide into the installed position easily, verify that all terminals are fully installed in the socket housing. The lock indicates when terminals are not properly installed by not entering its fully installed position.

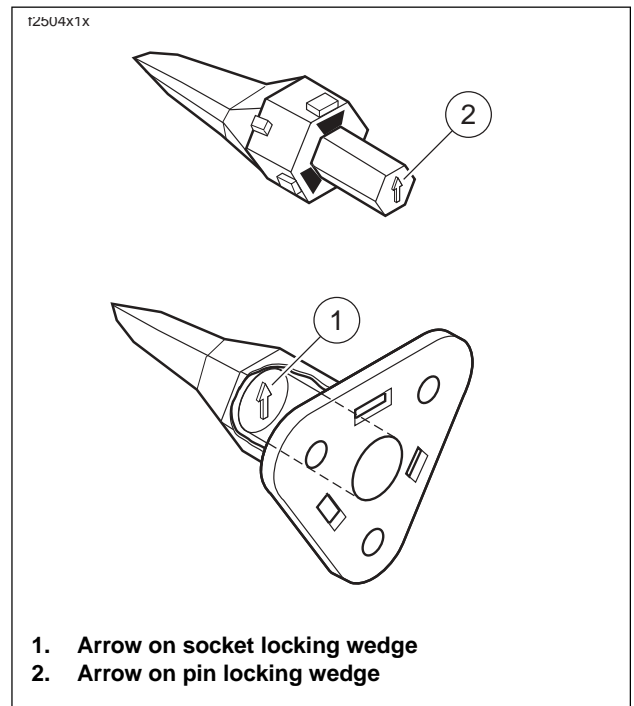


Figure B-10. 3-Place Locking Wedges

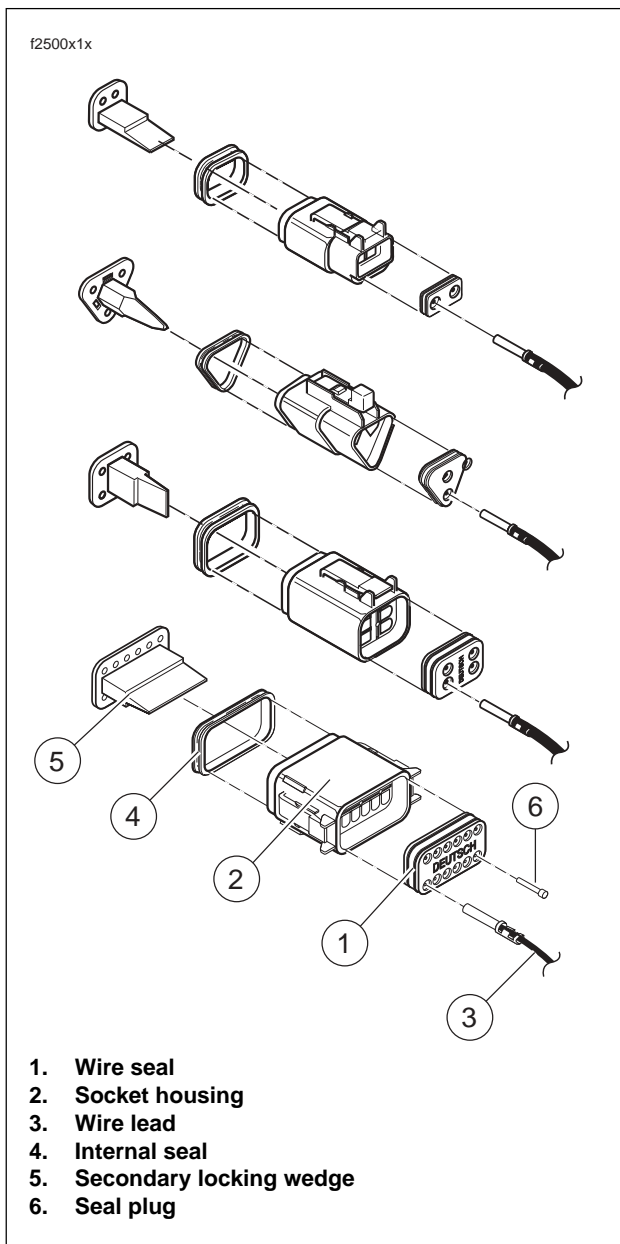


Figure B-11. Two, Three, Four and Six Place Socket Housings

Remove Pin Terminals

1. Use the hooked end of a stiff piece of mechanics wire, a needle nose pliers or a suitable pick tool (HD-41475-100) to remove the secondary locking wedge.
2. Gently depress terminal latches inside pin housing and back out pins through holes in wire seal.

NOTES

- If wire leads require new terminals, go to [TERMINAL CRIMPS](#).
- If it should become necessary to replace a pin or socket housing, please note that the 8-place and 12-place gray and black connectors are not interchangeable. Since location of the alignment tabs differ between the black and gray connectors, plugs or receptacles must be replaced by those of the same color.
- When replacing both socket and pin housings, then the black may be substituted for the gray, and vice versa. The socket and pin housings of all other connectors are interchangeable, that is, the black may be mated with the gray, since the alignment tabs are absent and the orientation of the external latch is the same.

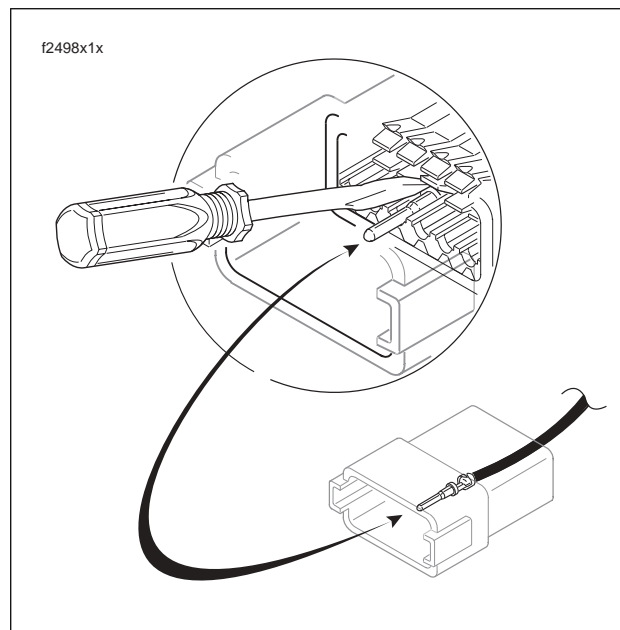


Figure B-12. Depress Terminal Latch & Back Out Pin

Install Pin Terminals

1. See [Figure B-13](#). Fit wire seal (1) into back of pin housing (2).
2. Grasp wire lead approximately 1 in. (25.4 mm) behind the pin terminal (3). Gently push pin through holes in wire seal into its respective numbered chamber until it “clicks” in place.

NOTE

A tug on the wire lead will confirm that a pin is locked in place.

3. Insert tapered end of secondary locking wedge (5) into pin housing and press down until it snaps in place.

NOTES

- The wedge fits in the center groove of the pin housing and holds the terminal latches tightly closed.
- See [Figure B-10](#). While rectangular wedges do not require a special orientation, the conical secondary locking wedge of the 3-place connector must be installed with the arrow (2) pointing toward the external latch.
- If the secondary locking wedge does not slide into the installed position easily, verify that all terminals are fully installed in the pin housing. The lock indicates when terminals are not properly installed by not entering its fully installed position.

TERMINAL CRIMPS

Refer to [Table B-3](#). Identify which of the types of Deutsch terminals are used with the connector and follow the corresponding crimping instructions.

Table B-3. Deutsch Terminal Crimping Instructions: 2007 Buell Blast

TYPE	CRIMPING INSTRUCTIONS
Standard (with crimp tails)	B.4 DEUTSCH STANDARD TERMINAL
Mini-Deutsch (with crimp tails)	N/A
Solid barrel (without crimp tails)	N/A

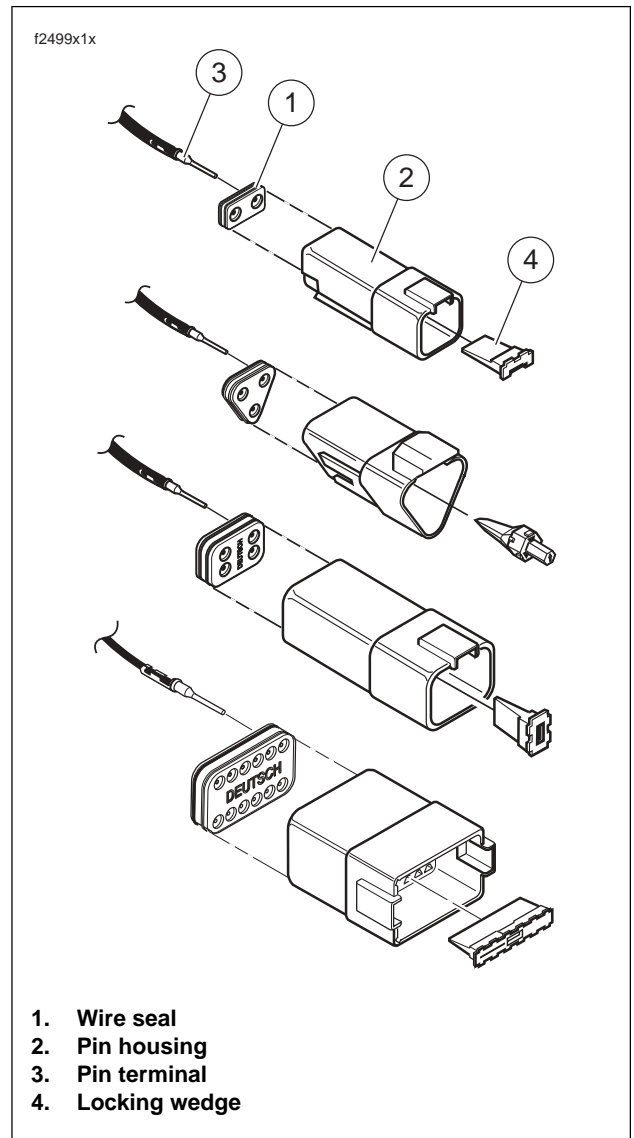


Figure B-13. 2, 3, 4 and 12 Place Pin Housings

PREPARE WIRE LEAD

1. Use a shop gauge to determine gauge of wire lead.
2. Strip lead removing 5/32 inch (4.0 mm) of insulation.

CRIMP TERMINAL TO LEAD

1. See [Figure B-14](#). Squeeze the handles of the DEUTSCH TERMINAL CRIMP TOOL (HD-39965) to open the jaws. Push the locking bar (1) up.
2. Insert (2) terminal (socket/pin) through hole of the locking bar, so that the rounded side of the contact barrel rests in the die (concave split level area) with the crimp tails facing upward. To match the wire gauge to the crimp tool die, refer to [Table B-4](#).

Table B-4. Wire Gauge to Die

Wire Gauge (AWG)	Crimp Tool Die
20	Front
16-18	Middle

3. Release locking bar to lock terminal in die.

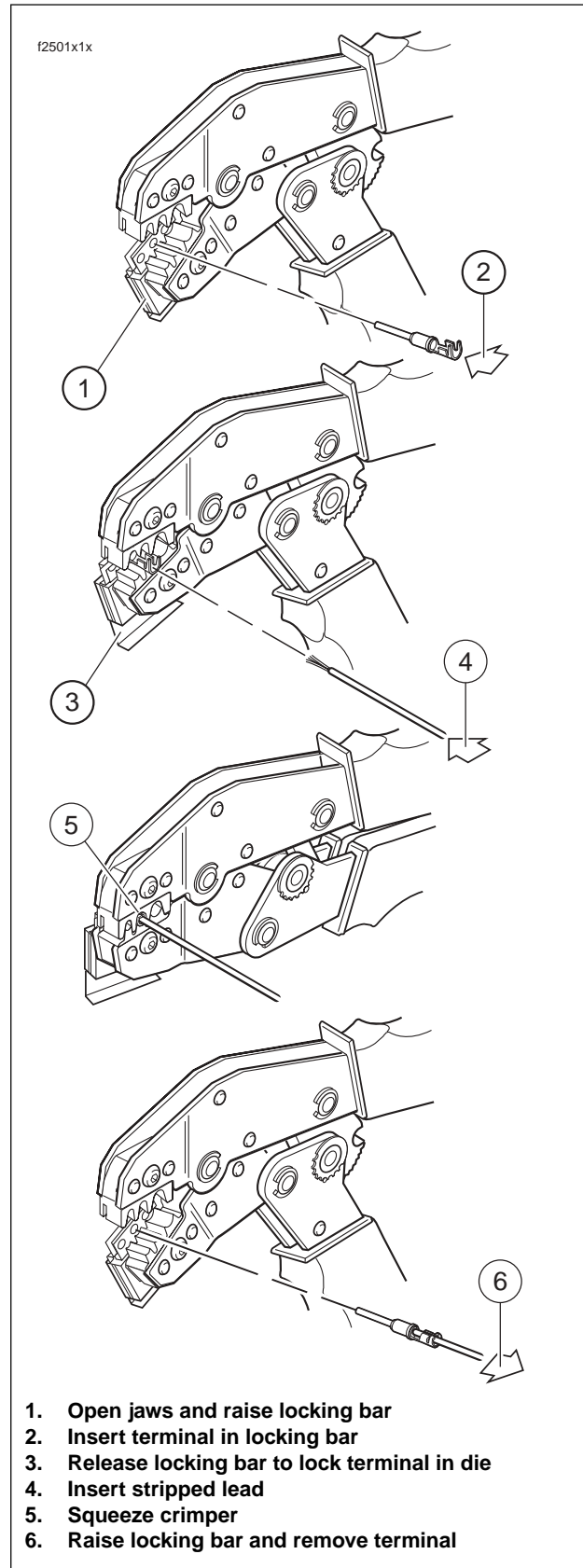
NOTE

If the crimp tails are slightly out of vertical alignment, the crimp tool automatically rotates the terminal so that the tails face straight upward. When positioned, the locking bar fits snugly in the space between the contact band and the core crimp tails.

4. Insert stripped wire core between crimp tails until ends make contact with locking bar. Verify that wire is positioned so that short pair of crimp tails squeeze bare wire strands, while long pair folds over the insulation.
5. Squeeze handle of crimp tool until tightly closed. Tool automatically opens after the terminal is crimped.
6. Raise locking bar up and remove wire lead and terminal.

INSPECT CRIMP

Inspect the wire core and insulation crimps. Distortion should be minimal.



1. Open jaws and raise locking bar
2. Insert terminal in locking bar
3. Release locking bar to lock terminal in die
4. Insert stripped lead
5. Squeeze crimper
6. Raise locking bar and remove terminal

Figure B-14. Crimping a Deutsch Standard Terminal

GENERAL

Splice connectors and several OE ring terminal connectors use heat shrink covering to seal the connection.

PREPARE THE WIRE LEADS

PART NO.	SPECIALTY TOOL
HD-38125-8	Packard crimping tool
HD-39969	Ultra-torch
HD-25070	Heat gun
HD-41183	Heat shield attachment

NOTE

If adjacent wires are to be spliced, stagger the splices so that the sealed splice connectors will not touch each other but are located at different positions along the length of the wires.

1. Identify (use a shop gauge) the gauge of the wire.
2. Match the wire gauge to a sealed splice connector by color and part number. Refer to [Table B-5](#).
3. Using a wire stripper, cut and strip a length of insulation off the wire ends. Refer to [Table B-5](#) for the strip length.

Table B-5. Sealed Splice Connectors

Wire Gauge	Connector Color	Connector Part No.	Strip Length
18-20 (0.5-0.8 mm)	Red	70585-93	3/8 in. (9.5 mm)
14-16 (1.0-2.0 mm)	Blue	70586-93	3/8 in. (9.5 mm)
10-12 (3.0-5.0 mm)	Yellow	70587-93	3/8 in.? (9.5 mm)

NOTE

If any copper wire strands are cut off of the wire core, trim the end and strip the wire again in a larger gauge stripper.

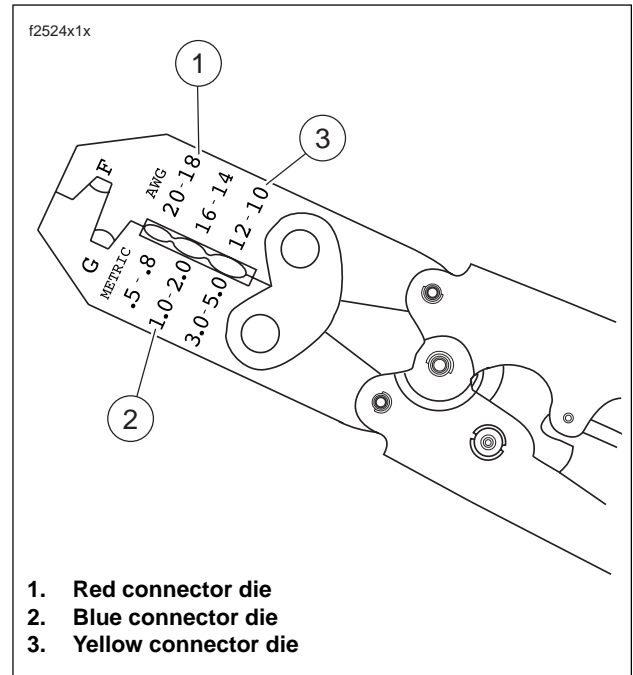


Figure B-15. Packard Crimping Tool (HD-38125-8)

SPLICING WIRE LEADS

NOTE

See [Figure B-16](#). The connector is crimped twice - one side and then the other.

1. See [Figure B-15](#). Open the Packard Crimping Tool (HD-38125-8) ratchet by squeezing the handles closed.
2. Match the connector color to the wire gauge crimp die in the jaws and insert one end of the sealed connector.
3. Gently squeeze the handles until the connector is held in the jaws.
4. See [Figure B-16](#). Feed the stripped end of a wire into the connector until the wire stops inside the metal insert (1).
5. Squeeze the handles tightly closed to crimp the lead in the insert (2). The tool automatically opens when the crimping is complete.
6. Slide the connector to the other half of the metal insert. Insert the stripped wire lead (1) until it stops, and crimp the lead in the insert (2).

WARNING

Be sure to follow manufacturer's instructions when using the Ultra-Torch UT-100 or any other radiant heating device. Failure to follow manufacturer's instructions can cause a fire, which could result in death or serious injury. (00335a)

- Avoid directing heat toward any fuel system component. Extreme heat can cause fuel ignition/explosion resulting in death or serious injury.
 - Avoid directing heat toward any electrical system component other than the connectors on which heat shrink work is being performed.
 - Always keep hands away from tool tip area and heat shrink attachment.
7. Use an Ultra-Torch (HD-39969), or a Heat Gun (HD-25070) with a Heat Shield Attachment (HD-41183), to heat the connector from the center of the crimp (3), out to each end.

NOTE

It is acceptable for the splice to rest against the heat shrink tool attachment.

INSPECT SEAL

See [Figure B-16](#). Allow the splice to cool and inspect the seal. The insulation should appear smooth and cylindrical. Melted sealant will have extruded out the ends (4) of the insulation.

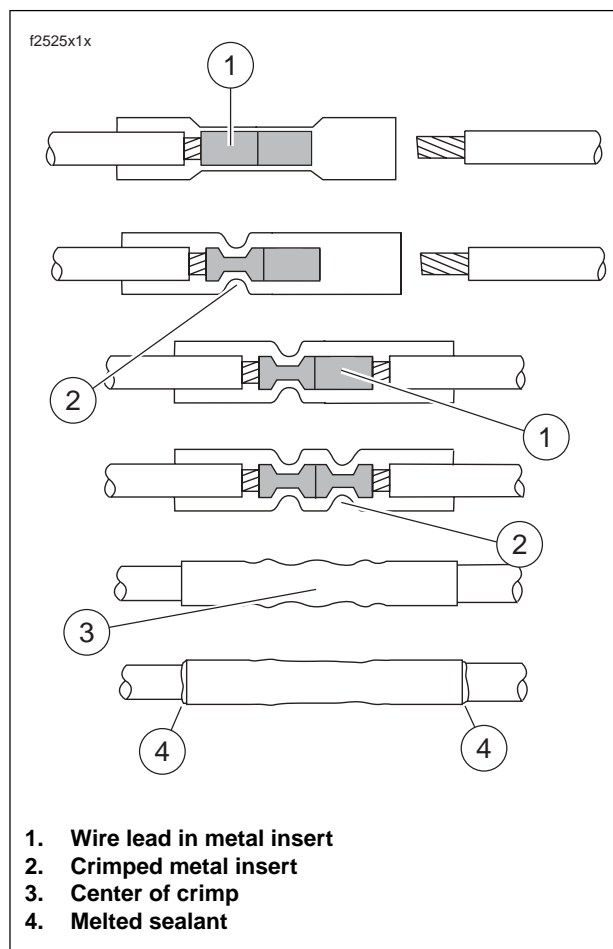


Figure B-16. Sealed Splice Connector

WIRE COLOR CODES

Wire traces on wiring diagrams are labeled with alpha codes. Refer to Table B-6.

For Solid Color Wires: See Figure B-17. The alpha code identifies wire color (3).

For Striped Wires: The code is written with a slash (/) between the solid color code and the stripe code (4). For example, a trace labeled GN / Y is a green wire with a yellow stripe.

WIRING DIAGRAM SYMBOLS

See Figure B-17. On wiring diagrams and in service/repair instructions, connectors are identified by a number in brackets (1). The letter (2) inside the brackets identifies whether the housing is a socket or pin housing.

A=Pin: The letter A after a connector number and/or the pin symbol (5) identifies a pin housing.

B=Socket: The letter B after a connector number and/or the socket symbol (6) identifies a socket housing.

Other symbols found on the wiring diagrams include the symbol for a diode (7), a symbol for a wire-to-wire connection (8) and a symbol that verifies that no connection (9) between two wire traces exists.

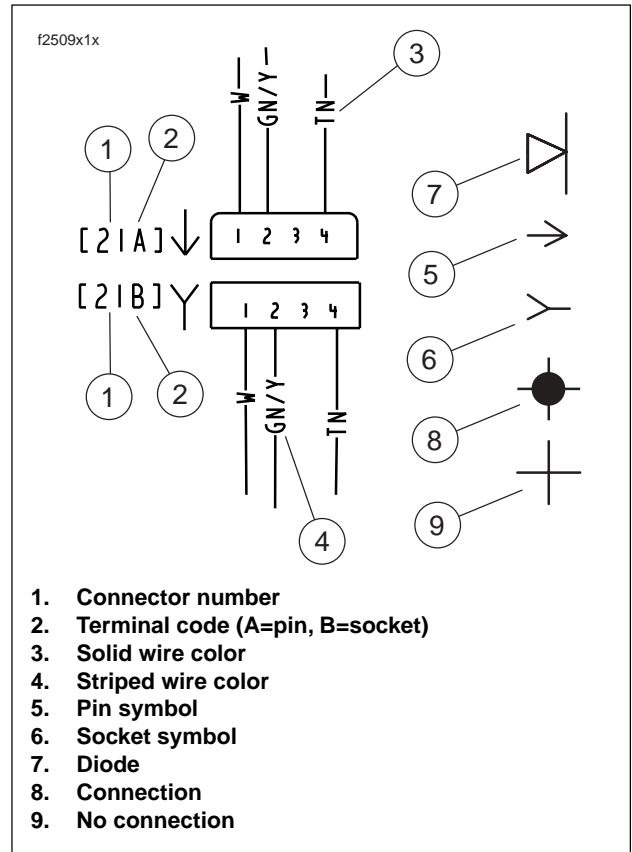


Figure B-17. Connector/Wiring Diagram Symbols (typical)

Table B-6. Wire Color Codes

Alpha Code	Wire Color
BE	Blue
BK	Black
BN	Brown
GN	Green
GY	Grey
LGN	Light Green
O	Orange
PK	Pink
R	Red
TN	Tan
V	Violet
W	White
Y	Yellow

Table B-7. Wiring Diagram Index

DIAGRAM/CIRCUIT	PAGE
Main harness	Figure B-18. 2007 Buell Blast P3 Model - Main Harness
Starting circuit	Figure B-19. 2007 Buell Blast P3 Model - Starting
Charging circuit	Figure B-20. 2007 Buell Blast P3 Model - Charging
Horn and instruments circuit	Figure B-21. 2007 Buell Blast P3 Model - Horn and Instruments
Lighting circuit	Figure B-22. 2007 Buell Blast P3 Model - Lighting
Ignition circuit	Figure B-23. 2007 Buell Blast P3 Model - Ignition

a0280a7x

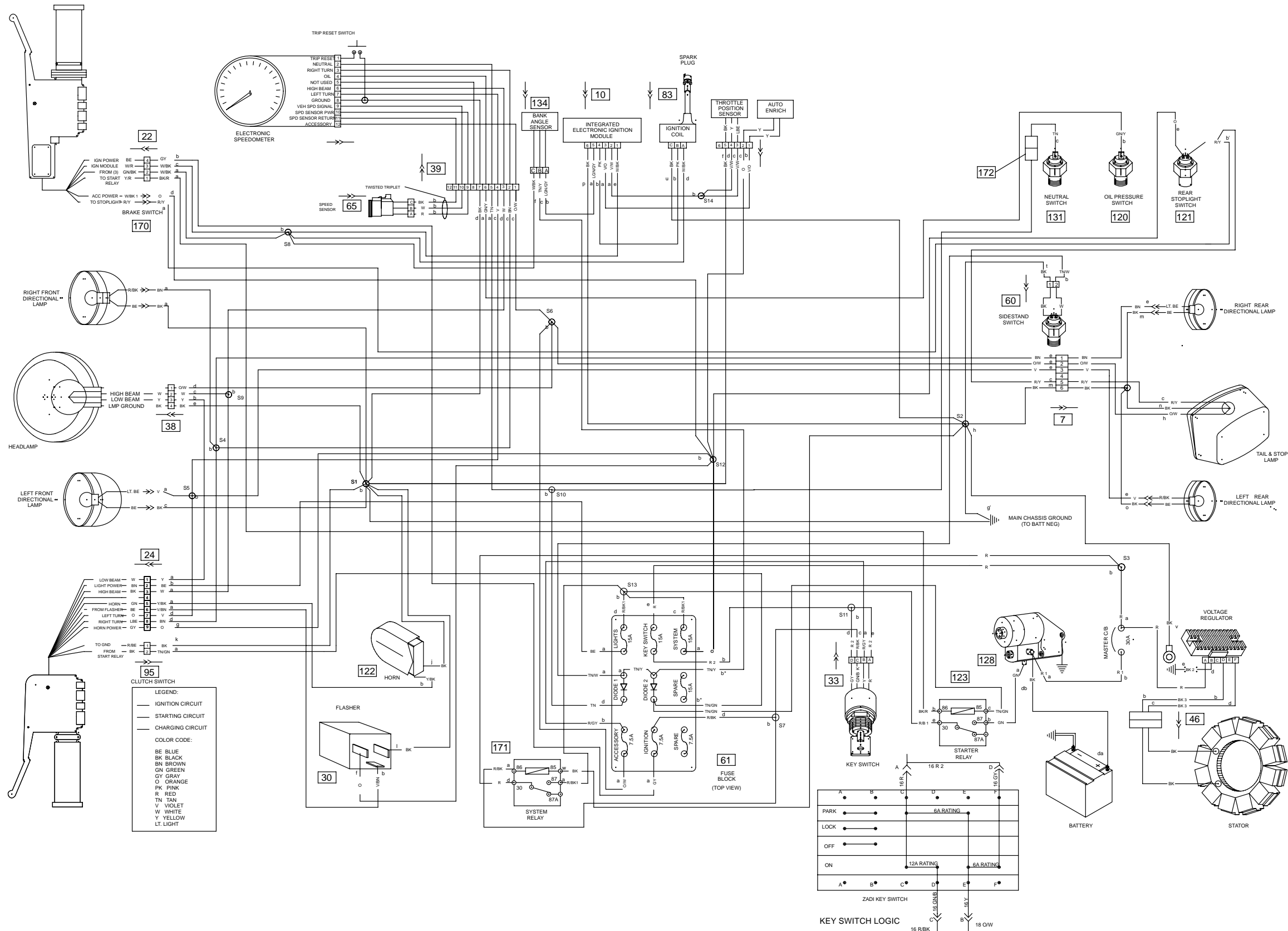


Figure B-18. 2007 Buell Blast P3 Model - Main Harness

2007 Buell Blast P3 Model - Main Harness

2007 Buell Blast P3 Model - Main Harness

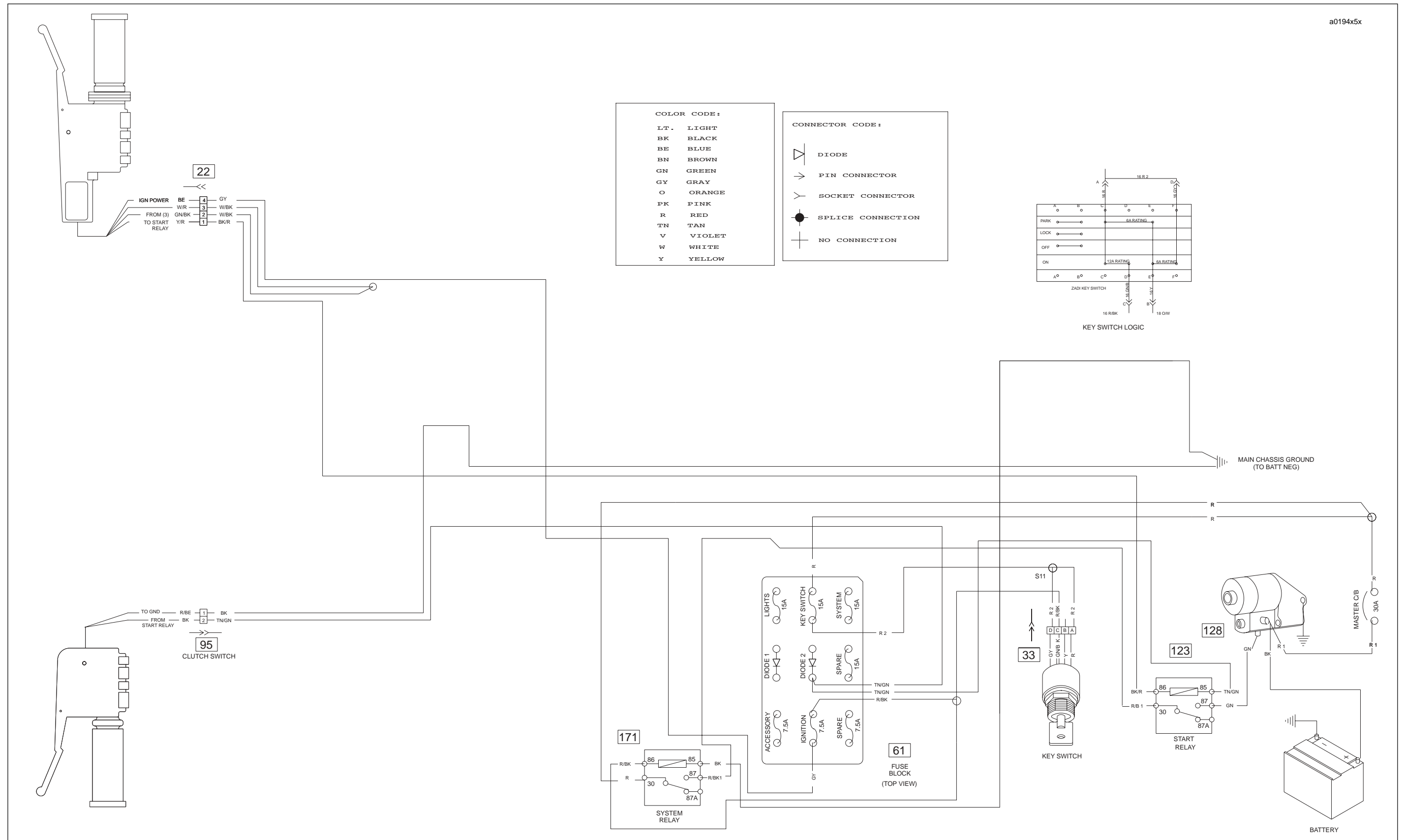


Figure B-19. 2007 Buell Blast P3 Model - Starting

2007 Buell Blast P3 Model - Starting

2007 Buell Blast P3 Model - Starting

a0278x7x

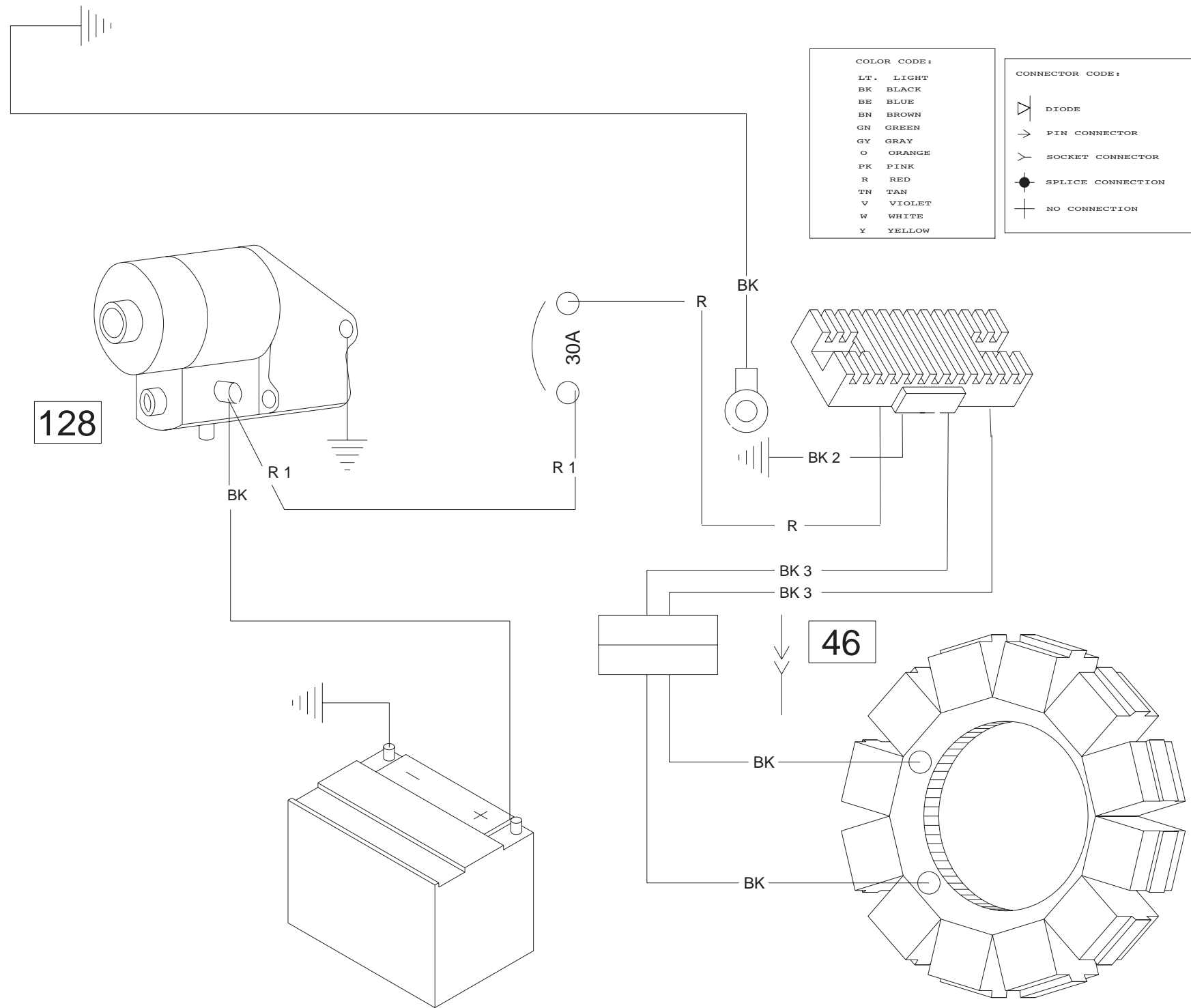


Figure B-20. 2007 Buell Blast P3 Model - Charging

2007 Buell Blast P3 Model - Charging

2007 Buell Blast P3 Model - Charging

a0279x7x

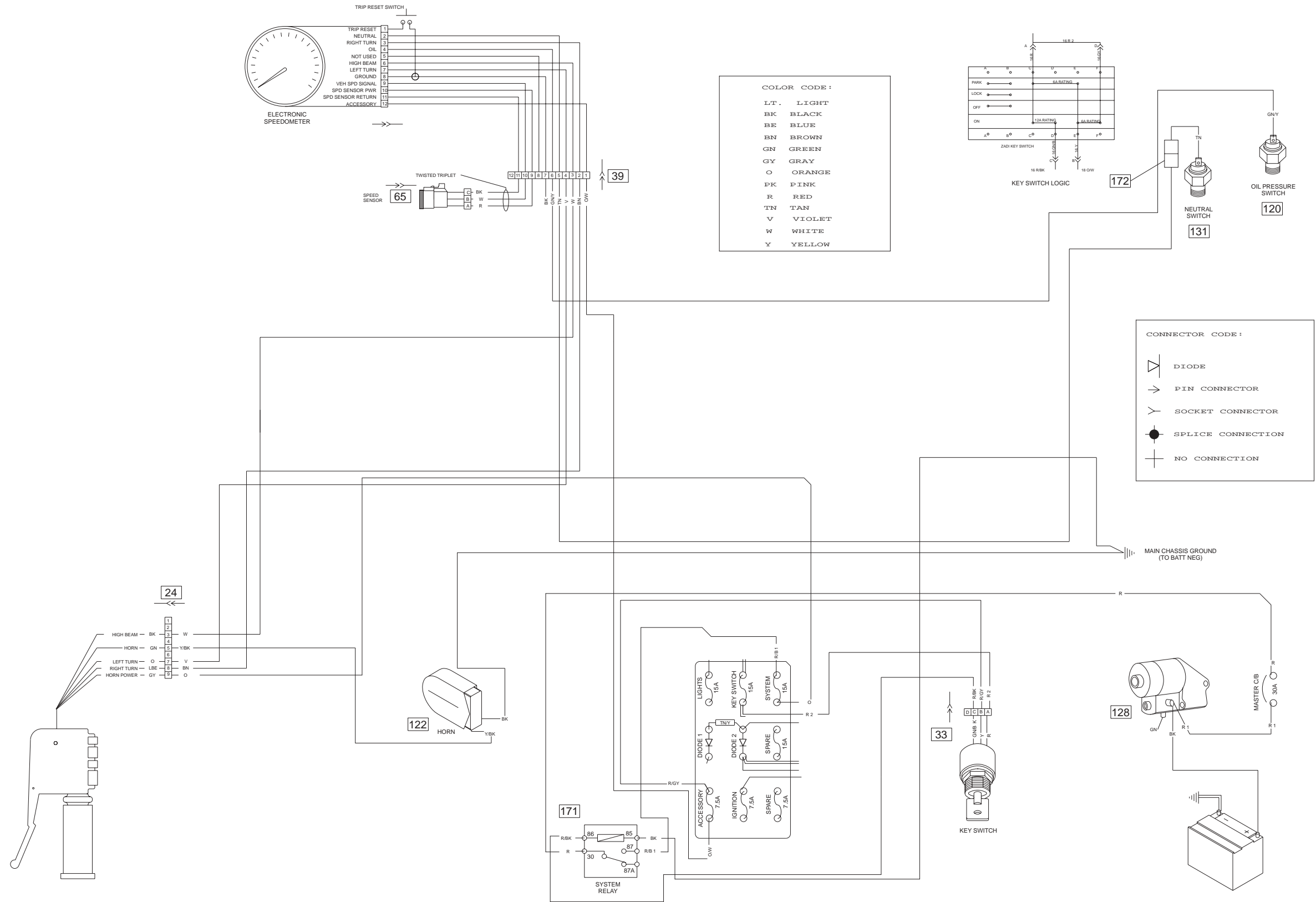


Figure B-21. 2007 Buell Blast P3 Model - Horn and Instruments

2007 Buell Blast P3 Model - Horn and Instruments

2007 Buell Blast P3 Model - Horn and Instruments

a0281x7x

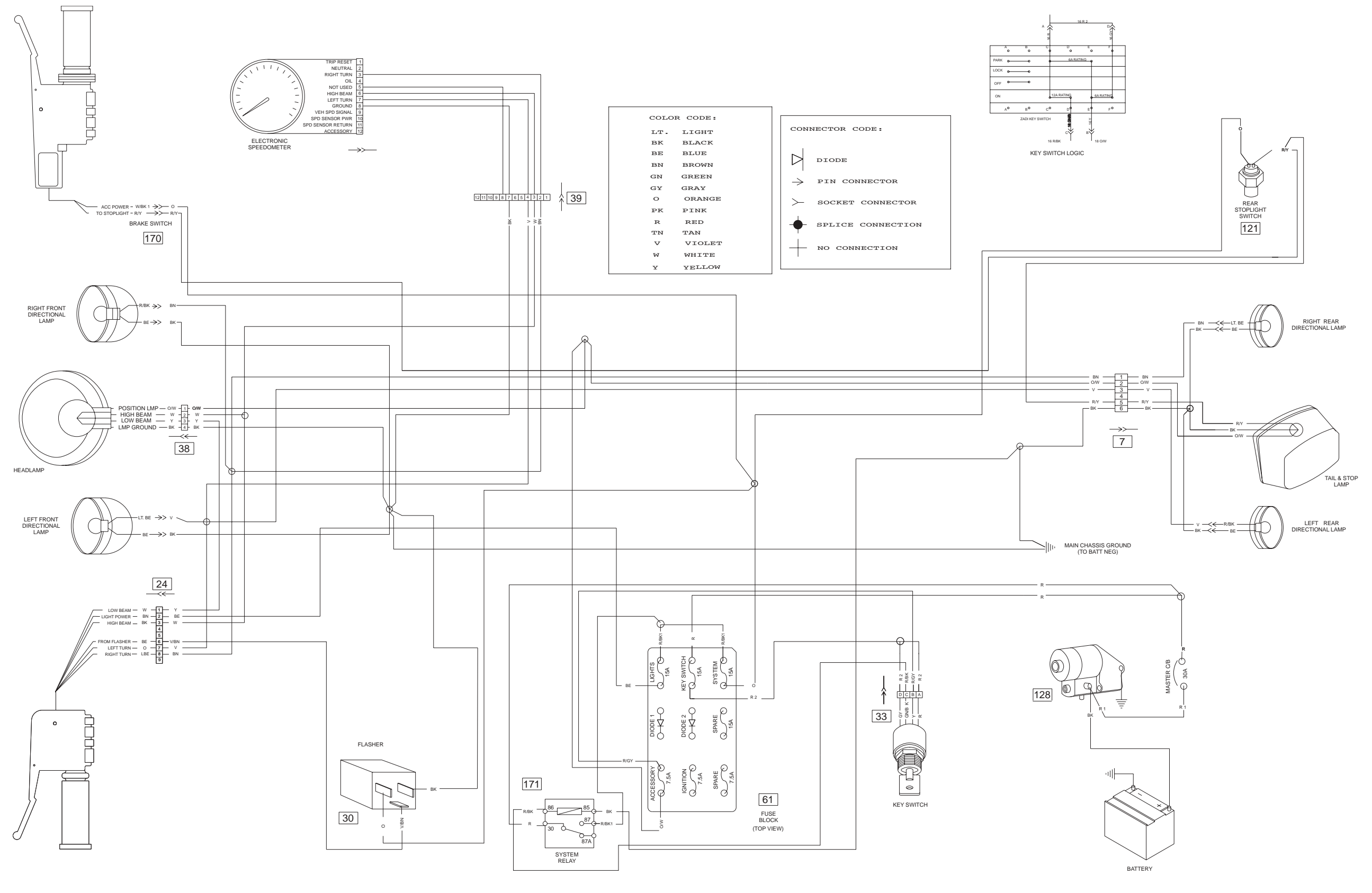


Figure B-22. 2007 Buell Blast P3 Model - Lighting

2007 Buell Blast P3 Model - Lighting

2007 Buell Blast P3 Model - Lighting

a0282a7x

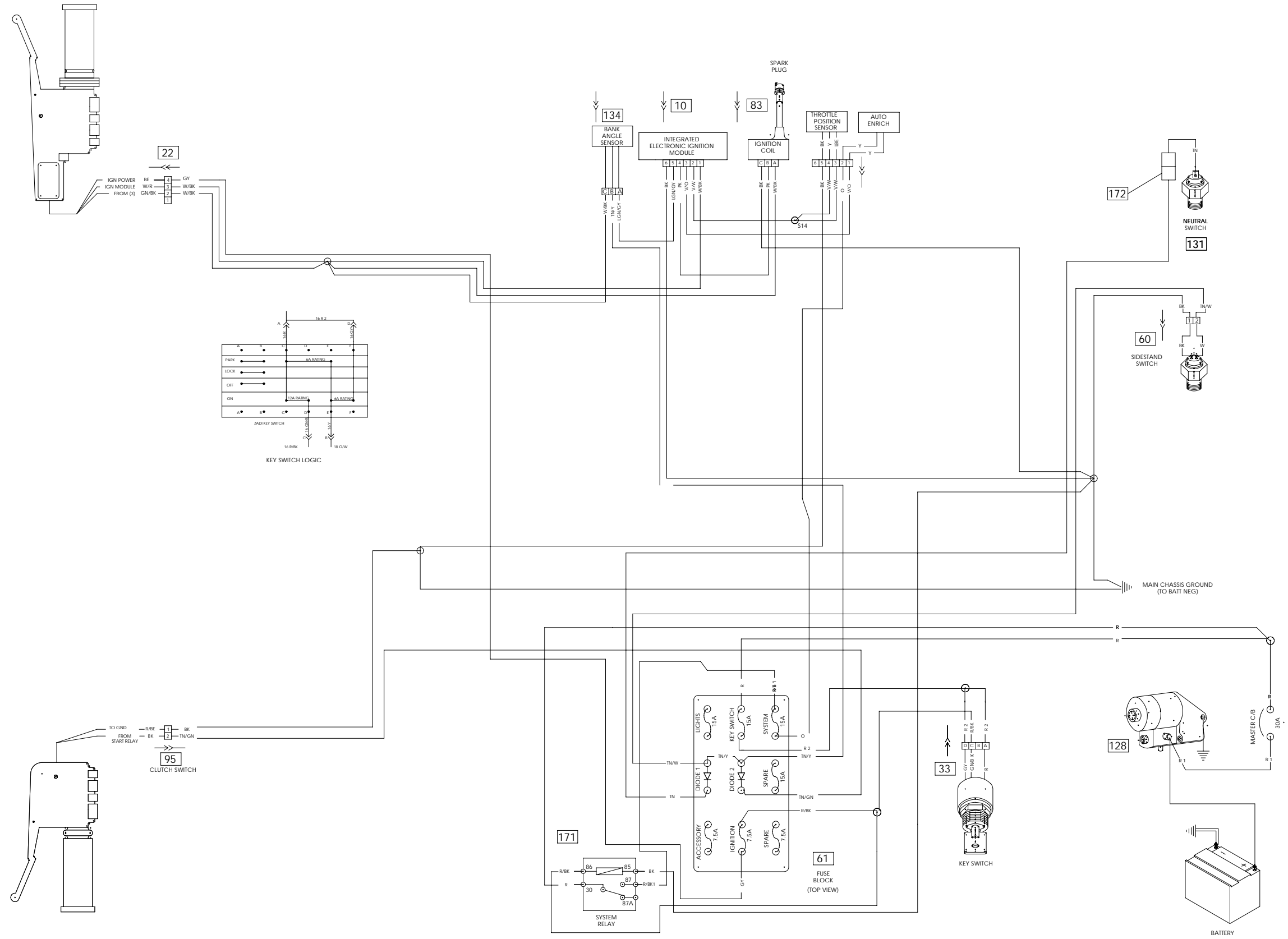


Figure B-23. 2007 Buell Blast P3 Model - Ignition

2007 Buell Blast P3 Model - Ignition

2007 Buell Blast P3 Model - Ignition

a0280a7x

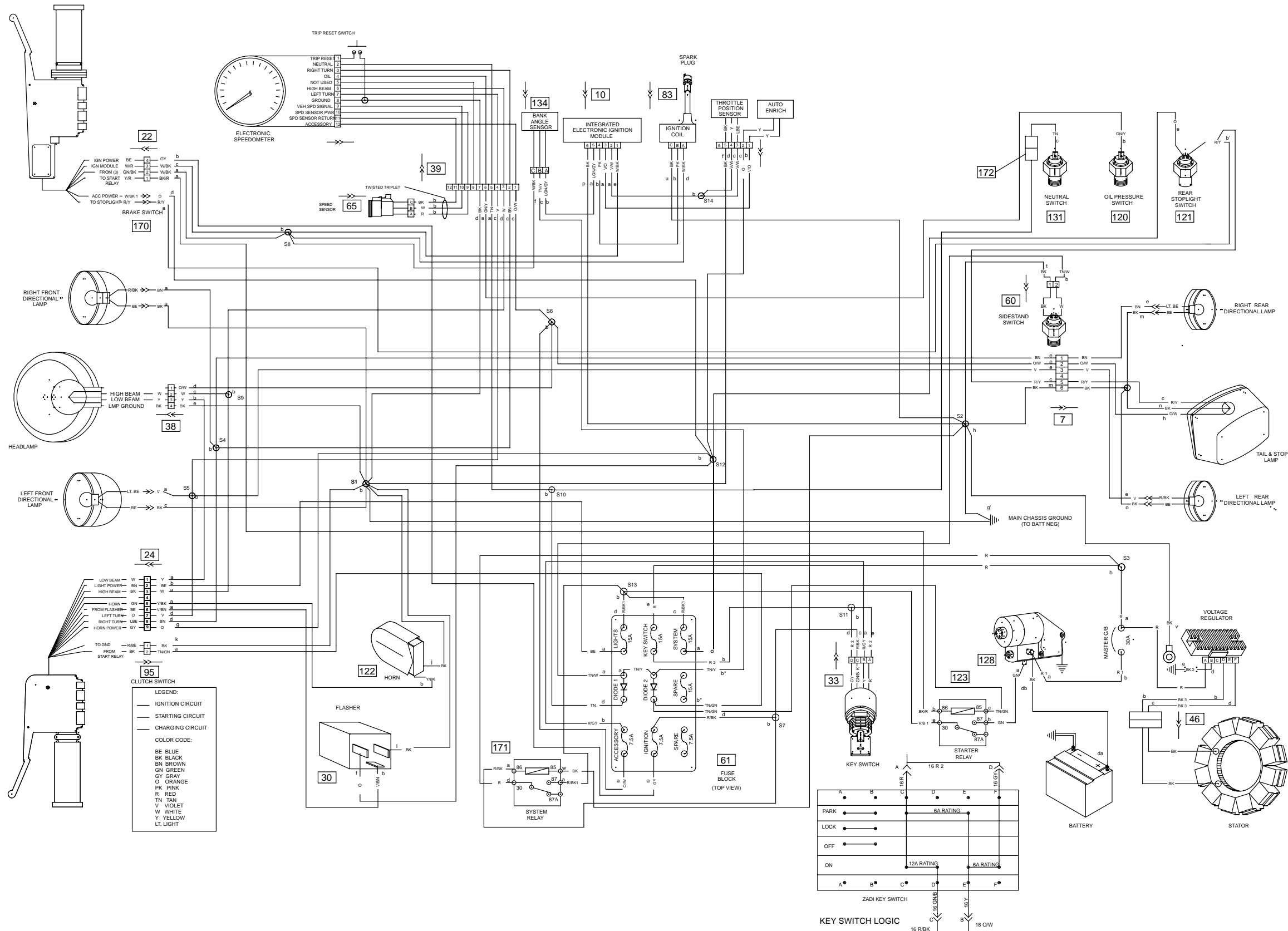


Figure B-18. 2007 Buell Blast P3 Model - Main Harness

2007 Buell Blast P3 Model - Main Harness

2007 Buell Blast P3 Model - Main Harness

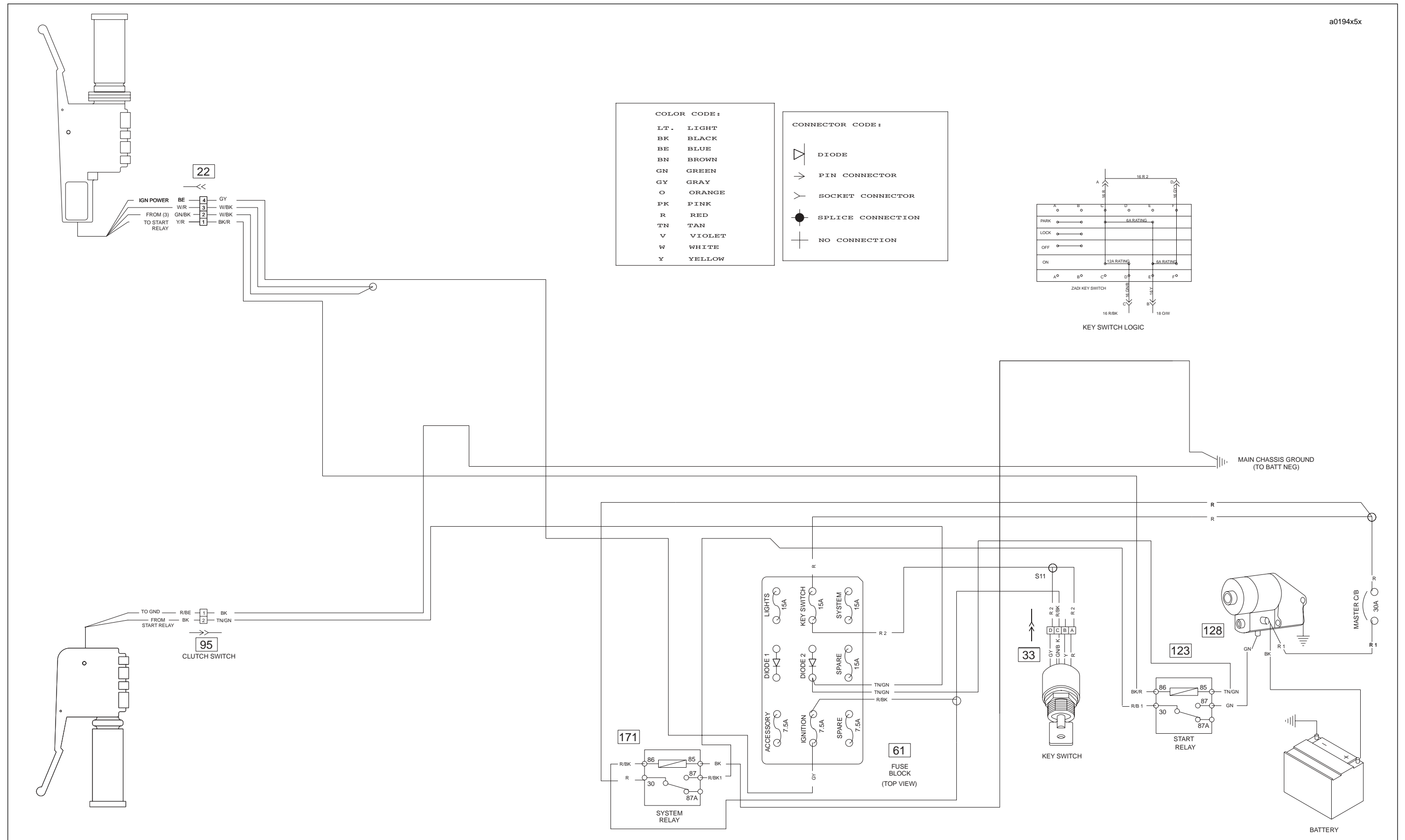


Figure B-19. 2007 Buell Blast P3 Model - Starting

2007 Buell Blast P3 Model - Starting

2007 Buell Blast P3 Model - Starting

a0278x7x

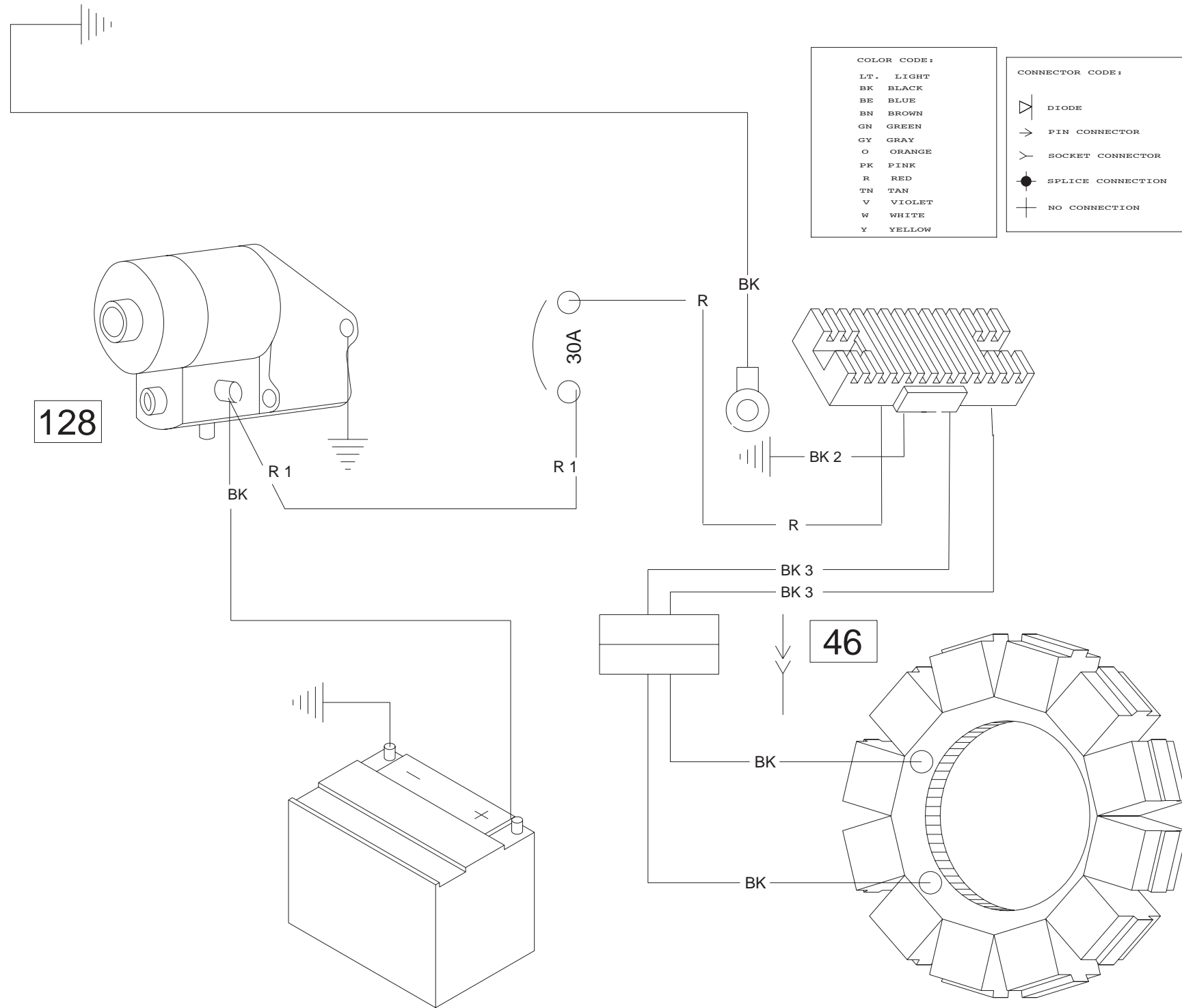


Figure B-20. 2007 Buell Blast P3 Model - Charging

2007 Buell Blast P3 Model - Charging

2007 Buell Blast P3 Model - Charging

a0279x7x

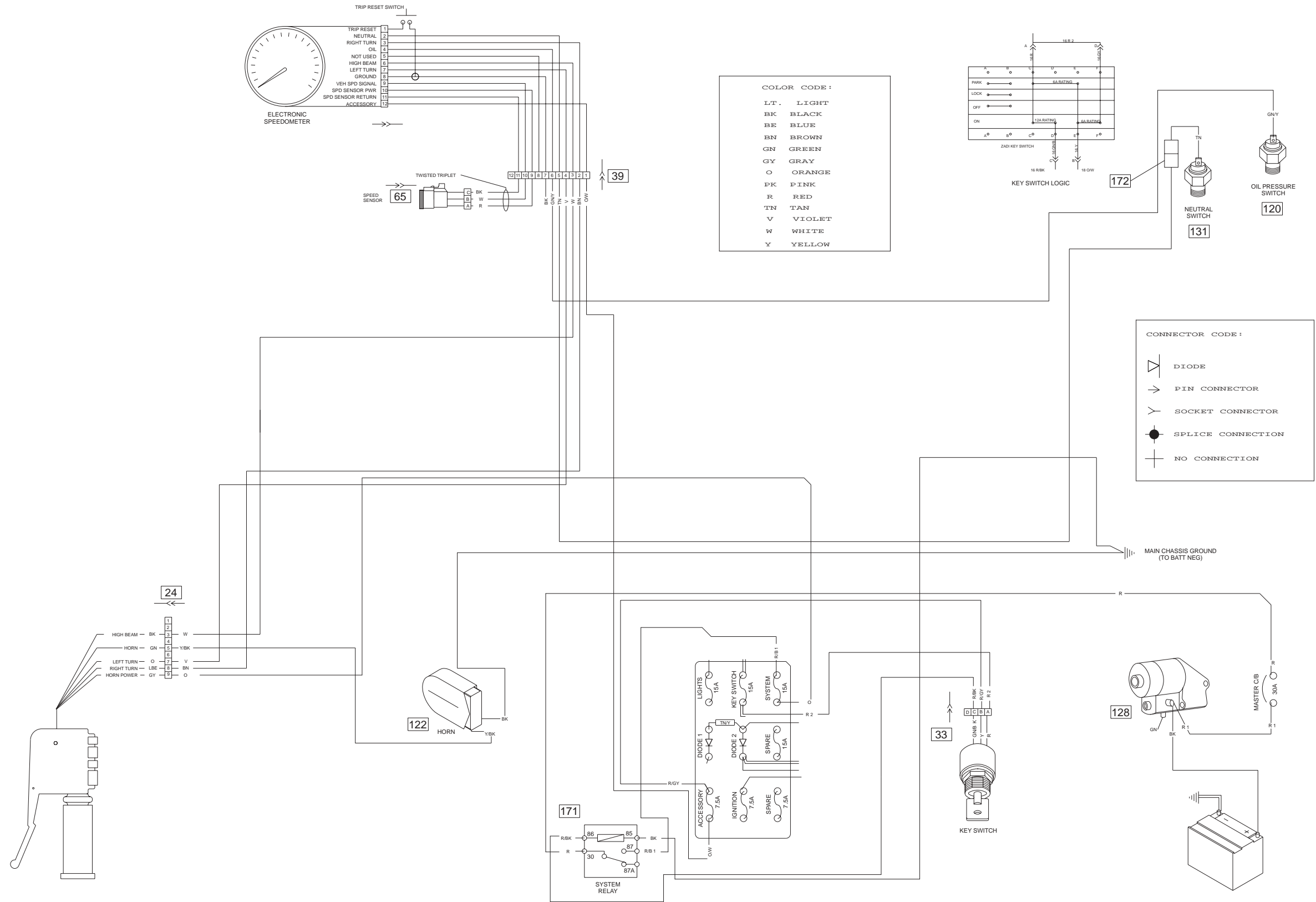


Figure B-21. 2007 Buell Blast P3 Model - Horn and Instruments

2007 Buell Blast P3 Model - Horn and Instruments

2007 Buell Blast P3 Model - Horn and Instruments

a0281x7x

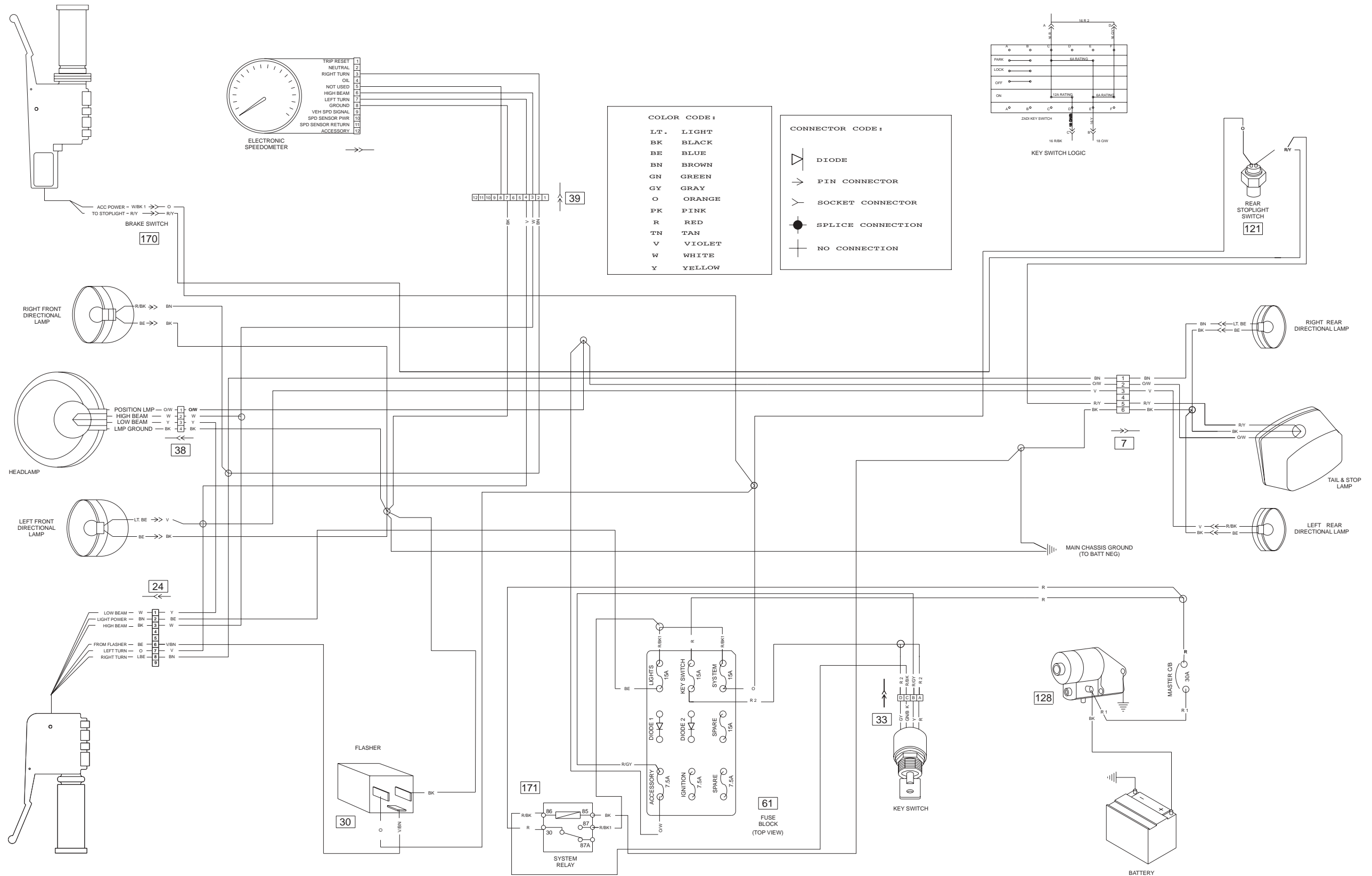


Figure B-22. 2007 Buell Blast P3 Model - Lighting

2007 Buell Blast P3 Model - Lighting

2007 Buell Blast P3 Model - Lighting

a0282a7x

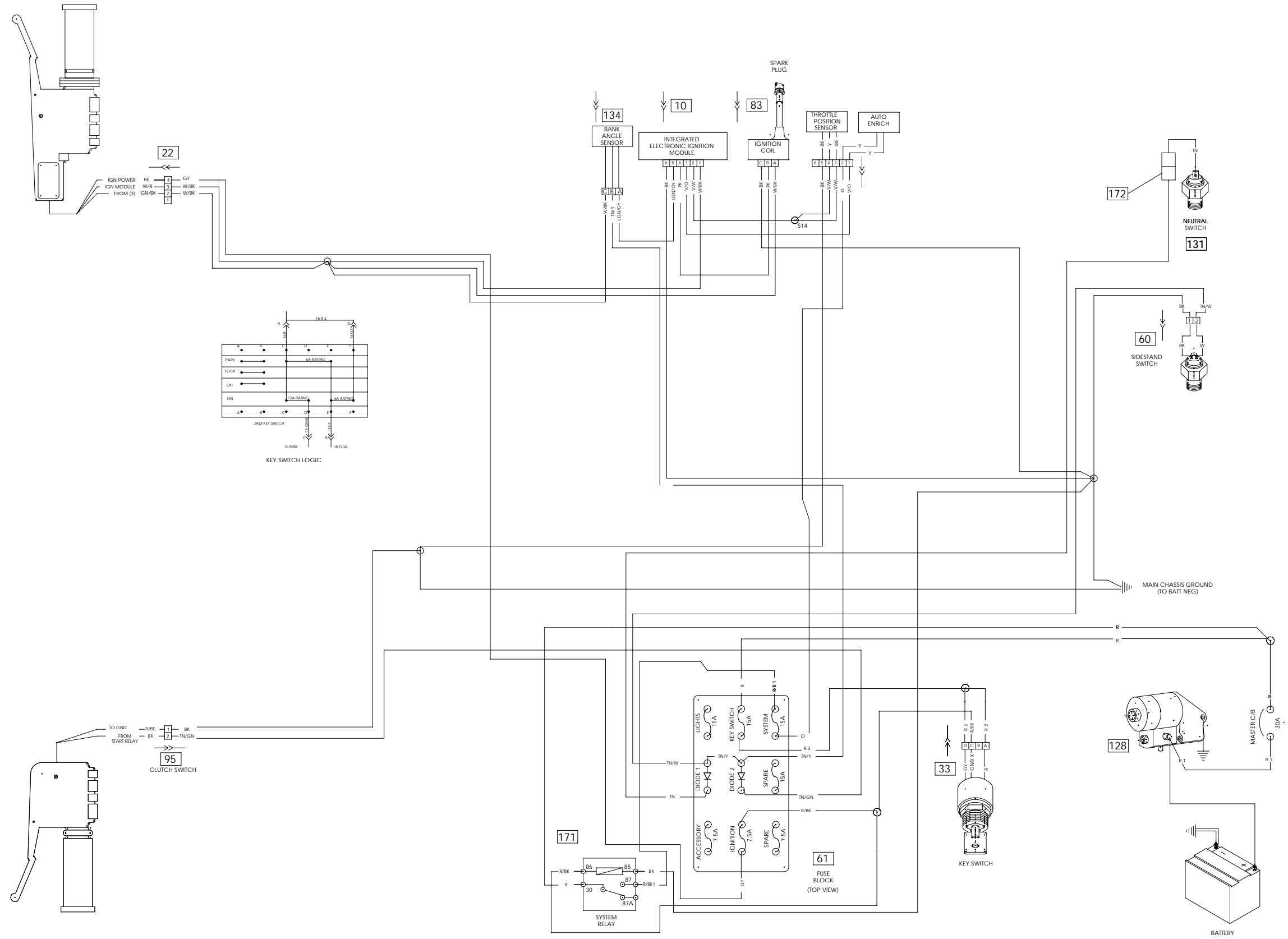


Figure B-23. 2007 Buell Blast P3 Model - Ignition

2007 Buell Blast P3 Model - Ignition

2007 Buell Blast P3 Model - Ignition

SUBJECT	PAGE NO.
1.1 General	1-1
1.2 Fluid Requirements	1-5
1.3 Maintenance Schedule	1-6
1.4 Battery	1-9
1.5 Engine Lubrication System	1-10
1.6 Brake System Maintenance	1-13
1.7 Brakes Pads and Rotors	1-15
1.8 Tires and Wheels	1-16
1.9 Clutch	1-17
1.10 Transmission/Primary Fluid	1-19
1.11 Drive Belt and Rear Sprocket	1-21
1.12 Primary Chain	1-25
1.13 Rear Shock Absorber	1-26
1.14 Front Fork Oil	1-27
1.15 Steering Head Bearings	1-29
1.16 Spark Plug	1-31
1.17 Air Cleaner	1-32
1.18 Throttle Cables	1-34
1.19 Ignition Timing and Idle Speed Adjustment	1-35
1.20 Fuel Supply Valve and Filter Strainer	1-37
1.21 Starter Interlock and Electrical Switches	1-39
1.22 Headlamp	1-40
1.23 Critical Fastener Torque Values	1-41
1.24 Troubleshooting	1-42

SERVICING A NEW MOTORCYCLE

WARNING

Perform the service and maintenance operations as indicated in the regular service interval table. Lack of regular maintenance at the recommended intervals can affect the safe operation of your motorcycle, which could result in death or serious injury. (00010a)

Service operations to be performed before customer delivery are specified in the applicable model year PREDELIVERY AND SETUP MANUAL.

The performance of new motorcycle initial service is required to keep warranty in force and to ensure proper emissions systems operation. See 1.3 MAINTENANCE SCHEDULE for details.

SAFE OPERATING MAINTENANCE

IMPORTANT NOTES

- Do not attempt to retighten engine head bolts. Retightening can cause engine damage.
- During the initial break-in period, use only Harley-Davidson 20W50 engine oil. Failure to use the recommended oil will result in improper break-in of the engine cylinders and piston rings.

A careful check of certain equipment is necessary after periods of storage, and frequently between regular service intervals, to determine if additional maintenance is required.

Check:

1. Tires for abrasions, cuts and correct pressure.
2. Secondary drive belt for proper tension and condition.
3. Brakes, steering and throttle for responsiveness.
4. Brake fluid level and condition. Hydraulic lines and fittings for leaks. Also, check brake pads and rotors for wear.
5. Cables for fraying, crimping and free operation.
6. Engine oil and transmission fluid levels.
7. Headlamp, passing lamp, tail lamp, brake lamp and turn signal operation.

SHOP PRACTICES

Repair Notes

NOTE

- General maintenance practices are given in this section.
- Repair = Disassembly/Assembly.
- Replace = Removal/Installation.

All special tools and torque values are noted at the point of use.

All required parts or materials can be found in the appropriate PARTS CATALOG.

Safety

Safety is always the most important consideration when performing any job. Be sure you have a complete understanding of the task to be performed. Use common sense. Use the proper tools. Protect yourself and bystanders with approved eye protection. Don't just do the job – do the job safely.

Removing Parts

Always consider the weight of a part when lifting. Use a hoist whenever necessary. Do not lift heavy parts by hand. A hoist and adjustable lifting beam or sling are needed to remove some parts. The lengths of chains or cables from the hoist to the part should be equal and parallel and should be positioned directly over the center of the part. Be sure that no obstructions will interfere with the lifting operation. Never leave a part suspended in mid-air.

WARNING

Always check the capacity rating and condition of hoists, slings, chains or cables before use. Failure to do so can lead to an accident which could result in death or serious injury.

Always use blocking or proper stands to support the part that has been hoisted. If a part cannot be removed, verify that all bolts and attaching hardware have been removed. Check to see if any parts are in the way of the part being removed.

When removing hoses, wiring or tubes, always tag each part to ensure proper installation.

Cleaning

If you intend to reuse parts, follow good shop practice and thoroughly clean the parts before assembly. Keep all dirt out of parts; the unit will perform better and last longer. Seals, filters and covers are used in this vehicle to keep out environmental dirt and dust. These items must be kept in good condition to ensure satisfactory operation.

Clean and inspect all parts as they are removed. Be sure all holes and passages are clean and open. After cleaning, cover all parts with clean lint-free cloth, paper or other material. Be sure the part is clean when it is installed.

Always clean around lines or covers before they are removed. Plug, tape or cap holes and openings to keep out dirt, dust and debris.

Disassembly and Assembly

Always assemble or disassemble one part at a time. Do not work on two assemblies simultaneously. Be sure to make all necessary adjustments. Recheck your work when finished. Be sure that everything is done.

Operate the vehicle to perform any final check or adjustments. If all is correct, the vehicle is ready to go back to the customer.

REPAIR AND REPLACEMENT PROCEDURES

Hardware and Threaded Parts

Install helical thread inserts when inside threads in castings are stripped, damaged or not capable of withstanding specified torque.

Replace bolts, nuts, studs, washers, spacers and small common hardware if missing or in any way damaged. Clean up or repair minor thread damage with a suitable thread chaser.

Replace all damaged or missing lubrication fittings.

Use Loctite 565 thread sealant on pipe fitting threads.

Threadlocking Agents

Always follow specific service manual procedures when working with fasteners containing preapplied threadlocking agents when fastener replacement is recommended.

When re-using fasteners containing threadlocking agents, be sure to completely remove all existing threadlocking agent from fastener threads with a wire brush or wire wheel. Also, be sure to remove residual threadlocking agent from fastener hole using an appropriate thread chasing device and compressed air when using new or existing fasteners.

Always use the recommended threadlocking agent for your specific procedure.

Wiring, Hoses and Lines

Replace hoses, clamps, electrical wiring, electrical switches or fuel lines if they do not meet specifications.

Instruments and Gauges

Replace broken or defective instruments and gauges.

Bearings

Anti-friction bearings must be handled in a special way. To keep out dirt and abrasives, cover the bearings as soon as they are removed from the package.

Wash bearings in a non-flammable cleaning solution. Knock out packed lubricant inside by tapping the bearing against a wooden block. Wash bearings again. Cover bearings with clean material after setting them down to dry. Never use compressed air to dry bearings.

Coat bearings with clean oil. Wrap bearings in clean paper.

Be sure that the chamfered side of the bearing always faces the shoulder (when bearings installed against shoulders). Lubricate bearings and all metal contact surfaces before pressing into place. Only apply pressure on the part of the bearing that makes direct contact with the mating part. Install bearings with numbered side facing out.

Always use the proper tools and fixtures for removing and installing bearings.

Bearings do not usually need to be removed. Only remove bearings if necessary.

Bushings

Do not remove a bushing unless damaged, excessively worn or loose in its bore. Press out bushings that must be replaced.

When pressing or driving bushings, be sure to apply pressure in line with the bushing bore. Use a bearing/bushing driver or a bar with a smooth, flat end. Never use a hammer to drive bushings.

Inspect the bushing and the mated part for oil holes. Be sure all oil holes are properly aligned.

Gaskets

Always discard gaskets after removal. Replace with **new** gaskets. Never use the same gasket twice. Be sure that gasket holes match up with holes in the mating part.

Lip Type Seals

Lip seals are used to seal oil or grease and are usually installed with the sealing lip facing the contained lubricant. Seal orientation, however, may vary under different applications.

Seals should not be removed unless necessary. Only remove seals if required to gain access to other parts or if seal damage or wear dictates replacement.

Leaking oil or grease usually means that a seal is damaged. Replace leaking seals to prevent overheated bearings.

Always discard seals after removal. Do not use the same seal twice.

O-Rings (Preformed Packings)

Always discard O-rings after removal. Replace with **new** O-rings. To prevent leaks, lubricate the O-rings before installation. Apply the same type of lubricant as that being sealed. Be sure that all gasket, O-ring and seal mating surfaces are thoroughly clean before installation.

Gears

Always check gears for damaged or worn teeth.

Lubricate mating surfaces before pressing gears on shafts.

Shafts

If a shaft does not come out easily, check that all nuts, bolts or retaining rings have been removed. Check to see if other parts are in the way before using force.

Shafts fitted to tapered splines should be very tight. If shafts are not tight, disassemble and inspect tapered splines. Discard parts that are worn. Be sure tapered splines are clean, dry and free of burrs before putting them in place. Press mating parts together tightly.

Clean all rust from the machined surfaces of new parts.

Part Replacement

Always replace worn or damaged parts with **new** parts.

CLEANING

Part Protection

Before cleaning, protect rubber parts (such as hoses, boots and electrical insulation) from cleaning solutions. Use a grease-proof barrier material. Remove the rubber part if it cannot be properly protected.

Cleaning Process

Any cleaning method may be used as long as it does not result in parts damage. Thorough cleaning is necessary for proper parts inspection. Strip rusted paint areas to bare metal before repainting.

Rust or Corrosion Removal

Remove rust and corrosion with a wire brush, abrasive cloth, sand blasting, vapor blasting or rust remover. Use buffing crocus cloth on highly polished parts that are rusted.

TOOL SAFETY

Air Tools

- Always use approved eye protection equipment when performing any task using air-operated tools.
- On all power tools, use only recommended accessories with proper capacity ratings.
- Do not exceed air pressure ratings of any power tools.
- Bits should be placed against work surface before air hammers are operated.
- Disconnect the air supply line to an air hammer before attaching a bit.
- Never point an air tool at yourself or another person.
- Protect bystanders with approved eye protection.

Wrenches

- Never use an extension on a wrench handle.
- If possible, always pull on a wrench handle and adjust your stance to prevent a fall if something lets go.
- Never cock a wrench.
- Never use a hammer on any wrench other than a STRIKING FACE wrench.
- Discard any wrench with broken or battered points.
- Never use a pipe wrench to bend, raise or lift a pipe.

Pliers/cutters/pry bars

- Plastic- or vinyl-covered pliers handles are not intended to act as insulation; don't use on live electrical circuits.
- Don't use pliers or cutters for cutting hardened wire unless they were designed for that purpose.
- Always cut at right angles.
- Don't use any pry bar as a chisel, punch or hammer.

Hammers

- Never strike one hammer against a hardened object, such as another hammer.
- Always grasp a hammer handle firmly, close to the end.
- Strike the object with the full face of the hammer.
- Never work with a hammer which has a loose head.
- Discard hammer if face is chipped or mushroomed.
- Wear approved eye protection when using striking tools.
- Protect bystanders with approved eye protection.

Punches/chisels

- Never use a punch or chisel with a chipped or mushroomed end; dress mushroomed chisels and punches with a file.
- Hold a chisel or a punch with a tool holder if possible.
- When using a chisel on a small piece, clamp the piece firmly in a vise and chip toward the stationary jaw.
- Wear approved eye protection when using these tools.
- Protect bystanders with approved eye protection.

Screwdrivers

- Don't use a screwdriver for prying, punching, chiseling, scoring or scraping.
- Use the right type of screwdriver for the job; match the tip to the fastener.
- Don't interchange POZIDRIV[®], PHILLIPS[®] or REED AND PRINCE screwdrivers.
- Screwdriver handles are not intended to act as insulation; don't use on live electrical circuits.
- Don't use a screwdriver with rounded edges because it will slip – redress with a file.

Ratchets and Handles

- Periodically clean and lubricate ratchet mechanisms with a light grade oil. Do not replace parts individually; ratchets should be rebuilt with the entire contents of service kit.
- Never hammer or put a pipe extension on a ratchet or handle for added leverage.
- Always support the ratchet head when using socket extensions, but do not put your hand on the head or you may interfere with the action of its reversing mechanism.
- When breaking loose a fastener, apply a small amount of pressure as a test to be sure the ratchet's gear wheel is engaged with the pawl.

Sockets

- Never use hand sockets on power or impact wrenches.
- Select the right size socket for the job.
- Never cock any wrench or socket.
- Select only impact sockets for use with air or electric impact wrenches.
- Replace sockets showing cracks or wear.
- Keep sockets clean.
- Always use approved eye protection when using power or impact sockets.

Storage Units

- Don't open more than one loaded drawer at a time. Close each drawer before opening up another.
- Close lids and lock drawers and doors before moving storage units.
- Don't pull on a tool cabinet; push it in front of you.
- Set the brakes on the locking casters after the cabinet has been rolled to your work.

BRAKE FLUID

 **WARNING**

Direct contact of D.O.T. 4 brake fluid with eyes can cause irritation. Avoid eye contact. In case of eye contact flush with large amounts of water and get medical attention. Swallowing large amounts of D.O.T. 4 brake fluid can cause digestive discomfort. If swallowed, obtain medical attention. Use in well ventilated area. KEEP OUT OF REACH OF CHILDREN. (00240a)

Use only D.O.T. 4 BRAKE FLUID (Part No. 99953-99A).

FRONT FORK OIL

Use only TYPE E FORK OIL (Part No. HD-99884-80).

ENGINE OIL

Use the proper grade of oil for the lowest temperature expected before the next oil change.

If it is necessary to add oil and Harley-Davidson oil is not available, use an oil certified for diesel engines. Acceptable diesel engine oil designations include CF-4, CG-4, CH-4 and CI-4. The preferred viscosities for the diesel engine oils, in descending order, are 20W-50, 15W-40 and 10W-40. At the first opportunity, see a Buell dealer to change back to 100 percent Harley-Davidson oil.

PRIMARY DRIVE/TRANSMISSION FLUID

Use only Genuine Harley-Davidson FORMULA+ TRANSMISSION AND PRIMARY CHAINCASE LUBRICANT (Part No. 99851-05).

Table 1-1. Regular Service Intervals For Buell Blast Models

ITEM SERVICED	PROCEDURE	1 0 0 0 mi	2 5 0 0 mi	5 0 0 0 mi	7 5 0 0 mi	1 0 0 0 0 mi	1 2 5 0 0 mi	1 5 0 0 0 mi	1 7 5 0 0 mi	2 0 0 0 0 mi	2 2 5 0 0 mi	2 5 0 0 0 mi	NOTES
		1 6 0 0 0 km	4 0 0 0 0 km	8 0 0 0 0 km	1 2 0 0 0 0 km	1 6 0 0 0 0 km	2 0 0 0 0 0 km	2 4 0 0 0 0 km	2 8 0 0 0 0 km	3 2 0 0 0 0 km	3 6 0 0 0 0 km	4 0 0 0 0 0 km	
Engine oil and filter	Replace	X		X		X		X		X		X	
	Inspect		X		X		X		X		X		
Oil lines and brake system	Inspect for leaks	X	X	X	X	X	X	X	X	X	X	X	1
Air cleaner	Inspect, service as required					X				X			
Crankcase breather hose	Drain	X		X		X		X		X		X	
Tires	Check pressure, inspect tread	X	X	X	X	X	X	X	X	X	X	X	
Transmission lubricant	Replace	X				X				X			1
Clutch	Check adjustment	X		X		X		X		X		X	1
Primary chain	Check adjustment	X	X	X	X	X	X	X	X	X	X	X	1
Rear belt and rear sprocket	Replace							X					1
Throttle control	Check operation	X	X	X	X	X	X	X	X	X	X	X	1
Throttle, brake and clutch controls, jiffy stand	Lubricate			X		X		X		X		X	1
Fuel valve, lines and fittings	Inspect for leaks	X	X	X	X	X	X	X	X	X	X	X	1
Fuel tank filter screen	Clean									X			1
Brake fluid	Check levels and condition	X		X		X		X		X		X	3
Brake pads and discs	Inspect for wear	X	X	X	X	X	X	X	X	X	X	X	
Rear brake pads and rear brake pins	Replace							X					1
Rear brake pedal	Check operation	X		X		X		X		X		X	1
Spark plug	Replace					X				X			
Electrical equipment and switches, starter interlock	Check operation	X	X	X	X	X	X	X	X	X	X	X	
Engine idle speed	Check adjustment	X	X	X	X	X	X	X	X	X	X	X	1
Ignition timing	Check					X				X			1
Front fork oil	Replace									X			1
Steering head bearings	Lubricate and adjust									X			1
Rear shock absorber	Check					X				X			
Wheel bearings	Inspect												2
Exhaust system hardware including muffler strap	Inspect					X				X			1
Critical fasteners	Check tightness					X				X			1
Engine mounts and stabilizer links	Inspect					X				X			1
Battery	Check battery and clean connections	X	X	X	X	X	X	X	X	X	X	X	
Road test	Verify component and system functions	X	X	X	X	X	X	X	X	X	X	X	

NOTES:

- Should be performed by an authorized Harley-Davidson dealer, unless you have the proper tools, service data and are mechanically qualified.
- Inspect wheel bearings whenever wheel is removed (tire change, fork fluid change, etc.)
- Change brake fluid every two (2) years.

Table 1-2. Quick Reference Maintenance Chart

ITEM SERVICED	SPECIFICATION	DATA
Engine oil and filter	Type	See 1.2 FLUID REQUIREMENTS
	Drain plug torque	Plug with spring clamp.
	Oil capacity	2.0 qt. (1.89 L) Until oil registers between marks on dipstick.
	Filter	Hand tighten 1/2-3/4 turn after gasket contact.
	Black filter part number	63806-00Y
Primary chain tension	Deflection with hot engine	NONE
	Deflection with cold engine	Tighten chain limiting screw to 24 in-lbs (2.7 Nm) Back-off chain limiting screw 3/4 turn (4 1/2 "flats").
	Chain tensioner nut torque	Hold chain limiting screw while tightening jam nut. Tighten to 20-25 ft-lbs (28-33 Nm).
	Primary chain inspection cover torque	N/A
Clutch adjustment	Free play at adjuster screw	1/4 - 1/2 turn
	Free play at hand lever	0.0625-0.125 in. (1.6-3.2 mm)
	Clutch inspection cover torque	84-108 in-lbs (9.5-12.2 Nm)
Primary chain/transmission lubricant	Type	FORMULA+ TRANSMISSION AND PRIMARY CHAINCASE LUBRICANT (Part No. 99851-05)
	Lubricant level	Inspect fluid level with motorcycle in upright position. Level with bottom of clutch shell.
	Lubricant capacity	32 oz. (946 mL)
	Transmission drain plug torque	14-30 ft-lbs (19-40.7 Nm)
Tire condition and pressure	Pressure for solo rider	Front: 28 psi (1.9 bar) Rear: 30 psi (2.1 bar)
	Pressure for rider and passenger	Front: 32 psi (2.2 bar) Rear: 36 psi (2.5 bar)
	Wear	Replace tire if 1/32 in. (0.8 mm) or less of tread pattern remains.
Brake fluid reservoir level	Type	D.O.T. 4 BRAKE FLUID (Part No. 99953-99A)
	Proper fluid level	Front: 1/8 in. (3.2 mm) from the top Rear: Between upper and lower marks
	Front master cylinder reservoir cover torque	9-13 in-lbs (1.0-1.5 Nm)
Brake pad linings and discs	Minimum brake pad thickness	0.1 in. (2.5 mm) or less
	Minimum brake disc thickness	0.180 in. (4.5 mm)
Drive belt	Upward measurement force applied at midpoint of bottom belt strand	10 lb. (4.5 kg)
	Belt deflection with motorcycle on jiffy stand and a 160 lb. rider or equivalent weight sitting on the motorcycle.	Maximum allowable deflection is 0.5 in. (12.7 mm) at the bottom strand.

Table 1-2. Quick Reference Maintenance Chart

ITEM SERVICED	SPECIFICATION	DATA
Air cleaner	Air cleaner cover bracket screw torque	36-60 in-lbs (4.1-6.8 Nm)
	Air cleaner cover screw torque	4-6 in-lbs (0.5-0.7 Nm)
	Adhesive for air cleaner bracket screws	Loctite Threadlocker 222 (purple) Part No. 99811-97 (6 ml)
Fuel valve fasteners	Two allen head screws torque	18-21 in-lbs (2.1-2.3 Nm)
Enrichener control	Phillips screw (with lock washer)	13-23 in-lbs (2-3 Nm)
Clutch and throttle cables	Lubricant	SUPER OIL Part No. 94968-85TV (1/4 fl. oz.)
	Handlebar clamp screw torque	120-144 in-lbs (14-16 Nm)
	Handlebar switch housing screw torque	25-33 in-lbs (3-4 Nm)
Spark plugs	Type	10R12A
	Gap	0.035 in. (0.9 mm)
	Torque	12-18 ft-lbs (16-24.4 Nm)
Engine idle speed	Idle speed	1200 RPM
Front fork oil	Type	HYDRAULIC FORK OIL (TYPE E) Part No. 99884-80 {9.2 oz. (272.1 ml)}
Battery	Lubricant	ELECTRICAL CONTACT LUBRICANT Part No. 99861-02 (1 oz.)
	Battery terminal torque	72-96 in-lbs (8-11 Nm)

DISCONNECTION AND REMOVAL

1. Remove seat. See 2.28 SEAT.

⚠ WARNING

To prevent accidental vehicle start-up, which could cause death or serious injury, disconnect negative (-) battery cable before proceeding. (00048a)

⚠ WARNING

Disconnect negative (-) battery cable first. If positive (+) cable should contact ground with negative (-) cable connected, the resulting sparks can cause a battery explosion, which could result in death or serious injury. (00049a)

2. Unthread bolt and remove battery negative cable (black) from battery negative (-) terminal.
3. Unthread bolt and remove battery positive cable (red) from battery positive (+) terminal.
4. Remove battery from motorcycle.

INSTALLATION AND CONNECTION

1. Place the fully charged battery on the battery pad, terminal side facing up.

CAUTION

Connect the cables to the correct battery terminals. Failure to do so could result in damage to the motorcycle electrical system. (00215a)

⚠ WARNING

Connect positive (+) battery cable first. If positive (+) cable should contact ground with negative (-) cable connected, the resulting sparks can cause a battery explosion, which could result in death or serious injury. (00068a)

CAUTION

Do not over-tighten bolts on battery terminals. Use recommended torque values. Over-tightening battery terminal bolts could result in damage to battery terminals. (00216a)

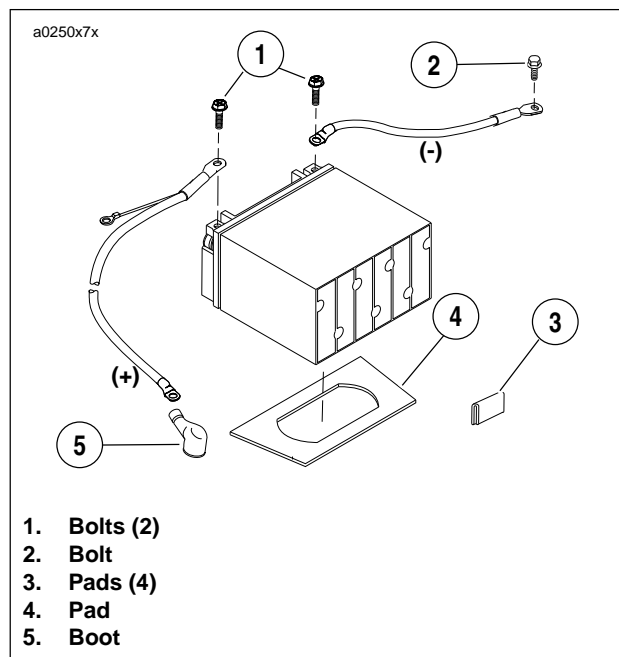


Figure 1-1. Battery Installation

2. See Figure 1-1. Insert bolt through battery positive cable (red) into threaded hole of battery positive (+) terminal. Tighten bolt to 72-96 in-lbs (8-11 Nm).
3. See Figure 1-1. Insert bolt through battery negative cable (black) into threaded hole of battery negative (-) terminal. Tighten bolt to 72-96 in-lbs (8-11 Nm).
4. Apply a light coat of petroleum jelly or corrosion retardant material to both battery terminals.

⚠ WARNING

After installing seat, pull upward on front of seat to be sure it is in locked position. While riding, a loose seat can shift causing loss of control, which could result in death or serious injury. (00070a)

5. Install seat. See 2.28 SEAT.

GENERAL

Check engine oil level (hot check):

- At every stop for fuel.

Inspect oil lines and filter for leaks:

Change engine oil and filter (and drain crankcase breather hose) under normal service in warm or moderate temperatures: See [1.3 MAINTENANCE SCHEDULE](#).

Change engine oil and filter (and drain crankcase breather hose) under severe service in warm or moderate temperatures (severe dust, temperatures above 80° F/27° C, extensive idling or speeds in excess of 65 m.p.h./105 km/h, extensive two-up riding):

NOTE

Shorten oil change interval in cold weather.

Table 1-3. Recommended Engine Oils

Harley-Davidson Type	Viscosity	Harley-Davidson Rating	Lowest Ambient Temperature	Cold Weather Starts Below 50° F (10° C)
HD Multi-grade	SAE 10W40	HD 360	Below 40° F (4° C)	Excellent
HD Multi-grade	SAE 20W50	HD 360	Above 40° F (4° C)	Good
HD Regular Heavy	SAE 50	HD 360	Above 60° F (16° C)	Poor
HD Extra Heavy	SAE 60	HD 360	Above 80° F (27° C)	Poor

CHECKING ENGINE OIL LEVEL

An accurate engine oil level reading can *only* be obtained after the engine has reached normal operating temperature (Hot Check). The engine will require a longer warm up period in colder weather.

For pre-ride inspection, simply verify that there are no oil leaks from the oil filter and oil lines prior to operating the motorcycle.

- Perform a hot check of the engine oil level at each fuel stop.

Hot Check

CAUTION

Do NOT operate the engine when the oil level is below the add mark on the dipstick at operating temperature. Engine damage will result. (00187a)

CAUTION

Do not overfill oil tank. Doing so can result in oil carry-over to the air cleaner leading to equipment damage and/or equipment malfunction. (00190a)

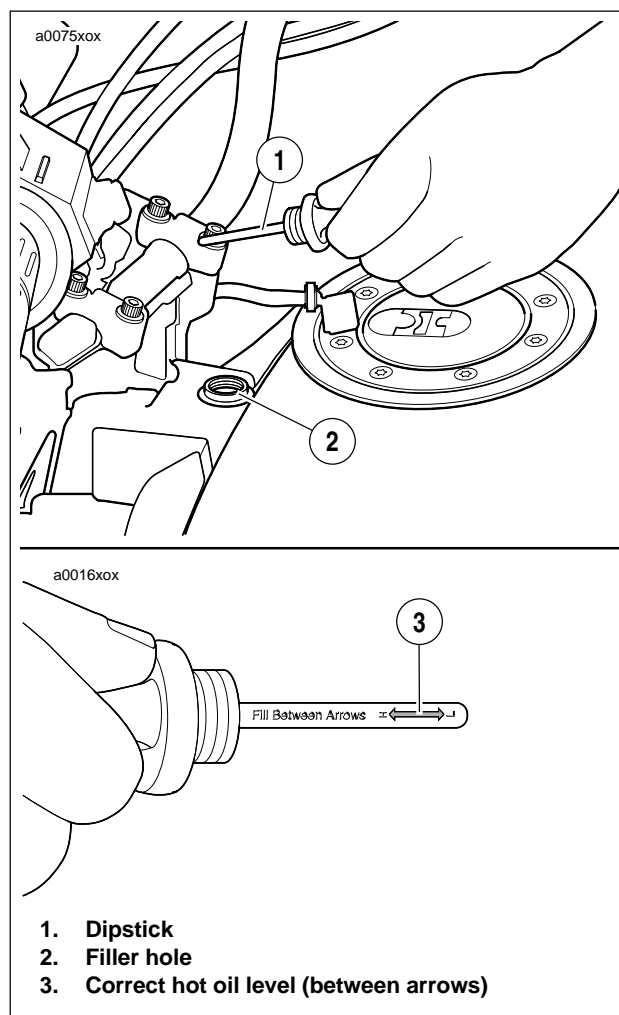
CAUTION

Do not switch lubricant brands indiscriminately because some lubricants interact chemically when mixed. Use of inferior lubricants can damage the engine. (00184a)

The motorcycle should be ridden for approximately 10 minutes to ensure oil is hot and engine is at normal operating temperature.

1. The motorcycle must be in upright position and level (not on sidestand) with the engine OFF.
2. See Figure 1-2. Unscrew dipstick from frame filler hole.
3. Wipe off dipstick and insert into frame filler hole, screwing dipstick completely into filler neck.
4. See Figure 1-2. Remove dipstick and note oil level.

Hot oil level should be between the upper and lower “fill” marks on dipstick. If oil level is down to or below lower “fill” mark on dipstick, add only enough oil to bring level between lower and upper “fill” marks.



1. Dipstick
2. Filler hole
3. Correct hot oil level (between arrows)

Figure 1-2. Dipstick Location/Engine Oil Level

CHANGING ENGINE OIL AND FILTER

CAUTION

Do not switch lubricant brands indiscriminately because some lubricants interact chemically when mixed. Use of inferior lubricants can damage the engine. (00184a)

1. See Figure 1-3. Locate the engine oil tank drain hose (normally the lower hose) and the crankcase breather drain hose (normally the upper hose) inside the foot peg support frame on the left side of the motorcycle.
2. Remove fastener from hose retention clamp.
3. Place a drain pan directly underneath the engine oil drain hose.
4. Loosen the spring clamp and remove engine oil drain drain plug from drain hose.
5. Allow used oil to drain completely.
6. Loosen spring clamp and remove crankcase breather hose drain plug to allow any oil present to drain.
7. See Figure 1-4. Remove the oil filter (located at the front of the engine).
8. Clean filter gasket contact surface on mounting plate (surface should be smooth and free of any debris, used oil or old gasket material).
9. See Figure 1-4. Apply a thin film of clean oil to gasket on new oil filter.
10. Install **new** oil filter (Part No. 63806-00Y) onto adapter until gasket contacts plate surface, then tighten another 1/2-3/4 turn. Do not overtighten.
11. Place two drain hoses back on the hose fixture. Install drain plugs to drain hoses and secure plugs with spring clamps.
12. See Figure 1-2. Remove dipstick and refill with approximately 1.5 qt (1,419.5 ml) recommended oil at filler hole. Refer to Table 1-3.
13. Install dipstick and operate motorcycle for 10 minutes to reach normal operating temperature. Check oil level again (hot check) and add oil as necessary until oil registers between marks on dipstick.

WARNING

Check that no lubricant gets on tires, wheels or brakes when changing fluid. Traction can be adversely affected, which could result in loss of control of the motorcycle and death or serious injury. (00047b)

- Change oil more frequently if bike is operated under severe conditions (dusty, very hot or cold temperatures).
- Drain oil after operating motorcycle (while oil is still very warm).
- Replace oil filter every time the oil is changed.
- Drain the crankcase breather drain hose of any accumulated oil every time the oil is changed.

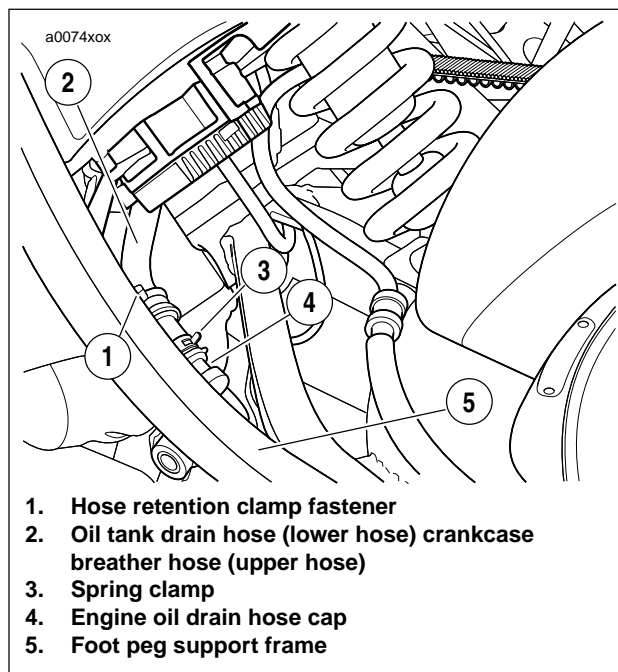


Figure 1-3. Oil Tank Drain Hose

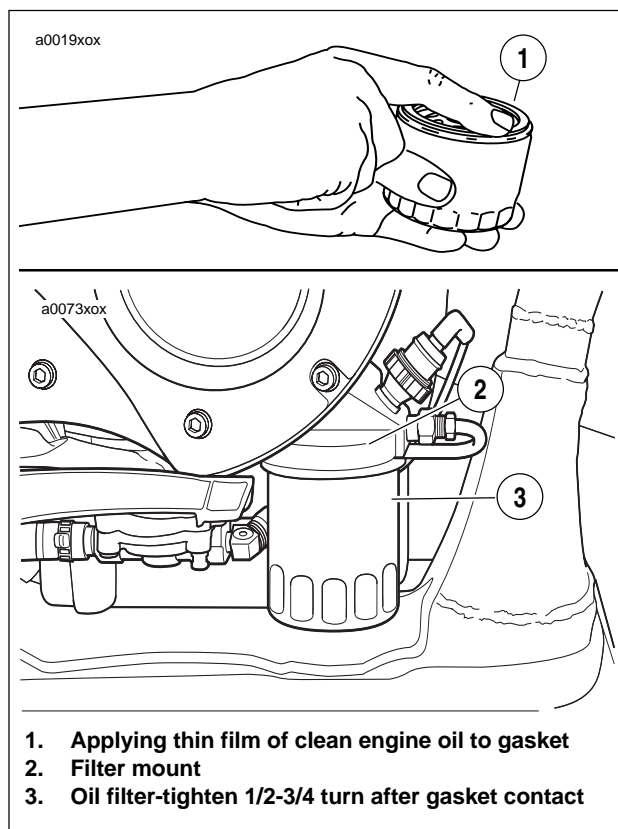


Figure 1-4. Installing New Oil Filter

GENERAL

Check the master cylinder reservoirs for proper fluid levels after the first 1000 miles (1600 km) and every 5000 miles (8000 km) thereafter. Also inspect fluid levels at the end of every riding season.

Check brake pads and rotors for wear at every service interval. See [1.7 BRAKE PADS AND ROTORS](#).

Replace **D.O.T. 4 BRAKE FLUID**:

- Every 2 years.

It is recommended to inspect both front and rear brake lines and replace as required:

- Every 4 years.

It is recommended to inspect both front and rear caliper and master cylinder seals and replace as required:

- Every 2 years.

Check rear brake pedal operation:

- Before every ride.

Lubricate the front brake hand lever:

FLUID LEVEL

See [Figure 1-5](#). With motorcycle in a level position, check that brake fluid is between the upper and lower marks on front and rear reservoirs. Add **D.O.T. 4 BRAKE FLUID** if necessary. Be sure gasket and cap on reservoir fit securely.

BLEEDING BRAKES

WARNING

Direct contact of D.O.T. 4 brake fluid with eyes can cause irritation. Avoid eye contact. In case of eye contact flush with large amounts of water and get medical attention. Swallowing large amounts of D.O.T. 4 brake fluid can cause digestive discomfort. If swallowed, obtain medical attention. Use in well ventilated area. **KEEP OUT OF REACH OF CHILDREN.** (00240a)



Figure 1-5. Rear Brake Fluid Reservoir



Figure 1-6. Front Brake Caliper Bleeder Valve



Figure 1-7. Rear Brake Caliper Bleeder Valve (Metric)

WARNING

Never mix D.O.T. 4 with other brake fluids (such as D.O.T. 5). Use only D.O.T. 4 brake fluid in motorcycles that specify D.O.T. 4 fluid on the reservoir cap. Mixing different types of fluid can adversely affect braking ability and lead to brake failure which could result in death or serious injury

WARNING

Use only fresh, uncontaminated D.O.T. 4 Fluid. Cans of fluid that have been opened may have been contaminated by moisture in the air or dirt. Use of contaminated brake fluid can adversely affect braking ability and lead to brake failure which could result in death or serious injury

WARNING

Use only new copper banjo washers (See Parts Catalog for Part No.) with D.O.T. 4 brake fluid. Earlier silver banjo washers are not compatible with D.O.T. 4 fluid and will not seal properly over time. Failure to comply can adversely affect braking ability and lead to brake failure which could result in death or serious injury.

NOTE

Hydraulic brake fluid bladder-type pressure equipment can be used to fill the brake master cylinder through the bleeder valve if master cylinder reservoir cover is removed to prevent pressurization.

1. Install end of a length of plastic tubing over caliper bleeder valve; place other end in a clean container. Stand motorcycle upright.
 - a. See [Figure 1-6](#). Front brake bleeder valve.
 - b. See [Figure 1-7](#). Rear brake bleeder valve.

IMPORTANT NOTE

Cover molded-in-color surfaces and right handlebar switches and use care when removing brake reservoir cover and adding D.O.T. 4 brake fluid. Spilling D.O.T. 4 brake fluid on molded-in-color surfaces will result in cosmetic damage. Spilling brake fluid on switches can render them inoperative.

2. Add **D.O.T. 4 BRAKE FLUID** to master cylinder reservoir. Do not reuse brake fluid.
 - a. Remove two screws from front master cylinder cover. Bring fluid level to within 0.125 in. (3.2 mm) of molded boss inside front master cylinder.
 - b. Remove cap and gasket from rear master cylinder reservoir. Bring fluid level to between upper and lower marks on reservoir.
3. Depress, release and then hold brake lever/pedal to build up hydraulic pressure.
4. Open bleeder valve (metric) about 1/2-turn counterclockwise; brake fluid will flow from bleeder valve and through tubing. When brake lever/pedal has moved 1/2-3/4 of its full range of travel, close bleeder valve (clockwise). Allow brake lever/pedal to return slowly to its released position.
5. Repeat Steps 2-4 until all air bubbles are purged.

6. Tighten bleeder valve (metric) to 36-60 **in-lbs** (4.1-6.8 Nm).
7. Verify master cylinder fluid level as described in Step 2.

WARNING

After repairing the brake system, test brakes at low speed. If brakes are not operating properly, testing at high speeds can cause loss of control, which could result in death or serious injury. (00289a)

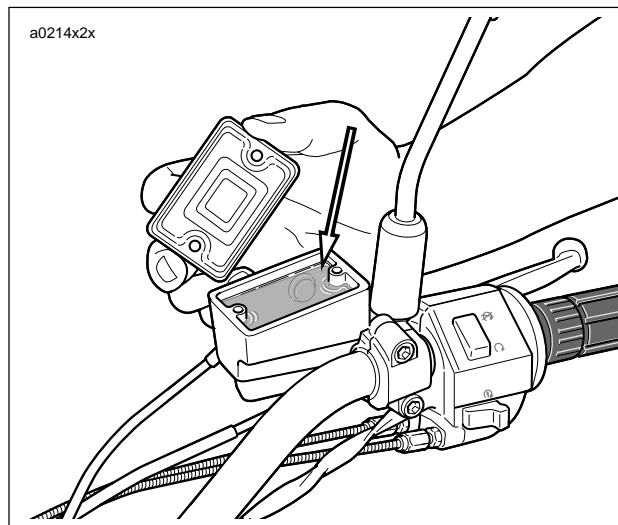


Figure 1-8. Brake Fluid Level - Front Reservoir

8. Attach covers to master cylinder reservoirs.
 - a. Tighten screws on master cylinder reservoir cover to 9-13 **in-lbs** (1.0-1.5 Nm).
 - b. Tighten cap on rear master cylinder securely.

REAR BRAKE PEDAL**WARNING**

After repairing the brake system, test brakes at low speed. If brakes are not operating properly, testing at high speeds can cause loss of control, which could result in death or serious injury. (00289a)

Check rear brake pedal for proper operation.

- Before every ride.
1. Inspect locknut installation. Locknut should be flush with top surface of clevis.
 2. Observe the position of brake pedal and foot peg. Brake pedal should be set so top surface of brake pedal is even with top surface of foot peg.
 3. Set brake pedal height.
 - a. Loosen locknut.
 - b. Turn rod adjuster to obtain correct position.
 - c. Tighten locknut.

NOTE

Brake pedal has no freeplay adjustment.

BRAKE PADS

WARNING

Always replace brake pads in complete sets for correct and safe brake operation. Improper brake operation could result in death or serious injury. (00111a)

See Figure 1-9. Inspect brake pads for damage or excessive wear. Replace both pads as a set if friction material of either pad is worn to 0.1 in. (2.5 mm) or less. If this amount of wear occurs, wear grooves (2) will disappear from friction material surface. See Figure 1-10.

NOTE

Always replace brake pads in pairs.

BRAKE ROTORS

WARNING

Be sure that brake fluid or other lubricants do not contact brake pads or discs. Such contact can adversely affect braking ability, which could cause loss of control, resulting in death or serious injury. (00290a)

Check front and rear brake rotors for minimum thickness:

1. Measure rotor thickness. Replace if minimum thickness is less than 0.18 in. (4.5 mm).
2. Check rotor surface. Replace if warped or badly scored.
3. The brake rotor must be within the following specifications. If the brake rotor is suspected of being damaged, inspect rotor using the following measurements:
 - Lateral Movement: 0.01-0.02 in. (0.3-0.5 mm).
 - Radial Movement: 0.02 in. (0.5 mm).
 - Rotational Movement: 0.02 in. (0.5 mm).

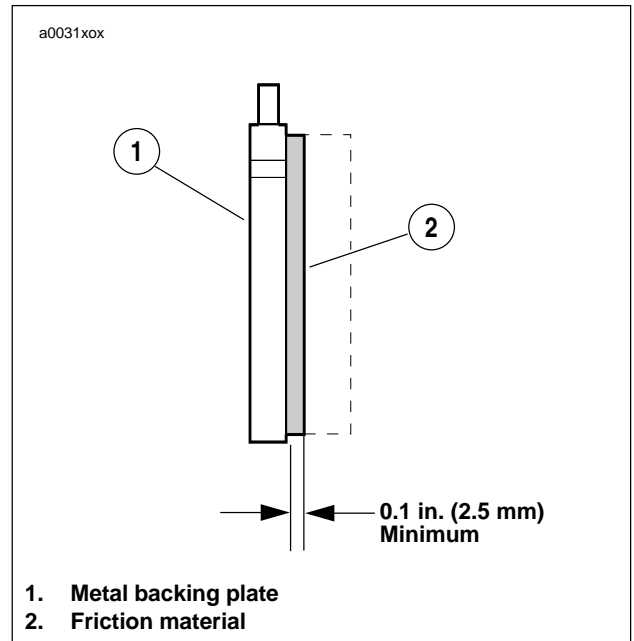


Figure 1-9. Brake Pad - Side View

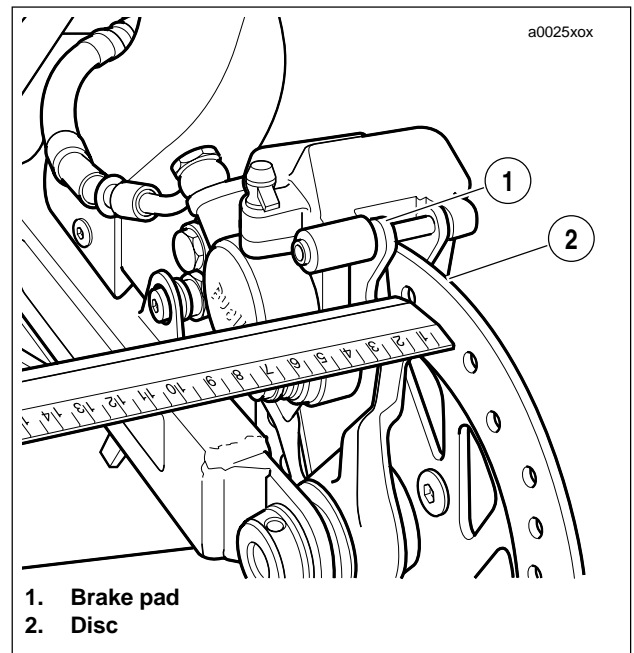


Figure 1-10. Measuring Rear Brake Outer Pad

TIRE INFLATION

⚠ WARNING

Do not inflate tire beyond maximum pressure as specified on sidewall. Over inflated tires can blow out, which could result in death or serious injury. (00027a)

Check tire pressure and tread:

- Before every ride.

Check for proper front and rear tire pressures when tires are cold. Compare pressure against [Table 1-4](#).

Table 1-4. Tire Specifications/Pressures

P3 Tires	SOLO RIDING	LOADED TO GVWR
Front Dunlop 100/80 16 50s K330	28 psi (193 kPa)	32 psi (220 kPa)
Rear Dunlop 120/80 16 60s K330	30 psi (207 kPa)	36 psi (248 kPa)

WHEEL BEARINGS

The wheel bearings are sealed units, no greasing or maintenance is required. Replace when worn. Excessive play or roughness indicates worn bearings that require replacement.

Check front and rear wheel bearings for wear:

- Every time a wheel is removed.
- When storing for the season or removing the motorcycle from storage.

Check wheel bearings for wear and corrosion. Excessive play or roughness indicates worn bearings. Replace bearings in sets only.

TIRE TREAD INSPECTION

See [Figure 1-11](#). Tread wear indicator bars (2) will appear on tire tread surfaces when 1/32 inch (0.79 mm) or less of tire tread remains. Arrows (1) on tire sidewalls pinpoint location of wear bar indicators. Always remove tires from service before they reach the tread wear indicator bars (1/32 of an inch [(0.79 mm)] tread pattern depth remaining).

New tires are needed if any of the following conditions exist.

1. Tread wear indicator bars become visible on the tread surfaces.
2. Tire cords or fabric become visible through cracked sidewalls, snags or deep cuts.
3. A bump, bulge or split in the tire.
4. Puncture, cut or other damage to the tire that cannot be repaired.

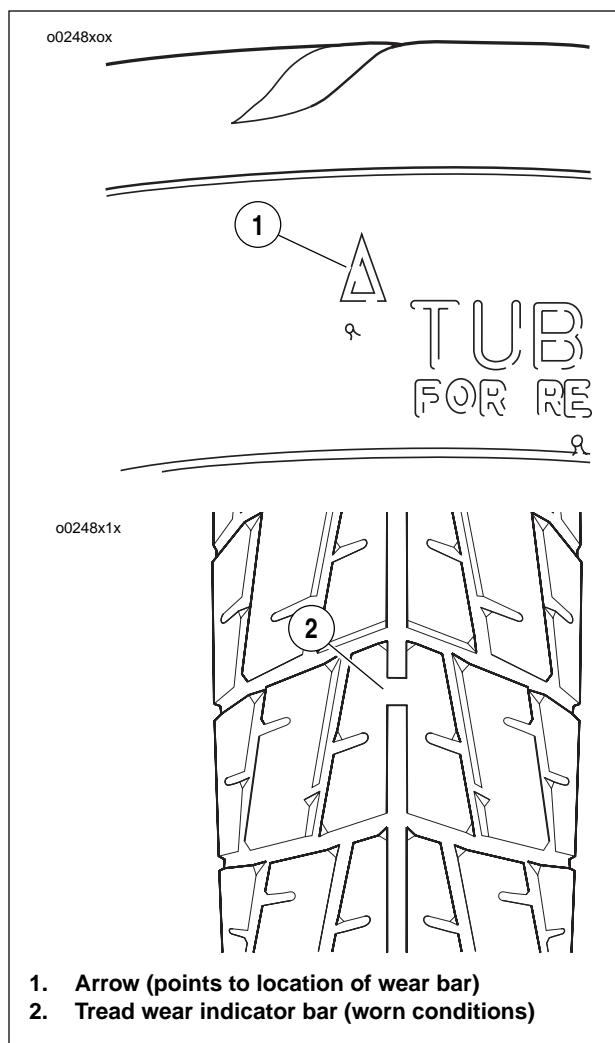


Figure 1-11. Tread Wear Indicators

ADJUSTMENT

Clutch control cable adjustment is required at this interval to compensate for normal clutch lining wear. If the clutch slips under load, or drags when released, adjust the clutch control cable.

1. Raise rear wheel off floor using REAR WHEEL SUPPORT STAND (Part No. B-41174).
2. Remove left footpeg support bracket. See 2.21 FOOTPEGS AND FOOTPEG SUPPORT BRACKETS.

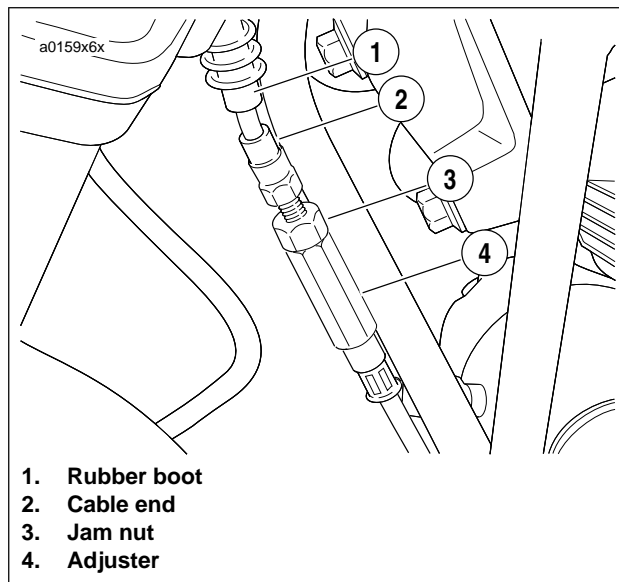


Figure 1-12. Clutch Cable Adjuster Mechanism

3. See Figure 1-12. Slide rubber boot (1) upward to expose adjuster mechanism. Loosen jam nut (3) from adjuster (4). Turn adjuster to shorten cable housing until there is a large amount of freeplay at clutch hand lever.

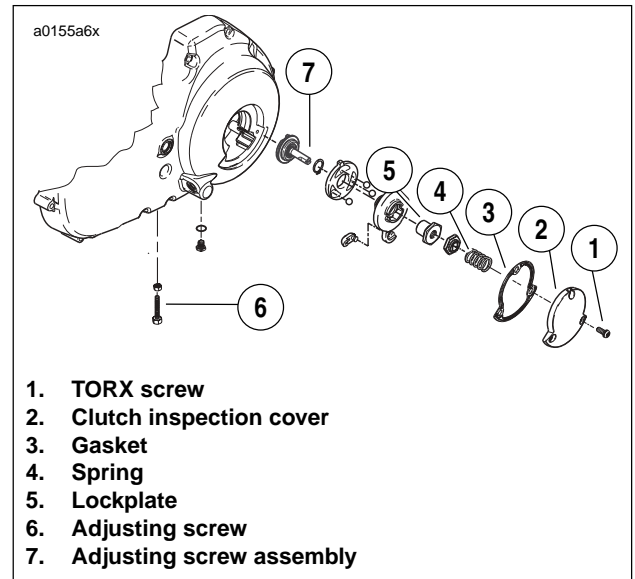


Figure 1-13. Clutch Release Mechanism

4. See Figure 1-13. Remove three TORX screws with washers (1) from clutch inspection cover (2). Remove clutch inspection cover from primary cover.
5. Remove spring (4) and lockplate (5). Turn adjusting screw (6) counterclockwise until it lightly bottoms.
6. Turn adjusting screw (6) clockwise 1/4 - 1/2 turn. Install lockplate (5) and spring (4) on adjusting screw flats. If hex on lockplate does not align with recess in outer ramp, rotate adjusting screw clockwise until it aligns.
7. Squeeze clutch hand lever to maximum limit three times. This sets the ball and ramp mechanism. Pull outer cable conduit and at the same time adjust cable adjuster to provide 0.0625-0.125 in. (1.6-3.2 mm) freeplay at clutch hand lever.

8. Adjust as follows:
 - a. See [Figure 1-14](#). Pull ferrule (end of cable housing) away from bracket. Gap between ferrule and bracket should be 0.0625-0.125 in. (1.6-3.2 mm).
 - b. See [Figure 1-12](#). Set freeplay by turning adjuster.
 - c. Tighten jam nut against adjuster.
 - d. Slide rubber boot over cable adjuster mechanism.
9. Change or add transmission fluid if necessary.

NOTE

Clean parts before re-assembly and use a new gasket.

10. See [Figure 1-13](#). Install **new** gasket and clutch inspection cover using three TORX screws with washers. Tighten in a crosswise pattern to 84-108 **in-lbs** (9.5-12.2 Nm).
11. Check clutch cable freeplay. See Step 7 above.
12. Install left footpeg support bracket. See [2.21 FOOTPEGS AND FOOTPEG SUPPORT BRACKETS](#).

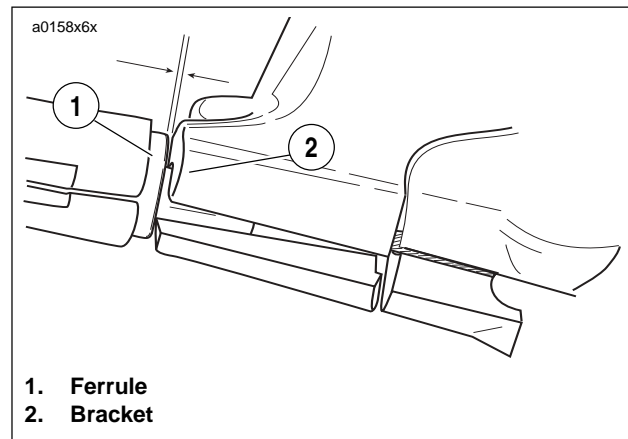


Figure 1-14. Adjusting Clutch Freeplay

GENERAL

Transmission fluid capacity is 1.0 quart (0.95 liter). For best results, drain fluid while it is hot.

INSPECTION

1. Remove seat. See 2.28 SEAT.

⚠ WARNING

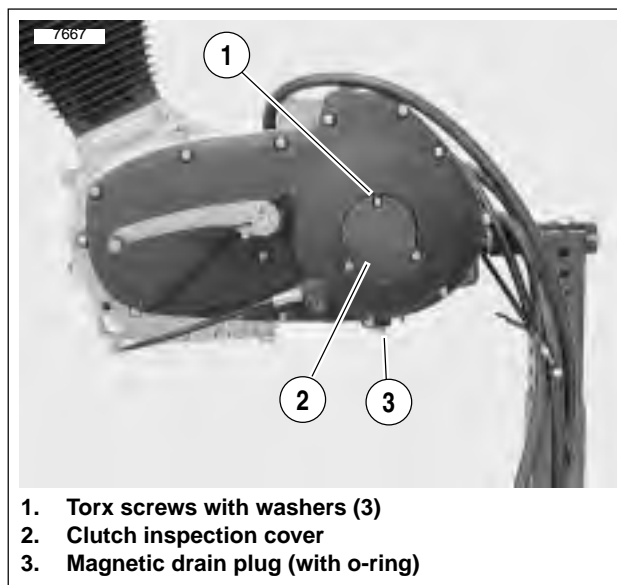
To prevent accidental vehicle start-up, which could cause death or serious injury, disconnect negative (-) battery cable before proceeding. (00048a)

2. Disconnect negative battery cable from battery.
3. Remove left footpeg support bracket. See 2.21 FOOT-PEGS AND FOOTPEG SUPPORT BRACKETS.
4. See Figure 1-15. Remove three TORX screws with washers (1) from clutch inspection cover (2). Remove clutch inspection cover from primary cover.
5. See Figure 1-16. Inspect fluid level with motorcycle in upright position.
6. See Figure 1-15. Install **new** gasket and clutch inspection cover using three TORX screws with washers. Tighten in a crosswise pattern to 84-108 **in-lbs** (9.5-12.2 Nm).
7. Install left footpeg support bracket. See 2.21 FOOT-PEGS AND FOOTPEG SUPPORT BRACKETS.
8. Connect negative battery cable to battery. See 1.4 BATTERY.

⚠ WARNING

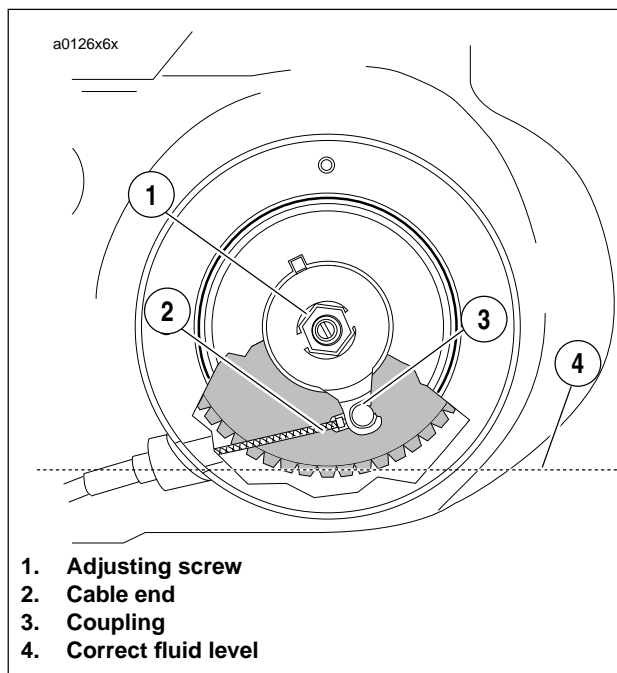
After installing seat, pull upward on front of seat to be sure it is in locked position. While riding, a loose seat can shift causing loss of control, which could result in death or serious injury. (00070a)

9. Install seat. See 2.28 SEAT.



1. Torx screws with washers (3)
2. Clutch inspection cover
3. Magnetic drain plug (with o-ring)

Figure 1-15. Primary Cover



1. Adjusting screw
2. Cable end
3. Coupling
4. Correct fluid level

Figure 1-16. Fluid Level

CHANGING TRANSMISSION FLUID

CAUTION

When draining or adding lubricant, do not allow dirt, debris or other contaminants to enter the engine. (00198a)

1. When the engine reaches normal operating temperature, turn the engine off and position motorcycle on jiffy stand. This will allow the chaincase lubricant to drain out of transmission.
2. See [Figure 1-15](#). Position a suitable container under drain plug (3). Remove magnetic drain plug with O-ring and drain fluid.
3. Position the motorcycle STRAIGHT UP and LEVEL using REAR WHEEL SUPPORT STAND (Part No. B-41174). This allows fluid to be drained from clutch compartment.

NOTE

Dispose of transmission lubricant in accordance with local regulations.

CAUTION

Do not over-tighten drain plug. Doing so could result in a lubricant leak. (00200a)

4. Wipe any foreign material from the magnetic drain plug (3). Inspect O-ring for deterioration and replace as required.
5. Apply Loctite 565 thread sealant to the threads and reinstall drain plug with O-ring. Tighten drain plug to 14-30 ft-lbs (19-40.6 Nm).
6. Remove seat. See [2.28 SEAT](#).

WARNING

To prevent accidental vehicle start-up, which could cause death or serious injury, disconnect negative (-) battery cable before proceeding. (00048a)

7. Disconnect negative battery cable from battery.
8. Remove left footpeg support bracket. See [2.21 FOOTPEGS AND FOOTPEG SUPPORT BRACKETS](#).
9. Remove three TORX screws with washers (1) from clutch inspection cover (2). Remove clutch inspection cover from primary cover.

CAUTION

Do not overfill the primary chaincase with lubricant. Overfilling can cause rough clutch engagement, incomplete disengagement, clutch drag and/or difficulty in finding neutral at engine idle. (00199b)

IMPORTANT NOTE

Make certain primary chaincase is filled with proper amount of lubricant with motorcycle upright. If under filled, transmission can be damaged during vehicle operation.

10. See [Figure 1-16](#). Add FORMULA+ TRANSMISSION AND PRIMARY CHAINCASE LUBRICANT (Part No. 99851-05) as required until fluid level is even with bottom of clutch diaphragm spring.
11. See [Figure 1-15](#). Install clutch inspection cover using three TORX screws with washers. Tighten in a crosswise pattern to 84-108 in-lbs (9.5-12.2 Nm).
12. Install footpeg support bracket. See [2.21 FOOTPEGS AND FOOTPEG SUPPORT BRACKETS](#).
13. Connect negative battery cable to battery. Tighten fastener to 72-96 in-lbs (8-11 Nm).

WARNING

After installing seat, pull upward on front of seat to be sure it is in locked position. While riding, a loose seat can shift causing loss of control, which could result in death or serious injury. (00070a)

14. Install seat. See [2.28 SEAT](#).

GENERAL

Drive belt tension is not adjustable. Replace the belt and sprocket if out of specification.

NOTE

When a drive belt is replaced for any reason other than stone damage, it is recommended that the transmission and rear sprockets also be replaced to increase the longevity of the new drive belt. In the case of stone damage, inspect sprockets for damage and replace as required.

CLEANING

Use only mild soap and water spray solution to clean drive belt. Dry thoroughly. Do not immerse belt in solution.

INSPECTION

Checking Belt Deflection

NOTES:

Vehicle must be at room temperature and dry to obtain a correct measurement.

There are tight and loose spots during rear wheel rotation that affect belt deflection. For a more precise measurement, take three deflection readings, rotating the rear wheel between measurements. Average the three readings for a more precise measurement.

- Deflection should be measured with the rear wheel on the ground and a 160 lb. (72.57 Kg) rider or equivalent weight sitting on the motorcycle.
- Maximum allowable deflection (measured with 10 lbs./4.5 kg. of force) is 0.5 in. (12.7 mm) at the bottom strand.

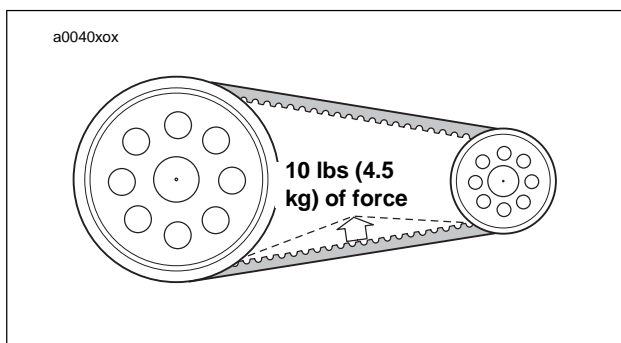


Figure 1-17. Measuring Belt Deflection

See Figure 1-17. Using BELT TENSION GAUGE (Part No. HD-35381), apply 10 lbs (4.5 kg) of force at the midpoint of the belt's appropriate strand. The maximum allowable deflection is 0.5 in. (12.7 mm) at the bottom strand.

- Replace belt and drive sprocket that exceed maximum allowable deflection.

WARNING

Be sure wheel and brake caliper are aligned. Riding with a misaligned wheel or brake caliper can cause the brake disc to bind and lead to loss of control, which could result in death or serious injury. (00050a)

Rear Sprocket

1. See Figure 1-18. Inspect each tooth of rear sprocket for:
 - a. Major tooth damage.
 - b. Gouges caused by hard objects.
2. Replace rear sprocket if major tooth damage exists.

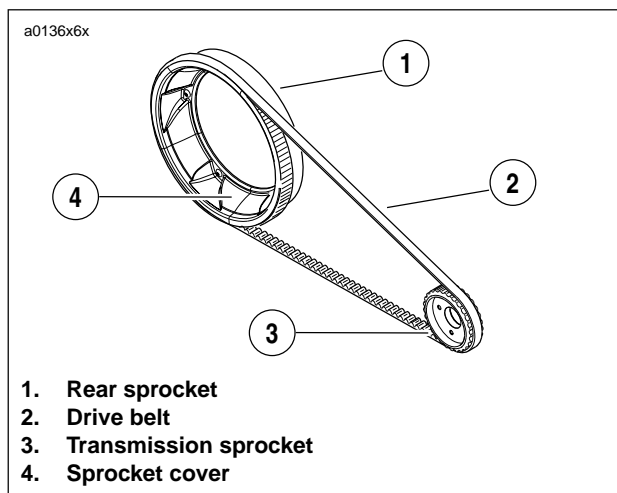


Figure 1-18. Drive Belt Assembly

Drive Belt

See Figure 1-19. Inspect drive belt for:

- Cuts or unusual wear patterns.
- Outside edge bevelling (8). Some bevelling is common, but it indicates that sprockets are misaligned.
- Outside ribbed surface for signs of stone puncture (7). If cracks/damage exists near edge of belt, replace belt immediately. Damage to center of belt will require belt replacement eventually, but when cracks extend to edge of belt, belt failure is imminent.
- Inside (toothed portion) of belt for exposed tensile cords (normally covered by nylon layer and polyethylene layer). This condition will result in belt failure and indicates worn transmission sprocket teeth. Replace belt and transmission sprocket.
- Signs of puncture or cracking at the base of the belt teeth. Replace belt if either condition exists.
- Replace belt if conditions 2, 3, 6 or 7 (on edge of belt) exist.

NOTE

Condition 1 is not grounds for replacing the belt, but it should be watched as it may develop into condition 2 or 3 resulting in a need for belt replacement.

a0147x6x

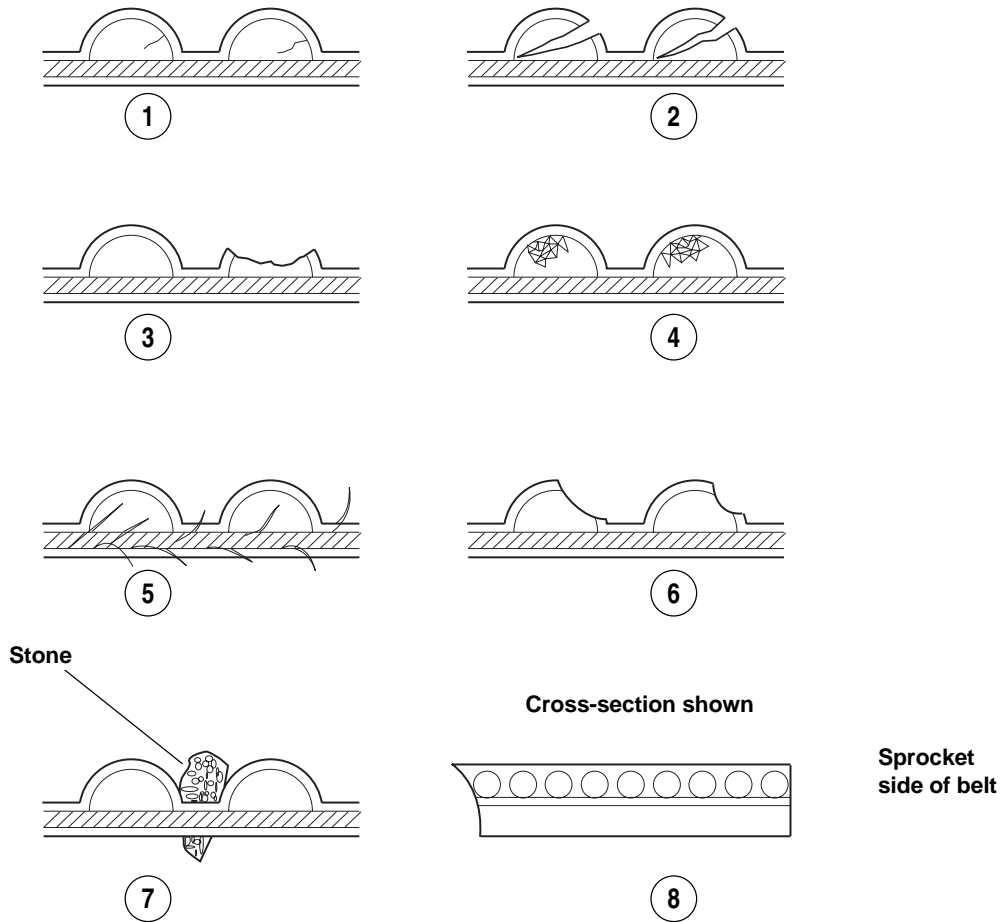


Figure 1-19. Drive Belt Wear Patterns

Table 1-5. Drive Belt Wear Analysis

PATTERN IN FIGURE 1-19.	CONDITION	REQUIRED ACTION
1	Internal tooth cracks (hairline)	OK to run, but monitor condition
2	External tooth cracks	Replace belt
3	Missing teeth	Replace belt
4	Chipping (not serious)	OK to run, but monitor condition
5	Fuzzy edge cord	OK to run, but monitor condition
6	Hook wear	Replace belt
7	Stone damage	Replace belt if damage is on the edge
8	Bevel wear (outboard edge only)	OK to run, but monitor condition

DRIVE BELT AND REAR SPROCKET REPLACEMENT

1. Remove seat. See [2.28 SEAT](#).

⚠ WARNING

To prevent accidental vehicle start-up, which could cause death or serious injury, disconnect negative (-) battery cable before proceeding. (00048a)

2. Disconnect the negative battery cable from the battery.
3. Raise rear wheel off floor using REAR WHEEL SUPPORT STAND (Part No. B-41174).

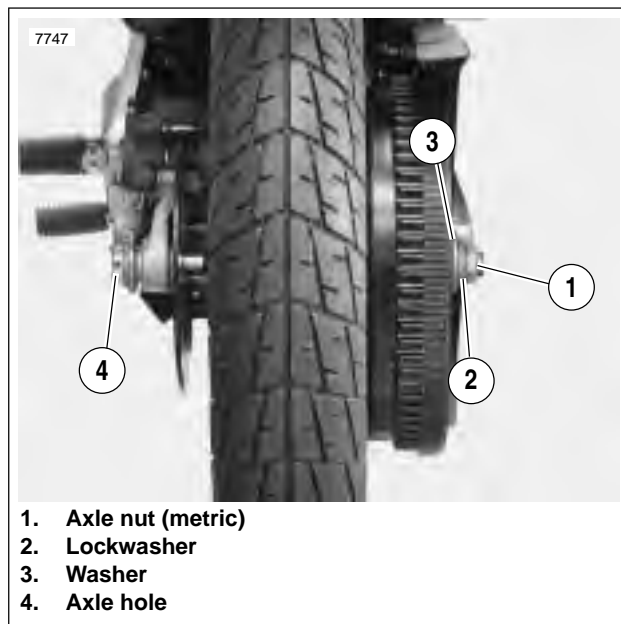


Figure 1-20. Rear Wheel Mounting

4. See [Figure 1-20](#). Place rod or screwdriver through axle hole. Loosen rear axle nut (1) (metric).
5. Remove nut, lockwasher, and flat washer.
6. Pull axle out. Remove right side spacer.
7. Slide carrier with caliper off rotor.
8. Remove left side spacer.
9. Move wheel forward and slide belt off.
10. Remove sprocket cover and five washers from sprocket.
11. Remove and discard sprocket. Discard five washers.

⚠ WARNING

Compressed air can pierce the skin and flying debris from compressed air could cause serious eye injury. Wear safety glasses when working with compressed air. Never use your hand to check for air leaks or to determine air flow rates. (00061a)

12. Clean residual Loctite from threads in wheel sprocket towers with a suitable non-flammable solvent. Dry with compressed air.
13. Remove three TORX bolts, washers and front sprocket cover from right side of motorcycle.

NOTE

It may be necessary to compress suspension to gain access to front sprocket cover TORX bolt.

14. Remove two TORX screws and washers from right side of rear inner fender. Carefully bend rear inner fender upwards and remove drive belt. Discard drive belt.
15. Position **new** drive belt over transmission drive sprocket.
16. Install rear inner fender with two TORX screws and washers. See [2.23 FENDERS](#).
17. Install front sprocket cover with three TORX screws and washers. See [2.22 SPROCKET COVER](#).
18. Position rear sprocket on rear wheel with mounting holes aligned.

⚠ WARNING

Use only new hardened washers between sprocket cover and sprocket. Failure to use hardened washers could cause sprocket to fail. Drive sprocket failure could lead to loss of control of vehicle which could result in death or serious injury.

19. Place **new** hardened (Part No. BA0511.2Z) washers on sprocket and install **new** sprocket cover over washers and sprocket.
20. Install sprocket and sprocket cover with five **new** sprocket bolts. Tighten bolts to 28-31 ft-lbs (38-42 Nm).
21. Place wheel centrally in the swingarm. Slide wheel far enough forward to slip belt over sprocket and rest belt on sprocket inboard of the teeth.

NOTE

Do not place belt on sprocket teeth at this time. Alignment of parts will be difficult. Resting belt next to teeth allows slack for easier alignment of wheel assembly.

22. Hold left side spacer in place and slide caliper and carrier over rotor.
23. See [Figure 1-21](#). Slide axle through washer, swing arm, left side spacer and wheel assembly.
 - a. Hold right side spacer in place.
 - b. Insert axle through right side spacer and swingarm.
 - c. Install flat washer, lockwasher and axle nut.
24. Place screwdriver or rod through axle hole and torque rear axle nut to 49-51 ft-lbs (67-69 Nm).
25. Slide belt on sprocket teeth by rotating wheel to “walk” belt onto teeth.
26. Lower motorcycle rear wheel.
27. Connect negative battery cable to battery. Tighten fastener to 72-96 in-lbs (8-11 Nm).

WARNING

After installing seat, pull upward on front of seat to be sure it is in locked position. While riding, a loose seat can shift causing loss of control, which could result in death or serious injury. (00070a)

28. Install seat. See [2.28 SEAT](#).

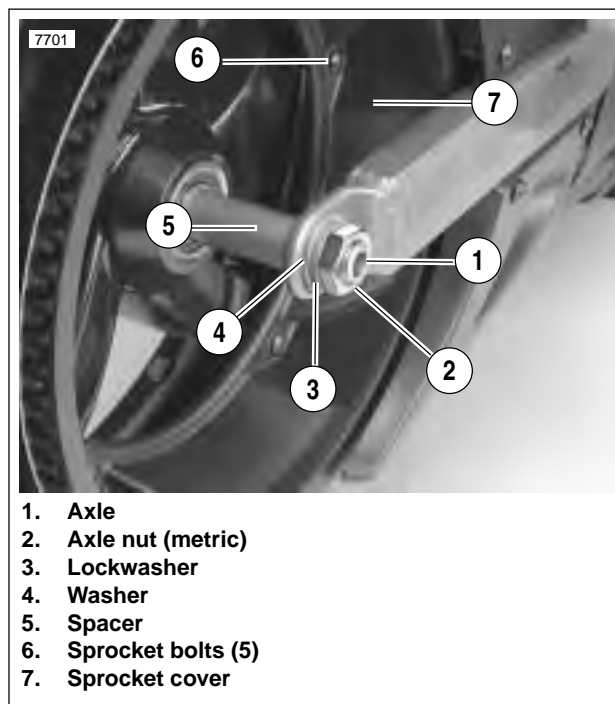


Figure 1-21. Rear Axle, Right Side

ADJUSTMENT

See Figure 1-22. Buell Blast Models are shipped with a spacer between the primary chain limiting screw and the lock nut. The spacer is used to quickly get proper adjustment during production. This spacer should be removed and discarded at the first adjustment interval.

1. See Figure 1-22. Back-off jam nut (3) and chain limiting screw (1).
2. Remove spacer (2).

IMPORTANT NOTE

Be certain to use inch-pound wrench. Chain adjuster shoe can be damaged by excessive force.

3. See Figure 1-24. Tighten chain limiting screw to 24 in-lbs (2.7 Nm).
4. Back-off chain limiting screw 3/4 turn (4 1/2 "flats").
5. Hold chain limiting screw while tightening jam nut to 20-25 ft-lbs (27.1-33.9 Nm).

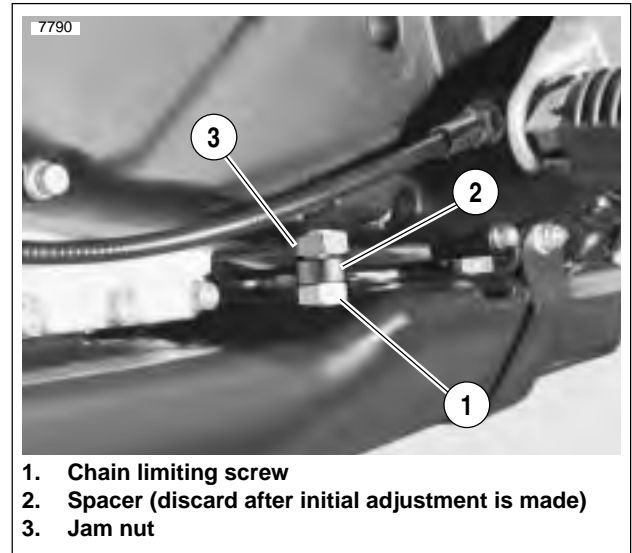


Figure 1-22. Adjustment Nut with Spacer

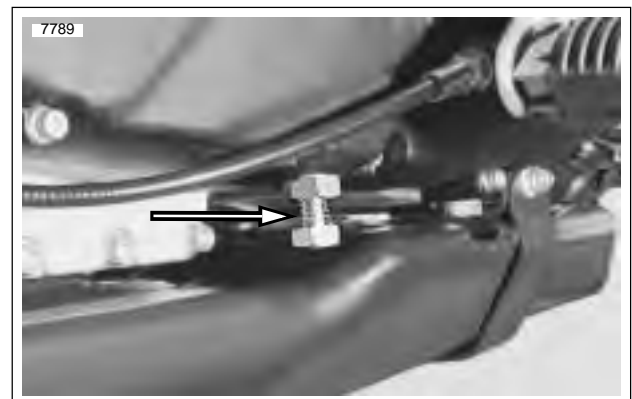


Figure 1-23. Chain Limiting Screw without Spacer



Figure 1-24. Tightening Chain Limiting Screw

GENERAL

Inspect rear shock absorber for proper operation and for oil leaks. Inspect rubber shock eye bushings for deterioration.

NOTE

See [Figure 1-25](#). Damper component (3) cannot be serviced or repaired. If the damper component is leaking or damaged it must be replaced.

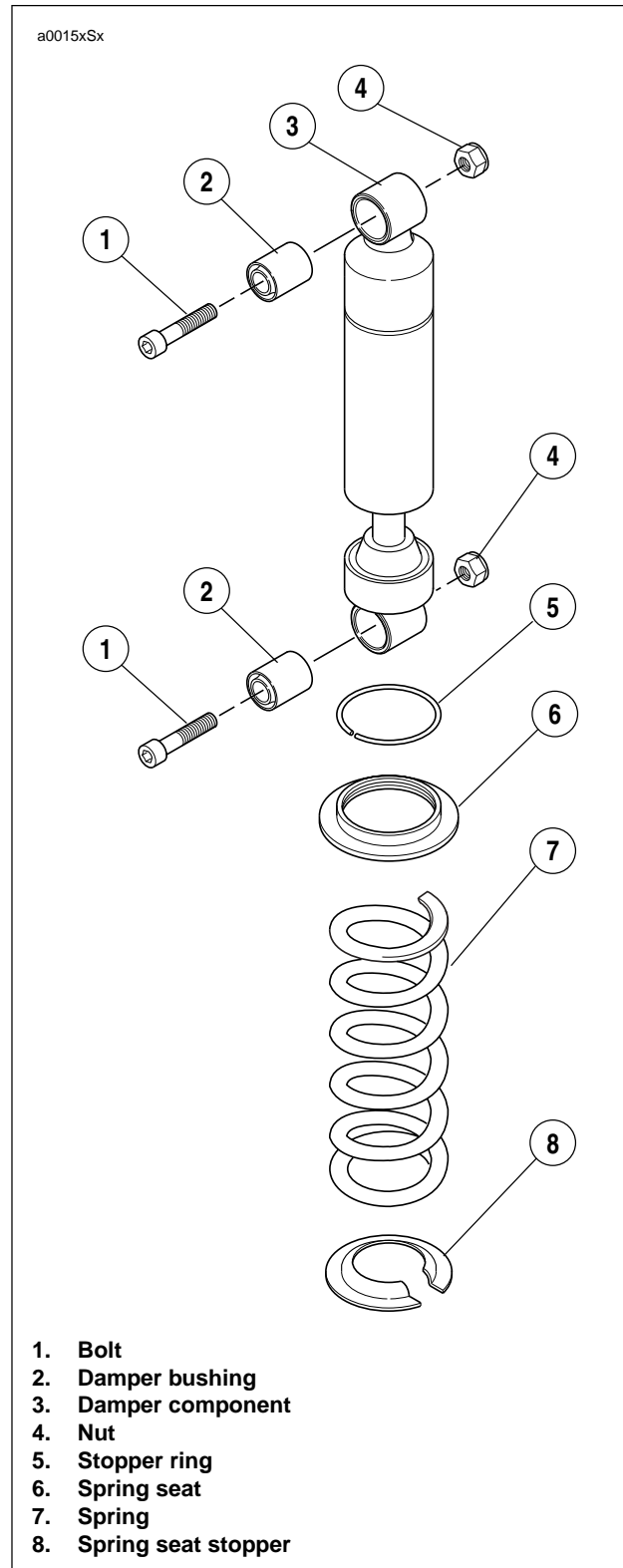


Figure 1-25. Rear Shock Absorber Assembly

FORK OIL CHANGES

1. Remove front forks. See 2.17 FRONT FORK.



Figure 1-26. Clamping the Fork

2. See Figure 1-26. Clamp the fork in a vise with front fork holding tool (part no. B-41177).



Figure 1-27. Slider Tube Cap

3. See Figure 1-27. Remove slider tube cap.



Figure 1-28. B-Spring Seat

4. See Figure 1-28. Push down on the B-spring seat (O-ring included) and remove the stopper ring and spring seat.

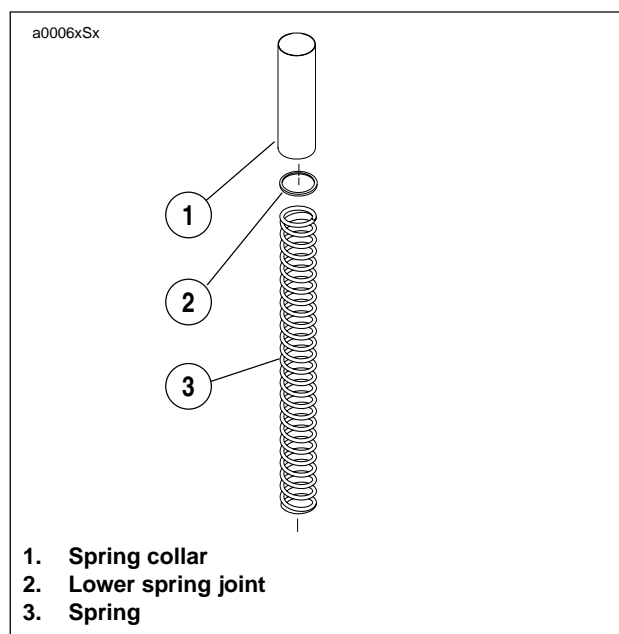


Figure 1-29. Removing Sub-Assembly

5. See Figure 1-29. Remove the spring collar, lower spring joint and spring from slider tube.



Figure 1-30. Pumping Fork Oil

6. See [Figure 1-30](#). Remove the fork oil by pumping the fork leg and rod 8-10 times until the rod moves freely.

NOTE

The recommended fork oil is hydraulic fork oil type "E".

7. Pour 9.2 oz. (272.1 ml) fork oil into fork.
8. Install lower spring joint and spring collar.
9. Coat a **new** O-ring with fork oil or sealing grease.
10. Install **new** O-ring onto spring seat.



Figure 1-31. Compressing Spring Seat

11. See [Figure 1-31](#). Push down on spring seat past groove to install stopper ring. Stopper ring will lock into groove when installed correctly.



Figure 1-32. Slider Tube Cap

12. See [Figure 1-32](#). Install slider tube cap.
13. Install front forks. See [2.17 FRONT FORK](#).

GENERAL

Check steering head bearings:

- When storing or removing the motorcycle for the season.

NOTE

Lubricate the steering head bearings with [WHEEL BEARING GREASE \(Part No. 99855-89\)](#)

INSPECTION

With motorcycle front end raised off of floor, check to make sure front fork turns freely, without any binding or interference. Also check to make sure there is no appreciable front to rear fork shake indicating excessive bearing looseness.

1. Detach clutch cable at handlebar.
2. Remove seat and fuel tank. See [4.2 FUEL TANK COVER/FUEL TANK](#).
3. Attach lifting straps to frame tube behind steering neck. Raise front wheel off floor using a floor hoist and lifting straps.
4. Turn front wheel to full right lock.
5. See [Figure 1-33](#). Attach a spring scale into the hole in the front axle. With scale 90 degrees from fork leg, pull front wheel to center position. It should take 6.5-7 lbs (2.9-3.2 kg) to pull front wheel to center.
6. Attach clutch cable to handlebar.

NOTE

Check that clutch and throttle cables do not bind when measuring bearing resistance.

WARNING

After installing seat, pull upward on front of seat to be sure it is in locked position. While riding, a loose seat can shift causing loss of control, which could result in death or serious injury. (00070a)

7. Install seat and fuel tank. See [4.2 FUEL TANK COVER/FUEL TANK](#).



Figure 1-33. Steering Head Bearing Check

ADJUSTMENT

1. Detach clutch cable at handlebar.
2. Remove seat and fuel tank. See [4.2 FUEL TANK COVER/FUEL TANK](#).
3. Attach lifting straps to frame backbone behind steering neck. Raise front wheel off floor using a floor hoist and lifting straps.
4. Turn front wheel to full right lock.
5. See [Figure 1-33](#). Attach a spring scale into the hole in the front axle. Pull front wheel to center position. It should take 6.5-7 lbs (2.9-3.2 kg) to pull front wheel to center.
6. See [Figure 1-34](#). To adjust:
 - a. Loosen both pinch screws (9) on lower triple clamp.
 - b. Loosen center cap nut pinch screw (2) on upper triple clamp.
 - c. Loosen cap nut (1), then tighten to 48-52 ft-lbs (65-71 Nm) to seat bearing. Loosen cap nut, apply Loctite 243 (blue) to threads of fork stem and retighten cap nut to 28-32 ft-lbs (38-43 Nm).
7. Recheck tension using spring scale.
8. Tighten both lower triple clamp pinch screws (9) to 22-29 ft-lbs (30-39 Nm).
9. Tighten center cap pinch screw to 84-120 **in-lbs** (10-14 Nm).

WARNING

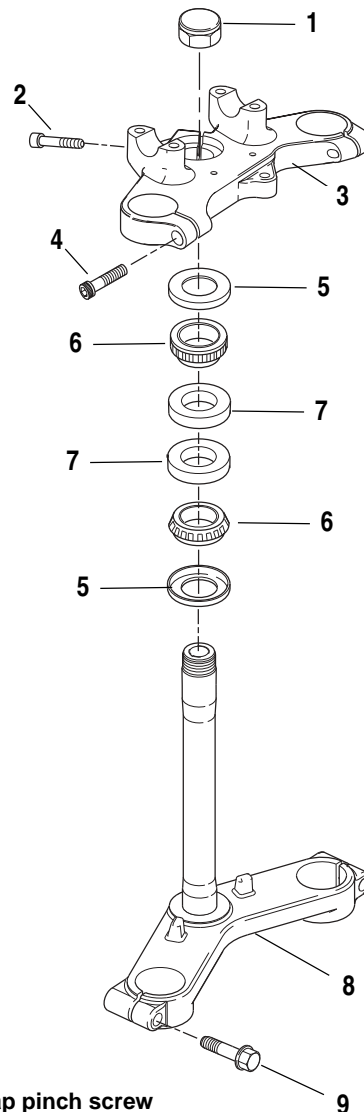
After installing seat, pull upward on front of seat to be sure it is in locked position. While riding, a loose seat can shift causing loss of control, which could result in death or serious injury. (00070a)

10. Install seat and fuel tank. See [4.2 FUEL TANK COVER/FUEL TANK](#).

Lubrication

At 20,000 miles (32,000 km) and every 20,000 miles (32,000 km) thereafter, lubricate the steering head bearings with WHEEL BEARING GREASE (Part No. 99855-89).

a0137x2x



1. Capnut
2. Center cap pinch screw
3. Upper triple clamp
4. Pinch screws (2)
5. Dust shield (2)
6. Bearing (2)
7. Bearing cup (2)
8. Lower triple clamp
9. Pinch screws (2)

Figure 1-34. Fork Stem and Bracket Assembly

GENERAL

Change spark plug at every 10,000 mile (16,000 km) service interval. Use only Harley-Davidson No. 10R12A plug as a replacement.

INSPECTION

1. Disconnect cable from both spark plug by pulling on rubber boot (not cable).
2. Remove spark plug and examine.



Figure 1-35. Typical Spark Plug Deposits

3. See [Figure 1-35](#). Compare your observations of the plug deposits with the descriptions provided below.
 - a. A wet, black and shiny deposit on plug base, electrodes and ceramic insulator tip indicates an oil fouled plug. The condition may be caused by one or more of the following: worn pistons, worn piston rings, worn valves, worn valve guides, worn valve seals, a weak battery or a faulty ignition system.
 - b. A dry, fluffy or sooty black deposit indicates a carburetor air-fuel mixture that is too rich, engine idling for excessive periods of time and/or enrichener usage for excessive periods of time.
 - c. A light brown, glassy deposit indicates an overheated plug. This condition may be accompanied by cracks in the insulator or by erosion of the electrodes and is caused by an air-fuel mixture that is too lean, a hot-running engine, valves not seating or improper ignition timing. The glassy deposit on the spark plug is a conductor when hot and may cause high-speed misfiring. A plug with eroded electrodes, heavy deposits or a cracked insulator must be replaced.
 - d. A plug with a white, yellow, tan or rusty brown powdery deposit indicates balanced combustion. Clean off spark plug deposits at regular intervals.
4. If the plug requires cleaning between tune-ups and replacement plug is not available, proceed as follows:
 - a. De-grease firing end of spark plug using ELECTRICAL CONTACT CLEANER. Dry plug with compressed air.
 - b. Use a thin file to flatten spark plug electrode. A spark plug with sharp edges on its electrodes requires 25%-40% less firing voltage than one with rounded edges.
5. If the plug cannot be cleaned, replace with HD No. 10R12A spark plug.
6. Check electrode gap with a wire-type feeler gauge. Gap should be 0.035 in. (0.9 mm).
7. Apply Loctite Anti-Seize to threads of spark plug. Install and tighten to 12-18 ft-lbs (16-24.4 Nm).
8. Connect spark plug cable. Verify that cable is securely connected to ignition coil and spark plug.

GENERAL

Replace the air cleaner filter element:

- Every 30,000 miles (48,000 km) or as required.

REMOVAL

1. See [Figure 1-36](#). Release five latches around perimeter of air box cover.
2. Remove single Phillips screw at bottom of air box cover (7 o'clock position).
3. Pull cover from air box.
4. Pull conical shaped filter from air box.
5. Squeeze wings on spring clamp with pliers and pull clean air inlet hose from fixed position on allen head screw (gold) at top of venturi ring. Remove screw with spacer.
6. Remove remaining two allen head screws to free venturi ring from carburetor flange.
7. Remove hex screw at bottom of air box (6 o'clock position) to release bracket from crankcase hole.
8. See [Figure 1-37](#). Moving to left side of vehicle, remove two flange bolts to release side of air box from triangular shaped bracket. Do not remove bottom bolt to crankcase.

IMPORTANT NOTE

Do not take bolt in and out of the crankcase unless necessary. Since the potential for stripping always exists during removal and installation, leave the bolt intact to avoid possible damage to the crankcase.

9. Returning to the right side of the vehicle, carefully pull out air box. When partially removed, detach clean air inlet hose from middle fitting on 3-way connector.
10. Remove gasket from inboard side of air box. Discard gasket.

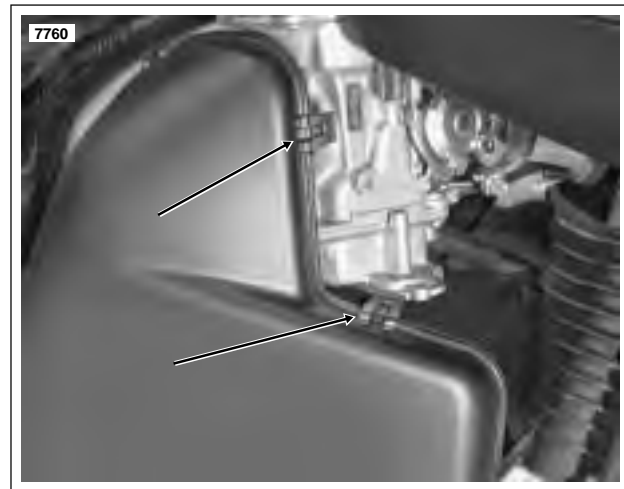


Figure 1-36. Release Air Box Cover Latches



Figure 1-37. Air Cleaner Mounting Bracket (left side)

CLEANING AND INSPECTION

1. Thoroughly clean air cleaner cover and backplate.
2. Replace the filter element if damaged or if filter media cannot be adequately cleaned.

⚠ WARNING

Do not use gasoline or solvents to clean filter element. Flammable cleaning agents can cause an intake system fire, which could result in death or serious injury. (00101a)

3. Wash the filter element (and hose connections) in warm, soapy water. To remove soot and carbon, soak element for 30 minutes in warm water with mild detergent.

⚠ WARNING

Compressed air can pierce the skin and flying debris from compressed air could cause serious eye injury. Wear safety glasses when working with compressed air. Never use your hand to check for air leaks or to determine air flow rates. (00061a)

4. Dry the filter element using low pressure compressed air (32 psi/221 kPa maximum). Rotate the element while moving air nozzle up and down the element exterior. Do not rap the element on a hard surface.
5. Hold the filter element up to a strong light source. The element can be considered sufficiently clean if light is uniformly visible through the media.
6. Inspect all hose connections for cuts, tears, holes or signs of deterioration. Replace as necessary. Direct compressed air through hoses to verify that they are not plugged.

INSTALLATION

1. Obtain a **new** carburetor gasket. Remove the protective paper and place the sticky side of the gasket against the back of the airbox. Use care to align the holes in the gasket with the slotted holes in the airbox.
2. Standing on the right side of the vehicle, start air box into opening below and to the rear of the carburetor. When partially installed, push clean air inlet hose onto middle fitting of 3-way connector.
3. Moving to opposite side of vehicle, apply a small dab of Loctite Low Strength 222 (Purple) to threads of two flange bolts. Slide bolts through top two holes of triangular bracket and install into left side of air box. Alternately tighten screws to 36-60 **in-lbs** (4.1-6.8 Nm).
4. Returning to right side of vehicle, align slots in air box with holes in carburetor flange.
5. Apply a small dab of Loctite 243 (blue) to threads of two short allen head screws. With the flat edge at the top, align holes in venturi ring with holes in carburetor flange. Install screws in the 5 o'clock and 9 o'clock positions. Alternately tighten screws to 24-30 **in-lbs** (2.8.-3.3 Nm).
6. Slide spacer onto longer allen head screw (gold), if removed. Apply a small dab of Loctite 243 (blue) to threads of screw and install into remaining hole in venturi ring (2 o'clock position). Tighten screw to 24-30 **in-lbs** (2.8.-3.3 Nm).

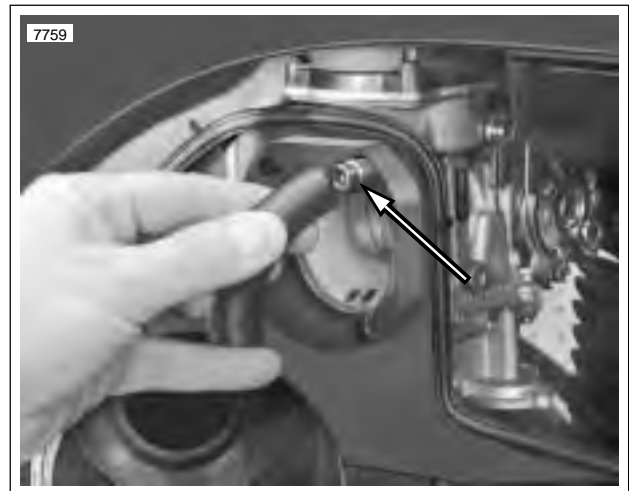


Figure 1-38. Fix Hose End Onto Allen Head Screw

7. See [Figure 1-38](#). Squeeze wings on spring clamp with pliers and push free end of clean air inlet hose over head of gold screw (and spacer) to fix position.
8. Apply one drop of Loctite Threadlocker 271 (red) to threads of hex screw. Install screw at bottom of air box (6 o'clock position) to secure air box bracket to crankcase hole. Tighten screw to 120-144 **in-lbs** (13.6-16.3 Nm).
9. With the larger OD inboard, install conical shaped filter into air box.

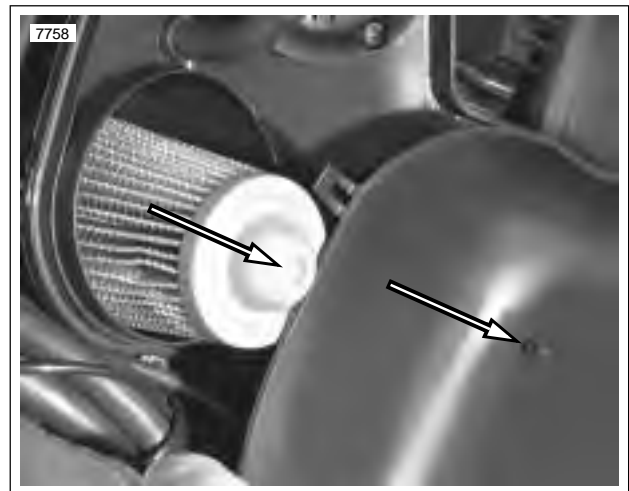


Figure 1-39. Install Air Box Cover Aligning The Index Pin To The Depression In The Air Filter

10. See [Figure 1-39](#). Taking note of index pin on inboard side of cover and small depression at tip of cone, position cover onto air box so that pin engages depression.
11. Lock five latches around perimeter of air box cover.
12. Install Phillips screw at bottom of air box cover (7 o'clock position) to secure cover to air box. Tighten screw to 4-6 **in-lbs** (0.5-0.7 Nm).

GENERAL

- Lubricate throttle control cables with LUBIT-8 TUFOIL CHAIN AND CABLE LUBE (Part No. 94968-85TV).
- Check throttle cable adjustment before every ride.

⚠ WARNING

Throttle cables must not pull tight when handlebars are turned fully to left or right fork stops. Be sure wires and throttle cables are clear of fork stops at steering head so they will not be pinched when fork is turned against stops. Steering must be smooth and free with no binding or interference. Anything interfering with carburetor operation can cause loss of vehicle control which could result in death or serious injury.

ADJUSTMENT

With engine running, turn handlebars through full range of travel. If engine speed changes during this maneuver, adjust throttle cables as follows:

1. See [Figure 1-40](#). Slide rubber boot (5) off cable adjuster (2).
2. Loosen cable adjuster lock (1) on each adjuster.
3. Turn adjusters (2) in direction which will shorten cable housings to minimum length.
4. Point front wheel straight ahead. Twist throttle control grip to fully open position; hold in position.
5. Turn adjuster on throttle control cable (3) until throttle cam stop touches carburetor stop plate. Tighten adjuster lock on throttle control cable adjuster; release throttle control grip.
6. Turn handlebars fully to right. Turn adjuster on idle control cable (4) until end of cable housing just touches the carburetor cable guide.
7. Twist and release throttle control grip a few times. Carburetor throttle must return to idle position each time throttle grip is released. If this is not the case, turn adjuster on idle control cable (4) (shortening cable housing) until throttle control functions properly.
8. Tighten adjuster lock on idle control cable adjuster. Recheck operation of throttle control (Step 7).

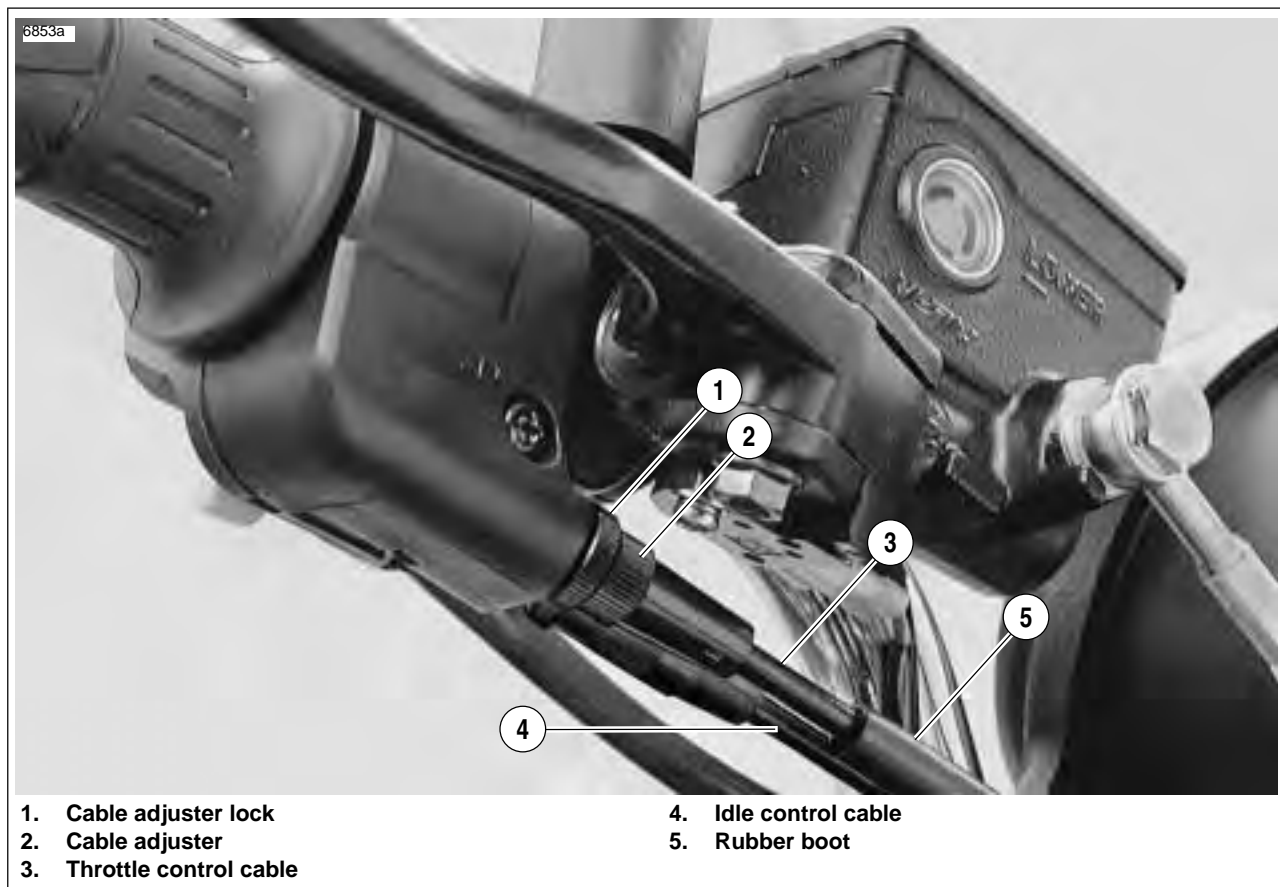


Figure 1-40. Throttle Cables

GENERAL

Check engine idle speed (**after** bike has warmed up).

DYNAMIC TIMING

NOTE

Use static timing method if inductive timing light is not available. See 7.8 IGNITION MODULE AND CAM POSITION SENSOR.

1. Remove hex socket timing plug from timing inspection hole, which is located on right crankcase half and centered below engine cylinders. Install TIMING MARK VIEW PLUG (Part No. HD-96295-65D) into timing inspection hole. Make sure view plug does not touch flywheel.
2. Connect leads of INDUCTIVE TIMING LIGHT (Part No. HD-33813) to spark plug cable, battery positive (+) terminal, and suitable ground.
3. Make sure vacuum hose is properly installed at carburetor. Start engine.
4. Make sure sidestand is up and transmission is in NEUTRAL.
5. Set engine speed to 1200 RPM.

IMPORTANT NOTE

When checking ignition timing, always check at the rpm listed. Failure to do so can result in running engine with too much spark advance, and could cause extreme engine knock and engine failure.

6. See Figure 1-41. Timing light will flash each time an ignition system spark occurs. Aim timing light into timing inspection hole. The advance timing mark (two dots) should be centered in timing inspection hole. If this is the case, ignition timing is properly adjusted. Go to Step 11. If timing mark is not centered or is not visible in the timing inspection hole, see to Steps 7-12.
7. See Figure 1-42. Drill hole in location shown and remove outer timer cover, if not removed.
8. Loosen module plate screws just enough to allow sensor plate to be rotated using a screwdriver in the plate's notch.
9. With timing light aimed into inspection hole, rotate module plate until advance timing mark is centered in timing inspection hole as shown in Figure 1-41.
10. See Figure 1-42. Tighten module plate screws to 15-30 in-lbs (1.7-3.4 Nm)
11. Install **new** outer cover, if removed.
12. Remove TIMING MARK VIEW PLUG from timing inspection hole. Install hex socket timing plug. Tighten timing plug to 10-15 ft-lbs (14-21 Nm).

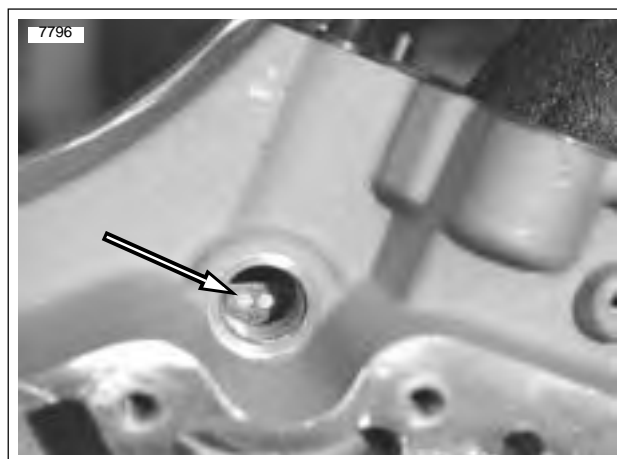


Figure 1-41. Advance Timing Mark for Dynamic Ignition Timing

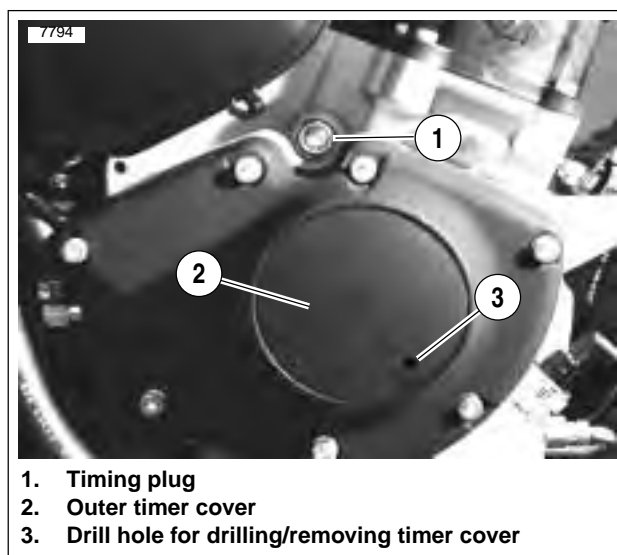


Figure 1-42. Timer Cover and Inspection Hole

IDLE SPEED ADJUSTMENT

NOTE

The Blast P3 is equipped with an auto-enrichener that automatically increases the idle speed and richens the fuel mixture at startup. To correctly set the idle speed, the auto-enrichment cycle must be complete (idle speed has slowed from startup).

Check idle speed adjustment **after** the bike is warmed up.

See [Figure 1-43](#). Regular idle speed is 1200 RPM. Set idle speed using remote idle adjustment screw.

1. Perform dealer road test first.

NOTE:

Be sure the engine is warmed up to normal operating temperature. Be aware that because there are variations in individual components, it is possible for a properly warmed-up engine to idle at 2000 RPM.

2. See [Figure 1-44](#). The ignition coil cable is located on the left side of the bike behind the fuel supply valve. With the bike running, place hand held tachometer on ignition coil cable.
3. Press the tachometer button to obtain a reading for the current RPM.
4. See [Figure 1-43](#). Set engine speed by turning the idle adjuster clockwise to increase speed or counter clockwise to decrease speed until the tachometer has a reading of 1200 RPM.
5. Turn the ignition switch to off position.

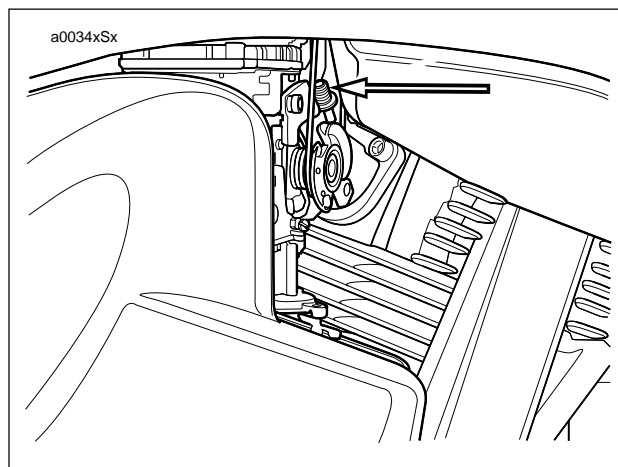
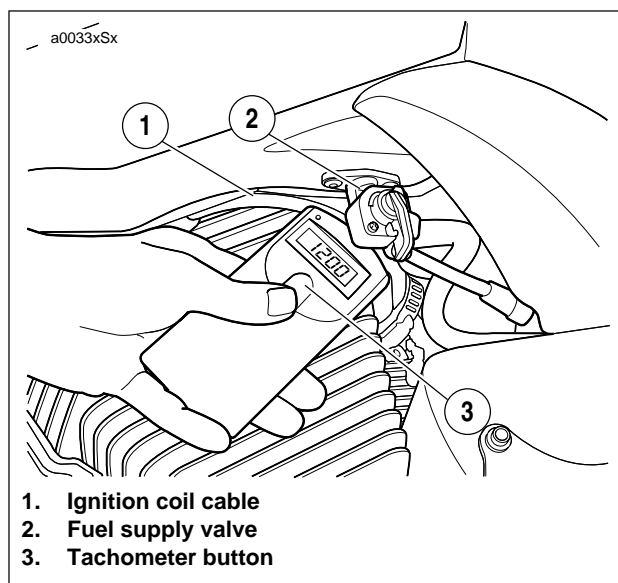


Figure 1-43. Adjusting Idle Speed Using Idle Adjustment Screw



1. Ignition coil cable
2. Fuel supply valve
3. Tachometer button

Figure 1-44. Checking RPM Using a Hand Held Tachometer

REMOVAL

WARNING

Stop the engine when refueling or servicing the fuel system. Do not smoke or allow open flame or sparks near gasoline. Gasoline is extremely flammable and highly explosive, which could result in death or serious injury. (00002a)

1. Remove seat. Depress latch at bottom and pull seat up and back to remove.

WARNING

To prevent accidental vehicle start-up, which could cause death or serious injury, disconnect negative (-) battery cable before proceeding. (00048a)

2. Unthread bolt and remove battery negative cable (black) from battery negative (-) terminal.
3. Drain fuel tank as follows:
 - a. See [Figure 1-45](#). Rotate handle on the fuel supply valve to the fully vertical position (4) to shut the gasoline supply to the carburetor OFF.

WARNING

Gasoline can drain from the fuel line when disconnected from fuel tank. Gasoline is extremely flammable and highly explosive, which could result in death or serious injury. Wipe up spilled fuel immediately and dispose of rags in a suitable manner. (00260a)

- b. Turn slotted screw to loosen band clamp on outlet fitting at side of fuel valve. Pull hose from fitting.
- c. Attach length of spare hose to outlet fitting. Place free end of hose into a suitable container.
- d. See [Figure 1-45](#). Rotate handle of fuel supply valve to RES (reserve) (6) of to start the flow of fuel.
- e. Once the fuel tank is completely drained, rotate handle of fuel supply valve to OFF. Remove spare hose from outlet fitting.

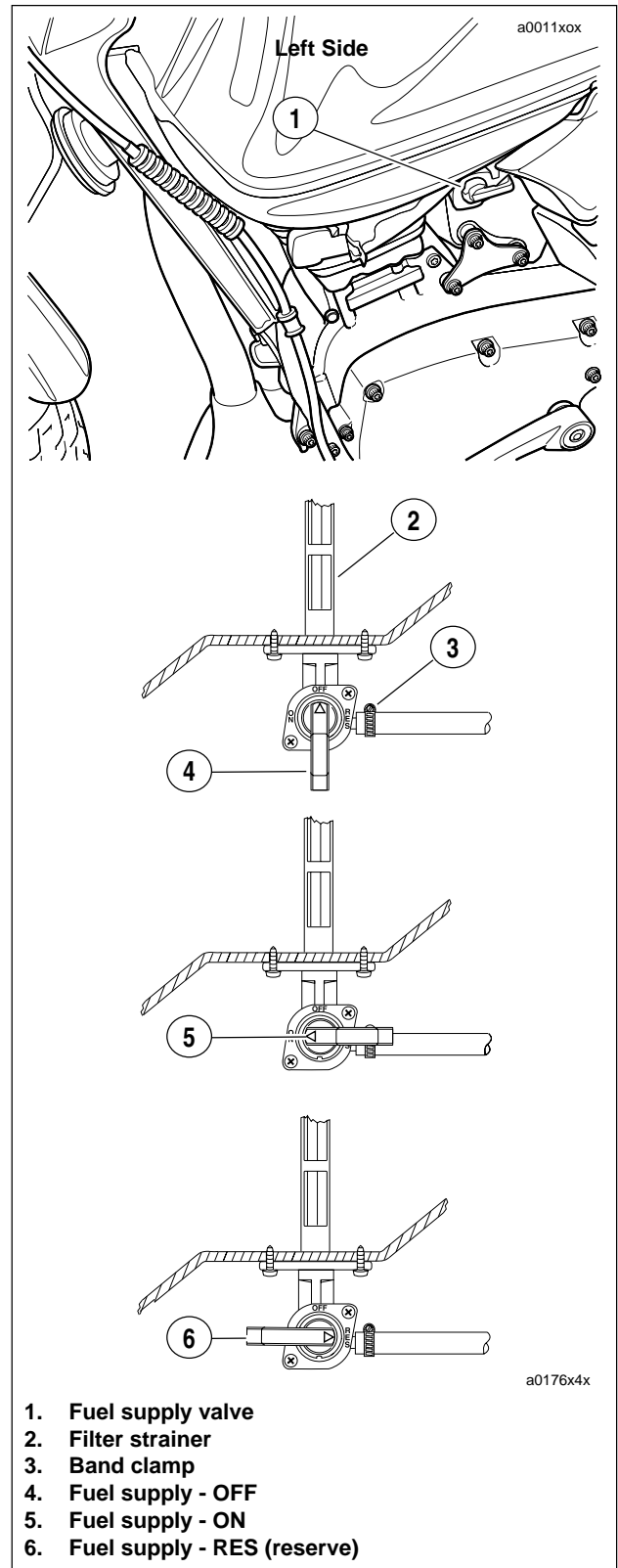


Figure 1-45. Fuel Supply Valve

⚠ WARNING

With fuel tank drained, gasoline can spill from bore when supply valve is loosened or removed. Gasoline is extremely flammable and highly explosive, which could result in death or serious injury. Wipe up spilled fuel immediately and dispose of rags in a suitable manner. (00277a)

4. Remove two allen head screws from fuel valve and pull assembly from fuel tank bore.
5. Remove o-ring from flange of fuel valve assembly. Discard o-ring.
6. Carefully unthread fuel filter strainer from fuel valve assembly.

CLEANING AND INSPECTION

Clean strainer using a suitable solvent. Replace strainer if any damage is found.

INSTALLATION

1. Carefully thread fuel filter strainer onto fuel valve assembly.
2. Install **new** o-ring into groove on flange of fuel valve assembly.
3. Insert fuel valve assembly into fuel tank bore and install two allen head screws. Alternately tighten screws to 19-21 **in-lbs** (2.2-2.3 Nm).
4. Push hose onto outlet fitting at side of fuel valve. Turn slotted screw to tighten band clamp.
5. Verify that handle of fuel supply valve is in the "OFF" position and fill the fuel tank.
6. Rotate handle of fuel supply valve to "ON" and carefully inspect for fuel leaks. Return the valve to the "OFF" position when finished.
7. Insert bolt through battery negative cable (black) into threaded hole of battery negative (-) terminal. Tighten bolt to 72-96 **in-lbs** (8-11 Nm).

⚠ WARNING

After installing seat, pull upward on front of seat to be sure it is in locked position. While riding, a loose seat can shift causing loss of control, which could result in death or serious injury. (00070a)

8. Position seat on frame backbone, so that tongue at bottom engages slot in frame weldment. Push down on rear of seat until spring-loaded latch fully engages groove of seat pin.

STARTER INTERLOCK AND ELECTRICAL SWITCHES 1.21

GENERAL

Lubricate sidestand with Loctite Lubriplate or Lithium Grease.

Inspect all electrical equipment and switches, including starter interlock for proper operation before every ride.

TESTING INTERLOCK

The starter/ignition interlock system is designed to prevent unintended start-up and/or forward motion of the motorcycle. One of three conditions must exist to allow operation of the vehicle:

- Clutch disengaged (lever pulled in - must be done whenever starting motorcycle).
- Transmission in neutral.
- Sidestand retracted.

If the motorcycle starts and operates without any of the three conditions being met, see [7.11 STARTER/IGNITION INTERLOCK](#), for troubleshooting procedures.

TESTING SWITCHES

Check the following electric switches for proper operation:

- Left and right directional signals and dash indicator.
- Neutral indicator light on dash.
- Headlamp low and high beam, high beam flash and high beam indicator light.
- Oil pressure indicator light.
- Odometer reset switch.
- Tail lamp.
- Brake lamp with both front and rear brake application.
- Speedometer.
- Horn.
- Ignition stop/run switch.
- Electric starter switch.

INSPECTION

WARNING

The automatic-on headlamp feature provides increased visibility of the rider to other motorists. Be sure headlamp is on at all times. Poor visibility of rider to other motorists can result in death or serious injury. (00030b)

Check headlamp beam for proper height and lateral alignment as follows:

1. Verify correct front and rear tire inflation pressure. See [1.8 TIRES AND WHEELS](#).
2. Place motorcycle on level floor (or pavement) in an area with minimum light.
3. See [Figure 1-46](#). Point front of motorcycle toward a screen or wall which is 25 ft (7.62 M) away from front tire contact patch on floor (directly below front axle).
4. Draw a horizontal line on the screen or wall 35 in. (88.9 cm) above the floor.
5. Have a person whose weight is roughly the same as that of the principal rider sit on motorcycle seat. Weight of rider will compress vehicle suspension slightly.
6. Stand motorcycle upright with both tires resting on floor and with front wheel held in straight alignment (directly forward).
7. Turn ignition switch to IGN. Set handlebar headlamp switch to HIGH beam position.
8. Check light beam for proper height alignment. Main beam of light (broad, flat pattern of light) should be centered on horizontal line on screen or wall (i.e. equal area of light above and below line).
9. Check light beam for proper lateral alignment. Main beam of light should be directed straight ahead (i.e. equal area of light to right and left of center).
10. Adjust headlamp if necessary. See [ADJUSTMENT](#).

ADJUSTMENT

1. See [Figure 1-47](#). To adjust headlamp turn vertical headlamp mounting adjuster (1) clockwise to raise beam height.
2. Turn horizontal headlamp mounting adjuster (2) clockwise to change lateral alignment.

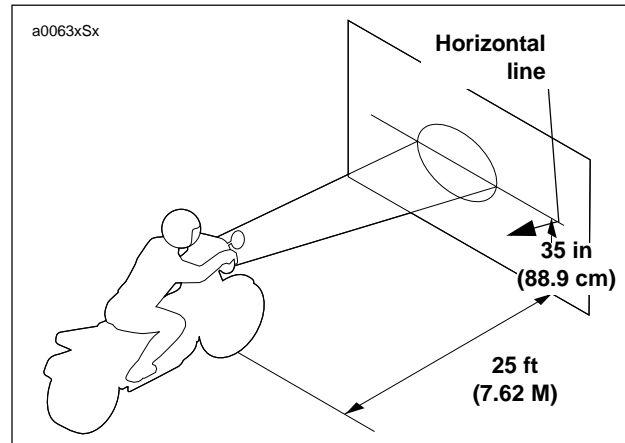
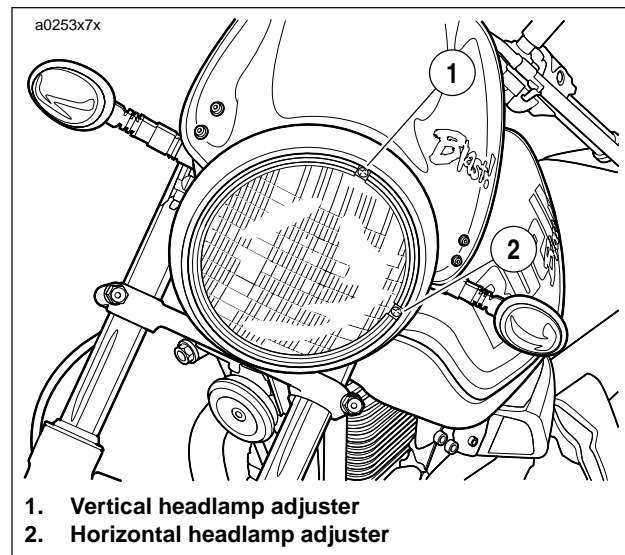


Figure 1-46. Checking Headlamp Alignment



1. Vertical headlamp adjuster
2. Horizontal headlamp adjuster

Figure 1-47. Headlamp Adjustment

GENERAL

Check stabilizer links and engine mounts for damage and hardware for proper tightness:

Inspect muffler strap and exhaust system hardware for damage and proper tightness:

Inspect critical fasteners (listed below) for proper tightness as recommended in [1.3 MAINTENANCE SCHEDULE](#).

TORQUE VALUES

ITEM	TORQUE	
Left handlebar control fasteners	25-33 in-lbs	2.8-3.7 Nm
Right handlebar control fasteners	25-33 in-lbs	2.8-3.7 Nm
Handlebar fasteners	120-144 in-lbs	14-16 Nm
Brake banjo bolts	16-20 ft-lbs	22-27 Nm
Front brake caliper mounting bolts	18-22 ft-lbs	24-30 Nm
Rear (large) brake caliper mounting bolt	18-22 ft-lbs	24-30 Nm
Rear (small) brake caliper mounting bolt	14.5-18 ft-lbs	20-24 Nm
Brake caliper pin	132-174 in-lbs	15-20 Nm
Front rotor TORX screws	24-27 ft-lbs	33-37 Nm
Rear rotor TORX screws	24-27 ft-lbs	33-37 Nm
Front axle nut	38-42 ft-lbs	52-57 Nm
Rear axle nut	49-51 ft-lbs	67-69 Nm
Front fork upper triple clamp pinch bolts (at sliders)	13-16 ft-lbs	18-22 Nm
Front fork upper triple clamp pinch bolts (at center cap)	84-120 in-lbs	10-14 Nm
Front fork lower triple clamp pinch bolts	22-29 ft-lbs	30-39 Nm
Muffler fasteners (front and rear)	17-19 ft-lbs	24-25 Nm
Tie bar (all)	30-33 ft-lbs	41-45 Nm
Front isolator mounting bolt	63-70 ft-lbs	86-95 Nm
Frame to rear isolator fastener	30-33 ft-lbs	41-45 Nm

ENGINE

The following check list can be helpful in locating most operating troubles. Refer to the appropriate sections in this Service Manual for detailed procedures.

Starter Motor Does Not Operate or Does Not Turn Engine Over

1. Engine run switch in OFF position.
2. Ignition switch not on.
3. Discharged battery, loose or corroded connections. (Solenoid chatters.)
4. Starter control relay or solenoid not functioning.
5. Electric starter shaft pinion gear not engaging or over-running clutch slipping.
6. Clutch lever not pulled in.

Engine Turns Over But Does Not Start

1. Fuel tank empty.
2. Fuel valve turned off.
3. Fuel valve or filter clogged.
4. Discharged battery, loose or broken battery terminal connections.
5. Fouled spark plug.
6. Spark plug cable in bad condition and shorting or cable connections loose.
7. Ignition timing badly out of adjustment.
8. Loose wire connection at coil or battery connection or plug between ignition sensor and module.
9. Ignition coil not functioning.
10. Ignition module not functioning.
11. Ignition sensor not functioning.
12. Sticking or damaged valve or valves.
13. Engine flooded with gasoline as a result of over choking.
14. Engine oil too heavy (winter operation).

Starts Hard

1. Spark plug in bad condition, have improper gap or are partially fouled.
2. Spark plug cable in bad condition and shorting.
3. Battery nearly discharged.
4. Loose wire connection at one of the battery terminals, at coil, or at plug between ignition sensor and module.
5. Carburetor controls not adjusted correctly.
6. Ignition coil not functioning.
7. Engine oil too heavy (winter operation).
8. Ignition not timed properly.
9. Fuel tank filler cap vent plugged, or carburetor fuel line closed off restricting fuel flow.
10. Water or dirt in fuel system and carburetor.
11. Enrichener valve inoperative.
12. Air leak at intake manifold.

13. Valves sticking.

Starts But Runs Irregularly or Misses

1. Spark plug in bad condition or partially fouled.
2. Spark plug cable in bad condition and shorting.
3. Spark plug gap too close or too wide.
4. Ignition coil not functioning.
5. Ignition module not functioning.
6. Ignition sensor not functioning.
7. Battery nearly discharged.
8. Damaged wire or loose connection at battery terminals or coil.
9. Intermittent short circuit due to damaged wire insulation.
10. Water or dirt in fuel system and carburetor or filter.
11. Fuel tank filler cap vent plugged or carburetor float bowl vent closed off.
12. Carburetor controls improperly adjusted.
13. Air leak at intake manifold or air cleaner.
14. Damaged intake or exhaust valve.
15. Weak or broken valve springs.
16. Incorrect valve timing.

Spark Plug Fouls Repeatedly

1. Incorrect spark plug.
2. Piston rings badly worn or broken.
3. Fuel mixture too rich (see CARBURETOR TROUBLESHOOTING).
4. Valve stem seals worn or damaged.
5. Valve guides badly worn.

Pre-Ignition or Detonation (Knocks or Pings)

1. Excessive carbon deposit on piston head or combustion chamber.
2. Incorrect heat range spark plug.
3. Spark plug not firing.
4. Ignition timing advanced.
5. Fuel octane rating too low.
6. Intake manifold vacuum leak.

Overheating

1. Insufficient oil supply, or oil not circulating.
2. Leaking valves.
3. Heavy carbon deposit.
4. Ignition timing retarded.

Valve Train Noise

1. Hydraulic lifter not functioning properly.
2. Bent push rod.
3. Cam, cam gears, or cam bushings worn.
4. Rocker arm binding on shaft.
5. Valve sticking in guide.

Excessive Vibration

1. Upper mounting bracket loose, broken or improperly spaced.
2. Lower mounting bolts loose.
3. Broken frame.
4. Primary chain badly worn or links tight as a result of insufficient lubrication.
5. Wheels not aligned and/or tires worn.
6. Internal engine problem.
7. Engine mount loose or broken.

ENGINE LUBRICATION SYSTEM

Oil Does Not Return To Oil Reservoir

1. Oil reservoir empty.
2. Return pump gears damaged.
3. Oil feed pump not functioning.
4. Restricted oil lines or fittings.

Engine Uses Too Much Oil or Smokes Excessively

1. Piston rings badly worn or broken.
2. Valve stem seals worn or damaged.
3. Valve guides worn.

Engine Leaks Oil From Cases, Push Rods, Hoses, Etc.

1. Loose parts.
2. Imperfect seal at gaskets, push rod cover, washers, etc. To aid locating leaks, use BLACK LIGHT LEAK DETECTOR (Part No. HD-35457).
3. Restricted oil return line to reservoir.
4. Restricted breather passage(s) to air cleaner.

ELECTRICAL SYSTEM

Alternator Does Not Charge

1. Regulator-rectifier module not functioning.
2. Rectifier not grounded.
3. Engine ground wire loose or broken.
4. Loose or broken wires in charging circuit.
5. Stator not functioning.
6. Rotor not functioning.

Alternator Charge Rate Is Below Normal

1. Regulator-rectifier module not functioning.
2. Stator not functioning.
3. Rotor not functioning.
4. Weak battery.
5. Loose connections.

FUEL

Carburetor Floods

1. Inlet valve sticking.
2. Inlet valve and/or valve seat worn or damaged.
3. Dirt or other foreign matter between valve and its seat.
4. Float misadjusted or filled with fuel.

TRANSMISSION

Shifts Hard

1. Clutch dragging slightly.
2. Shifter forks (inside transmission) damaged.
3. Corners worn off shifter clutch dogs (inside transmission).

Jumps Out of Gear

1. Shifter pawl improperly adjusted.
2. Shifter engaging parts (inside transmission) badly worn and rounded.
3. Shifter forks bent.
4. Damaged gears.

CLUTCH

Slips

1. Clutch controls improperly adjusted.
2. Worn friction plates.

Drags or Does Not Release

1. Clutch controls improperly adjusted.
2. Clutch plates excessively warped.

Chatters

1. Friction or steel plates worn, warped, or dragging.

CHASSIS

Irregular/Inadequate Brake Action

1. Master cylinder low on fluid.
2. Brake line contains air bubbles.
3. Master or wheel cylinder piston worn.
4. Brake pads impregnated with grease or oil.
5. Brake pads badly worn (1/16 in. (1.6 mm) minimum lining thickness).
6. Brake disc badly worn or warped.
7. Brake pads dragging or excessive braking (brake fades due to heat buildup).
8. Insufficient brake pedal or hand lever free play (brake drags).

Handling Irregularities

1. Tires improperly inflated. Check [2.2 TIRE SPECIFICATIONS](#). Do not overinflate.
2. Loose wheel axle nuts. Tighten front nut to 38-42 ft-lbs (52-57 Nm). Tighten rear nut to 49-51 ft-lbs (67-69 Nm).
3. Excessive wheel hub bearing play.
4. Rear wheel out of alignment with frame and front wheel.
5. Rims and tires out-of-true sideways (tire runout should not be more than 5/64 in. (2.0 mm)).
6. Rims and tires out-of-round or eccentric with hub (tire runout should not be more than 3/32 in. (2.4 mm)).
7. Irregular or peaked front tire tread wear.
8. Tire and wheel unbalanced.
9. Steering head bearings improperly adjusted. Correct adjustment, and replace pitted or worn bearings and races. See [2.18 FORK STEM AND BRACKET ASSEMBLY](#).
10. Shock absorber not functioning normally.
11. Heavy front end loading. Non-standard equipment on the front end (such as heavy radio receivers, extra lighting equipment, or luggage) tends to cause unstable handling.

SUBJECT	PAGE NO.
2.1 Specifications	2-1
2.2 Tire Specifications	2-4
2.3 Vehicle Identification Number (V.I.N.)	2-5
2.4 Wheels	2-7
2.5 Front Wheel	2-9
2.6 Rear Wheel	2-12
2.7 Sealed Wheel Bearings	2-15
2.8 Checking Cast Rim Runout	2-18
2.9 Tires	2-19
2.10 Front Brake Master Cylinder	2-23
2.11 Front Brake Caliper	2-28
2.12 Front Brake Line	2-32
2.13 Rear Brake Master Cylinder	2-33
2.14 Rear Brake Caliper	2-38
2.15 Rear Shock Absorber	2-42
2.16 Throttle Control	2-43
2.17 Front Fork	2-45
2.18 Fork Stem And Bracket Assembly	2-56
2.19 Swingarm	2-58
2.20 Exhaust System	2-59
2.21 Footpeg Support Brackets	2-61
2.22 Sprocket Cover	2-62
2.23 Fenders	2-63
2.24 Lower Belt Guard	2-65
2.25 Tail Section And Rear Frame Assembly	2-66
2.26 Windscreen	2-68
2.27 Instrument Panel	2-69
2.28 Seat	2-70
2.29 Sidestand	2-71
2.30 Handlebars	2-72
2.31 Front And Rear Isolators	2-73

Table 2-1. Chassis Specifications

DIMENSIONS	IN.	MM
Wheel Base	55.0	1397
Seat Height - Low Seat	25.50	648
High Seat	27.50	699
Road Clearance	3.88	99.0
Trail	3.4	86
Rake	25°	

Table 2-2. Weight Specifications

WEIGHT-U.S. MODELS	LBS.	KG
Wet Weight	390	177
GVWR	780	354
GAWR Front	280	127
GAWR Rear	500	227
Load Capacity	390	177

NOTE

See information decal on frame steering head for Gross Vehicle Weight Rating (GVWR) (maximum allowable loaded vehicle weight) and corresponding Gross Axle Weight Ratings (GAWR).

Table 2-3. Fluid Capacities

CAPACITIES	U.S.	Metric
Fuel Tank: Total (including reserve)	2.8 gallons	10.60 liters
Reserve	0.55 gallons	2.08 liters
Oil Tank (with filter)	2.0 quarts	1.89 liters
Transmission/Primary	32.0 ounces	946.0 ml
Front Fork (each-wet capacity)	9.2 ounces	272.0 ml

NOTE

Use a good quality unleaded gasoline which is **87 pump octane** or higher $(R+M)/2$. Octane rating is usually found on the pump.

⚠ WARNING

Do not inflate tire beyond maximum pressure as specified on sidewall. Over inflated tires can blow out, which could result in death or serious injury. (00027a)

Table 2-4. Tire Pressures

Dunlop Tires (only)	FRONT		REAR	
	PSI	kPa	PSI	kPa
Solo Rider	28	193	30	207
Rider & Passenger	32	220	36	248

TORQUE VALUES

ITEM	TORQUE		NOTES
Brake bleeder valve	36-60 in-lbs	4-7 Nm	Metric, Page 2-23
Brake line to master cylinder banjo bolts	16-20 ft-lbs	22-27 Nm	Page 2-27
Clutch lever screw	40-48 in-lbs	4.6-5.4 Nm	Page 2-72
Footpeg support mounting bracket bolts	25-30 ft-lbs	34-41 Nm	Page 2-61
Frame-to-isolator rear fastener	30-33 ft-lbs	41-45 Nm	Apply several drops of Loctite Threadlocker 271 (red) to last few threads, Page 2-74
Front and rear brake rotor screws, TORX	24-27 ft-lbs	33-37 Nm	Tighten in criss-cross pattern. Apply several drops of Loctite Threadlocker 271 (red) to last few threads, Page 2-13
Front axle nut	38-42 ft-lbs	52-57 Nm	Apply several drops of Loctite 243 (blue) to last few threads. Metric, Page 2-11
Front axle pinch screw	13-16 ft-lbs	18-22 Nm	Metric, Page 2-11
Front brake caliper mounting bolts	18-22 ft-lbs	24-30 Nm	Apply several drops of Loctite Threadlocker 271 (red) to last few threads, Page 2-30
Front brake caliper pad hanger pin	11-15 ft-lbs	15-20 Nm	Metric, Page 2-30
Front brake hand lever nut	44-62 in-lbs	5-7 Nm	Metric, Page 2-26
Front brake line clamp screw	36-60 in-lbs	4-7 Nm	Page 2-32
Front brake switch screw	7-13 in-lbs	0.8-1.5 Nm	Page 2-26
Front fender mounting screws	27-30 in-lbs	3.1-3.4 Nm	Page 2-63
Front isolator mount bolt	63-70 ft-lbs	85-95 Nm	Page 2-73
Front muffler bolts	17-19 ft-lbs	24-25 Nm	Page 2-59
Front sprocket cover bolts	30-36 in-lbs	3-4 Nm	Page 2-62
Front tie bar bolt	30-33 ft-lbs	41-45 Nm	Page 2-73
Handlebar clamp fasteners	120-144 in-lbs	14-16 Nm	Page 2-72
Handlebar left and right housing screws	25-33 in-lbs	3-4 Nm	Page 2-72
Instrument panel screws	30-36 in-lbs	3-4 Nm	Apply several drops of Loctite 243 (blue) to last few threads, metric, Page 2-69
Lower and upper header nuts	72-96 in-lbs	8-11 Nm	Lower first, Page 2-59
Lower belt guard	30-36 in-lbs	3-4 Nm	Page 2-65
Master cylinder cover screws	9-13 in-lbs	1.0-1.5 Nm	Page 2-31
Outboard isolator bolts	30-33 ft-lbs	41-45 Nm	Page 2-73
Rear axle nut	49-51 ft-lbs	67-69 Nm	Page 2-14, 2-58
Rear brake caliper mounting screw, large	18-22 ft-lbs	24-30 Nm	Metric, Page 2-40
Rear brake caliper mounting screw, small	14.5-18 ft-lbs	20-24 Nm	Metric, Page 2-40
Rear brake caliper pad hanger pin	132-180 in-lbs	15-20 Nm	Metric, Page 2-39
Rear brake fastener	72-96 in-lbs	8-11 Nm	Page 2-62
Rear brake reservoir mounting screw	12-15 in-lbs	1.4-1.7 Nm	Page 2-36

ITEM	TORQUE		NOTES
Rear drive sprocket bolts	28-31 ft-lbs	38-42 Nm	Apply several drops of Loctite Thread-locker 271 (red) to last few threads. Page 2-13
Rear fender mounting screws	30-36 in-lbs	3-4 Nm	Page 2-64
Rear isolator-to engine crankcase	32-34 ft-lbs	46-50 Nm	Apply several drops of Loctite 243 (blue) to last few threads, Page 2-74
Rear master cylinder mounting screws	48-72 in-lbs	5-8 Nm	Apply several drops of Loctite 243 (blue) to last few threads, metric, Page 2-36
Rear muffler strap screws	17-19 ft lbs	24-25 Nm	Page 2-59
Rear shock top and bottom bolt	35-40 ft-lbs	47-54 Nm	Page 2-42
Steering head upper triple tree clamp screws (at sliders)	13-16 ft-lbs	18-22 Nm	Loctite Anit-Seize, Page 2-55
Swingarm bolt	24-26 ft-lbs	33-35 Nm	Apply anti-seize to bolt and install, Page 2-58
Swingarm pinch bolt	17-19 ft-lbs	23-26 Nm	Apply several drops of Loctite 243 (blue) to last few threads, Page 2-58
Switch housing screws, right side	12-17 in-lbs	1-2 Nm	Metric, Page 2-43
Valve stem nut	42-44 in-lbs	4.7-5.0 Nm	Page 2-21
Windscreen screws	9-11 in-lbs	1 Nm	Page 2-68

GENERAL

WARNING

Match tires, tubes, air valves and caps to the correct wheel rim. Contact a Harley-Davidson dealer. Mismatching can result in damage to the tire bead, allow tire slippage on the rim or cause tire failure, which could result in death or serious injury. (00023a).

Tire sizes are molded on the sidewall. Rim size and contour are marked on the rim's exterior surface.

Example: **MT 2.5 x 16.0 DOT**

- **MT** designates the rim contour.
- **2.5** is the width of the bead seat measured in inches.
- **16.0** is the normal diameter of the rim in inches, measured at the bead seat diameter.
- **DOT** means that the rim meets Department of Transportation Federal Motor Vehicle Safety Standards.

Refer to [Table 2-5](#).

Table 2-5. Tire Fitment-Tubeless Cast Wheels

WHEEL SIZE & POSITION	CONTOUR & RIM SIZE	RIM VALVE HOLE DIAMETER	DUNLOP RADIAL TIRE SIZE
16 in. – Front	MT 2.5 x 16.0 DOT	0.33 in. (8.38 mm)	100/80 16 K330
16 in. – Rear	MT 2.75 x 16.0 DOT	0.33 in. (8.38 mm)	120/80 16 K330

GENERAL

See [Figure 2-1](#). A unique 17-digit serial or Vehicle Identification Number (VIN) is found on each motorcycle. For a description of each item in the VIN, refer to [Table 2-6](#).

VIN LOCATION: BUELL BLAST

The full 17-digit Vehicle Identification Number (VIN), is stamped on the right side of the steering head and printed on a label located on the right edge of the front tie bar frame bracket.

ABBREVIATED VIN: BUELL BLAST

An abbreviated VIN is stamped into a flat on the left crankcase half at the base of the cylinder.

Example: *KP013000456*

See [Figure 2-1](#), for the complete VIN for the same motorcycle as it appears on the steering head.

NOTE

Always give the full Vehicle Identification Number (VIN) located on the steering head when ordering parts or making an inquiry.

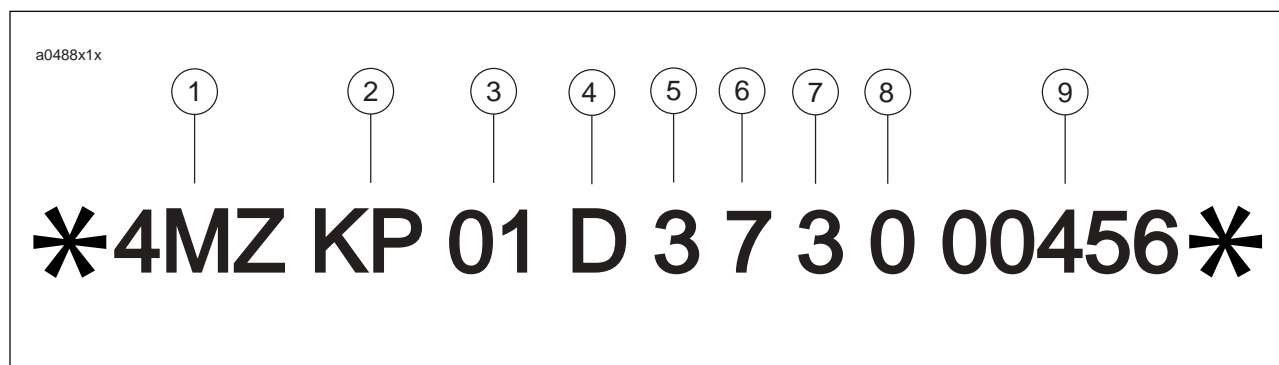


Figure 2-1. 2007 Buell VIN.: Blast (typical)

Table 2-6. 2007 Buell VIN Description

ITEM	DESCRIPTION	POSSIBLE VALUES
1	Market designation (WMI code)	4MZ = Buell vehicles originally manufactured for sale within the United States 5MZ = Buell vehicles originally manufactured for sale outside the United States
2	Motorcycle type code	AX=Firebolt DX=Ulysses JX=Lightning Long KP=Blast KX=Lightning CityX SX=Lightning WX=Lightning Scg
3	Engine	01 492cc 02 984cc 03 1203cc
4	Market configuration	A=Australia L=California N=Canada D=Domestic E=England R=Europe J=Japan
5	VIN check digit	Can be 0-9 or X
6	Model year	7=2007
7	Assembly plant	3=East Troy, WI
8	Model	0=Blast (07) 1=XB9R (07) 2=XB9SX (07) 3=XB12R (07) 4=XB12S (07) 5=XB12Scg (07) 6=XB12Ss (07) 7=XB12X (07)
9	Sequential number (last 5 digits)	Varies

GENERAL

Good handling and maximum tire mileage are directly related to the care of wheels and tires. Regularly inspect wheels and tires for damage and wear. If handling problems occur, refer to [Table 2-7](#).

Keep tires inflated to the recommended air pressure. Always balance the wheel after replacing a tire.

WARNING

Do not inflate tire beyond maximum pressure as specified on sidewall. Over inflated tires can blow out, which could result in death or serious injury. (00027a)

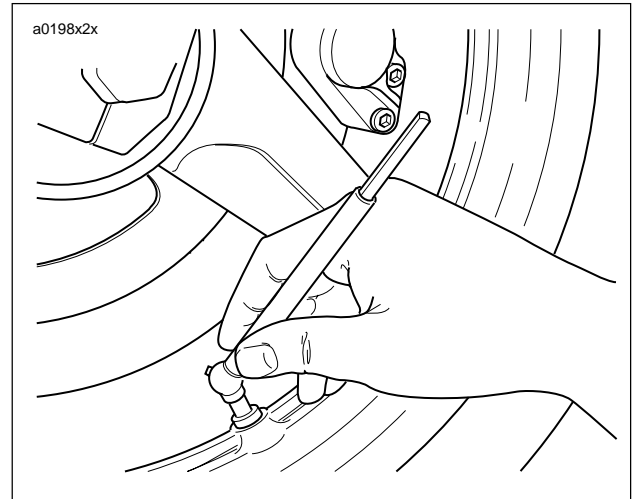


Figure 2-2. Checking Tire Inflation Pressure

TROUBLESHOOTING

See [Figure 2-2](#). Check tire inflation pressure at least once each week. At the same time, inspect tire tread for punctures, cuts, breaks and other damage. Repeat the inspection before long trips.

Table 2-7. Wheel Service

CHECK FOR	REMEDY
Loose axle nuts.	Apply Loctite 243 (Blue) and tighten front axle nut (metric) to 38-42 ft-lbs (52-57 Nm). Tighten rear axle nut (metric) to 49-51 ft-lbs (67-69 Nm).
Excessive side-play or radial (up-and-down) play in wheel hubs.	Replace wheel hub bearings.
Alignment of rear wheel in frame or with front wheel.	Repair swingarm as described under 2.19 SWINGARM .
Rims and tires out-of-true sideways; should not be more than 0.080 in. (2.03 mm).	Replace rims. See 2.9 TIRES .
Rims and tires out-of-round or eccentric with hub; should not be more than 0.090 in. (2.29 mm).	Replace rims. See 2.9 TIRES .
Irregular or peaked front tire wear.	Replace as described under 2.5 FRONT WHEEL or 2.9 TIRES .
Correct tire inflation.	Inflate tires to correct pressure. See 2.2 TIRE SPECIFICATIONS .
Correct tire and wheel balance.	Static balance may be satisfactory if dynamic balancing facilities are not available. However, dynamic balancing is strongly recommended.
Steering head bearings.	Correct adjustment and replace pitted or worn bearings. See 2.18 FORK STEM AND BRACKET ASSEMBLY .
Damper tubes.	Check for leaks. See 2.17 FRONT FORK .
Shock absorber.	Check damping action and mounts. See 2.15 REAR SHOCK ABSORBER .
Swingarm bearings.	Check for looseness. See 2.19 SWINGARM .

 **WARNING**

Use the following guidelines when installing a new tire or repairing a flat. Failure to comply with the guidelines below could result in death or serious injury.

- Always locate and eliminate the cause of the original tire failure.
- Do not patch or vulcanize a tire casing. These procedures weaken the casing and increase the risk of a blowout.

 **WARNING**

Use only Buell approved tires. See a Buell dealer. Using non-approved tires can adversely affect stability, which could result in death or serious injury. (00133a)

 **WARNING**

Tires are a critical safety component. Contact a Buell dealer for tire repair or replacement. Improper tire service can adversely affect stability and handling, which could result in death or serious injury. (00134a)

 **WARNING**

Replace punctured or damaged tires. In some cases, small punctures in the tread area may be repaired from within the demounted tire by a Buell dealer. Speed should NOT exceed 50 m.p.h. (80 km/h) for the first 24 hours after repair, and the repaired tire should NEVER be used over 80 m.p.h. (130 km/h). Failure to follow this warning could result in death or serious injury. (00118a)

 **WARNING**

Buell tires are equipped with wear bars that run horizontally across the tread. When wear bars become visible and only 1/32 in. (0.8 mm) tread depth remains, replace tire immediately. Using a worn tire can adversely affect stability and handling, which could result in death or serious injury. Use only Dunlop Harley-Davidson replacement tires. (00090a)

At regular intervals of 5000 miles (8000 km) or whenever handling irregularities are noted, perform the recommended service checks. See [Table 2-7](#).

If tires must be replaced, same as original equipment tires must be used. Other tires may not fit correctly and may be hazardous to use.

REMOVAL

1. Raise front wheel off floor.
2. Inspect wheel bearing end play and service bearings if necessary. See 2.7 SEALED WHEEL BEARINGS.

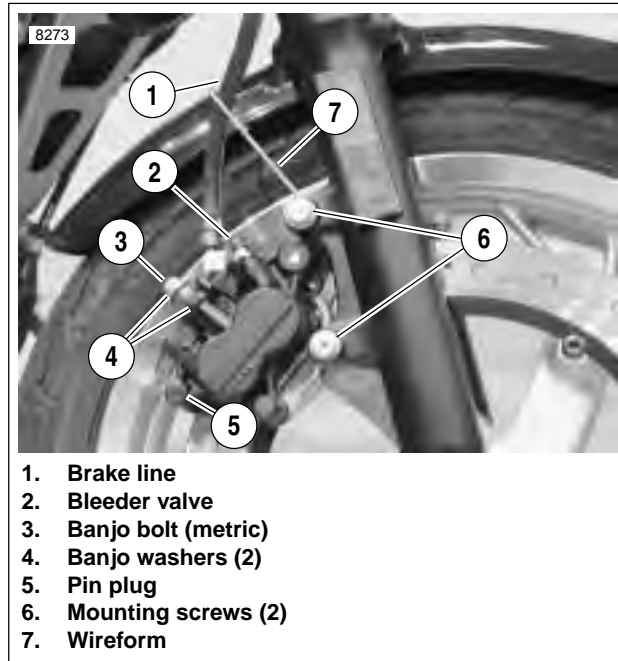


Figure 2-3. Front Brake Caliper

3. Remove brake pads.
 - a. See Figure 2-3. Remove pin plug (4).
 - b. See Figure 2-4. Remove pad hanger pin (metric).
 - c. Remove brake pads from caliper.
4. See Figure 2-3. Detach caliper from mounts.
 - a. Remove lower mounting screw (6).
 - b. Remove upper mounting screw (6) and brakeline wireform (7) while supporting caliper above brake rotor.
 - c. Remove caliper by tilting away from wheel and then pulling away from rotor.

NOTE

Do not operate front brake lever with front wheel removed or caliper pistons may be forced out. Reseating pistons requires caliper disassembly.

5. See Figure 2-5. Insert screwdriver/rod through axle hole (1). Loosen front axle nut (4).
6. Loosen pinch screw (2).
7. Remove front axle nut, spacer and washer. Pull front axle out of wheel hub while supporting front wheel.

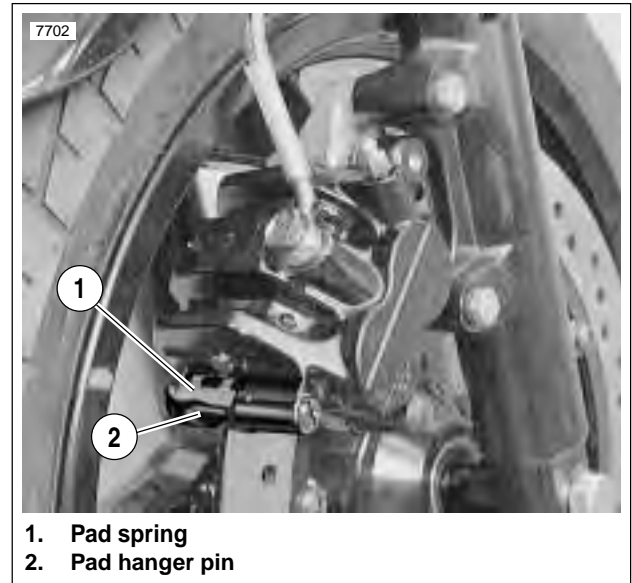


Figure 2-4. Pad Spring

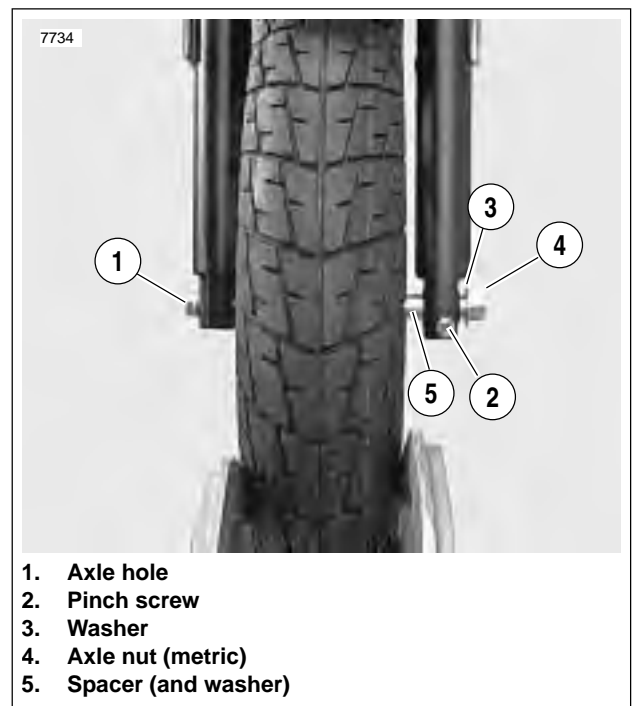


Figure 2-5. Front Wheel Mounting

DISASSEMBLY

1. See [Figure 2-6](#). Remove five bolts (10) and washers (11) to detach front brake rotor (12) from wheel hub. Discard bolts and washers.
2. Remove tire. See [2.9 TIRES](#).

CLEANING AND INSPECTION

1. Thoroughly clean all parts in solvent.
2. Inspect all parts for damage or excessive wear.
3. Inspect brake rotor and pads.

WARNING

Always replace brake pads in complete sets for correct and safe brake operation. Improper brake operation could result in death or serious injury. (00111a)

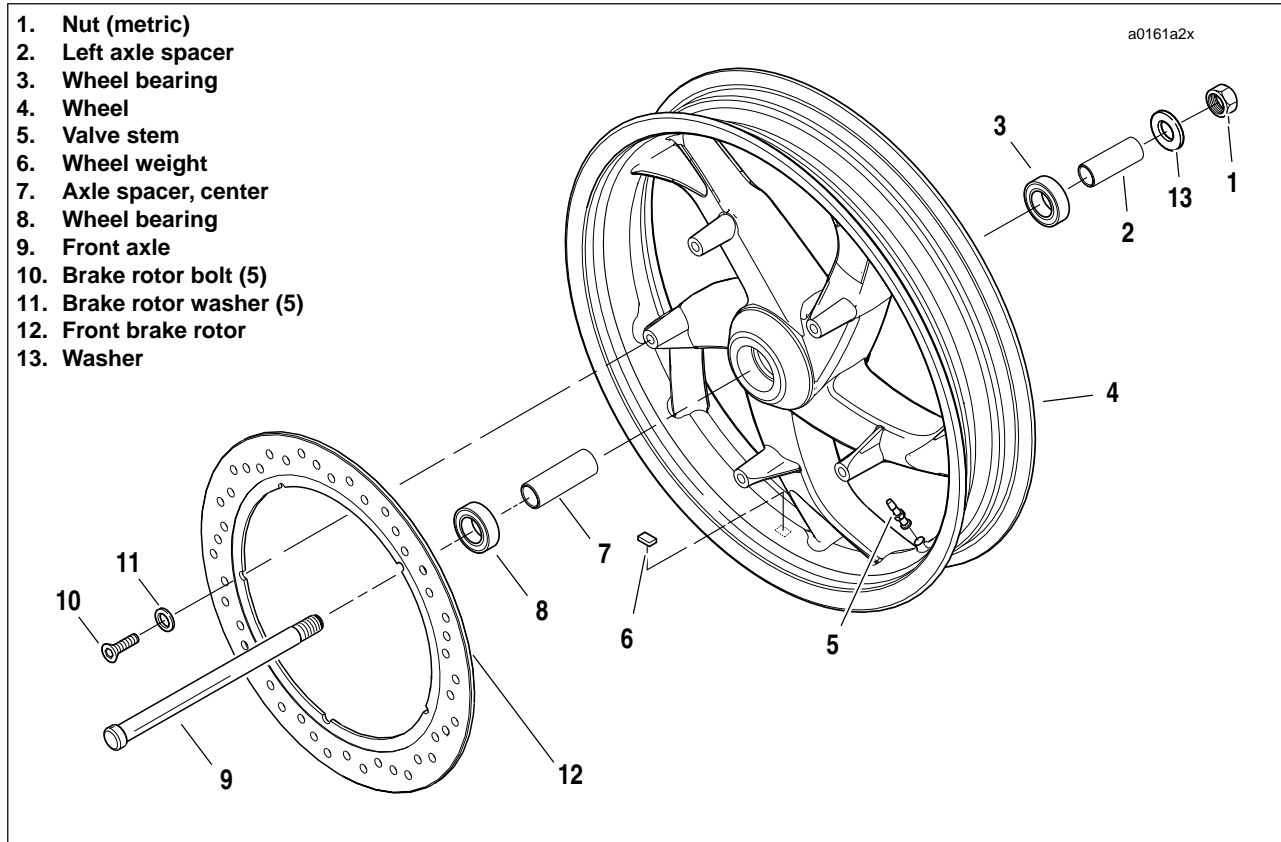


Figure 2-6. Front Wheel Assembly

ASSEMBLY

WARNING

Be sure that brake fluid or other lubricants do not contact brake pads or discs. Such contact can adversely affect braking ability, which could cause loss of control, resulting in death or serious injury. (00290a)

CAUTION

Do not re-use brake disc screws. Re-using disc screws can result in torque loss and damage to rotor and/or brake assembly. (00319b)

1. See [Figure 2-6](#). Install front brake rotor (12) on right side of wheel.
 - a. Verify that the front brake rotor is thoroughly clean.
 - b. Apply Loctite Threadlocker 271 (red) to threads of each of five **new** T40 TORX screws (10).

NOTE

Do NOT reuse brake rotor mounting fasteners (10) and washers (11). Always use **new** washers (P/N CB0004.T) when assembling wheel.

- c. Install rotor (12) on wheel hub. Tighten **new** TORX screws (10) with **new** washers (11) in criss-cross pattern to 24-27 ft-lbs (33-37 Nm).
2. Install tire, if removed. See [2.9 TIRES](#).
 3. Verify that wheel and tire are true. See [2.8 CHECKING CAST RIM RUNOUT](#).
 4. Balance tire. See [2.9 TIRES, ADJUSTMENT](#).

INSTALLATION

1. See [Figure 2-6](#). Install front axle.
 - a. Position wheel between forks with brake rotor on gearcase side of motor.
 - b. With pinch screw (metric) loose, insert threaded end of axle through right side fork.
 - c. Push axle through fork and wheel hub until axle begins to emerge from left side of hub.
 - d. Install axle spacer (2) and washer (13).
2. Compress the front suspension to make sure it is free and not binding.
3. See [Figure 2-6](#). Install axle nut.
 - a. Apply Loctite Threadlocker 243 (blue) to axle threads.
 - b. Install axle nut (1) (metric) over threaded end of axle.
 - c. Insert screwdriver or steel rod through hole in axle.
 - d. While holding axle stationary, tighten axle nut (1) (metric) to 38-42 ft-lbs (52-57 Nm).
4. Tighten the front axle pinch screw to 13-16 ft-lbs (18-22 Nm).
5. Install front brake caliper. See [2.11 FRONT BRAKE CALIPER](#).

REMOVAL

1. Raise rear wheel off floor using REAR WHEEL SUPPORT STAND (Part No. B-41174).
2. Inspect wheel bearing end play and service bearings if necessary. See 2.8 SEALED WHEEL BEARINGS.

NOTE

Do not operate rear brake pedal with rear wheel removed or caliper piston may be forced out. Reseating piston requires caliper disassembly.

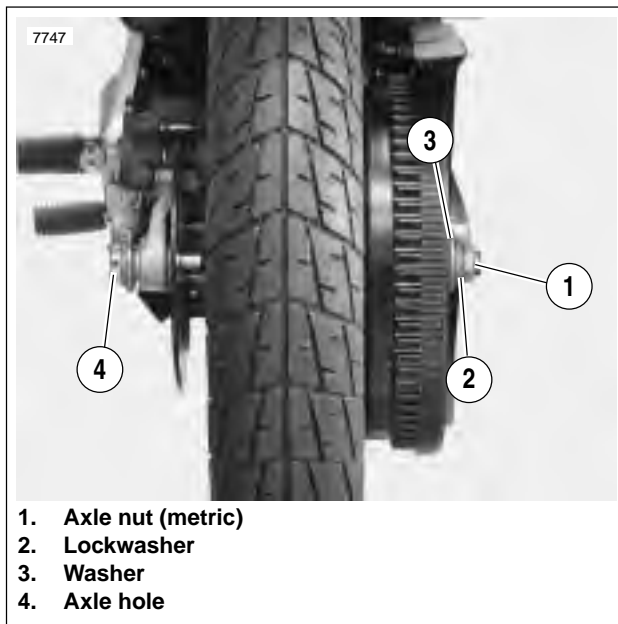


Figure 2-7. Rear Wheel Mounting

3. See Figure 2-7. Place rod or screwdriver through axle hole. Loosen rear axle nut (1) (metric).
4. Remove nut, lockwasher, and flat washer.
5. Pull axle out. Remove right side spacer.
6. Slide carrier with caliper off rotor.
7. Remove left side spacer.
8. Move wheel forward and slide belt off.

DISASSEMBLY

1. See Figure 2-8. Remove and discard five sprocket bolts (6) from sprocket cover.
2. Remove sprocket cover (7) from sprocket.
3. Remove and discard hardened washers from sprocket.
4. Remove sprocket from rear wheel.
5. Remove five T40 TORX screws and brake rotor from rear wheel. Discard screws.

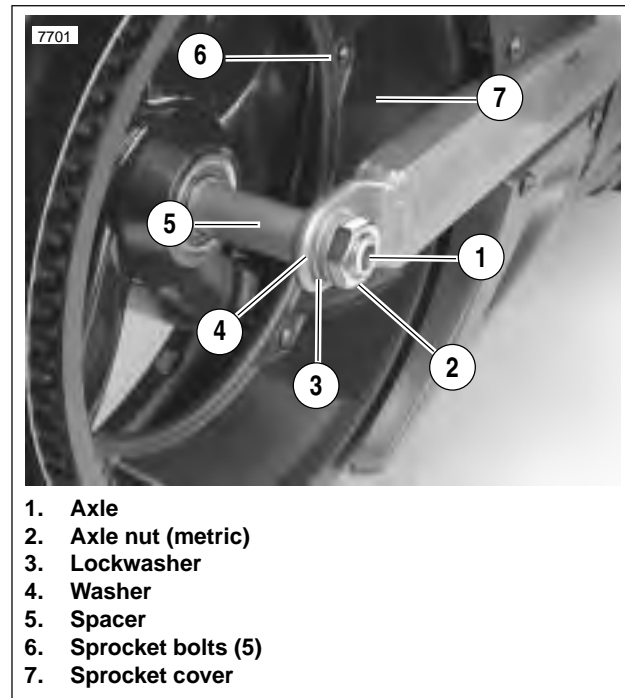


Figure 2-8. Rear Axle, Right Side

CLEANING AND INSPECTION

1. Thoroughly clean all parts in solvent.
2. Inspect all parts for damage or excessive wear.
3. Inspect brake rotor.
 - a. Measure rotor thickness. Replace if less than 4.5 mm. See 2.14 REAR BRAKE CALIPER.
 - b. Check rotor surface. Replace if warped or badly scored.
4. Inspect tire. See 2.9 TIRES.

ASSEMBLY

WARNING

Do not allow brake fluid, bearing grease or other lubricants to contact brake rotor or brake pads or reduced braking ability may occur which could result in death or serious injury.

1. Lay wheel on clean work area with rotor side down.
2. Position sprocket on rim with holes in sprocket and rim aligned.

WARNING

Be sure that brake fluid or other lubricants do not contact brake pads or discs. Such contact can adversely affect braking ability, which could cause loss of control, resulting in death or serious injury. (00290a)

CAUTION

Do not re-use sprocket mounting screws. Re-using sprocket mounting screws can result in torque loss and damage to the sprocket and/or belt assembly. (00480b)

3. Place **new** hardened washers (Part No. BA0511.2Z) on sprocket.
4. Position sprocket cover over washers and install to sprocket with five **new** sprocket fasteners. Tighten fasteners to 28-31 ft-lbs (38-42 Nm).

CAUTION

Do not re-use brake disc screws. Re-using disc screws can result in torque loss and damage to rotor and/or brake assembly. (00319b)

5. See [Figure 2-9](#). Install brake rotor (9) to wheel.
 - a. Verify that the brake rotor is thoroughly clean.
 - b. Apply Loctite Threadlocker 271 (red) to threads of each of five **new** T40 TORX screws (8).
 - c. Install rotor (9) on wheel hub. Tighten **new** TORX screws in criss-cross pattern to 24-27 ft-lbs (33-37 Nm).

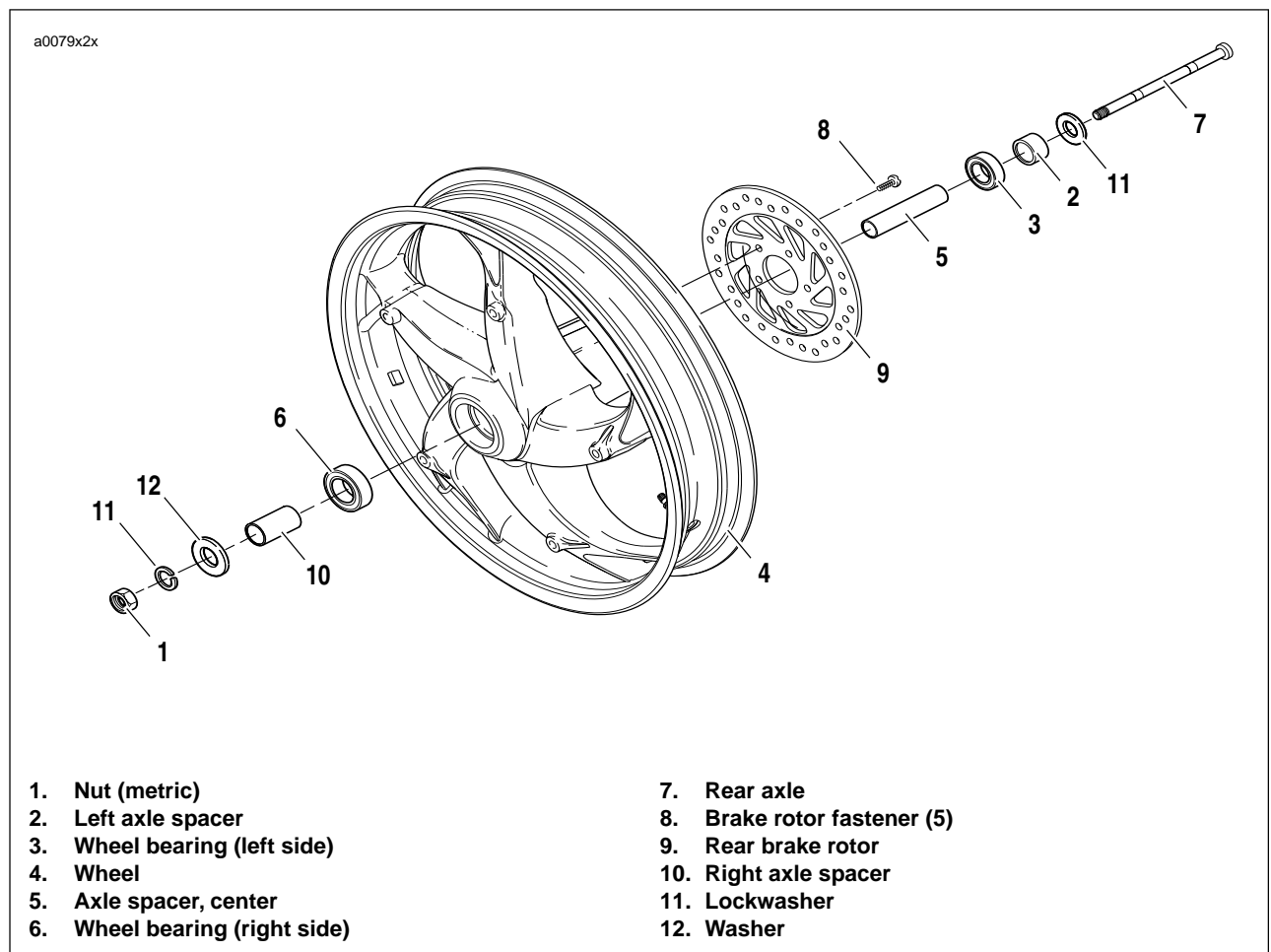


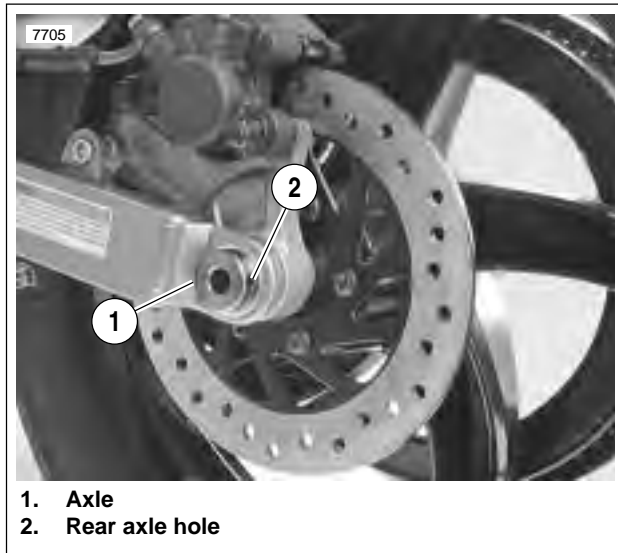
Figure 2-9. Rear Wheel Assembly

INSTALLATION

- Place wheel centrally in the swingarm. Slide wheel far enough forward to slip belt over sprocket and rest belt on sprocket inboard of the teeth.

NOTE

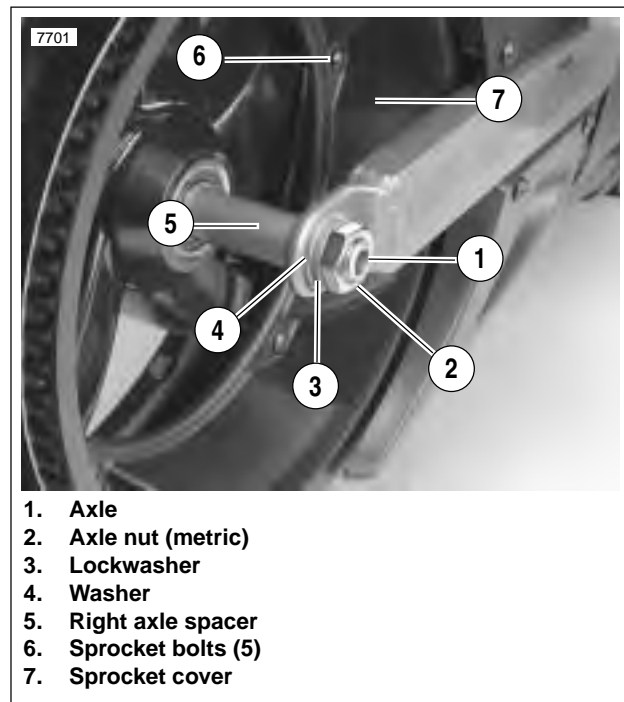
Do not place belt on sprocket teeth at this time. Alignment of parts will be difficult. Resting belt next to teeth allows slack for easier alignment of wheel assembly.



- Axle
- Rear axle hole

Figure 2-10. Rear Axle, Left Side

- See [Figure 2-10](#). Hold left side spacer in place and slide caliper and carrier over rotor.



- Axle
- Axle nut (metric)
- Lockwasher
- Washer
- Right axle spacer
- Sprocket bolts (5)
- Sprocket cover

Figure 2-11. Rear Axle, Right Side

- Slide axle through washer, swing arm, carrier, left side spacer and wheel assembly.
 - See [Figure 2-11](#). Hold right side spacer in place.
 - Insert axle through right side spacer and swingarm.
 - Install flat washer, lockwasher and axle nut.
- Place screwdriver or rod through axle hole and torque rear axle nut to 49-51 ft-lbs (67-69 Nm).
- Slide belt on sprocket teeth by rotating wheel to “walk” belt onto teeth.
- Lower motorcycle rear wheel.

INSPECTION

1. Block motorcycle underneath frame so wheel is raised off the ground.

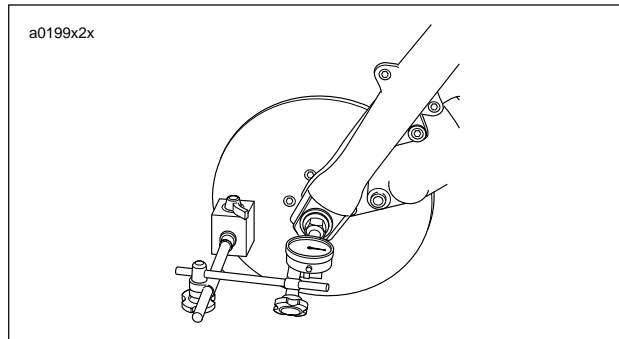
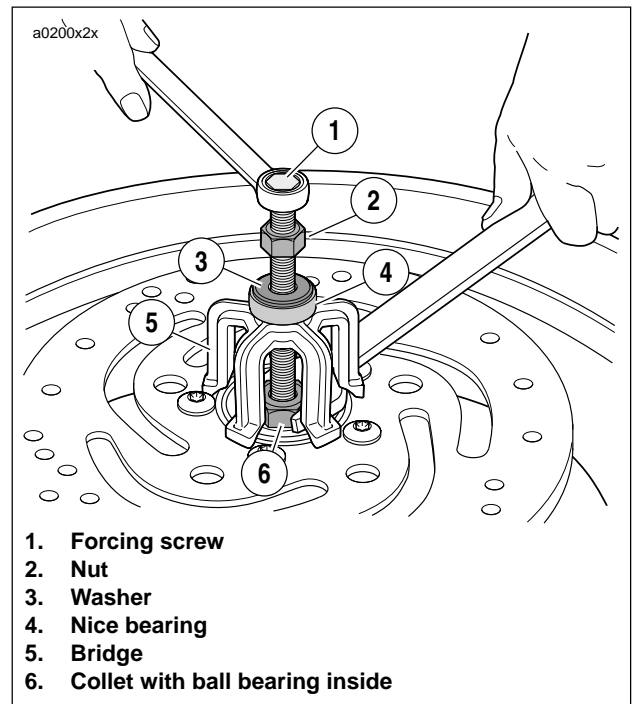


Figure 2-12. Wheel Bearing Inspection (Front Wheel Shown)

2. See [Figure 2-12](#). Mount a magnetic base dial indicator to the brake disc with the dial's contact point on the end of the axle.
3. Turn the wheel through several rotations, then move the wheel side to side to check for lateral end play.
 - a. If the end play is less than the service wear limit of 0.002 in. (0.051 mm), bearing passes inspection.
 - b. If the end play exceeds service wear limit or feels rough, remove wheel and replace both wheel bearings.

REMOVAL

1. Remove wheel from motorcycle. See [2.6 REAR WHEEL](#).



1. Forcing screw
2. Nut
3. Washer
4. Nice bearing
5. Bridge
6. Collet with ball bearing inside

Figure 2-13. Removal Tool

2. See [Figure 2-13](#). Obtain WHEEL BEARING INSTALLER/REMOVER (Part No. B-43933) and assemble.
 - a. Sparingly apply graphite lubricant to threads of forcing screw (1) to prolong service life and ensure smooth operation.
 - b. Install nut (2), washer (3) and Nice bearing (4) on screw. Insert assembly through hole in bridge (5).
 - c. Drop ball bearing inside collet (6). Fasten collet and ball bearing to forcing screw (1).
3. Hold end of forcing screw (1) and turn collet (6) to expand edges of collet.

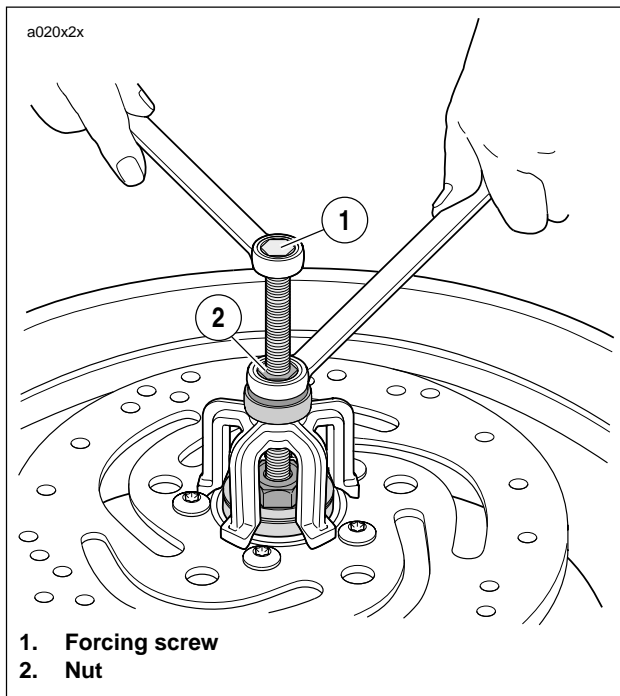


Figure 2-14. Remove Bearing

4. See [Figure 2-14](#). When expanded collet has gripped bearing edges, hold end of forcing screw (1) and turn the nut (2) to remove bearing from wheel.
5. Remove spacer from inside wheel hub.
6. Repeat procedure for opposite side bearing. Discard all bearings upon removal.

INSTALLATION

NOTE

Always install first bearing on primary brake disc side. If front wheel has two brake discs, install bearing on the left side first.

1. Obtain WHEEL BEARING INSTALLER/REMOVER (Part No. B-43933) and assemble.
 - a. Sparingly apply graphite lubricant to threads of threaded rod to prolong service life and ensure smooth operation.
 - b. See [Figure 2-15](#). Place threaded rod through support plate. Insert assembly through wheel.

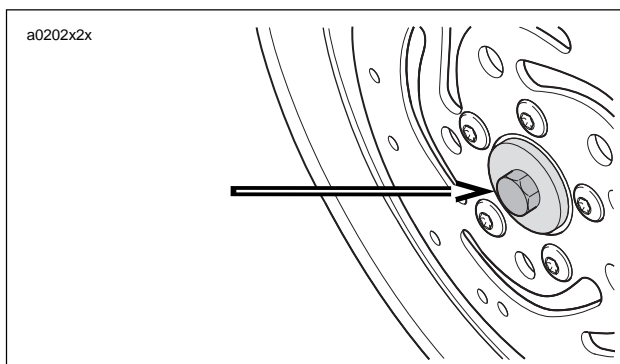


Figure 2-15. Installation Tool Support Plate

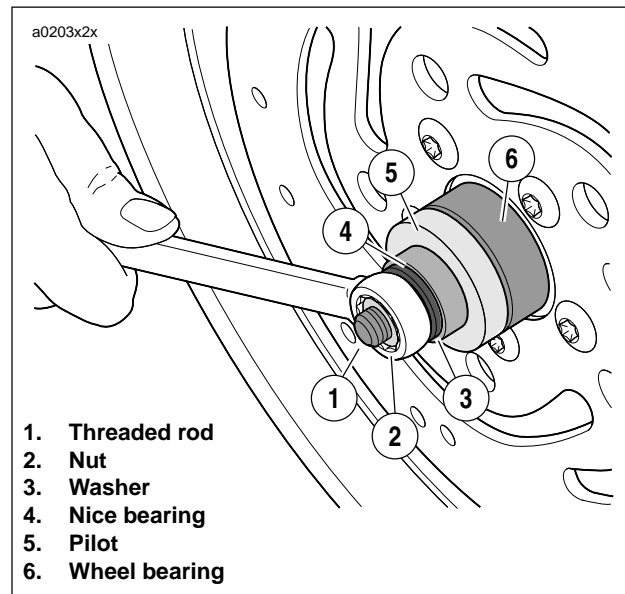
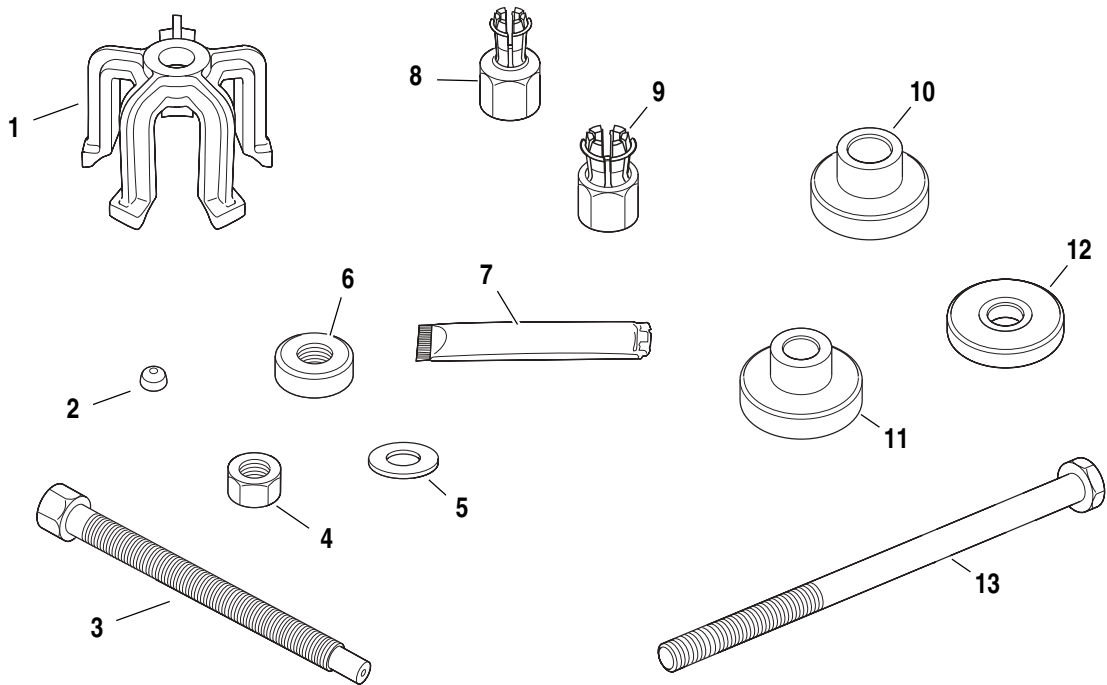


Figure 2-16. Installing Bearing

- c. See [Figure 2-16](#). Place the **new** bearing (6) on rod (1) with lettered side outward.
- d. Install pilot (5), Nice bearing (4), washer (3) and nut (2) over rod.
2. Hold hex end of threaded rod (1) and turn nut (2) to install bearing (6). Bearing will be fully seated when nut can no longer be turned. Remove tool.
3. Install spacer sleeve inside wheel hub.
4. Reverse tool and install opposite side bearing.
5. Tighten bearing tool until bearing inner race contacts spacer.

a0204a2x



1. Bridge (Part No. HD-44060-5)
2. Steel ball (Part No. 12547)
3. Forcing screw (Part No. HD-44060-4)
4. Nut (Part No. 10210)
5. Washer (Part No. 12004)
6. Nice bearing (Part No. RS25100-200)
7. Lubricant (Part No. J-23444A)
8. Collet, 3/4 in. (Part No. B-43993-3)
9. Collet, 1.0 in. (Part No. B-43993-7)
10. Pilot 3/4 in. (Part No. B-43993-6)
11. Pilot 1.0 in. (Part No. B-43993-8)
12. Support plate pilot (Part No. B-43993-1)
13. Threaded rod pilot (Part No. 280856)

Figure 2-17. Wheel Bearing Remover/Installer (Part No. B-43933)

GENERAL

Check wheels for lateral and radial runout before installing a new tire.

Rim Lateral Runout

1. See Figure 2-18. Install truing arbor in wheel hub and place wheel in WHEEL TRUING AND BALANCING STAND (Part No. HD-99500-80).
2. Tighten arbor nuts so hub will turn on its bearings.
3. Check rim lateral runout by placing a gauge rod or dial indicator near the rim bead. Replace wheel if lateral runout exceeds specification shown in Table 2-8.

Rim Radial Runout

1. See Figure 2-19. Install truing arbor in wheel hub and place wheel in WHEEL TRUING AND BALANCING STAND (Part No. HD-99500-80).
2. Tighten arbor nuts so hub will turn on its bearings.
3. Check radial runout as shown. Replace wheel if runout exceeds specification shown in Table 2-8.

Table 2-8. Cast Wheel Runout

MEASUREMENT	in.	mm
MAXIMUM LATERAL RUNOUT	0.040	1.02
MAXIMUM RADIAL RUNOUT	0.030	0.76

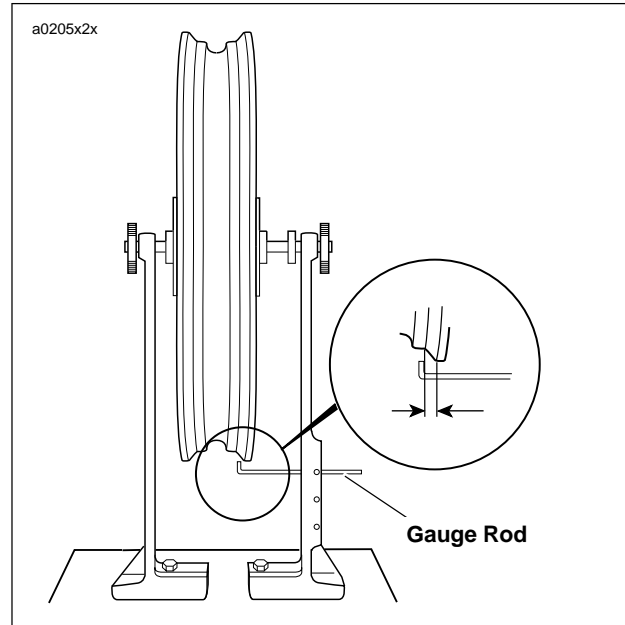


Figure 2-18. Checking Cast Rim Lateral Runout using Wheel Truing and Balancing Stand (Part No. HD-99500-80)

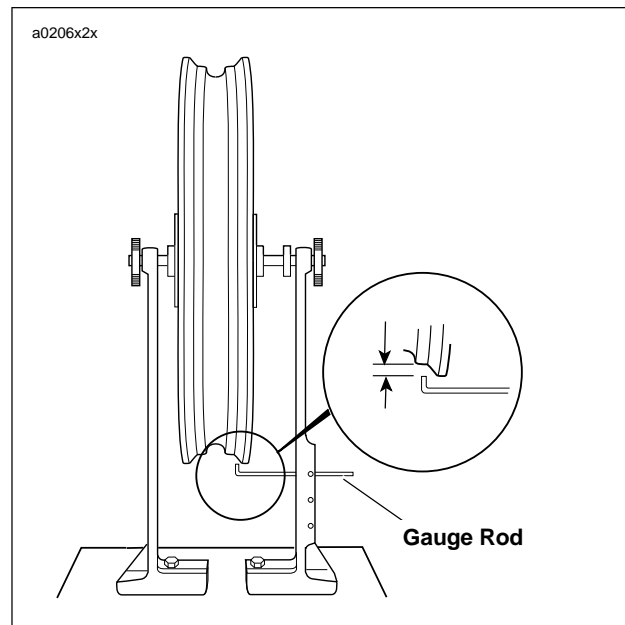


Figure 2-19. Checking Cast Rim Radial Runout using Wheel Truing and Balancing Stand (Part No. HD-99500-80)

GENERAL

Tires should be inspected for punctures, cuts, breaks and wear at least weekly.

New tires should be stored in a horizontal tire rack. Avoid stacking new tires in a vertical stack. The weight of the stack compresses the tires and closes down the beads.

WARNING

Replace punctured or damaged tires. In some cases, small punctures in the tread area may be repaired from within the demounted tire by a Buell dealer. Speed should **NOT** exceed 50 mph (80 km/h) for the first 24 hours after repair, and the repaired tire should **NEVER** be used over 80 mph (130 km/h). Failure to follow this warning could result in death or serious injury. (00118a).

WARNING

Never repair a tire with less than 1/16 in. (1.6 mm) tread depth. Inadequate tread depth can cause an accident which could result in death or serious injury.

WARNING

Use only Buell approved tires. See a Buell dealer. Using non-approved tires can adversely affect stability, which could result in death or serious injury. (00133a)

WARNING

Tires are a critical safety component. Contact a Buell dealer for tire repair or replacement. Improper tire service can adversely affect stability and handling, which could result in death or serious injury. (00134a)

REMOVAL

1. Remove wheel from motorcycle. See [2.5 FRONT WHEEL](#) or [2.6 REAR WHEEL](#).
2. **Rear wheel only:** Remove rear sprocket. See [2.6 REAR WHEEL \(Disassembly\)](#).
3. Deflate tire. Use a valve core tool to remove valve core from valve stem.

WARNING

Read the operating manual for the manufacturer and model of tire machine used. Failure to follow operational procedures or to heed any cautions/warnings in the manual for the tire machine could result in death or serious injury. (00283a)

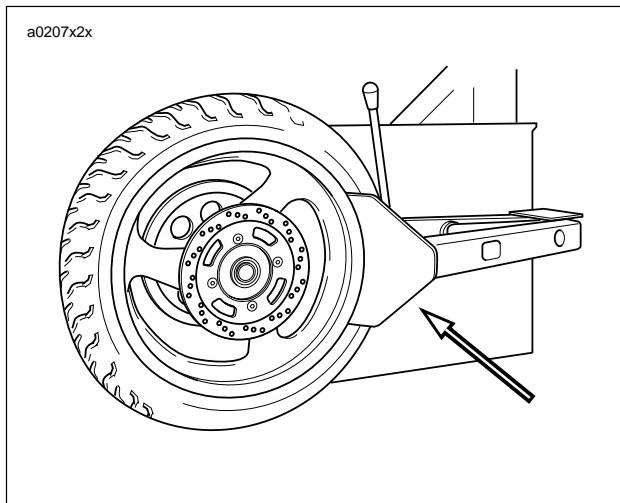


Figure 2-20. Loosening Beads from Rim Flange (Typical)

4. See [Figure 2-20](#). Use a pneumatic bead breaker to loosen bead. Rotate wheel and apply bead breaker at several points along circumference of the rim until entire bead drops into rim well.

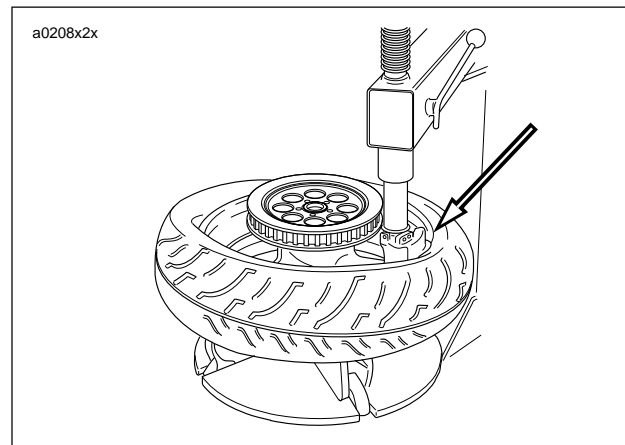


Figure 2-21. Tire Machine Pulling Bead Off Rim

5. See [Figure 2-21](#). Install wheel onto jaws of tire machine. Lubricate tire bead with soap solution.
6. Fit wedge over rim of wheel.
7. Pull bead up over rim in one spot and fit bead to wedge. Spin wheel to draw full length of bead over rim and off wheel. Do not use excessive force when starting bead over rim.

IMPORTANT NOTE

Follow the tire machine manufacture's recommendation for the correct placement of the bead on the mandrel. Incorrect mounting may damage the bead and ruin the tire.

8. If necessary, repeat for opposite bead and remove tire from wheel.
9. Remove valve stem if it is damaged or leaks.
10. Mount tire on TIRE SPREADER (Part No. HD-21000) for inspection and repair procedures.

CLEANING AND INSPECTION

1. Clean inside of tire.
2. If rim is dirty or corroded, clean with a stiff wire brush.
3. Inspect tire for wear and damage. Replace worn tires. See [1.8 TIRES AND WHEELS](#).

INSTALLATION

⚠ WARNING

Only install original equipment tire valves and valve caps. A valve, or valve and cap combination, that is too long or too heavy can strike adjacent components and damage the valve, causing rapid tire deflation. Rapid tire deflation can cause loss of vehicle control, which could result in death or serious injury. (00281a)

⚠ WARNING

Dunlop front and rear tires for Buell motorcycles are not the same. They are not interchangeable. Use front tire **ONLY** for a front tire. **DO NOT** put a rear tire on the front of a vehicle. Failure to follow this warning could result in death or serious injury.

NOTES

- The red circle on the sidewall is a balance mark and should be located next to the valve stem hole.
 - Leaving the valve core out of the valve stem will allow a sufficient volume of air to inflate the radial tire to seat the beads on the rim.
1. Damaged or leaking valve stems must be replaced. Place rubber grommet on valve stem with shoulder in recess of the valve stem head.
 2. Install and tighten nut to 42-44 **in-lbs** (4.7-5.0 Nm).
 3. Thoroughly lubricate bead on both sides of tire with a rubber lubricant. Lubricate inside diameter of bead and side wall. Lubricate rim flanges and safety hump on wheel.

⚠ WARNING

Read the operating manual for the manufacturer and model of tire machine used. Failure to follow operational procedures or to heed any cautions/warnings in the manual for the tire machine could result in death or serious injury. (00283a)

4. With rim installed in pneumatic tire machine jaws, orient tire with rotational arrow pointing in direction of forward rotation. Push one side of bottom bead into rim well and walk the bottom bead around until it is completely in the rim well.

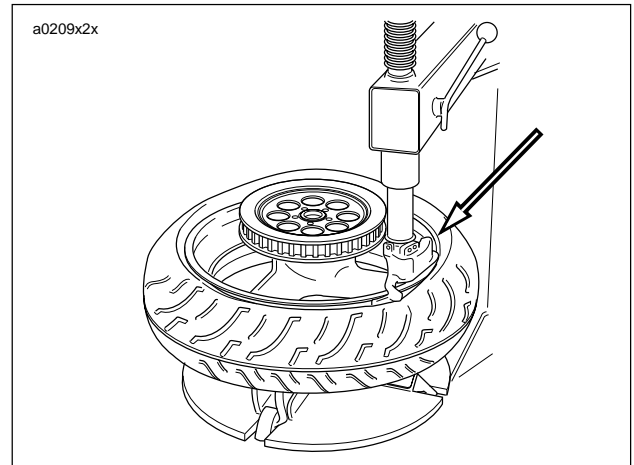


Figure 2-22. Starting Bead on Rim (Typical)

5. See Figure 2-22. Starting at the valve stem, start first bead into the rim well using a tire machine. If no machine is available, work bead on as far as possible by hand. Use a tire tool to pry the remaining bead over rim flange.

⚠ WARNING

Do not use excessive force when starting bead over rim. Excessive force may damage tire or rim and adversely affect handling which could result in death or serious injury.

6. Position red dot at valve stem and starting 180 degrees opposite valve stem, mount top bead to shoe of pneumatic tire machine.
7. Rotate wheel to pull bead into rim well. Remove wheel from tire machine.

⚠ WARNING

Do not exceed manufacturer's recommended pressure to seat beads. Exceeding recommended bead seat pressure can cause tire rim assembly to burst, which could result in death or serious injury. (00282a)

8. Apply air to stem to seat beads on rim. It may be necessary to use a TIRE BEAD EXPANDER (Part No. HD-28700) on the tire until beads seal on rim.

Checking Tire Lateral Runout

1. See [Figure 2-23](#). Turn wheel on axle and measure amount of displacement from a fixed point to tire side-wall.

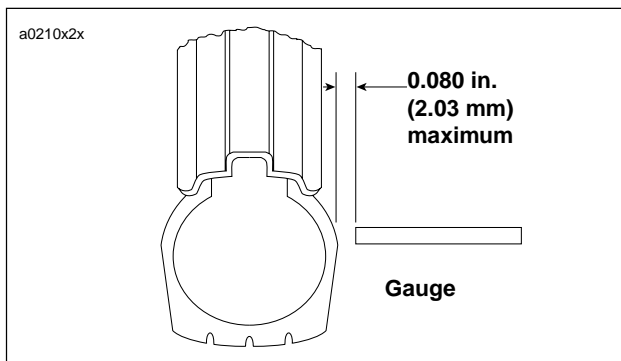


Figure 2-23. Checking Tire Lateral Runout

2. Tire tread lateral runout should be no more than 0.080 in. (2.03 mm). If runout is more than 0.080 in. (2.03 mm), remove tire from rim.
3. Check rim bead side runout. See [2.8 CHECKING CAST RIM RUNOUT](#). Replace rims not meeting specifications.
4. Install tire and check again for tire tread lateral runout.

Checking Tire Radial Runout

1. See [Figure 2-24](#). Turn wheel on axle and measure tread radial runout.

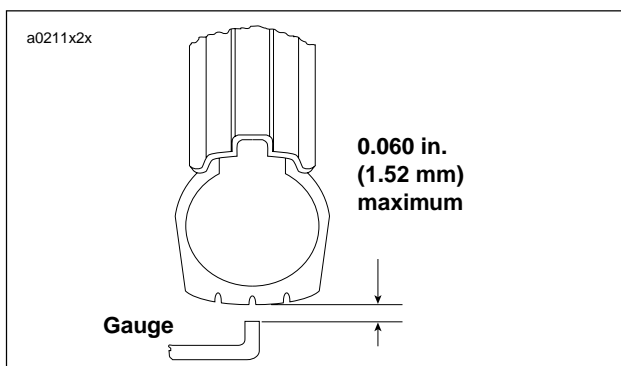


Figure 2-24. Checking Tire Radial Runout

2. Tire tread radial runout should not be greater than 0.060 in. (1.52 mm). If runout exceeds specification, remove tire from rim.
3. Check rim bead runout. See [2.8 CHECKING CAST RIM RUNOUT](#). Replace rims not meeting specifications.
4. Install tire and check tire tread radial runout again.

ADJUSTMENT

Wheel Balancing

Wheel balancing is recommended to improve handling and reduce vibration, especially at high road speeds.

In most cases, static balancing using WHEEL TRUING AND BALANCING STAND (Part No. HD-99500-80) will produce satisfactory results. However, dynamic balancing, utilizing a wheel spinner, can be used to produce finer tolerances for better high-speed handling characteristics. Follow the instructions supplied with the balance machine you are using.

WEIGHTS FOR CAST WHEELS

The maximum weight permissible to accomplish balance is:

- 1.0 oz. (28 g) total weight applied to the front wheel.
- 2.0 oz. (56 g) total weight applied to the rear wheel.

Wheels should be balanced to within 1/4 oz. (7 g) at 60 MPH (97 KM/H).

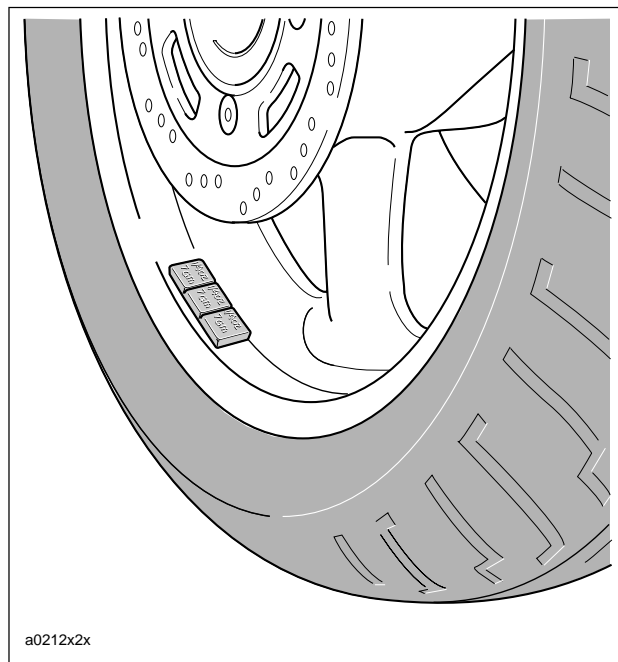


Figure 2-25. Wheel Weights (Typical)

See [Figure 2-25](#). Use only WHEEL WEIGHTS (Part No. 43692-94Y) which have special self-adhesive backings. Apply WHEEL WEIGHTS to the flat surface of the wheel rim.

1. Make sure that area of application is completely clean, dry and free of oil and grease.
2. Remove paper backing from weight. For additional adhesive strength, apply three drops of Loctite Super-Bonder 420 to adhesive side of weight.
3. Place weight on flat surface of wheel rim.
4. Press weight firmly in place and hold for ten seconds.
5. Allow eight hours for adhesive to cure completely before using wheel.

REMOVAL

NOTE

Do not remove the master cylinder unless problems are being experienced.

IMPORTANT NOTE

Always drain brake fluid into a suitable container. Discard used fluid according to local laws.



Figure 2-26. Front Brake Caliper Bleeder Valve (Metric) for Draining Front Brake System

1. See Figure 2-26. To drain brake fluid from front brake system:
 - a. Open bleeder valve (metric) about 1/2-turn.
 - b. Install a length of plastic tubing over caliper bleeder valve. Place free end in a suitable container.
 - c. Pump brake hand lever to drain brake fluid.
 - d. Tighten bleeder valve to 36-60 in-lbs (4-7 Nm).
2. Remove mirror from right handlebar.

IMPORTANT NOTE

Damaged banjo bolt seating surfaces will leak when reassembled. Prevent damage to seating surfaces by carefully removing brake line components.

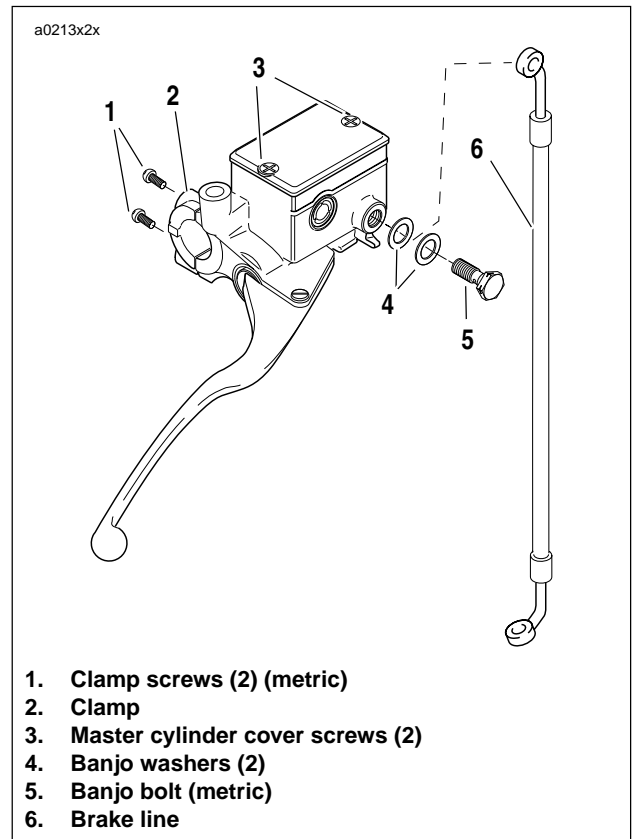


Figure 2-27. Front Master Cylinder

3. See Figure 2-27. Remove banjo bolt (5) (metric) and two banjo washers (4) to disconnect brake line (6) from master cylinder. Discard banjo washers.
4. Unplug both terminals to detach brake lamp switch.

NOTE

The individual parts of the brake lamp switch are not serviceable. Replace switch upon failure.

5. Remove two screws (1) (metric) and clamp (2) to detach master cylinder assembly from handlebar.

DISASSEMBLY

1. See [Figure 2-28](#). Detach front brake hand lever.
 - a. Remove nut (1) (metric) from lever pivot.
 - b. Remove pivot bolt (2) from lever pivot.

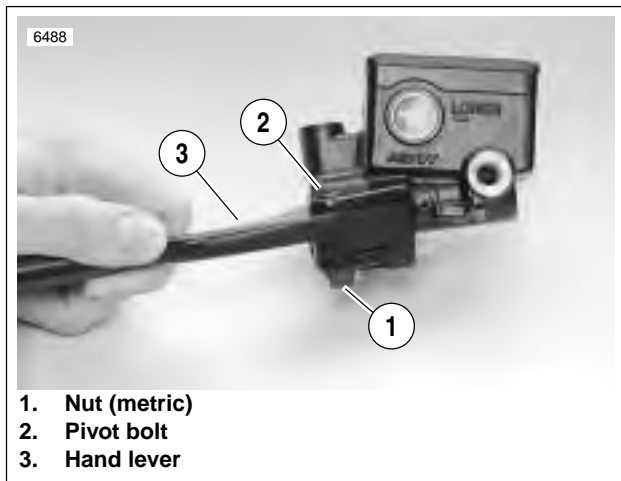


Figure 2-28. Hand Lever

2. Detach front brake hand lever (3) from master cylinder assembly.

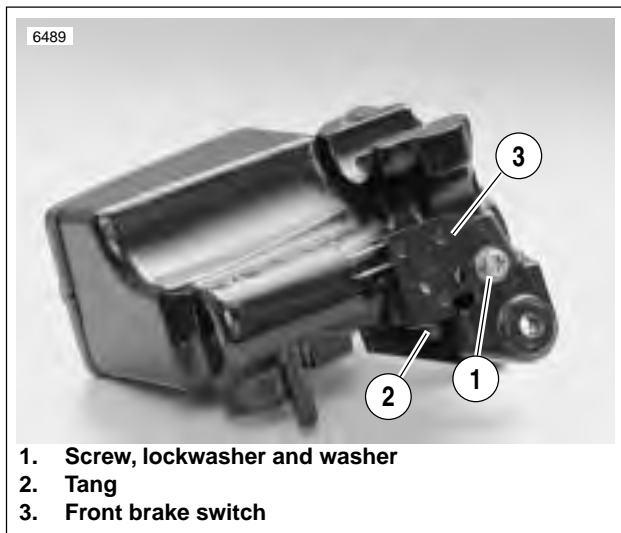


Figure 2-29. Front Brake Switch

3. See [Figure 2-29](#). Remove screw, lock washer and washer (1) holding front brake switch (3) to master cylinder assembly. Remove switch.

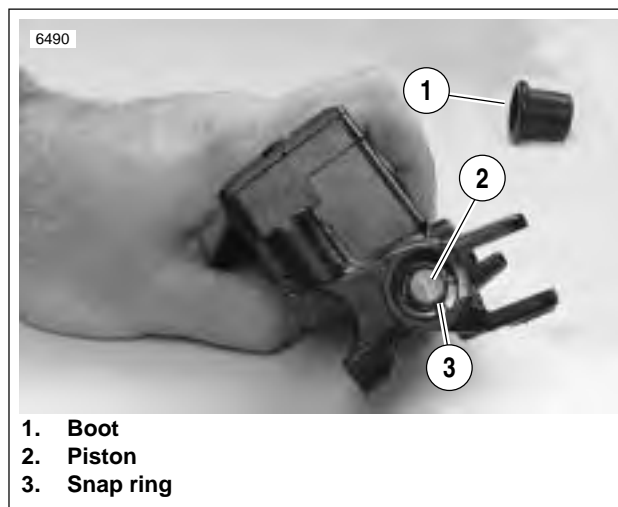


Figure 2-30. Snap Ring

4. See [Figure 2-30](#). Compress piston (2) and remove rubber boot (1).
5. Depress piston assembly and remove internal snap ring (3). Discard snap ring.

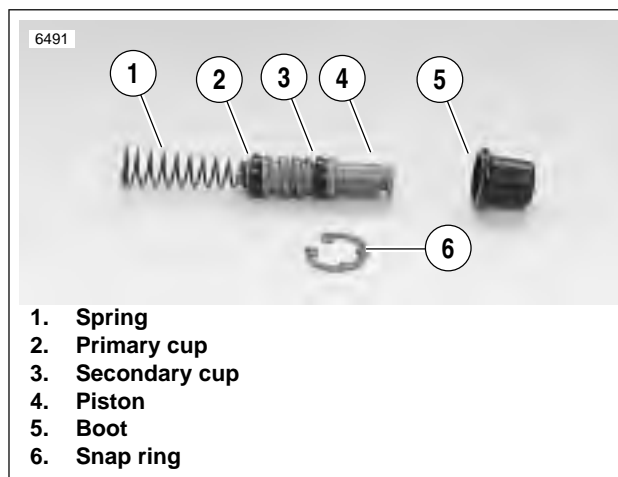


Figure 2-31. Piston Assembly

6. See [Figure 2-31](#). Remove piston assembly (1-4) from front master cylinder.

CLEANING AND INSPECTION

WARNING

Use denatured alcohol to clean brake system components. Do not use mineral-based solvents (such as gasoline or paint thinner), which will deteriorate rubber parts even after assembly. Deterioration of these components can cause brake failure, which could result in death or serious injury. (00291a)

WARNING

Compressed air can pierce the skin and flying debris from compressed air could cause serious eye injury. Wear safety glasses when working with compressed air. Never use your hand to check for air leaks or to determine air flow rates. (00061a)

1. Clean all parts with denatured alcohol or **D.O.T. 4 BRAKE FLUID**. Do not contaminate with mineral oil or other solvents. Wipe dry with a clean, lint free cloth. Blow out drilled passages and bore with a clean air supply. Do not use a wire or similar instrument to clean drilled passages in bottom of reservoir.
2. Carefully inspect all parts for wear or damage and replace as necessary.
3. Inspect piston bore in master cylinder housing for scoring, pitting or corrosion. Replace housing if any of these conditions are found.



Figure 2-32. Master Cylinder Body Outlet Port

4. See [Figure 2-32](#). Inspect outlet port that mates with brake line fitting. As a critical sealing surface, replace housing if any scratches, dents or other damage is noted.
5. Inspect boot for cuts, tears or general deterioration. Replace as necessary.

ASSEMBLY

1. See [Figure 2-33](#). Check piston assembly components.
 - a. Small end of spring (1) sits behind primary cup (2). Large side of primary cup faces spring.
 - b. Secondary cup (3) sits within ridge at middle of piston (4).

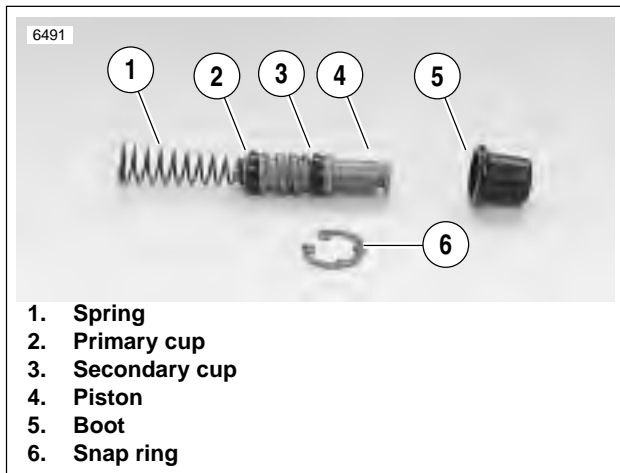


Figure 2-33. Piston Assembly

2. Insert piston assembly, spring first, into master cylinder. Secure with a **new** snap ring (6).
3. Install ridge on boot (5) into groove on piston (4).
4. See [Figure 2-28](#). Install front brake hand lever.
 - a. Align hole in lever with hole in master cylinder assembly.
 - b. Lubricate pivot bolt (2) with Loctite Anti-Seize.
 - c. Install pivot bolt through top of assembly. Tighten to 4-13 **in-lbs** (0.5-1.5 Nm).
 - d. Install nut (1) (metric). Tighten to 44-62 **in-lbs** (5-7 Nm).

5. See [Figure 2-29](#). Install front brake lamp switch (7).
 - a. Attach front brake switch with screw, washer and lockwasher (1). Tighten to 7-13 **in-lbs** (0.8-1.5 Nm).
 - b. See [Figure 2-34](#). Test switch action. Tang (3) on switch must release when hand lever (2) is moved.

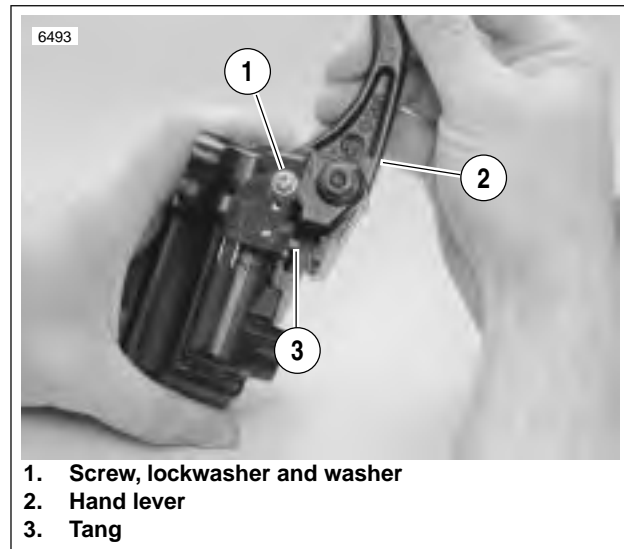


Figure 2-34. Testing Hand Lever

INSTALLATION

- See [Figure 2-27](#). Fasten master cylinder to handlebar by installing clamp (2) and screws (1) (metric). Tighten to 80-120 in-lbs (9-14 Nm).

⚠ WARNING

- Use only new copper banjo washers (See Parts Catalog for Part No.) with D.O.T. 4 brake fluid. Earlier silver banjo washers are not compatible with D.O.T. 4 fluid and will not seal properly over time. Failure to comply may adversely affect braking ability and lead to brake failure which could result in death or serious injury.
 - Avoid leakage. Be sure gaskets, banjo bolt(s), brake line and master cylinder bore are clean and undamaged before assembly. (00322a)
- Connect brake line (5) to master cylinder using two new banjo washers (4) and banjo bolt (6) (metric). Tighten to 16-20 ft-lbs (22-27 Nm).

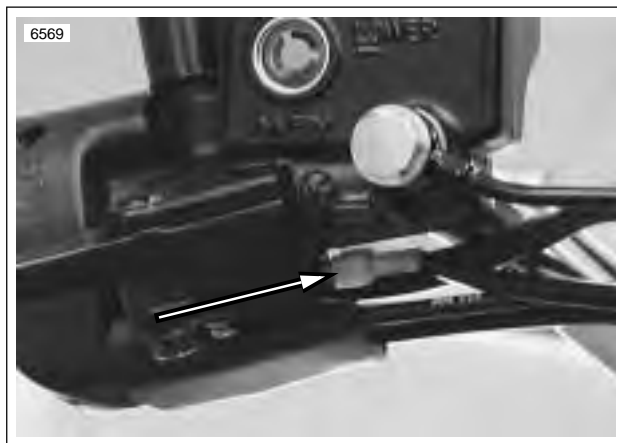


Figure 2-35. Brake Lamp Switch Connectors

- See [Figure 2-35](#). Verify brake lamp switches are secure. Attach wires to switches.
- Install mirror parallel to handlebars.
- See [Figure 2-27](#). Remove the two master cylinder cover screws (3), cover and cover gasket.

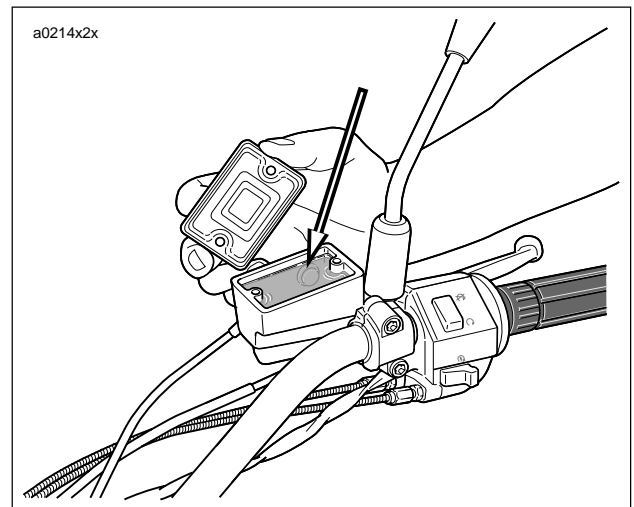


Figure 2-36. Brake Fluid Level

- See [Figure 2-36](#). With the master cylinder in a level position, add **D.O.T. 4 BRAKE FLUID**. Bring fluid level to within 0.125 in. (3.2 mm) of molded boss inside front master cylinder reservoir.

⚠ WARNING

Be sure the master cylinder relief port is not plugged. A plugged relief port can cause brake drag or lockup and loss of vehicle control, which could result in death or serious injury. (00317a)

- See [Figure 2-36](#). Verify proper operation of the master cylinder relief port.
- Actuate the brake lever with the reservoir cover removed. A slight spurt of fluid will break the surface if all internal components are working properly.
- See [Figure 2-27](#). Attach master cylinder cover and cover gasket with the two cover screws (3). Tighten to 9-13 in-lbs (1.0-1.5 Nm).
- Bleed brake system. See [1.6 BRAKE SYSTEM MAINTENANCE](#).

⚠ WARNING

Check for proper brake lamp operation before riding motorcycle. Visibility is a major concern for motorcyclists. Failure to have proper brake lamp operation could result in death or serious injury.

- Turn ignition key switch to IGN. Apply brake hand lever to test brake lamp operation. Turn ignition switch to LOCK.

⚠ WARNING

After repairing the brake system, test brakes at low speed. If brakes are not operating properly, testing at high speeds can cause loss of control, which could result in death or serious injury. (00289a)

REMOVAL

NOTE

Steps 1 and 2 are not required for detaching caliper from rotor. Drain fluid only when disassembling caliper.

IMPORTANT NOTE

Always drain brake fluid into a suitable container. Discard used fluid according to local laws.

1. Drain and discard brake fluid.

IMPORTANT NOTE

Damaged banjo bolt seating surfaces will leak when reassembled. Prevent damage to seating surfaces by carefully removing brake line components.

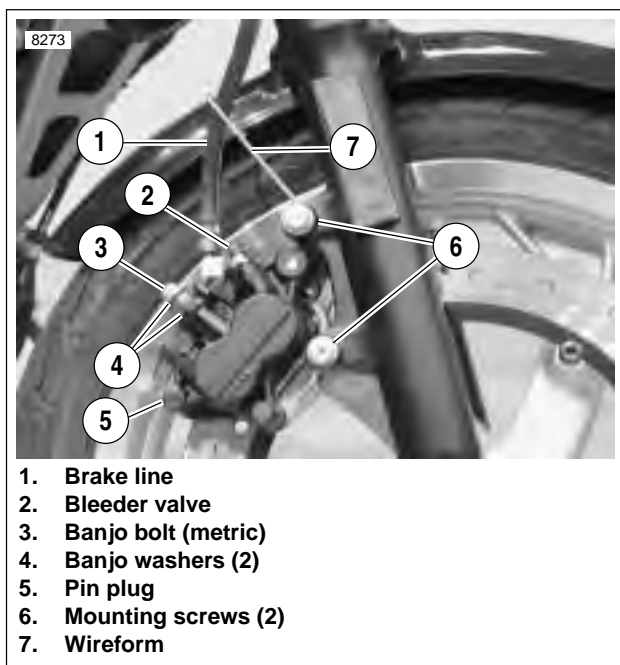


Figure 2-37. Front Brake Caliper

2. See [Figure 2-37](#). Remove banjo bolt (3) (metric) and two banjo washers (4) to disconnect brake line (1) from caliper. Discard banjo washers.

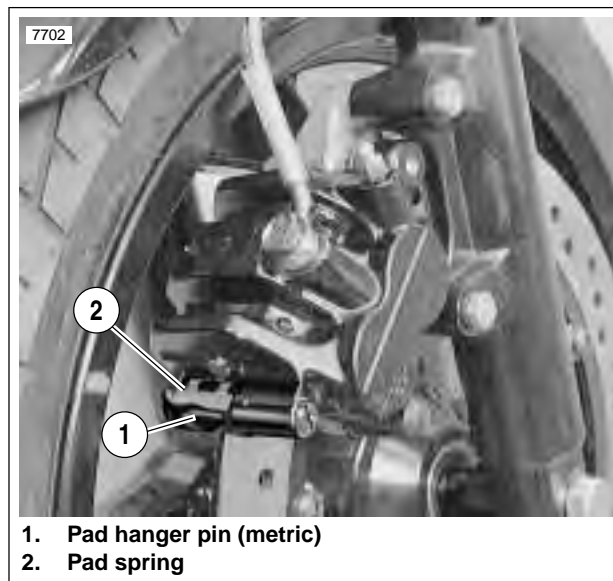


Figure 2-38. Pad Spring

3. Remove brake pads.
 - a. Remove pin plug (5).
 - b. See [Figure 2-38](#). Remove pad hanger pin (1) (metric).
 - c. Remove brake pads from caliper.
4. See [Figure 2-37](#). Detach caliper from mounts.
 - a. Remove lower mounting screw (6).
 - b. Remove upper mounting screw (6) and brake line wireform (7) while supporting caliper above brake rotor.
 - c. Slowly remove caliper by tilting away from wheel and then pulling away from rotor.
 - d. Separate carrier and caliper.

DISASSEMBLY

1. See [Figure 2-39](#). Use BRAKE CALIPER PISTON REMOVER (Part No. B-42887) to pull the two pistons from caliper bores.



Figure 2-39. Removing Pistons

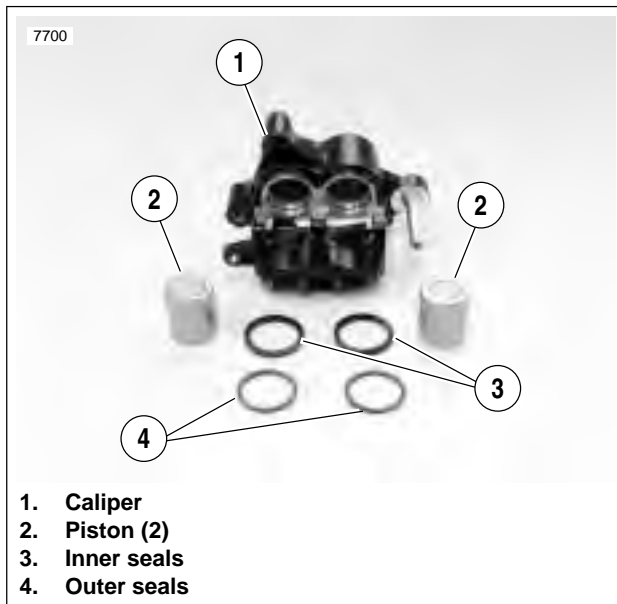


Figure 2-40. Caliper O-rings and Pistons

2. See [Figure 2-40](#). Remove piston outer seals (4) and inner seals (3) from their respective grooves in caliper. Discard seals.
3. Check bleeder valve (metric). Remove and replace if damaged.

CLEANING AND INSPECTION

⚠ WARNING

Use denatured alcohol to clean brake system components. Do not use mineral-based solvents (such as gasoline or paint thinner), which will deteriorate rubber parts even after assembly. Deterioration of these components can cause brake failure, which could result in death or serious injury. (00291a)

⚠ WARNING

Compressed air can pierce the skin and flying debris from compressed air could cause serious eye injury. Wear safety glasses when working with compressed air. Never use your hand to check for air leaks or to determine air flow rates. (00061a)

1. Clean all parts with denatured alcohol or **D.O.T. 4 BRAKE FLUID**. Do not contaminate with mineral oil or other solvents. Wipe dry with a clean, lint free cloth. Blow out drilled passages and bore with a clean air supply. Do not use a wire or similar instrument to clean drilled passages.
2. Carefully inspect all components. Replace any parts that appear damaged or worn. Do not hone caliper piston bore.
3. Inspect brake rotor.
 - a. Measure rotor thickness. Replace if minimum thickness is less than 0.180 in. (4.5 mm).
 - b. Check rotor surface. Replace if warped or badly scored.

⚠ WARNING

Always replace brake pads in complete sets for correct and safe brake operation. Improper brake operation could result in death or serious injury. (00111a)

4. Inspect brake pads for damage or excessive wear. Replace both pads as a set if the friction material of either pad is worn to 0.040 in. (1.0 mm) or less.

ASSEMBLY

1. See [Figure 2-40](#). Install pistons and O-rings.
 - a. Apply a light coat of **D.O.T. 4 BRAKE FLUID** to seals, pistons and caliper piston bores.
 - b. Install two **new** seals (4) in outer grooves of each piston bore.
 - c. Install two **new** seals (3) in inner grooves of each piston bore.
 - d. Install pistons (2) in each piston bore.
2. Install a **new** bleeder valve (metric) if necessary. Tighten to 36-60 **in-lbs** (4-7 Nm).

INSTALLATION

1. Fit front brake caliper on rotor.
 - a. Slide carrier on caliper.
 - b. Slide caliper over front brake rotor without brake pads installed.

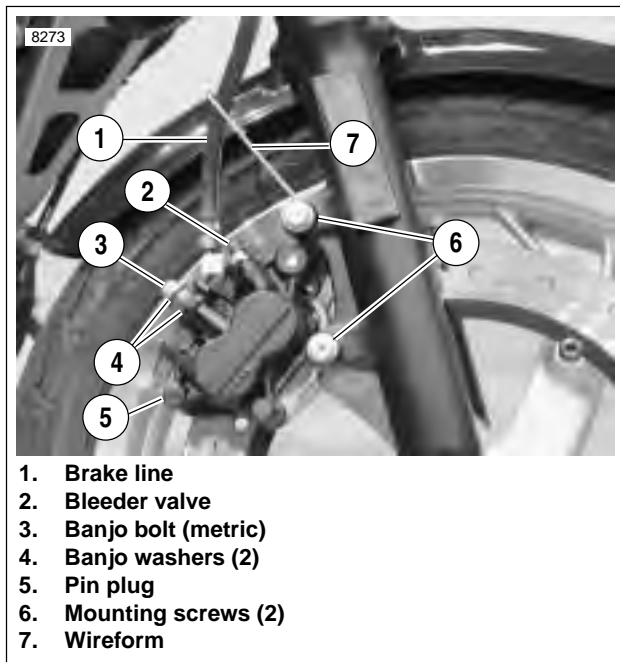


Figure 2-41. Front Brake Caliper

2. See [Figure 2-41](#). Apply Loctite Threadlocker 271 (red) to both caliper mounting screws (6). Install wireform to upper screw and tighten both screws to 18-22 ft-lbs (24-30 Nm).

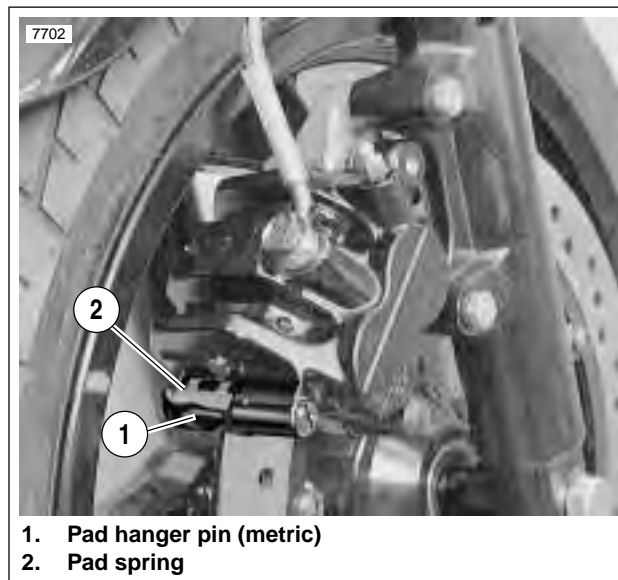


Figure 2-42. Pad Spring

3. See [Figure 2-42](#). Install brake pads.
 - a. Install pad spring (2) with opening at top as shown.
 - b. Insert inboard brake pad from rear of caliper.
 - c. Insert outboard pad.
 - d. See [Figure 2-42](#). Install pad hanger pin (1) (metric). Tighten to 132-180 in-lbs (15-20 Nm).
 - e. See [Figure 2-41](#). Install pin plug (5). Tighten to 18-25 in-lbs (2-3 Nm).

WARNING

Use only new copper banjo washers (See Parts Catalog for Part No.) with D.O.T. 4 brake fluid. Earlier silver banjo washers are not compatible with D.O.T. 4 fluid and will not seal properly over time. Failure to comply may adversely affect braking ability and lead to brake failure which could result in death or serious injury.

IMPORTANT NOTE

To avoid leakage, verify that banjo washers, banjo bolt, hydraulic brake line and caliper bore are completely clean.

4. See [Figure 2-41](#). Connect brake line (1) to caliper using two **new** banjo washers (4) and banjo bolt (3) (metric). Tighten to 16-20 ft-lbs (22-27 Nm).
5. Route brake line through wireform.

IMPORTANT NOTE

Cover molded-in-color surfaces and right handlebar switches and use care when removing brake reservoir cover and adding D.O.T. 4 brake fluid. Spilling D.O.T. 4 brake fluid on molded-in-color surfaces will result in cosmetic damage. Spilling brake fluid on switches can render them inoperative.



1. Master cylinder cover
2. Screws (2)

Figure 2-43. Master Cylinder Cover

6. See [Figure 2-43](#). Remove both master cylinder cover screws (2). Remove master cylinder cover (1) and gasket.
7. With the master cylinder in a level position, verify that the brake fluid level is 0.125 in. (3.2 mm) from molded boss inside reservoir. Add **D.O.T. 4 BRAKE FLUID** if necessary.

⚠ WARNING

Be sure the master cylinder relief port is not plugged. A plugged relief port can cause brake drag or lockup and loss of vehicle control, which could result in death or serious injury. (00317a)

8. Verify proper operation of the master cylinder relief port. Actuate the brake lever with the reservoir cover removed. A slight spurt of fluid will break the surface if all internal components are working properly.
9. See [Figure 2-43](#). Install master cylinder cover (1) and cover gasket with two screws (2). Tighten to 9-13 in-lbs (1.0-1.5 Nm).
10. Depress front brake lever several times to set brake pads to proper operating position within caliper. Bleed brake system.

⚠ WARNING

Be sure that all lights and switches operate properly before operating motorcycle. Low visibility of rider can result in death or serious injury. (00316a)

11. Turn ignition key switch to IGN. Apply brake hand lever to test brake lamp operation. Turn ignition key switch to LOCK.

⚠ WARNING

After repairing the brake system, test brakes at low speed. If brakes are not operating properly, testing at high speeds can cause loss of control, which could result in death or serious injury. (00289a)

NOTE

Avoid making hard stops for the first 100 miles (160 km) to allow **new** brake pads to "wear in" properly with the brake rotor.

REMOVAL

IMPORTANT NOTE

Always drain brake fluid into a suitable container. Discard used fluid according to local laws.

1. Drain and discard brake fluid. See Step 1 under [2.10 FRONT BRAKE MASTER CYLINDER](#).

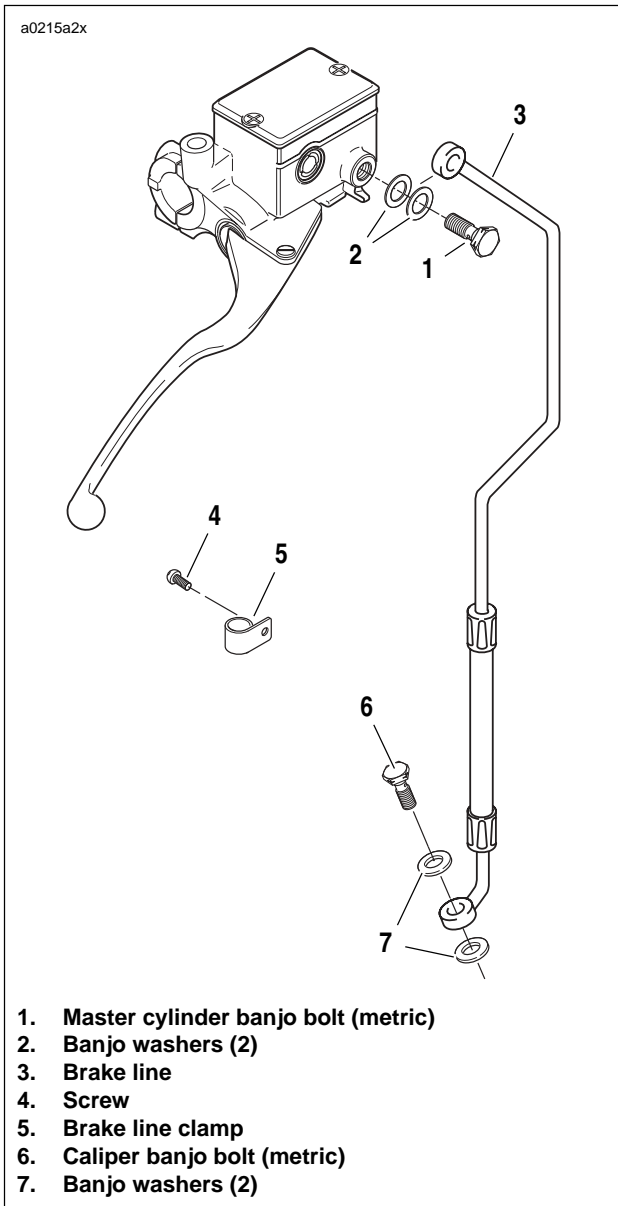


Figure 2-44. Front Brake Line

2. See [Figure 2-44](#). Remove screw (4) to detach brake line clamp (5) from right side of lower triple clamp. Remove brake line from wireform.

IMPORTANT NOTE

Damaged banjo bolt seating surfaces will leak when reassembled. Prevent damage to seating surfaces by carefully removing brake line components.

3. Remove master cylinder banjo bolt (1) (metric) and two banjo washers (2) to disconnect brake line from master cylinder. Discard banjo washers.
4. Remove caliper banjo bolt (6) (metric) and two banjo washers (7) to disconnect brake line from caliper. Discard banjo washers.
5. Carefully inspect the brake line for dents, cuts or other defects. Replace the brake line if any damage is noted.

INSTALLATION

WARNING

Use only new copper banjo washers (See Parts Catalog for Part No.) with D.O.T. 4 brake fluid. Earlier silver banjo washers are not compatible with D.O.T. 4 fluid and will not seal properly over time. Failure to comply may adversely affect braking ability and lead to brake failure which could result in death or serious injury

IMPORTANT NOTE

To avoid leakage, ensure that banjo washers, banjo bolt, hydraulic brake line and master cylinder bore are completely clean.

1. See [Figure 2-44](#). Connect brake line to master cylinder using two **new** banjo washers (2) and banjo bolt (1) (metric). Loosely install bolt into master cylinder.
2. From the master cylinder, the brake line runs downward in front of the right handlebar, where it turns inboard at the upper triple clamp. Loosely install clamp (5) with screw (4) to attach front brake line to right side of lower triple clamp. Position brake line in wireform.
3. Connect brake line to caliper using two **new** banjo washers (7) and banjo bolt (6) (metric). Tighten banjo bolt (6) to 16-20 ft-lbs (22-27 Nm).
4. Tighten clamp screw (4) on lower triple clamp to 36-60 **in-lbs** (4-7 Nm).
5. Tighten master cylinder banjo bolt (1) (metric) to 16-20 lbs (22-27 Nm).
6. Install bleeder valve if removed. Refill master cylinder and bleed brakes.

WARNING

Be sure that all lights and switches operate properly before operating motorcycle. Low visibility of rider can result in death or serious injury. (00316a)

7. Turn ignition key switch to IGN. Apply brake hand lever to test brake lamp operation. Turn ignition key switch to LOCK.

REMOVAL

IMPORTANT NOTE

Always drain brake fluid into a suitable container. Discard used fluid according to local laws.

1. To drain brake fluid from front brake system:
 - a. See [Figure 2-45](#). Remove cap from rear caliper bleeder valve. Open bleeder valve (metric) about 1/2 turn.
 - b. Install a length of plastic tubing over caliper bleeder valve. Place free end in a suitable container.
 - c. Pump brake pedal to drain brake fluid.
 - d. Tighten bleeder valve (metric) to 36-60 **in-lbs** (4-7 Nm). Reinstall cap.

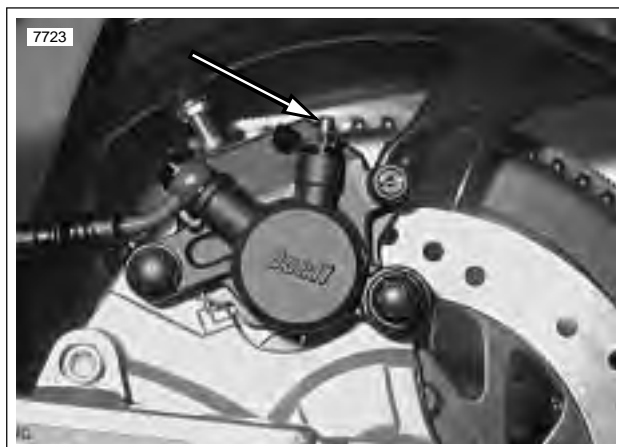


Figure 2-45. Rear Caliper Bleeder Valve (Metric)

IMPORTANT NOTE

Damaged banjo bolt surfaces will leak when reassembled. Prevent damage to seating surfaces by carefully removing brake line components.

2. See [Figure 2-46](#). Remove banjo bolt (3) (metric) and two banjo washers (4) to detach brake line (2) from master cylinder (5). Discard banjo washers.
3. Disconnect push rod (9) from brake pedal clevis (13).
 - a. Spin locknut (12) away from top surface of clevis.
 - b. Turn rod assembly (9) to free rod from clevis (13).

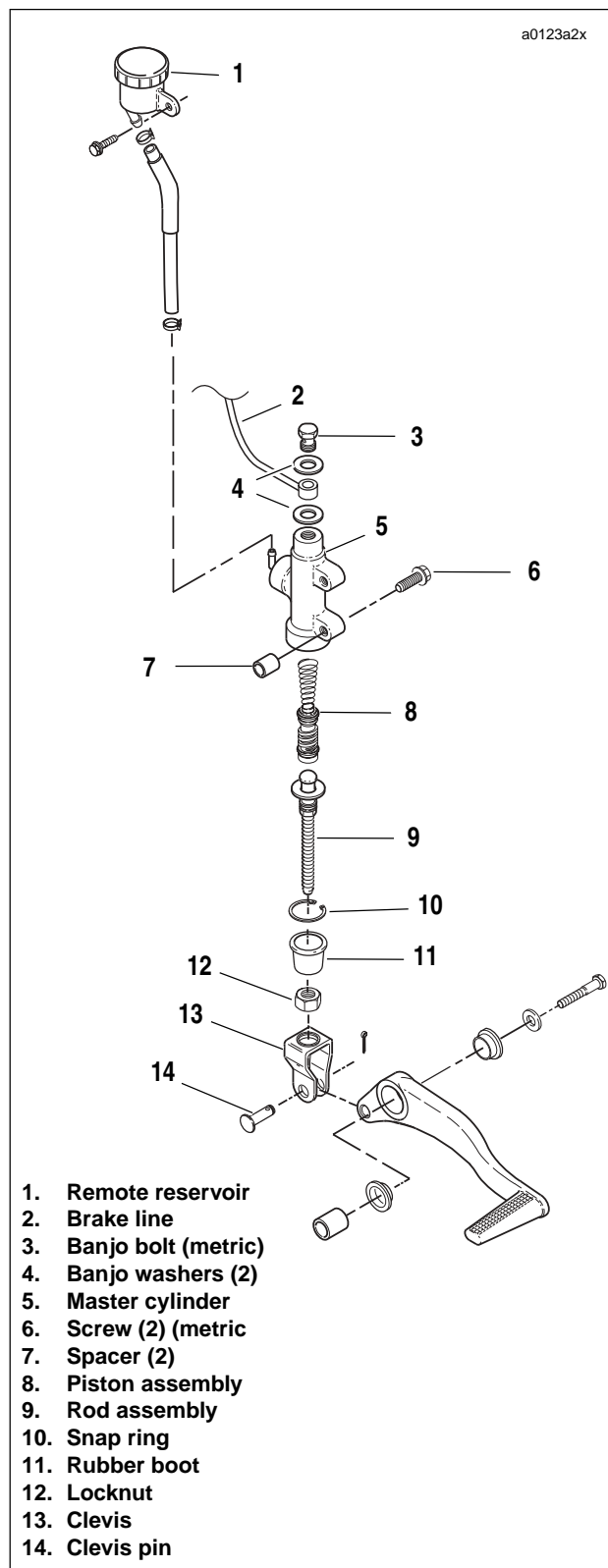


Figure 2-46. Rear Master Cylinder Assembly

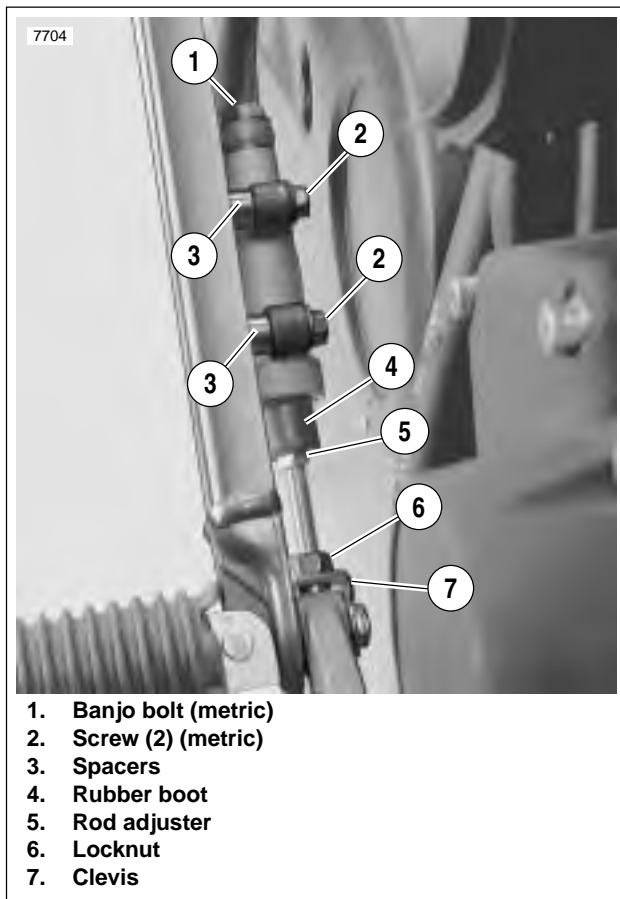


Figure 2-47. Master Cylinder Mounting

4. See [Figure 2-47](#). Remove two screws (2) and spacers (3) to detach master cylinder from footrest support.

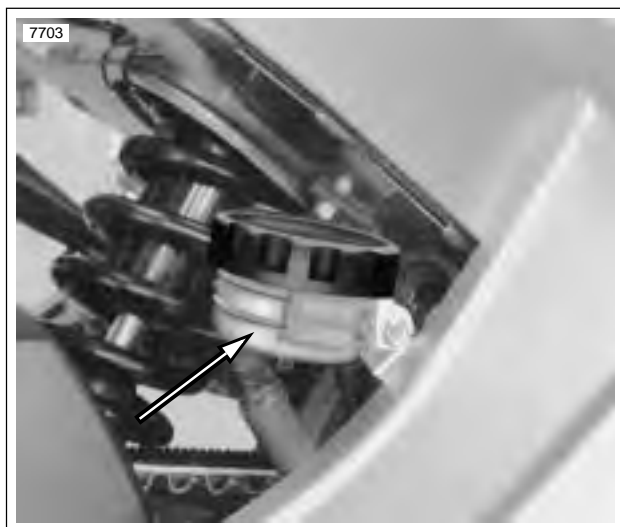


Figure 2-48. Remote Reservoir

5. See [Figure 2-48](#). Detach remote reservoir.

DISASSEMBLY

NOTE

Do not disassemble master cylinder unless problems are experienced. Discard all seals during the disassembly procedure. Install a complete rebuild kit upon assembly.

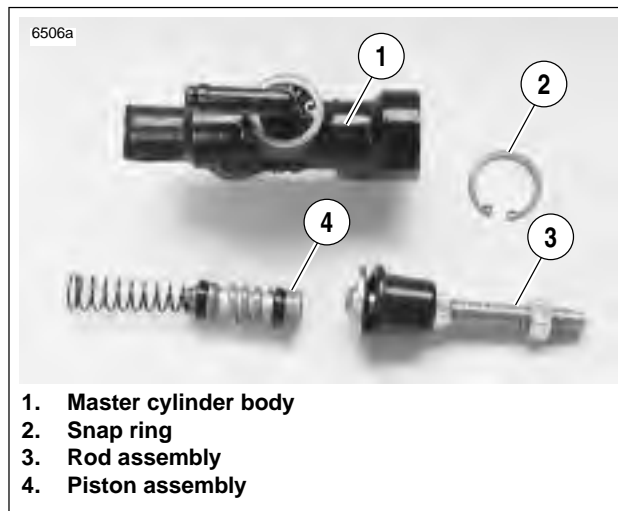


Figure 2-49. Master Cylinder Internals

1. See [Figure 2-49](#). Slide rubber boot on rod assembly (3) away from master cylinder body (1).
2. Depress rod assembly (3) and remove internal snap ring (2). Discard snap ring.
3. Remove piston assembly (4) from master cylinder body.

CLEANING AND INSPECTION

⚠ WARNING

Use denatured alcohol to clean brake system components. Do not use mineral-based solvents (such as gasoline or paint thinner), which will deteriorate rubber parts even after assembly. Deterioration of these components can cause brake failure, which could result in death or serious injury. (00291a)

1. Thoroughly clean master cylinder and all brake system components. Stand master cylinder on wooden block or towel to protect seating surfaces.
 - a. Examine walls of master cylinder reservoir for scratches and grooves. Replace if damaged.
 - b. Verify that vent holes on master cylinder are completely open and free of dirt or debris.
2. Inspect boot on front of master cylinder for cuts, tears or general deterioration. Replace if necessary.

ASSEMBLY

1. See [Figure 2-50](#). Insert piston assembly (4), spring first, into master cylinder.

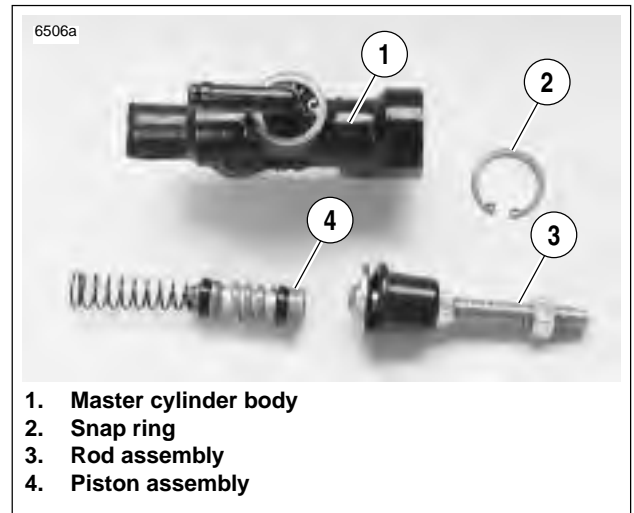


Figure 2-50. Master Cylinder Internals

2. Place round side of rod assembly (3) over piston. Depress piston into master cylinder body (1) and secure with a **new** snap ring (2).
3. Tuck rubber boot on rod assembly (3) into master cylinder body (1).

INSTALLATION

1. See [Figure 2-51](#). Connect remote reservoir.
 - a. If removed, attach remote reservoir to frame using screw. Tighten to 12-15 **in-lbs** (1.4-1.7 Nm).
 - b. If removed, attach reservoir hose to master cylinder with clamp.

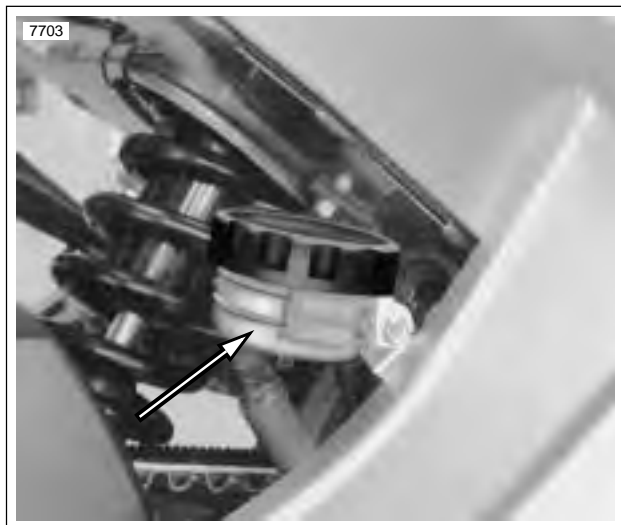


Figure 2-51. Remote Reservoir

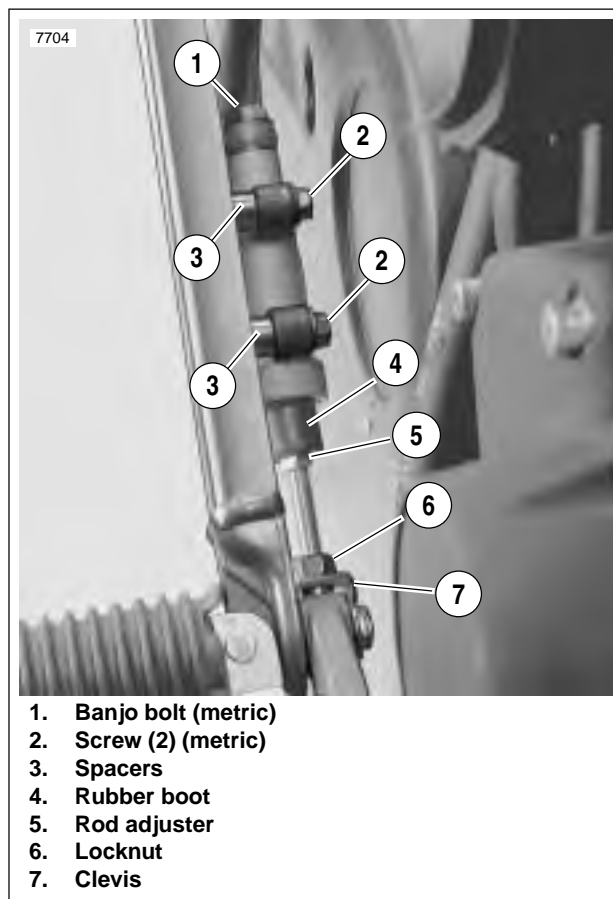
2. See [Figure 2-52](#). Apply Loctite 243 (blue) to both screws. Attach master cylinder to frame with spacers between master cylinder and footrest support. Tighten to 48-72 **in-lbs** (5-8 Nm).

WARNING

Use only new copper banjo washers (See Parts Catalog for Part No.) with D.O.T. 4 brake fluid. Earlier silver banjo washers are not compatible with D.O.T. 4 fluid and will not seal properly over time. Failure to comply may adversely affect braking ability and lead to brake failure which could result in death or serious injury.

WARNING

Avoid leakage. Be sure gaskets, banjo bolt(s), brake line and master cylinder bore are clean and undamaged before assembly. (00322a)



1. Banjo bolt (metric)
2. Screw (2) (metric)
3. Spacers
4. Rubber boot
5. Rod adjuster
6. Locknut
7. Clevis

Figure 2-52. Master Cylinder Mounting

3. See [Figure 2-53](#). Connect brake line (2) to master cylinder (5) with two **new** banjo washers (4) and banjo bolt (3) (metric). Tighten to 16-20 ft-lbs (22-27 Nm).
4. Install push rod (9) by screwing push rod into clevis (13).

NOTE

Brake pedal height should be set so top surface of brake pedal is even with the top surface of the foot peg.

5. See [Figure 2-52](#). Set brake pedal height.
 - a. Loosen locknut (6).
 - b. Turn rod adjuster (5) to obtain correct position.
 - c. Tighten locknut (6).

WARNING

Be sure the master cylinder relief port is not plugged. A plugged relief port can cause brake drag or lockup and loss of vehicle control, which could result in death or serious injury. (00317a)

6. Add brake fluid and bleed brake system.
7. With motorcycle in a level position, check that brake fluid is between the upper and lower marks on reservoir. Add **D.O.T. 4 BRAKE FLUID** if necessary. Be sure gasket and cap on reservoir fit securely.

WARNING

Be sure that all lights and switches operate properly before operating motorcycle. Low visibility of rider can result in death or serious injury. (00316a)

8. Turn ignition key switch to IGN. Apply rear brake pedal to test brake lamp operation. Turn ignition key switch to LOCK.

WARNING

After repairing the brake system, test brakes at low speed. If brakes are not operating properly, testing at high speeds can cause loss of control, which could result in death or serious injury. (00289a)

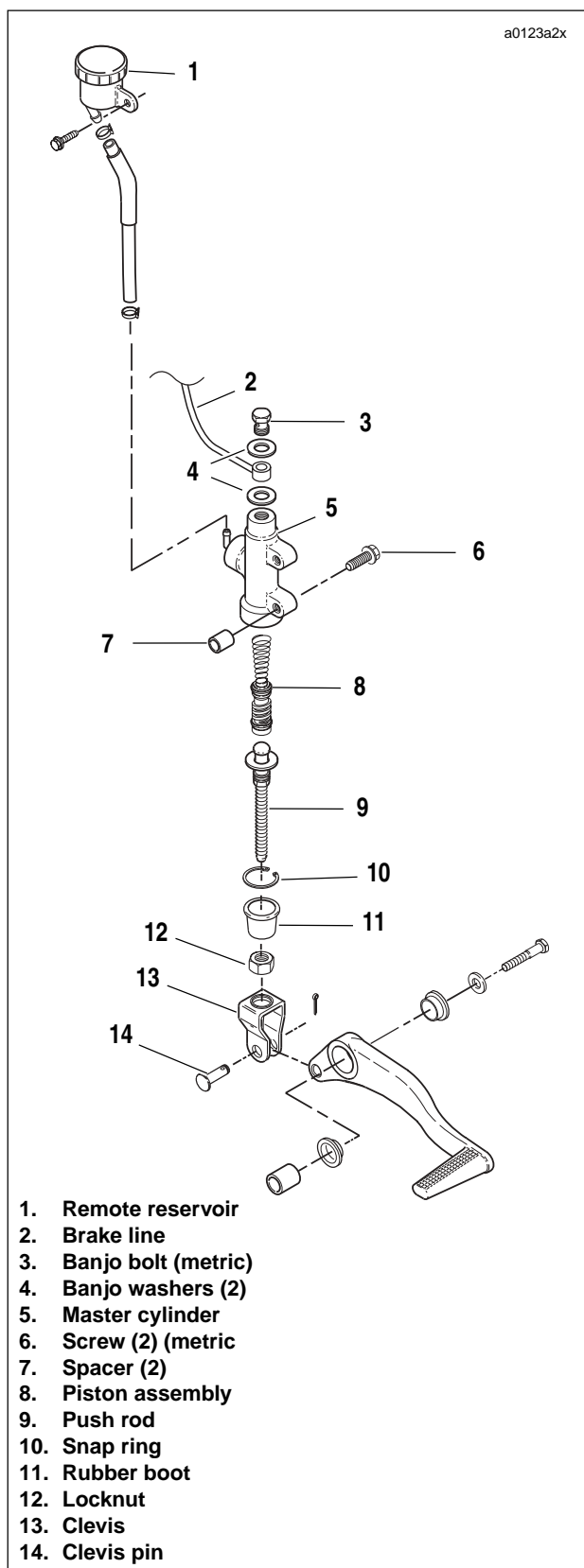


Figure 2-53. Rear Master Cylinder Assembly

REMOVAL

NOTE

Steps 1 and 2 are not required for detaching caliper from rotor. Drain fluid only when disassembling caliper.

IMPORTANT NOTE

Always drain brake fluid into a suitable container. Discard used fluid according to local laws.

1. Drain and discard brake fluid.

IMPORTANT NOTE

Damaged banjo bolt seating surfaces will leak when reassembled. Prevent damage to seating surfaces by carefully removing brake line components.

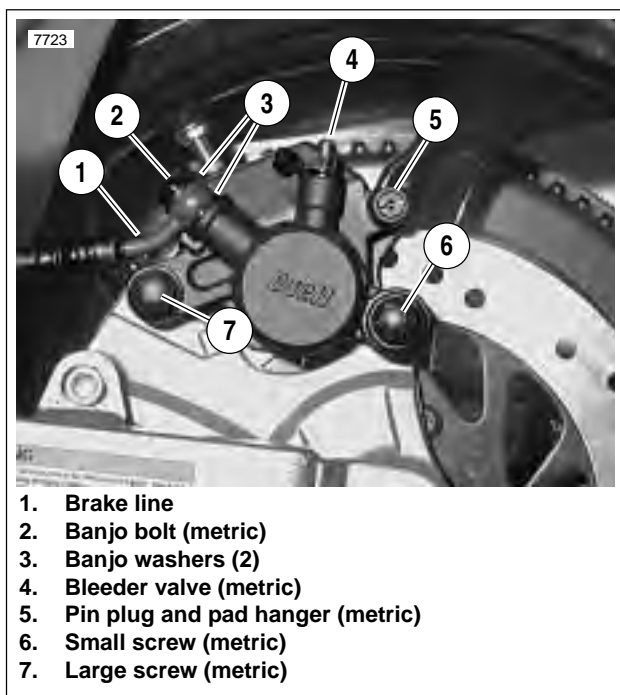


Figure 2-54. Rear Brake Caliper (Typical)

2. See Figure 2-54. Remove banjo bolt (2) (metric) and two banjo washers (3) to disconnect brake line (1) from caliper. Discard banjo washers.
3. Remove small screw (6) (metric) and large screw (7) (metric) to detach caliper from mount.

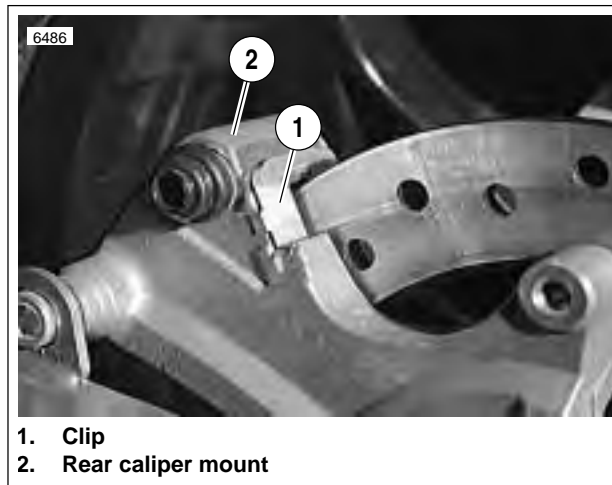


Figure 2-55. Caliper Mount Clip

4. See Figure 2-55. Remove clip (1) from rear caliper mount (2) if necessary.

DISASSEMBLY

1. See Figure 2-54. Remove pin plug and pad hanger (5) (metric) to free brake pads.
2. See Figure 2-55. Remove clip (1) from caliper body.



Figure 2-56. Removing Rear Brake Caliper Piston

3. See Figure 2-56. Remove piston (3) using BRAKE CALIPER PISTON REMOVER (1) (Part No. B-42887) with adaptor (2).
4. Remove two o-rings from groove in caliper bore. Discard o-rings.

CLEANING AND INSPECTION

⚠ WARNING

Use denatured alcohol to clean brake system components. Do not use mineral-based solvents (such as gasoline or paint thinner), which will deteriorate rubber parts even after assembly. Deterioration of these components can cause brake failure, which could result in death or serious injury. (00291a)

1. Clean all parts with denatured alcohol or **D.O.T. 4 BRAKE FLUID**. Do not contaminate with mineral oil or other solvents. Wipe dry with a clean, lint free cloth. Blow out drilled passages and bore with a clean air supply. Do not use a wire or similar instrument to clean drilled passages.
2. Carefully inspect all components. Replace any parts that appear damaged or worn. Do not hone caliper piston bore.
3. Inspect brake rotor.
 - a. Measure rotor thickness. Replace if minimum thickness is less than 0.180 in. (4.5 mm).
 - b. Check rotor surface. Replace if warped or badly scored.

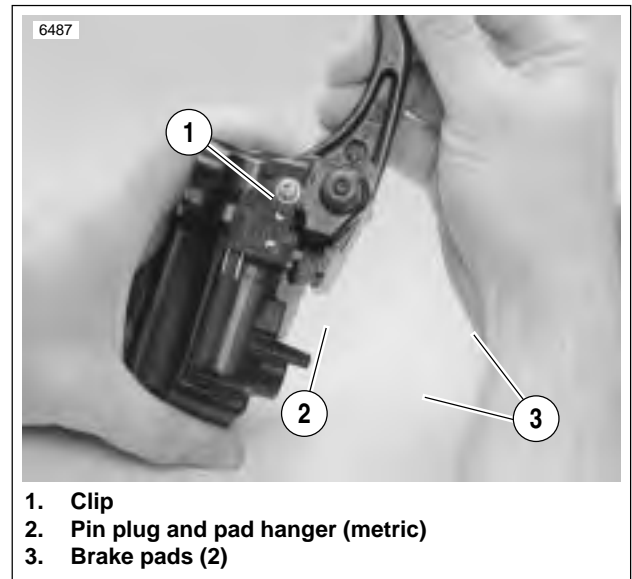
⚠ WARNING

Always replace brake pads in complete sets for correct and safe brake operation. Improper brake operation could result in death or serious injury. (00111a)

4. Inspect brake pads for damage or excessive wear. Replace both pads as a set if the friction material of either pad is worn to 0.040 in. (1.0 mm) or less.

ASSEMBLY

1. See [Figure 2-57](#). Place clip (1) inside caliper body as shown.



1. Clip
2. Pin plug and pad hanger (metric)
3. Brake pads (2)

Figure 2-57. Brake Pads

NOTE

To ensure proper brake pad-to-brake rotor clearance when the caliper is installed, piston must be pressed all the way into the bore whenever **new** brake pads are used.

2. Install pistons and o-rings.
 - a. Apply a light coat of **D.O.T. 4 BRAKE FLUID** to o-rings, piston and caliper piston bore.
 - b. Place two **new** o-rings inside grooves of piston bore.
 - c. Install piston inside caliper body.
3. See [Figure 2-57](#). Install brake pads (3) using pad hanger and pin plug (2).
 - a. Install pad hanger pin (metric). Tighten to 132-180 **in-lbs** (15-20 Nm).
 - b. Install pin plug. Tighten to 18-25 **in-lbs** (2-3 Nm).
4. Install a **new** bleeder valve (metric) if necessary. Tighten to 36-60 **in-lbs** (4-7 Nm).

INSTALLATION

1. See [Figure 2-58](#). Install caliper mount clip (1) if removed.

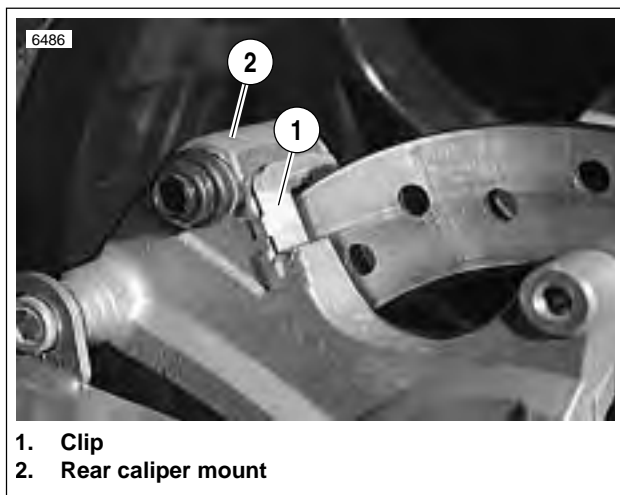


Figure 2-58. Caliper Mount Clip

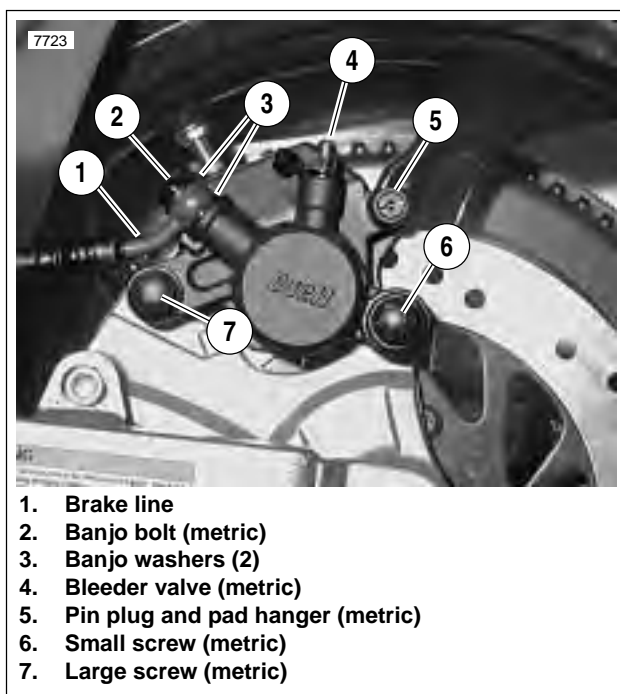


Figure 2-59. Rear Brake Caliper (Typical)

2. See [Figure 2-59](#). Install caliper assembly on caliper mount. Brake pad surfaces must face rear brake rotor.
 - a. Apply Loctite Threadlocker 271 (red) to both caliper mounting screws (6, 7) (metric).
 - b. Install large caliper screw (7) (metric). Tighten to 18-22 ft-lbs (24-30 Nm).
 - c. Install small caliper screw (6) (metric). Tighten to 14.5-18 ft-lbs (20-24 Nm).

⚠ WARNING

Use only new copper banjo washers (See Parts Catalog for Part No.) with D.O.T. 4 brake fluid. Earlier silver banjo washers are not compatible with D.O.T. 4 fluid and will not seal properly over time. Failure to comply may adversely affect braking ability and lead to brake failure which could result in death or serious injury

CAUTION

Avoid leakage. Be sure gaskets, banjo bolt(s), brake line and caliper bore are clean and undamaged before assembly. (00321a)

3. Connect brake line (1) to caliper using two **new** banjo washers (3) and banjo bolt (2) (metric). Tighten to 16-20 ft-lbs (22-27 Nm).
4. Depress rear brake pedal several times to set brake pads to proper operating position within caliper. Bleed brake system.
5. Verify proper fluid level in reservoir.

⚠ WARNING

Be sure that all lights and switches operate properly before operating motorcycle. Low visibility of rider can result in death or serious injury. (00316a)

6. Turn ignition key switch to IGN. Apply brake pedal to test brake lamp operation. Turn ignition key switch to LOCK.

⚠ WARNING

After repairing the brake system, test brakes at low speed. If brakes are not operating properly, testing at high speeds can cause loss of control, which could result in death or serious injury. (00289a)

NOTE

Avoid making hard stops for the first 100 miles (160 km) to allow **new** brake pads to “wear in” properly with the brake rotor.

Table 2-9. Brake Troubleshooting

CONDITION	CHECK FOR	REMEDY
Excessive lever/pedal travel or spongy feel.	Air in system.	Bleed brake(s).
	Master cylinder low on fluid.	Fill master cylinder with approved brake fluid.
Brake fade	Moisture in system.	Bleed brake(s).
		Fill master cylinder with approved brake fluid.
Chattering sound when brake is applied.	Worn pads.	Replace brake pads.
	Loose mounting bolts.	Tighten bolts.
	Warped rotor.	Replace rotor.
Ineffective brake – lever/pedal travels to limit.	Low fluid level.	Fill master cylinder with approved brake fluid, and bleed system.
	Piston cup not functioning.	Rebuild cylinder.
Ineffective brake – lever/pedal travel normal.	Distorted or glazed rotor.	Replace rotor.
	Distorted, glazed or contaminated brake pads.	Replace pads.
Brake pads drag on rotor – will not retract.	Cup in master cylinder not uncovering relief port.	Inspect master cylinder.
	Rear brake pedal linkage out of adjustment.	Adjust linkage.

REMOVAL

NOTE

See [Figure 2-60](#). Damper component (3) cannot be serviced or repaired. If the damper component is leaking or damaged it must be replaced.

1. Lift rear wheel off ground using REAR WHEEL SUPPORT STAND (Part No. B-41174).
2. Remove seat. See [2.28 SEAT](#).
3. Attach lifting straps to motorcycle. Insert lifting straps under frame tubes.
4. Attach lifting straps to a floor hoist placed behind the motorcycle. Raise motorcycle off lift until rear suspension is unloaded.
5. See [Figure 2-60](#). Remove bolt (1) and nut (4) on top mount.
6. While supporting the shock absorber, remove the bolt (1) and nut (4) from the bottom mount.
7. Remove shock absorber assembly.

INSTALLATION

1. See [Figure 2-60](#). Place **new** damper bushings (2) into mounting holes of shock absorber (if not installed).
2. Loosely install bottom bolt and nut.
3. Loosely install top bolt and nut.

NOTE

Torque bolts and nuts from the bolt side only.

4. Tighten bottom bolt to 35-40 ft-lbs (47-54 Nm).
5. Tighten top bolt to 35-40 ft-lbs (47-54 Nm).

WARNING

After installing seat, pull upward on front of seat to be sure it is in locked position. While riding, a loose seat can shift causing loss of control, which could result in death or serious injury. (00070a)

6. Remove lifting straps and install seat. See [2.28 SEAT](#).

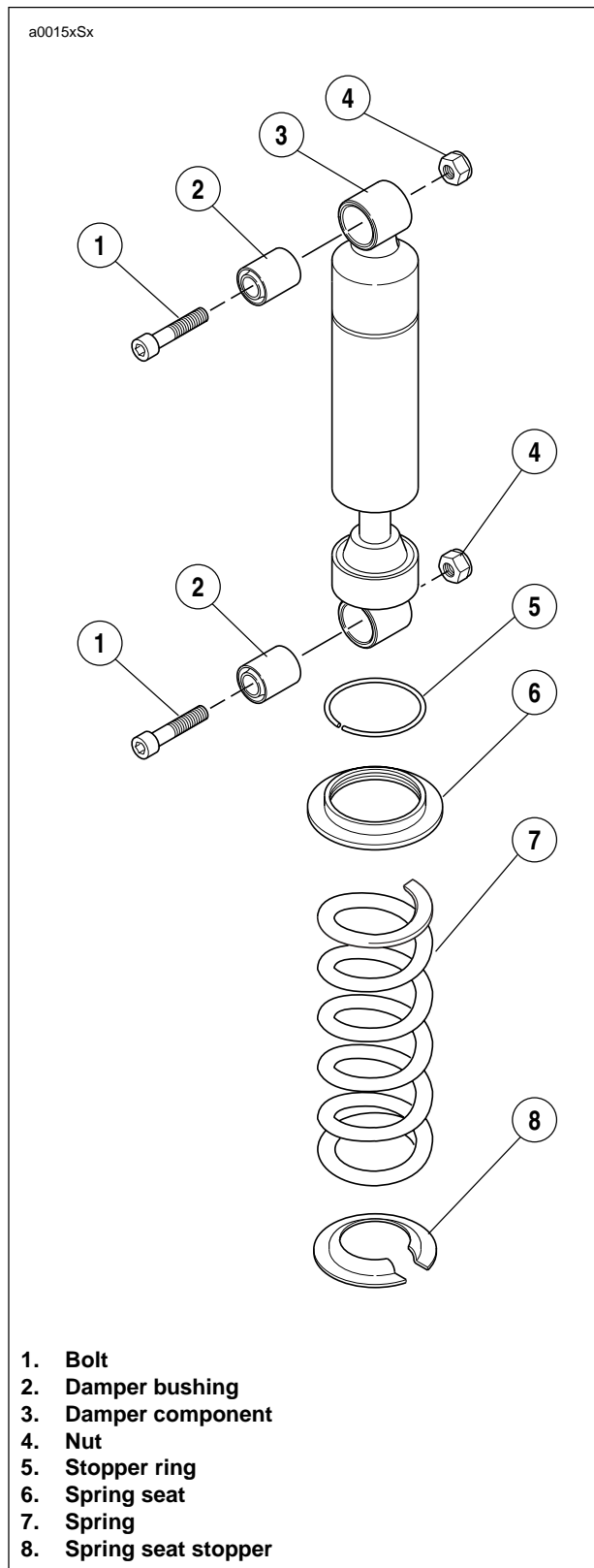


Figure 2-60. Rear Shock Absorber Assembly

REMOVAL/DISASSEMBLY

1. See [Figure 2-61](#). Slide rubber boot off the cable adjusters. Loosen cable adjuster lock on each adjuster.
2. Turn adjusters (4) in direction which will shorten cable housings to minimum length providing freeplay in both cables.
3. See [Figure 2-62](#). Remove two screws on front housing. Separate housings from handlebar.
4. Remove cables from notches in housings.
5. See [Figure 2-62](#). Unhook ferrules from cable wheel.
6. Remove fuel tank assembly. See [4.2 FUEL TANK COVER/FUEL TANK](#).
7. Cut cable ties along frame.
8. Remove throttle cable clamp.
9. Remove cables from throttle.
10. Carefully note the routing of the cables through/around the forks, along the frame backbone and front/rear of handlebars.
11. Pull cables toward the rear.

CLEANING AND INSPECTION

⚠ WARNING

Compressed air can pierce the skin and flying debris from compressed air could cause serious eye injury. Wear safety glasses when working with compressed air. Never use your hand to check for air leaks or to determine air flow rates. (00061a)

Clean all parts in a non-flammable cleaning solvent. Blow dry with compressed air. Replace cables if frayed, kinked or bent.

ASSEMBLY/INSTALLATION

1. Route cables as noted in step number 10.
2. Connect cables at carburetor.
3. Attach throttle cable clamp. Use Loctite 222 (purple) on screw.
4. See [Figure 2-62](#). Position ferrules on cable wheel.
5. Insert idle control into front switch housing.
6. Slide switch housing over throttle.
7. Insert throttle cable into front switch housing.
8. Attach rear switch housing and position housings on right handlebar by engaging locating pin on front housing with hole in handlebar. Attach housings with two screws, installing longer screw on bottom. Tighten to 12-17 in-lbs (1-2 Nm).
9. Adjust cables. See [1.18 THROTTLE CABLES](#).
10. Install fuel tank. See [4.2 FUEL TANK COVER/FUEL TANK](#).

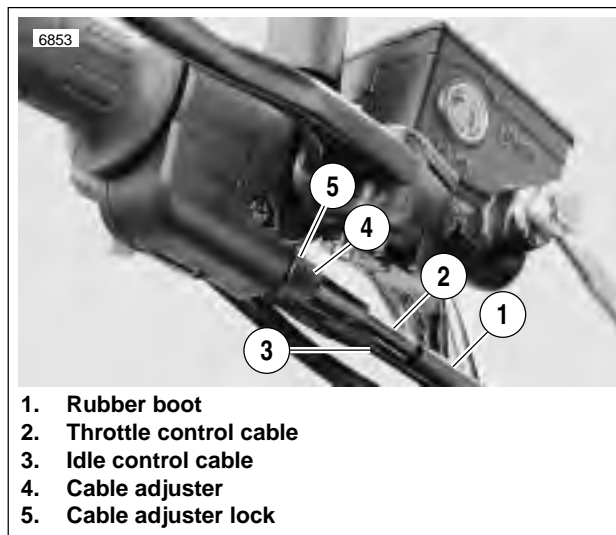


Figure 2-61. Throttle Control Cables

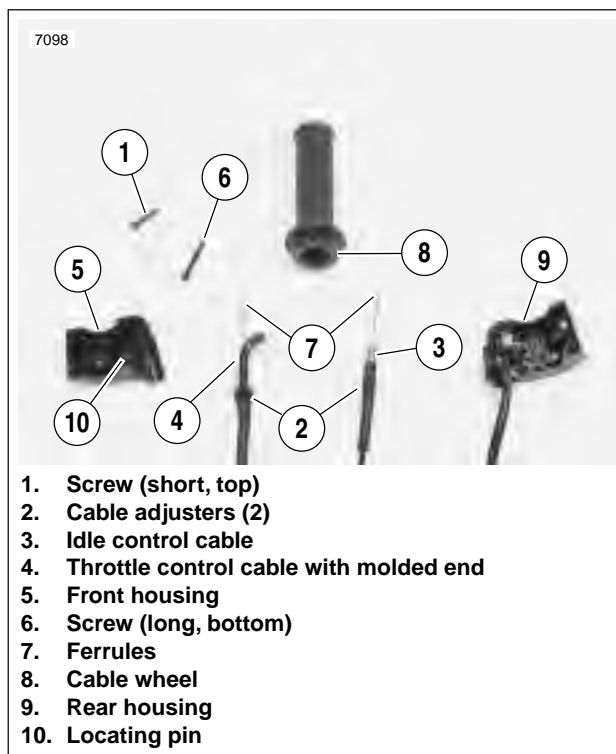


Figure 2-62. Cable Connections

NOTES

GENERAL

See Figure 2-63. The front fork consists of two telescoping outer tube/inner slider assemblies. Each assembly has an internal compression spring which supports the forward weight of the vehicle and rider.

The compression spring extends and retracts to cushion the ride over rough or irregular road surfaces. An oil filled damping mechanism controls the telescoping action of each tube/slider assembly.

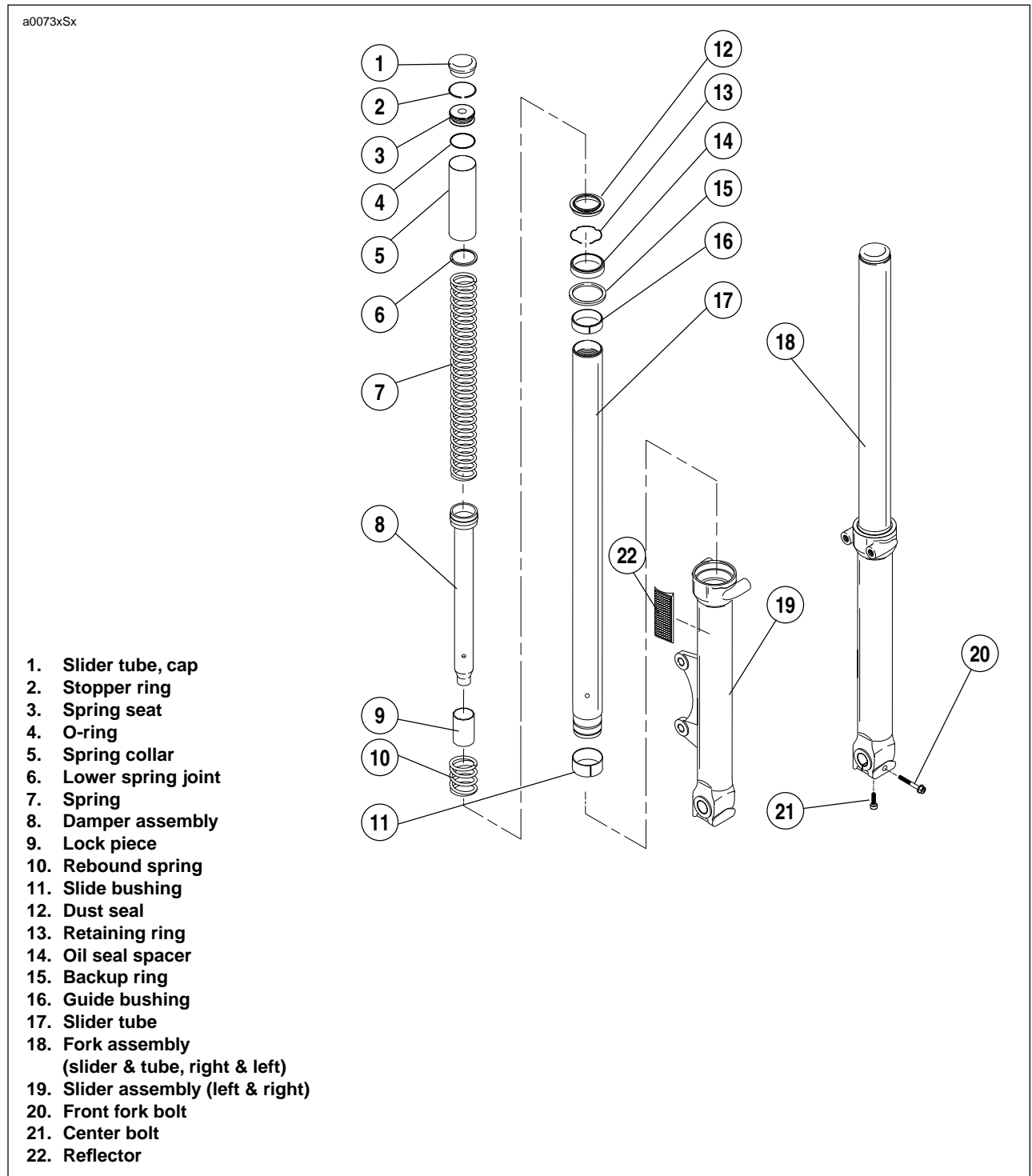


Figure 2-63. Front Fork Assembly

REMOVAL

1. Raise front wheel off floor.
2. Detach front brake caliper from rotor. See [2.11 FRONT BRAKE CALIPER](#).
3. Remove front wheel. See [2.5 FRONT WHEEL](#).
4. Remove front fender. See [2.23 FENDERS](#).
5. See [Figure 2-64](#). Loosen headlamp bracket screws.
6. See [Figure 2-65](#). Loosen the large pinch screws on both the upper and lower triple clamps.
7. See [Figure 2-66](#). Remove front fork. Repeat procedure for the other front fork.

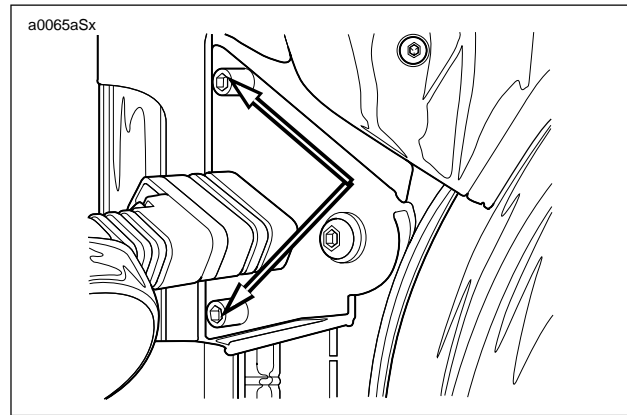


Figure 2-64. Headlamp Bracket Screws



Figure 2-65. Upper and Lower Triple Clamp Pinch Screws



Figure 2-66. Front Fork Removal

DISASSEMBLY

1. Remove front forks.



Figure 2-67. Clamping the Fork

2. See [Figure 2-67](#). Clamp the fork in a vise with front fork holding tool (Part No. B-41177).



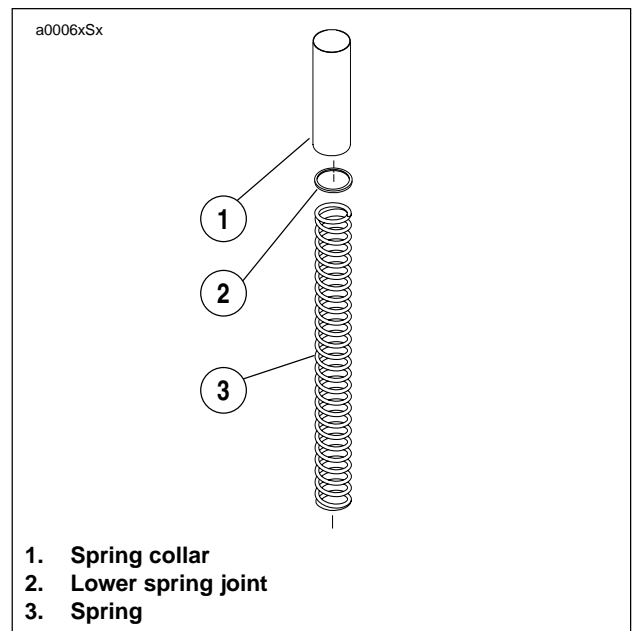
Figure 2-68. Slider Tube Cap

3. See [Figure 2-68](#). Remove slider tube cap.



Figure 2-69. Spring Seat

4. See [Figure 2-69](#). Push down on the spring seat (o-ring included) and remove the stopper ring and spring seat.



1. Spring collar
2. Lower spring joint
3. Spring

Figure 2-70. Removing Sub-Assembly

5. See [Figure 2-70](#). Remove the spring collar, lower spring joint and spring from slider tube.



Figure 2-71. Pumping Fork Oil

6. See [Figure 2-71](#). Remove the fork oil by pumping the fork leg and tube 8-10 times until the tube moves freely.



Figure 2-73. Removing Damper

8. See [Figure 2-73](#). Remove the damper assembly, lock piece and the rebound spring from the slider tube.



Figure 2-72. Removing Center Bolt

7. See [Figure 2-72](#). Remove the center bolt (metric) from the bottom of the fork tube.

IMPORTANT NOTE

Do not to scratch the slider tube or the slider assembly. Scratched tubes may leak fork oil and then must be replaced.



Figure 2-74. Removing Dust Seal

9. See [Figure 2-74](#). Remove the dust seal and the retaining ring from the slider assembly and the slider tube.

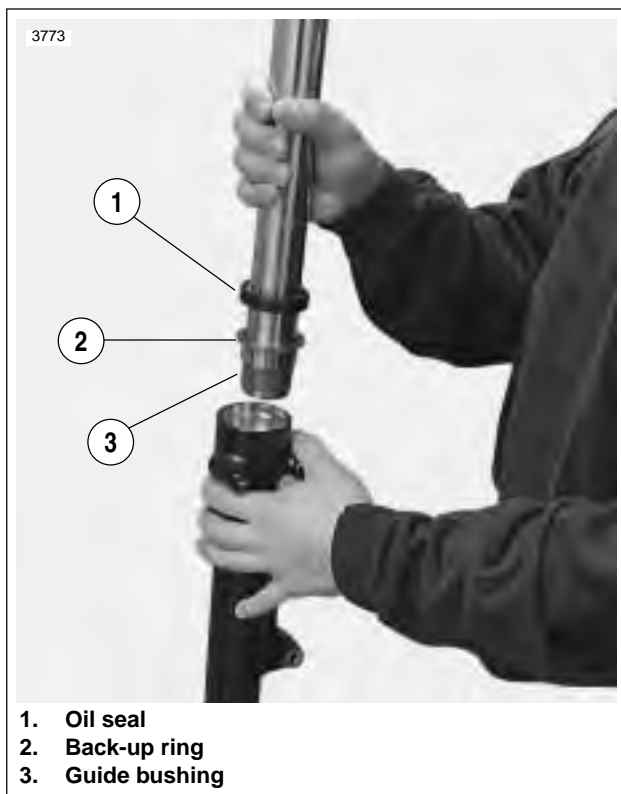


Figure 2-75. Removing Slider Tube

10. See [Figure 2-75](#). Pull the slider tube out of the slider assembly. Remove oil seal, back-up ring and guide bushing.



Figure 2-76. Removing Slide Bushing

11. See [Figure 2-76](#). Remove the slide bushing by prying the slide bushing at the split.

CLEANING AND INSPECTION

1. Thoroughly clean and inspect all parts. Replace any parts that are bent, broken or damaged.
2. See [Figure 2-77](#). Check the slider tube for score marks, scratches and excessive or abnormal wear. Replace if worn or damaged.
3. Check the slide bushing and the guide bushing for excessive wear or scratches. Replace if damaged or worn.
4. Replace the retaining ring if distorted.
5. Measure spring free length. Replace springs shorter than service wear limit of 12.8 in. (325 mm).
6. Measure rebound spring free length. Replace springs shorter than service wear limit of 0.69 in. (17.4 mm).
7. See [Figure 2-78](#). Measure slider tube runout. Replace slider tube if runout exceeds the service wear limit of 0.008 in. (0.2 mm).

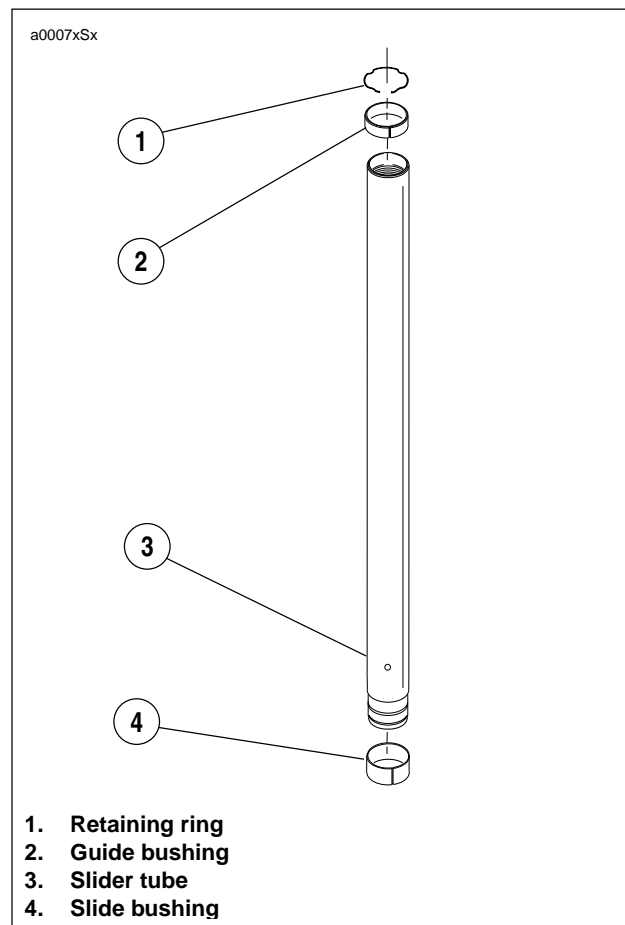


Figure 2-77. Slider Tube Components

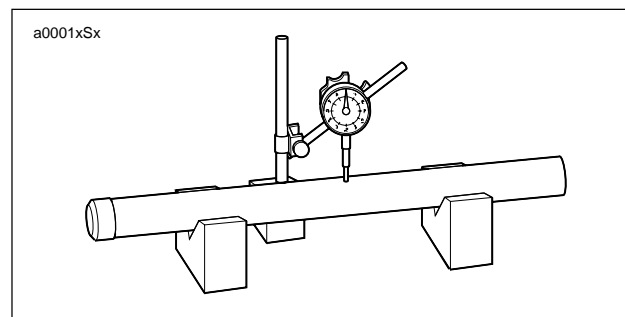


Figure 2-78. Slider Tube Runout

ASSEMBLY

1. Coat the slide bushing with fork oil or sealing grease.



Figure 2-79. Install Slide Bushing

2. See [Figure 2-79](#). Install slide bushing onto the slider tube.

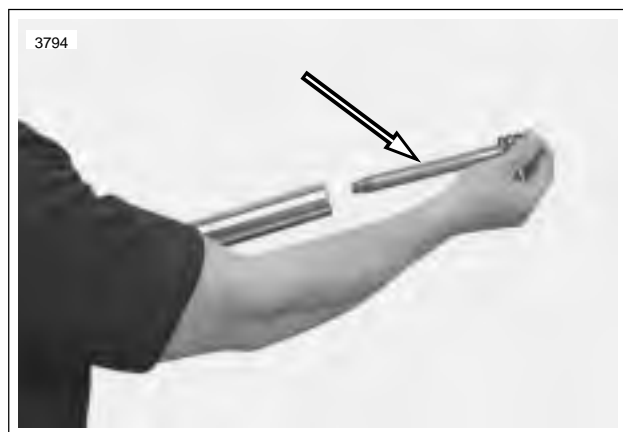


Figure 2-80. Damper Assembly

3. See [Figure 2-80](#). Install damper assembly and rebound spring into slider tube.

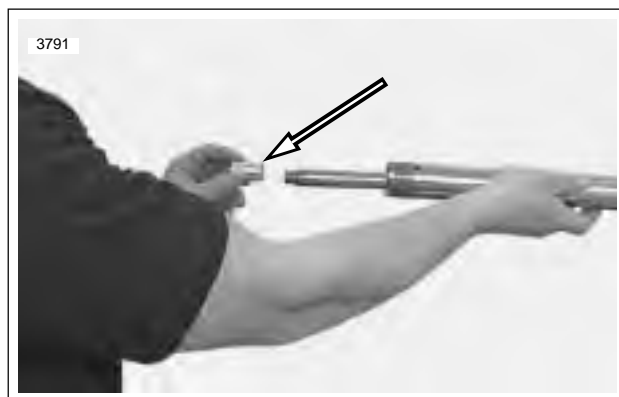


Figure 2-81. Lock Piece

4. See [Figure 2-81](#). Install lock piece into damper.



Figure 2-82. Clamping the Slider Assembly

5. See [Figure 2-82](#). Clamp the slider assembly in a vise with front fork holding tool (Part No. B-41177).



Figure 2-83. Installing Slider Tube

6. See [Figure 2-83](#). Install slider tube into slider assembly.

IMPORTANT NOTE

The slider assembly can move freely up and down on the slider tube. Always hold both the slider tube and slider assembly to prevent damage to bushings and seals.



Figure 2-84. Install Rebound Spring

7. See [Figure 2-84](#). Install spring onto damper assembly.



Figure 2-85. Install Center Bolt

- 8. See [Figure 2-85](#). Install center bolt and washer.
- 9. Coat the guide bushing with fork oil or sealing grease.



Figure 2-86. Install Guide Bushing

10. See [Figure 2-86](#). Install guide bushing onto the slider tube.

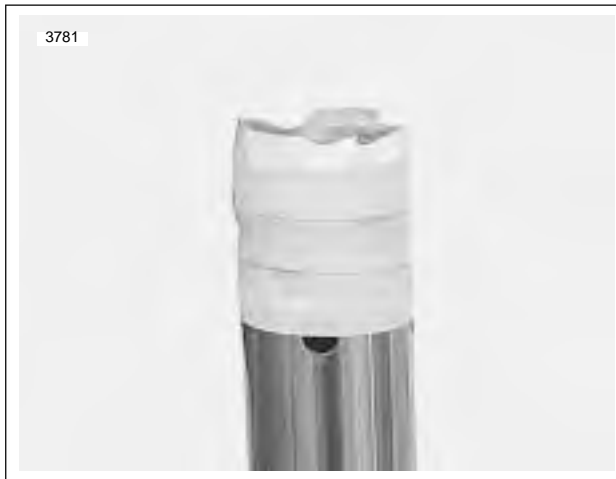


Figure 2-87. Slider Tube Protection

11. See [Figure 2-87](#). Wrap the end of the slide pipe and the slide bushing channel with tape to avoid damaging the oil seal lip when installing.
12. Coat dust seal, oil seal spacer, and backup ring with fork oil or sealing grease.



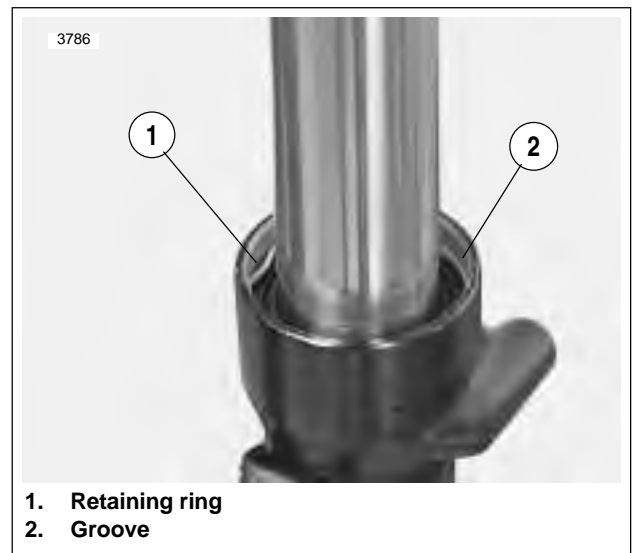
Figure 2-88. Oil Seal and Backup Ring

13. See [Figure 2-88](#). Install oil seal spacer and backup ring.



Figure 2-89. Fork Seal Driver

14. See [Figure 2-89](#). Using FORK SEAL DRIVER (Part No. B-43991), drive the guide bushing with the oil seal spacer and oil seal into position in the slider assembly.



1. Retaining ring
2. Groove

Figure 2-90. Install New Retaining Ring

15. See [Figure 2-90](#). Install retaining ring. Verify ring is installed securely in the groove inside slider assembly.



Figure 2-91. Install New Dust Seal

16. See [Figure 2-91](#). Install **new** dust seal onto slide pipe.



Figure 2-93. Compressing Spring Seat to Install Stopper Ring

22. See [Figure 2-93](#). Push down on spring seat past groove to install stopper ring. Stopper ring will lock into groove when installed correctly.

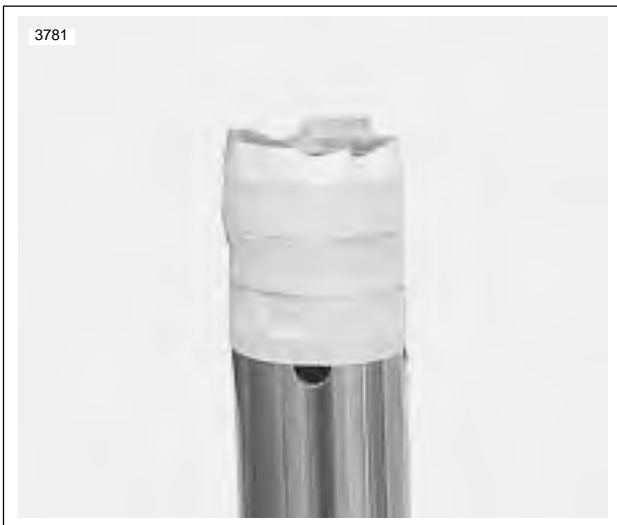


Figure 2-92. Remove Slider Tube Protection

17. See [Figure 2-92](#). Remove the tape from the slider tube end.

NOTE

The recommended fork oil is hydraulic fork oil type "E".

- 18. Pour 9.2 oz. (272 ml) fork oil into fork.
- 19. Install lower spring joint and spring collar.
- 20. Coat a **new** o-ring with fork oil or sealing grease.
- 21. Install **new** o-ring onto spring seat.



Figure 2-94. Slider Tube Cap

- 23. See [Figure 2-94](#). Install slider tube cap.
- 24. See [Figure 2-95](#). Install fork assemblies through upper and lower triple clamps.

INSTALLATION

1. See [Figure 2-95](#). Install fork assemblies through upper and lower triple clamps.



Figure 2-95. Installing Fork Assemblies

NOTE

When installing the front forks, use a screwdriver to pry apart the triple clamps.

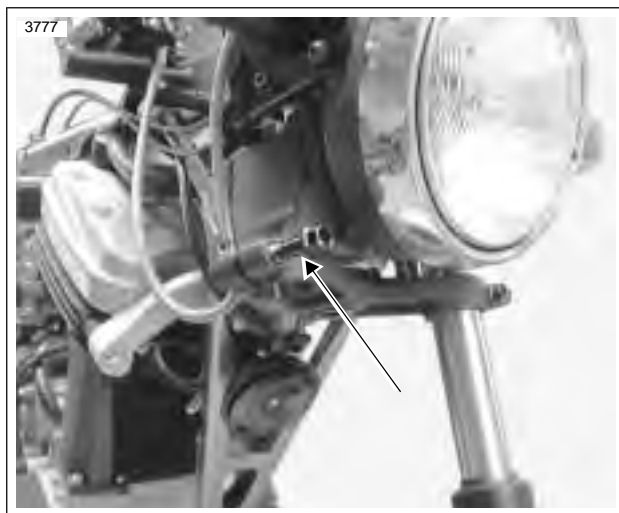


Figure 2-96. Location of Anti-Seize on Triple Clamp Pinch Screws

2. See [Figure 2-96](#). Apply Loctite Anti-Seize to the threads of triple clamp pinch screws.



Figure 2-97. Upper and Lower Triple Clamp Pinch Screws

3. See [Figure 2-97](#). Align and secure fork assemblies.
 - a. Position fork assemblies so that top of each slider tube is flush with the top surface of upper triple clamp. Be sure that top surface of fork is not below top surface of upper triple clamp.
 - b. Tighten upper triple clamp pinch screws (at sliders) to 13-16 ft-lbs (18-22 Nm).
 - c. Tighten lower triple clamp pinch screws to 22-29 ft-lbs (30-39 Nm).
 - d. See [Figure 2-98](#). Tighten headlamp brackets flush against bottom of top triple clamp.

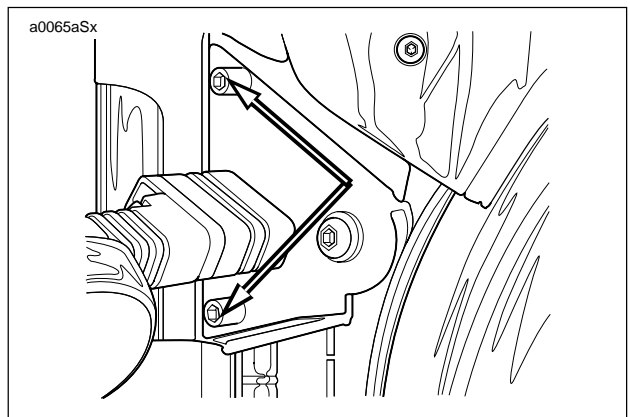


Figure 2-98. Tighten Headlamp Bracket Screws

4. Install front fender. See [2.23 FENDERS](#).
5. Install front wheel. See [2.5 FRONT WHEEL](#).
6. Install front brake caliper. See [2.11 FRONT BRAKE CALIPER](#).
7. Align headlamp. See [1.22 HEADLAMP](#).

REMOVAL/DISASSEMBLY

1. Remove seat. See 2.28 SEAT.

WARNING

To prevent accidental vehicle start-up, which could cause death or serious injury, disconnect negative (-) battery cable before proceeding. (00048a)

2. Disconnect battery.
3. Remove dash. See 2.27 INSTRUMENT PANEL.
4. Remove handlebars. See 2.30 HANDLEBARS.
5. Remove fork assembly. See 2.17 FRONT FORK.
6. Remove ignition switch assembly. See 7.6 IGNITION/ HEADLAMP KEY SWITCH.
7. See Figure 2-99. Remove screw (2) and capnut (1).
8. Support lower triple clamp (8) and remove upper triple clamp (3).
9. Remove upper dust shield (5) and upper bearing (6).
10. Lower triple clamp can be removed.
11. Remove lower bearing (6) and lower dust shield (5) from lower triple clamp.

CLEANING AND INSPECTION

1. See Figure 2-99. Clean the dust shields (5), bearing cups (7), fork stem and lower triple clamp (8) and frame with solvent.
2. Carefully inspect bearing races and assemblies for pitting, scoring, wear and other damage. Replace damaged bearings (6) as a set (5, 6 and 7).
3. Check the fork stem and lower triple clamp (8) for damage. Replace if necessary.

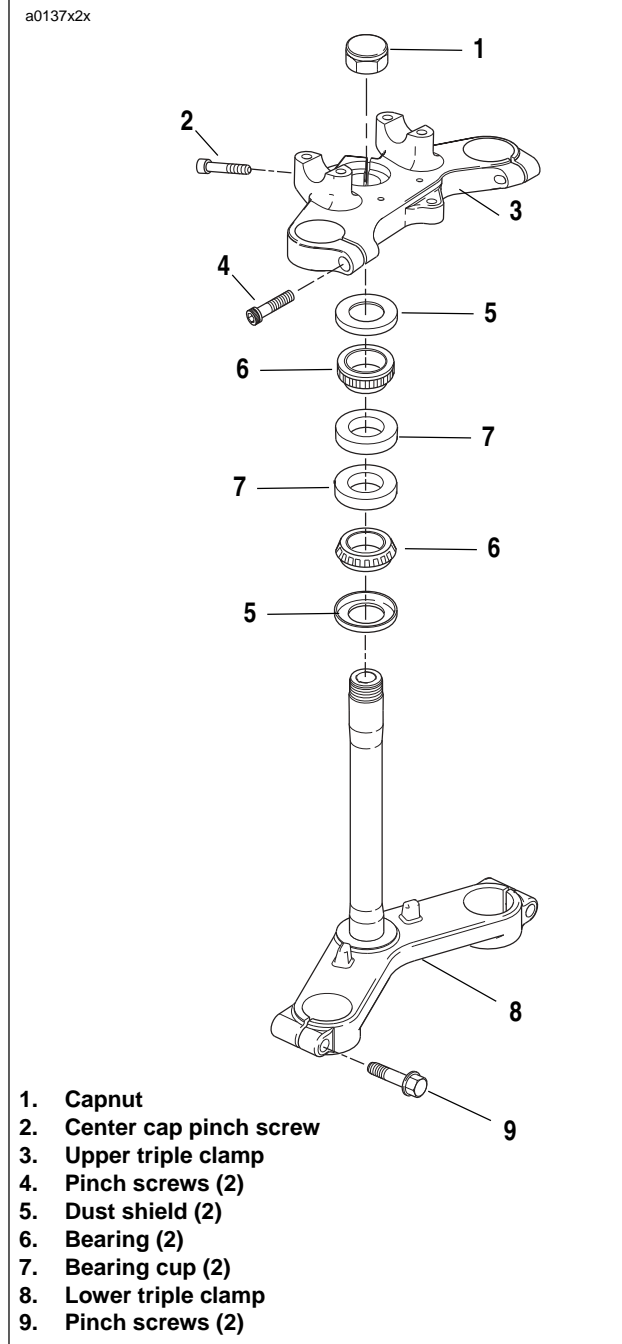


Figure 2-99. Fork Stem and Bracket Assembly

ASSEMBLY/INSTALLATION

1. If removed, install **new** bearing cups into frame steering head using STEERING HEAD BEARING RACE INSTALLER (Part No. HD-39302).
2. See [Figure 2-99](#). Liberally coat the bearings (6) with grease using WHEEL BEARING PACKER TOOL (Part No. HD-33067). Work the grease into the rollers.
3. Install lower bearing:
 - a. Place lower bearing dust shield (5) over fork stem.
 - b. Find a section of pipe having an inside diameter slightly larger than the outside diameter of the fork stem.
 - c. Press bearing (6) with small end up onto fork stem and lower triple clamp (8). Use the pipe as a press-on tool.
4. Insert lower triple clamp (8) through the steering head. Install the upper bearing (6) with small end down and dust shield (5) onto fork stem.
5. Apply Loctite 243 (Blue) to fork stem. Loosely install upper triple clamp (3) using cap nut (1).
6. Install fork assemblies. See [2.17 FRONT FORK](#).
7. Tighten cap nut (1) until the bearings have no free play. Make sure the fork stem turns freely.
8. Check steering head bearing adjustment. See [1.15 STEERING HEAD BEARINGS](#).
9. Install handlebars. See [2.30 HANDLEBARS](#).
10. Install dash. See [2.27 INSTRUMENT PANEL](#).
11. Connect battery negative cable.
12. Install seat. See [2.28 SEAT](#).

 **WARNING**

After installing seat, pull upward on front of seat to be sure it is in locked position. While riding, a loose seat can shift causing loss of control, which could result in death or serious injury. (00070a)

REMOVAL

1. Remove seat. See 2.28 SEAT.
2. Remove battery. See 7.16 BATTERY.

WARNING

Disconnect negative (-) battery cable first. If positive (+) cable should contact ground with negative (-) cable connected, the resulting sparks can cause a battery explosion, which could result in death or serious injury. (00049a)

3. Remove right side footpeg support bracket. See 2.21 FOOTPEGS AND FOOTPEG SUPPORT BRACKETS.
4. Remove three bolts holding front sprocket cover. See 2.22 SPROCKET COVER.
5. Remove inner fender. See 2.23 FENDERS.
6. Remove lower belt guard. See 2.24 LOWER BELT GUARD.
7. Remove rear axle nut, axle, spacers and brake with carrier. See 2.6 REAR WHEEL.
8. Remove drive belt. See 1.11 DRIVE BELT AND REAR SPROCKET.
9. Remove rear wheel. See 2.6 REAR WHEEL.
10. Remove lower rear shock fastener. See 2.15 REAR SHOCK ABSORBER.
11. See Figure 2-100. Loosen swing arm pinch screw (1).
12. Remove swingarm pivot bolt (6) and swingarm.
13. Remove well nuts from swingarm.
14. Use slide hammer (SNAP-ON Part No. CJ1275 or equivalent) and bearing remover to remove bearings (4).
15. Remove swingarm spacer (5).

INSTALLATION

1. See Figure 2-100. Install **new** bearings (4) and spacer (5).
2. Position swing arm in mounting block. Apply anti-seize to swingarm bolt (6) and install. Tighten to 24-26 ft-lbs (33-35 Nm).
3. Apply Loctite 243 (blue) to pinch screw (1) and install. Tighten to 17-19 ft-lbs (23-26 Nm).
4. Install well nuts.
5. Install rear shock and fastener. Tighten to 35-40 ft-lbs (47-54 Nm).
6. Install rear wheel, axle, brakes, and spacers. Tighten rear axle nut to 49-51 ft-lbs (67-69 Nm).
7. Install drive belt.
8. Install rear fender, lower belt guard, and sprocket cover.
9. Loosely install right side footpegs mount.
10. Install reservoir, master cylinder, and brake pedal. Tighten brake pedal bolt to 72-96 **in-lbs** (8-11 Nm).
11. Tighten footpeg mounting bracket.

WARNING

Connect positive (+) battery cable first. If positive (+) cable should contact ground with negative (-) cable connected, the resulting sparks can cause a battery explosion, which could result in death or serious injury. (00068a)

12. Install battery. See 7.16 BATTERY.

WARNING

After repairing the brake system, test brakes at low speed. If brakes are not operating properly, testing at high speeds can cause loss of control, which could result in death or serious injury. (00289a)

WARNING

After installing seat, pull upward on front of seat to be sure it is in locked position. While riding, a loose seat can shift causing loss of control, which could result in death or serious injury. (00070a)

13. Install seat. See 2.28 SEAT.

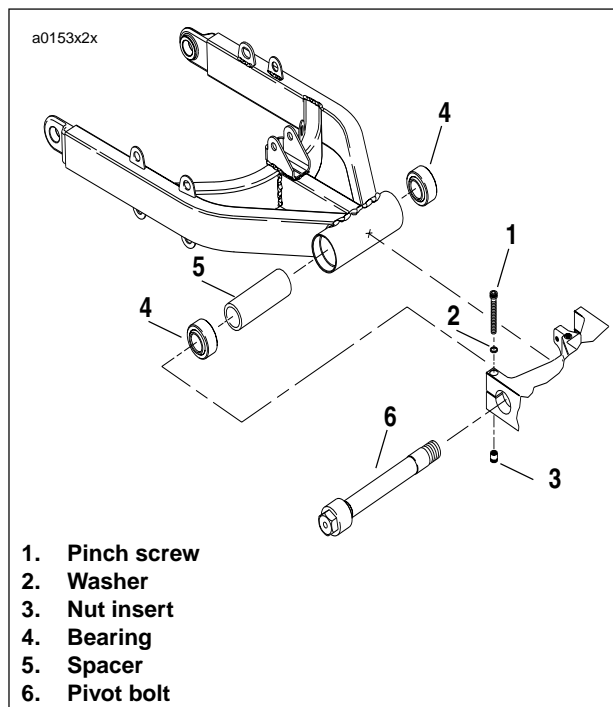


Figure 2-100. Swingarm

MUFFLER REMOVAL

IMPORTANT NOTE

To prevent damage to muffler, secure muffler before removing rear muffler strap.

1. See [Figure 2-101](#). Remove fasteners, washers, spacers and brackets on rear muffler strap.
2. Remove exhaust header fasteners (13).
3. Remove front muffler mounting fastener, nut, and washer (4, 7, 12).
4. Remove exhaust header.
5. Remove retaining ring (2).
6. Remove exhaust header clamp (3).
7. Remove and discard exhaust port gasket (1).

MUFFLER INSTALLATION

1. See [Figure 2-101](#). Install **new** bushings and spacer into front muffler support hole (8, 17, 11).
2. Install header clamp onto exhaust (3).
3. Install retaining ring oriented 90° from exhaust studs (2).

NOTE

Retaining ring may crack if not oriented as stated in step 3.

4. Install **new** exhaust port gasket (1).
5. Position muffler on motor. Hand tighten nuts (13).
6. Slide muffler over bushings on front mount.
7. Hand thread bolt washer and nut to front muffler support.
8. Install rear muffler strap (15).

NOTE

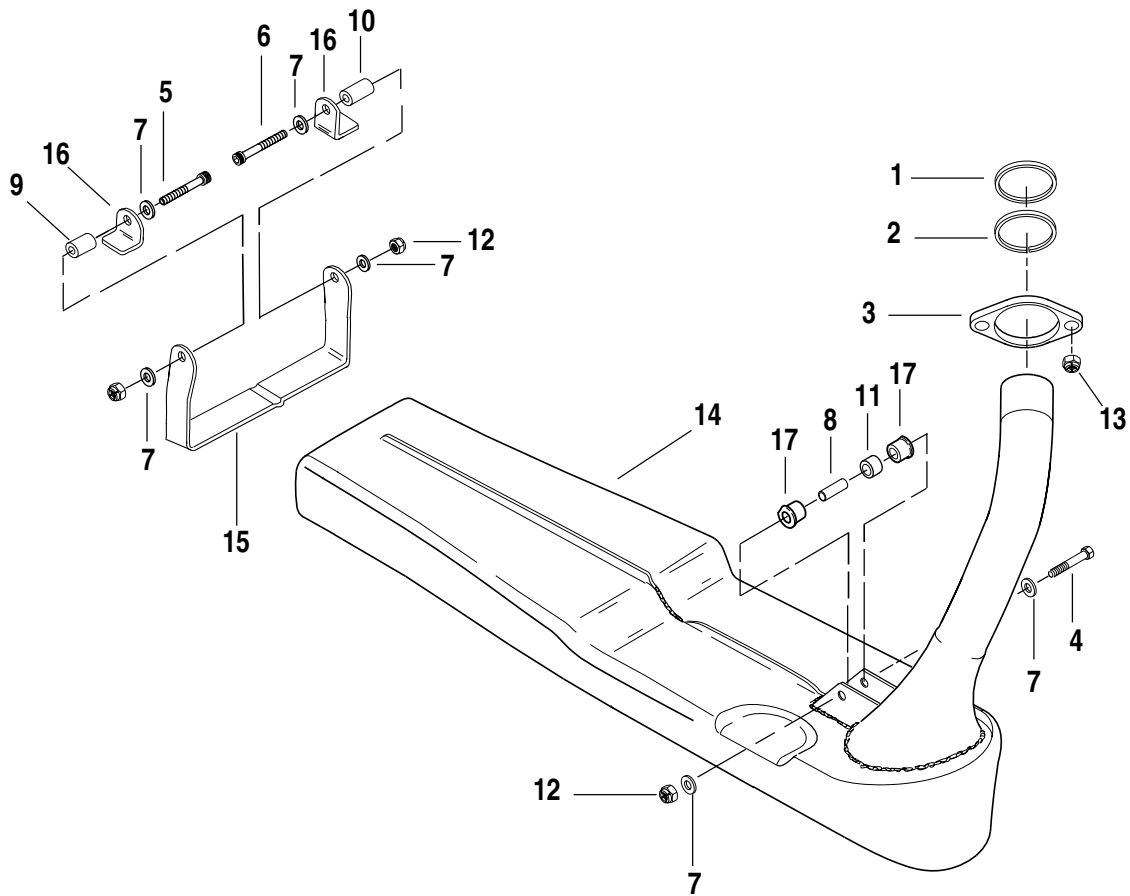
A rubber mallet may be used to tap the muffler strap into muffler notches.

9. Install right side muffler spacers (9), brackets (16) and fasteners (5).
10. Install left side muffler spacers, brackets and fasteners.
11. Tighten nuts (12) on rear muffler strap bolts (5,6) to 19 ft-lbs (25.8 Nm).
12. Tighten lower, then upper header nuts to 72-96 **in-lbs** (8-11 Nm).
13. Tighten rear strap screws (5, 6) to 17-19 ft-lbs (24-25 Nm).
14. Tighten front muffler bolts (4) to 17-19 ft-lbs 24-25 Nm).

IMPORTANT NOTE

Use care when performing service procedures and avoid scratching the frame and/or painted parts. Failure to do so may result in corrosion of parts.

a0160x2x



- | | |
|----------------------------|-------------------------|
| 1. Gasket, exhaust port | 10. Spacer, left |
| 2. Retaining ring, exhaust | 11. Spacer |
| 3. Clamp, exhaust ring | 12. Nut (2) |
| 4. Bolt | 13. Nut (2) |
| 5. Screw | 14. Muffler, complete |
| 6. Screw | 15. Muffler strap, rear |
| 7. Washer (6) | 16. Bracket (2) |
| 8. Spacer | 17. Grommet (2) |
| 9. Spacer, right | |

Figure 2-101. Exhaust System Assembly

REMOVAL

Footpeg

1. See [Figure 2-102](#). Remove cotter pin (3).
2. Remove clevis pin (4).
3. Remove spacer (7, rear peg only).
4. Remove footpeg.

Footpeg Support Bracket

1. Remove seat. See [2.28 SEAT](#).
2. See [Figure 2-103](#). On left side remove oil tank drain hose, breather drain hose, clamp and fastener.
3. On right side remove rear master cylinder, spacers, reservoir, and brake pedal.
4. See [Figure 2-102](#). Remove mounting bolts located behind footpeg support bracket.
5. Remove footpeg support bracket.

INSTALLATION

Footpeg Support Bracket

1. Align footpeg support mounting bracket and spacer with mounting holes on frame.
2. Install mounting bolts and washers. Tighten fasteners to 25-30 ft-lbs. (34-41 Nm).
3. See [Figure 2-103](#). On left side install clamp with oil tank drain hose and breather hose.
4. On right side install rear master cylinder, spacers, reservoir, and brake pedal. See [2.13 REAR BRAKE MASTER CYLINDER](#).

WARNING

After installing seat, pull upward on front of seat to be sure it is in locked position. While riding, a loose seat can shift causing loss of control, which could result in death or serious injury. (00070a)

5. Install seat. See [2.28 SEAT](#).

Footpeg

1. See [Figure 2-102](#). Align footpeg mounting holes with footpeg support bracket mounting holes.
2. Insert dowel pin (and on rear peg, spacer) through mounting holes.
3. Install **new** cotter pin.

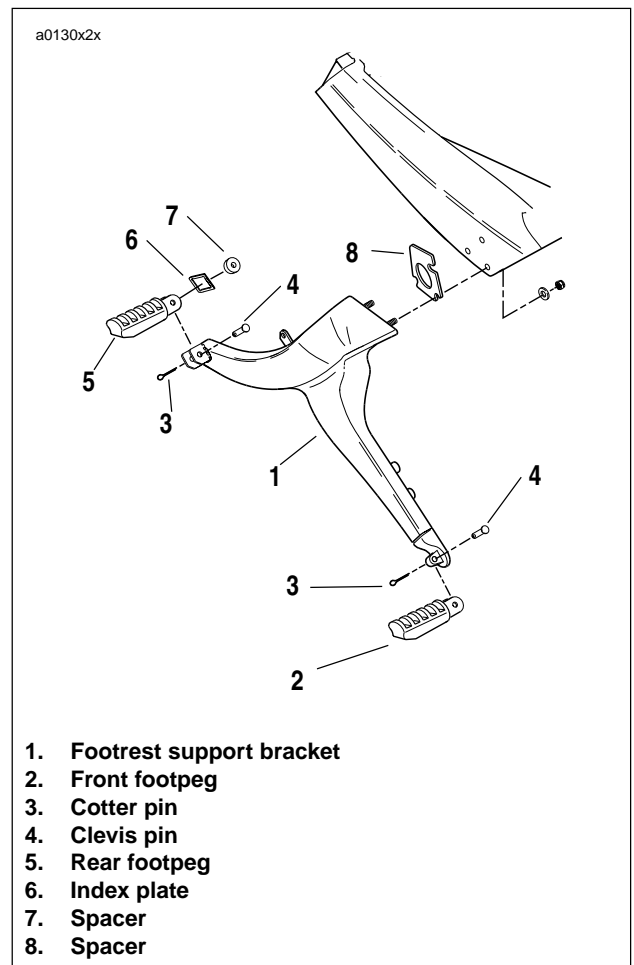


Figure 2-102. Footpeg Support Bracket (Left Side)

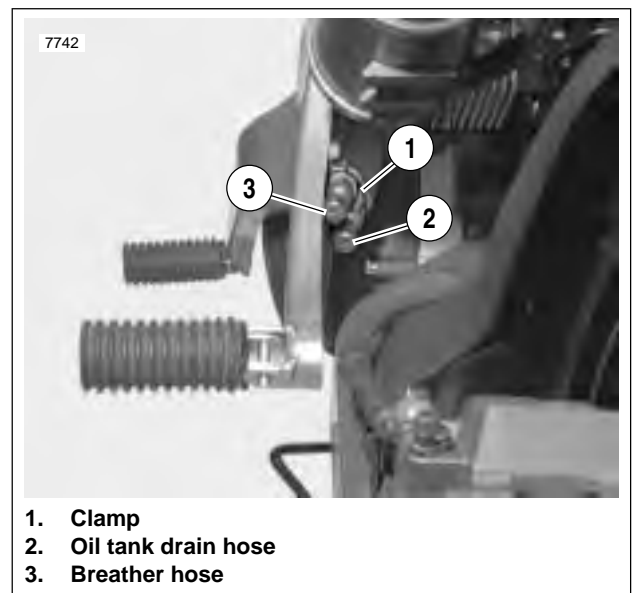


Figure 2-103. Left Side Footpeg Support Bracket

REMOVAL

1. See [Figure 2-104](#). Remove master cylinder bolts and spacers.
2. Remove rear pedal bolt and move pedal assembly down away from support bracket.
3. See [Figure 2-105](#). Remove the three screws and washers on sprocket cover.
4. Slide cover free.

INSTALLATION

1. Apply Loctite 243 (blue) to threads of three screws.
2. Position sprocket cover and install three screws and washers. Tighten fasteners to 30-36 **in-lbs** (3-4 Nm).
3. Move pedal assembly in position and install pedal bolt. Tighten pedal bolt to 72-96 **in-lbs** (8-11 Nm).
4. Install master cylinder bolts and spacers. See [2.13 REAR BRAKE MASTER CYLINDER](#).

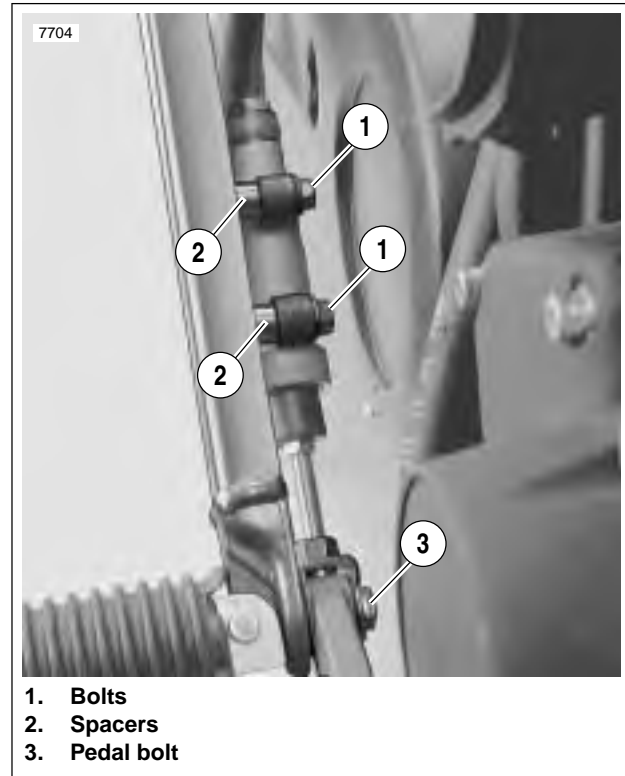


Figure 2-104. Master Cylinder Mounting

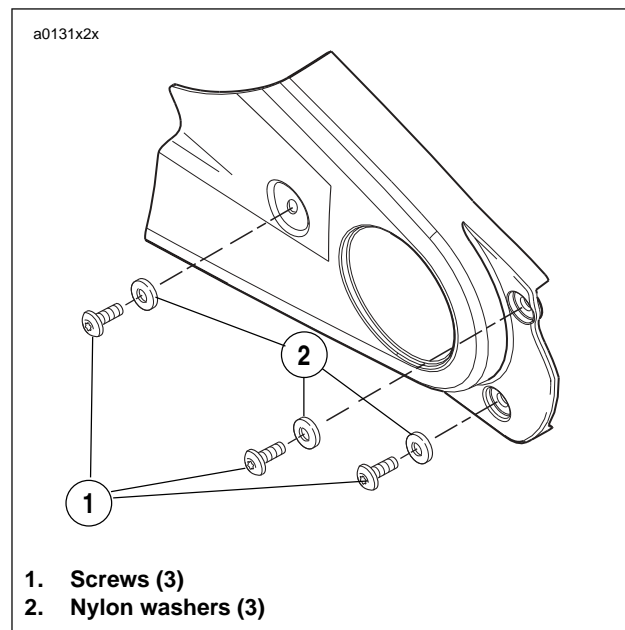


Figure 2-105. Sprocket Cover Fasteners

FRONT FENDER REMOVAL

1. Raise front wheel off ground.
2. Remove front wheel. See [2.5 FRONT WHEEL](#).

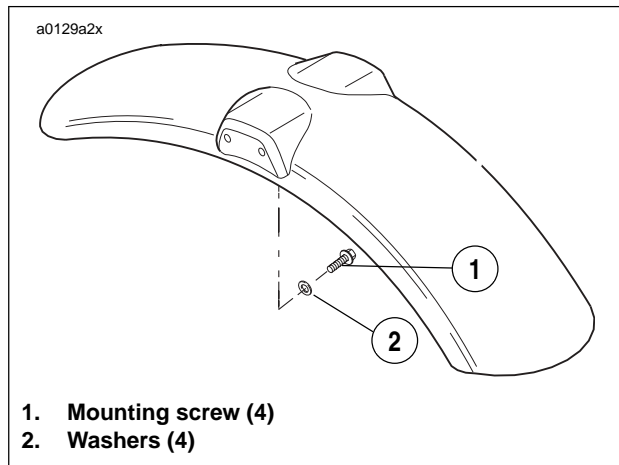


Figure 2-106. Front Fender Assembly Mounting Screws

3. See [Figure 2-106](#). Remove four lower fender mounting screws.

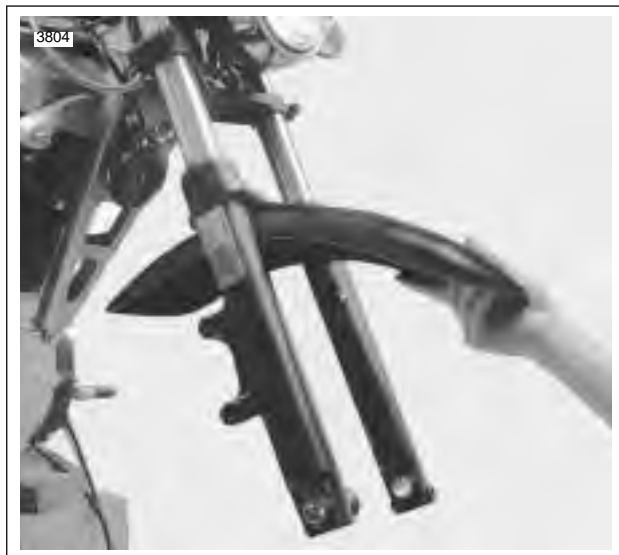


Figure 2-107. Removing Front Fender

4. See [Figure 2-107](#). Remove front fender.

FRONT FENDER INSTALLATION

1. Raise front wheel off floor.
2. Align front fender mounting holes with front fork bracket.

NOTE

The longer end of the fender faces away from the front end.

3. Apply Loctite 243 (blue) to first few threads of four fender mounting screws.
4. See [Figure 2-106](#). Install front fender with four fender mounting screws.
5. Tighten fender mounting screws to 27-30 in-lbs (3.1-3.4 Nm).

REAR FENDER REMOVAL

1. Remove seat. See [2.28 SEAT](#).
2. Remove right side footpeg support. See [2.21 FOOTPEGS AND FOOTPEG SUPPORT BRACKETS](#).

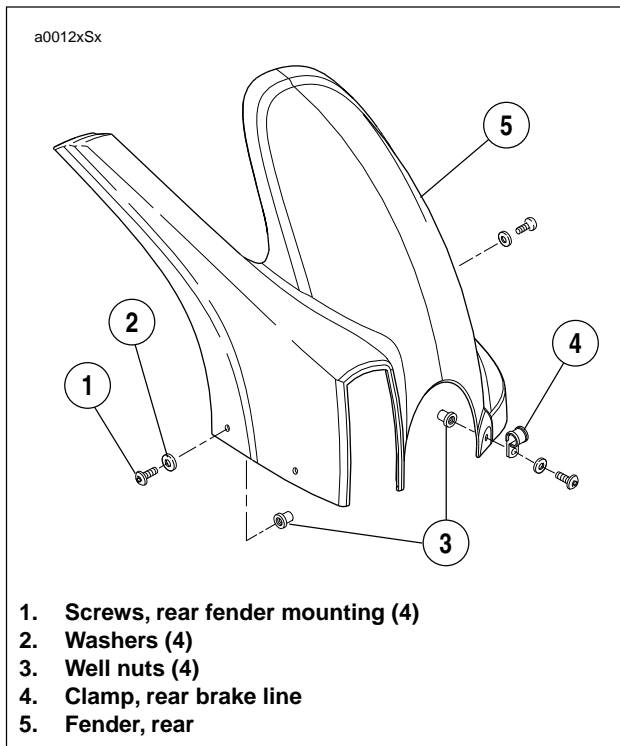


Figure 2-108. Rear Fender Assembly

3. See [Figure 2-108](#). Remove rear fender mounting screws and washers from rear fender.
4. Remove rear fender.

REAR FENDER INSTALLATION

1. Position rear fender.
2. Install rear fender mounting screws, washers and well-nuts on rear fender.
3. Tighten rear fender mounting screws to 30-36 **in-lbs** (3-4 Nm).
4. Install right side footrest support bracket. See [2.21 FOOTPEGS AND FOOTPEG SUPPORT BRACKETS](#).

WARNING

After installing seat, pull upward on front of seat to be sure it is in locked position. While riding, a loose seat can shift causing loss of control, which could result in death or serious injury. (00070a)

5. Install seat. See [2.28 SEAT](#).

REMOVAL

1. See [Figure 2-109](#). Remove two screws and nylon washers securing lower belt guard to swingarm.
2. Remove belt guard.

INSTALLATION

1. Position belt guard over tabs on swingarm.
2. Secure belt guard with two screws and nylon washers.
3. Tighten screws to 30-36 **in-lbs** (3-4 Nm).

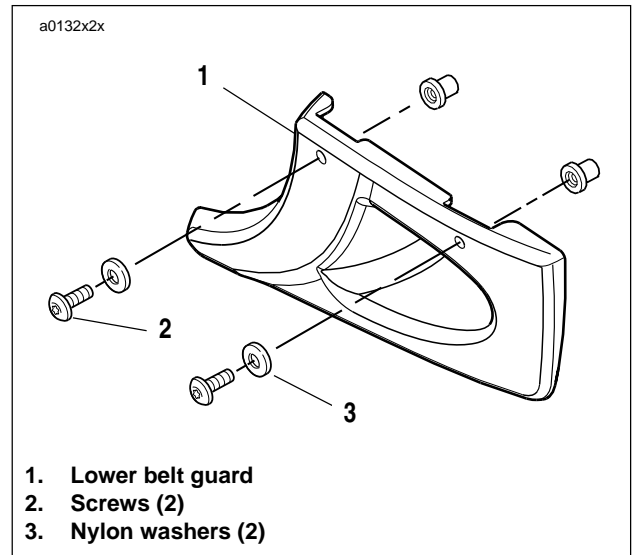


Figure 2-109. Lower Belt Guard

REMOVAL - TAIL SECTION

1. Remove seat. See 2.28 SEAT.
2. See Figure 2-110. Remove fasteners and clamp (3, 19 and 20).
3. Remove tree fasteners (2).
4. Remove fairing, tail section (1).
5. Disconnect battery negative cable.
6. Unplug taillight.
7. Cut cable strap holding taillight and turn signal wires.
8. Unplug turn signals.
9. Remove nut (8) and lock washer (7).
10. Remove turn signals (6).
11. Remove nuts and flat washers from back of taillight.
12. Remove taillight.
13. Remove bolts (4) and nuts (9).
14. Remove license plate bracket (5).

WARNING

To prevent accidental vehicle start-up, which could cause death or serious injury, disconnect negative (-) battery cable before proceeding. (00048a)

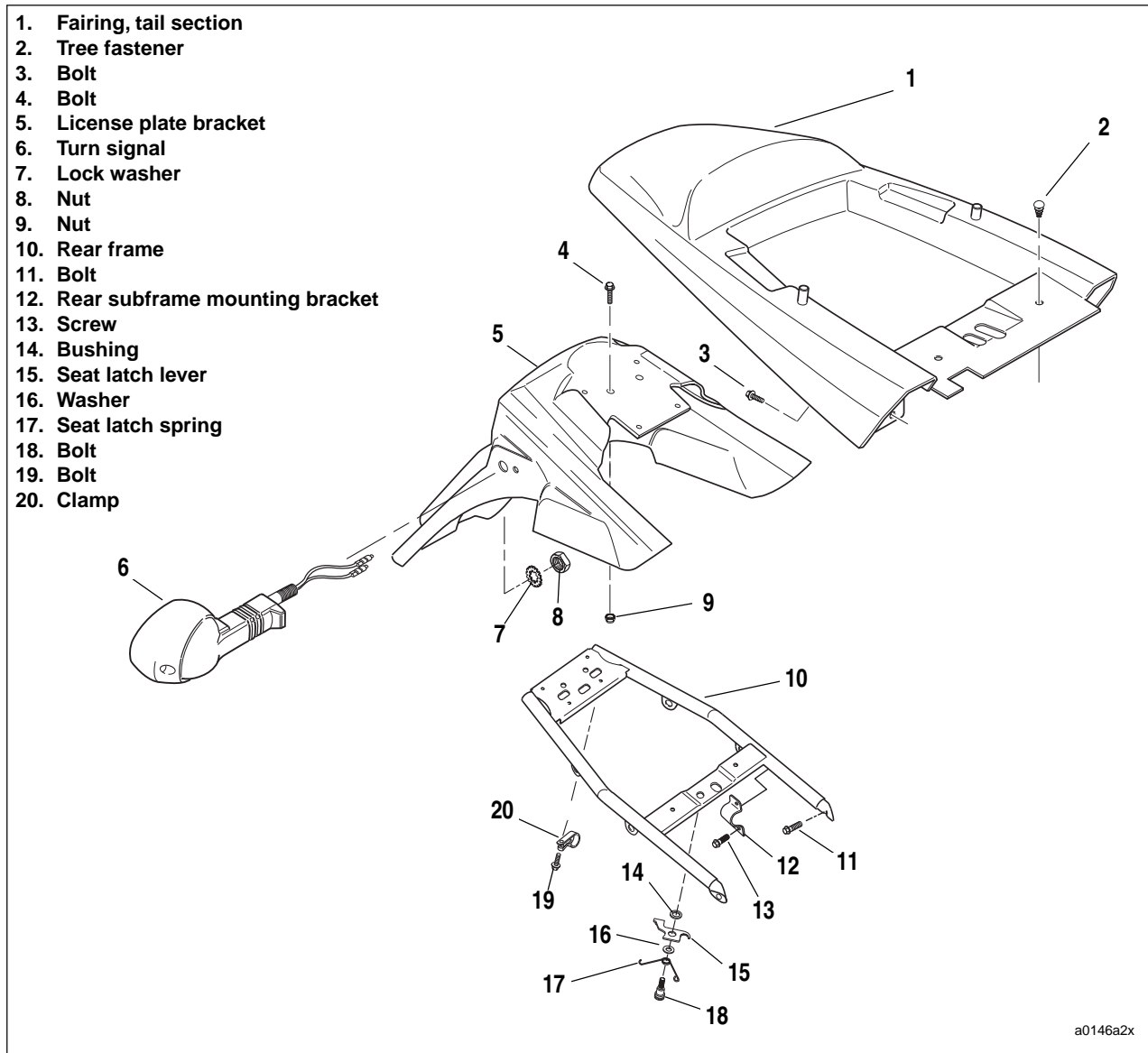


Figure 2-110. Tail Section

REMOVAL - REAL FRAME ASSEMBLY

1. Remove tail section.
2. Disconnect rear wire harness connector [7] (6-place amp), located under seat near fuse block. Detach connector from "T" stud.
3. See [Figure 2-110](#). Remove fasteners (13) and bracket (12).
4. Remove fasteners (11).
5. Slide rear frame assembly (10) out.

INSTALLATION - REAR FRAME ASSEMBLY

1. See [Figure 2-110](#). Slide rear frame assembly (10) into frame.
2. Install fasteners (11).
3. Install brackets (12) and fasteners (13).
4. Connect rear wire harness and mount on "T" stud.

INSTALLATION - TAIL SECTION

1. See [Figure 2-110](#). Install license plate bracket (5) using fasteners (4) and nuts (9) in rear holes.
2. Install taillight using flat washers and nuts.
3. Install turn signals (6) using lock washers (7) and nuts (8).
4. Connect turn signal wires and taillight wires. Cable tie together.
5. Install tail section (1) using fasteners (3, 19, 20).
6. Connect battery negative cable.

WARNING

After installing seat, pull upward on front of seat to be sure it is in locked position. While riding, a loose seat can shift causing loss of control, which could result in death or serious injury. (00070a)

7. Install seat. See [2.28 SEAT](#).

REMOVAL

1. See [Figure 2-111](#). Remove two screws and nylon washers on each side.
2. Remove windscreen.
3. See [Figure 2-112](#). Remove windscreen trim.
4. Remove windscreen mounting brackets, if required. See [7.17 HEADLAMP](#).

INSTALLATION

1. If removed, install both windscreen brackets. See [7.17 HEADLAMP](#).
2. Verify trim is installed on windscreen.
3. See [Figure 2-111](#). Install two screws and nylon washers on each side. Tighten screws to 9-11 **in-lbs** (1-1.2 Nm).



Figure 2-111. Remove Screws

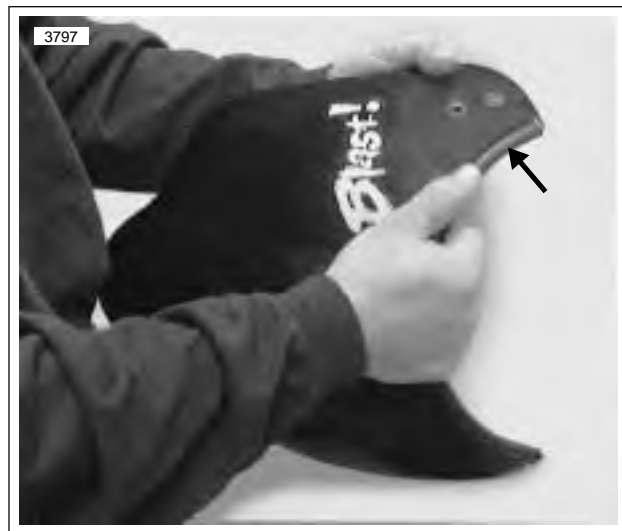


Figure 2-112. Windscreen Trim

REMOVAL

1. See [Figure 2-113](#). Remove two mounting screws (1) and instrument panel.
2. Remove two screws from back of instrument panel.
3. Remove rubber boot (2) and odometer reset switch (3).
4. Depress tab and remove speedometer connector [39].

NOTE

To remove speedometer, see [7.25 ELECTRONIC SPEEDOMETER](#).

INSTALLATION

1. See [Figure 2-113](#). Install odometer reset switch to instrument panel and install rubber boot.
2. Install connector [39] on back of speedometer.
3. Apply Loctite 243 (blue) to threads of mounting screws. Install dash with two mounting screws. Tighten screws to 30-36 **in-lbs** (3-4 Nm).

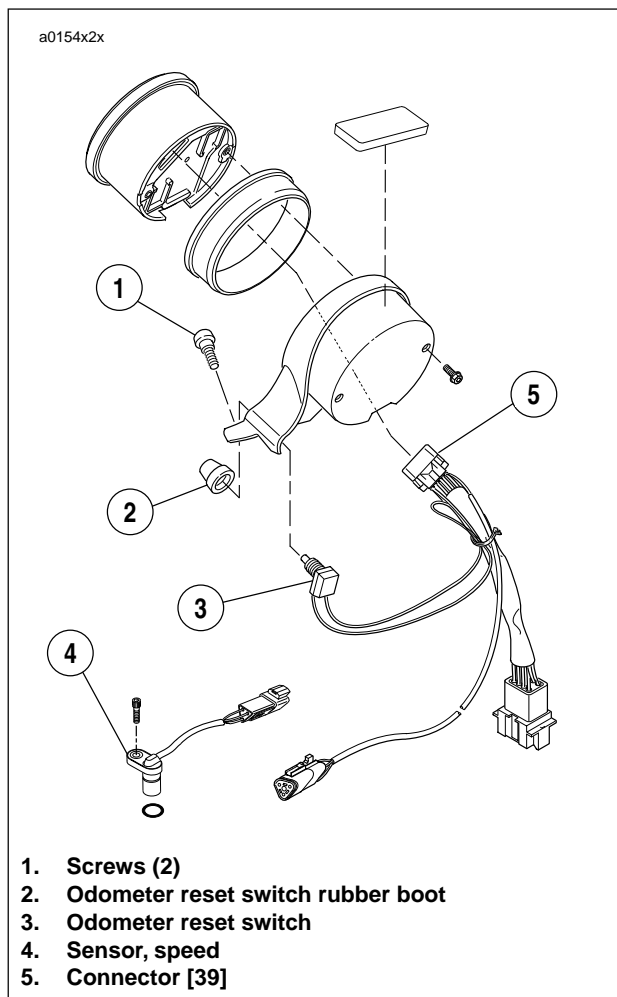


Figure 2-113. Instrument Panel

REMOVAL

IMPORTANT NOTE

Use both hands to release tension on the seat latch to avoid pinching fingers.

You will need to use both hands during this operation to release tension on the seat latch (located beneath the seat).

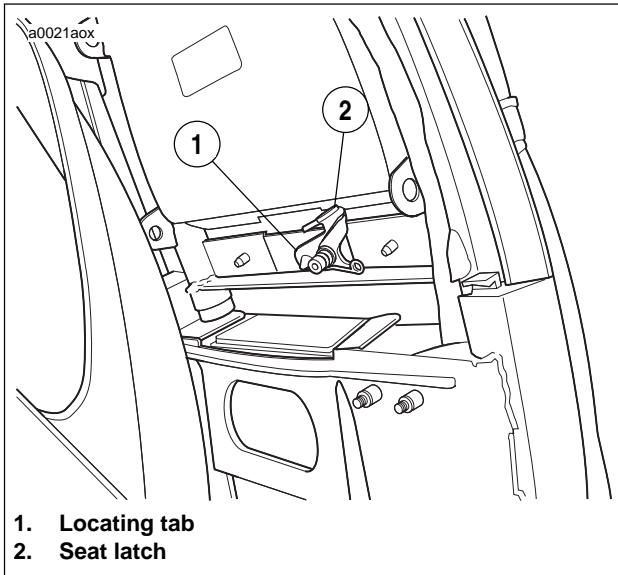


Figure 2-114. Seat Latch

1. See [Figure 2-114](#). Push or pull the seat latch toward the front of the motorcycle with your thumb.
2. Grasp the rear section of the seat with one hand.
3. Lift seat away from motorcycle to loosen from frame.

INSTALLATION

1. See [Figure 2-115](#). Locate tab on bottom of seat.

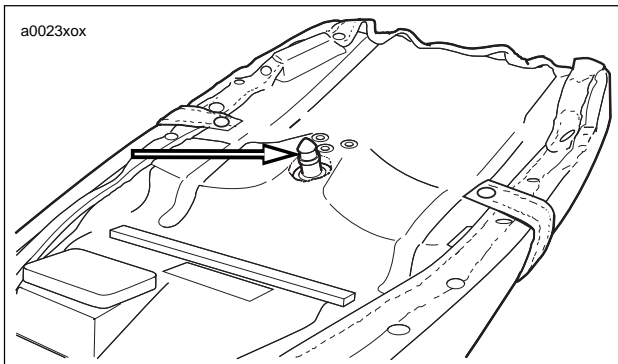


Figure 2-115. Underside View of Seat with Locating Tab

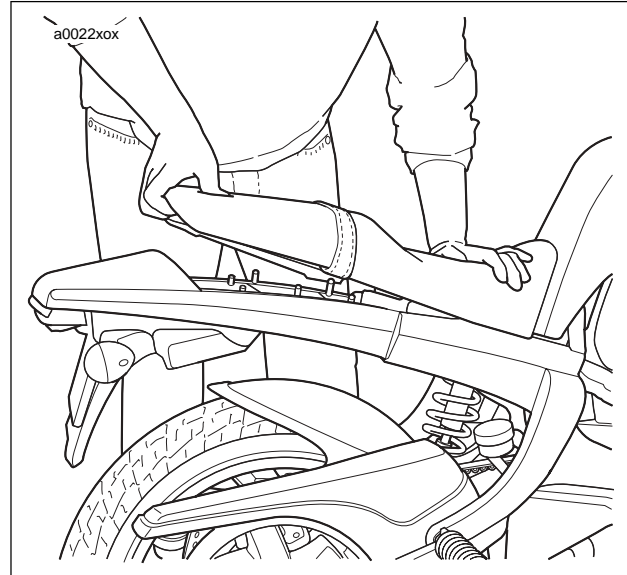


Figure 2-116. Seat Installation

2. See [Figure 2-116](#). Ensure seat is upright. Grasp the rear section of the seat with one hand and grasp the front section of the seat with the other hand.
3. See [Figure 2-117](#). Push seat forward while flexing the rear section of the seat upward until the tongue locks into the bracket located on the frame.
4. Push down firmly on the seat

NOTE

You will hear a click when the locating tab and seat latch lock together.

WARNING

After installing seat, pull upward on front of seat to be sure it is in locked position. While riding, a loose seat can shift causing loss of control, which could result in death or serious injury. (00070a)

5. Verify seat is locked in position.

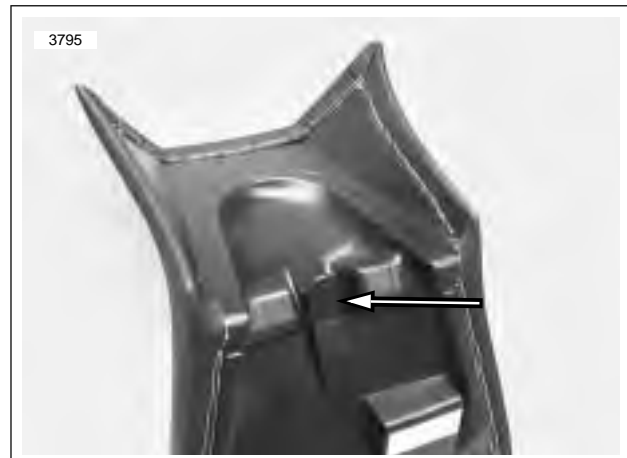


Figure 2-117. Locking Seat Tongue

GENERAL

⚠ WARNING

This motorcycle does NOT have a locking sidestand. Park the motorcycle on a level, firm surface. An unbalanced motorcycle can fall, which could result in death or serious injury. (00122a)

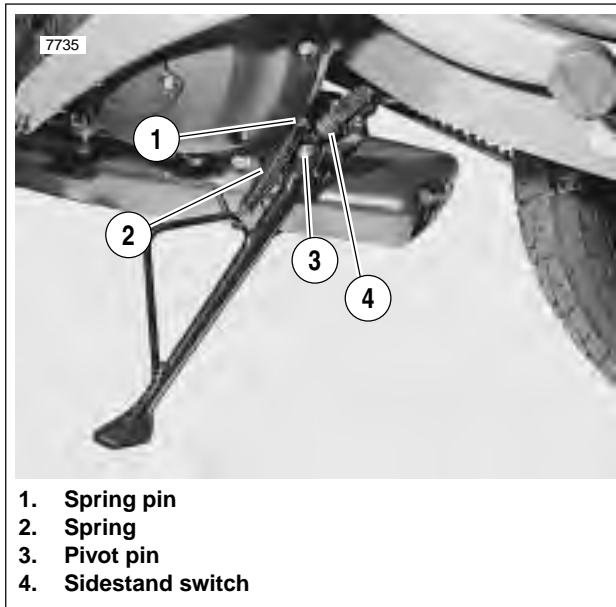


Figure 2-118. Sidestand

See [Figure 2-118](#). The sidestand is located on the left side of the motorcycle. The sidestand swings outward to support the motorcycle for parking.

Test the sidestand in the following manner. Without vehicle weight resting on it, sidestand should move freely into extended (down) and retracted (up) positions.

The sidestand activates the sidestand switch (4) which is part of the starter interlock system.

INSPECTION

1. Test the sidestand with the vehicle upright and level. The sidestand should move freely into extended down and up position.
2. Check sidestand switch operation after first 1000 miles (1600 km) and every 2500 miles (4000 km).

DISASSEMBLY/REMOVAL

1. Raise rear wheel off floor using REAR WHEEL SUPPORT STAND (Part No. B-41174).
2. Disconnect electrical connection.
3. Cut cable strap from rear brake line.
4. Remove spring (2) from sidestand.
5. Remove cotter pin and pivot pin (1).
6. Remove sidestand from frame.

ASSEMBLY/INSTALLATION

1. See [Figure 2-118](#). Apply LITHIUM GREASE to pivot pin.

NOTE

Do not crush sidestand switch during installation.

2. Install sidestand using pivot pin and cotter pin.
3. Connect spring to sidestand and spring pin.
4. Remove REAR WHEEL SUPPORT STAND (Part No. B-41174).
5. Inspect sidestand and sidestand switch for proper operation.

REMOVAL

1. See [Figure 2-119](#). Remove left side switch housing (13).
2. Loosen clutch adjuster and remove clutch cable (8).
3. Unplug clutch lever switch (9).
4. Remove left handlebar grip (12).
5. Loosen clutch lever screw (4) and slide clutch lever and bracket assembly off of handlebar (3).
6. Disconnect front brake lever switch (16).
7. Slide rubber boot off the throttle cable adjusters. Loosen cable adjuster lock on each adjuster.
8. Turn adjusters in direction which will shorten cable housings to minimum length providing freeplay in both cables.
9. Remove two screws on right switch assembly. Separate housings (14) from handlebar.
10. Remove cables from notches in housings.
11. Unhook ferrules from cable wheel.
12. Remove throttle grip (15).
13. Remove front master cylinder clamp bolts.
14. Remove master cylinder.
15. Remove upper handlebar clamp screws (1) and upper handlebar clamps (2).
16. Remove handlebar (3).

INSTALLATION

1. Position handlebar (3) on upper triple clamp.
2. Install upper handlebar clamps (2) and screws (1).
3. Tighten screws in steps maintaining even gap between upper triple clamp and upper handlebar clamps. Final tighten to 120-144 **in-lbs** (14-16 Nm).
4. Install master cylinder. Tighten master cylinder clamp bolts to 80-120 **in-lbs**. (9-14 Nm).
5. Install throttle grip.
6. Hook ferrules to cable wheel. Position cables in notches of switch housing (14).
7. Position housings on right handlebar. Front housing has locating pin that must align with hole in handlebar. Install fasteners, longer screw on bottom. Tighten fasteners to 25-33 **in-lbs** (3-4 Nm).
8. Plug in front brake lever switch (16).
9. Adjust throttle cables. See [1.18 THROTTLE CABLES](#).
10. Install clutch lever and bracket assembly. Tighten clutch lever screw (4) to 40-48 **in-lbs** (4.6-5.4 Nm).
11. Install hand grip (12).
12. Install clutch cable (8).
13. Adjust clutch. See [1.9 CLUTCH](#).
14. Plug terminal into clutch lever switch (9).
15. Install left side switch housing (13). Front housing has locating pin that must align with hole in handlebar. Tighten fasteners to 25-33 **in-lbs** (3-4 Nm).

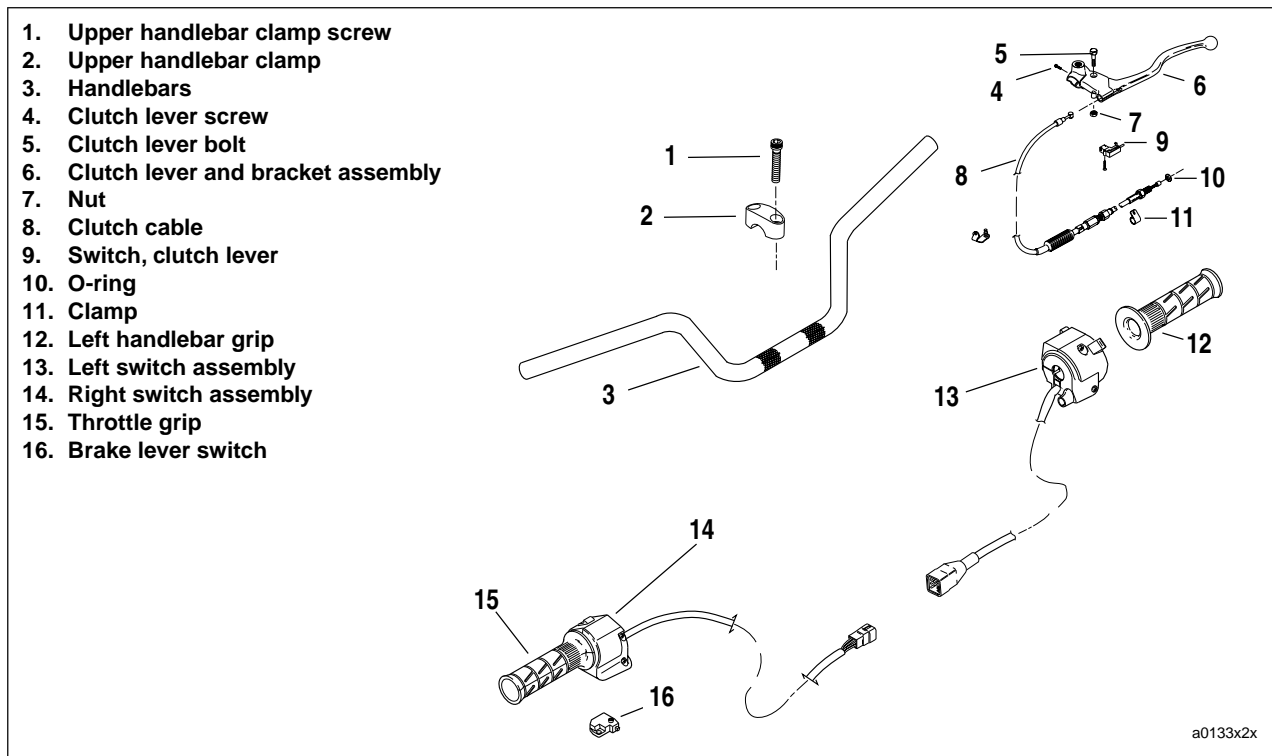


Figure 2-119. Handlebar Assembly

FRONT ISOLATOR

Removal

1. Remove seat. See [2.28 SEAT](#).
2. Remove fuel tank. See [4.2 FUEL TANK COVER/FUEL TANK](#).
3. Raise motorcycle until front suspension is unloaded.
4. Remove muffler, and support motor with jack. When isolator is detached, powertrain may move. See [2.20 EXHAUST SYSTEM](#).
5. Cut horn cable strap.
6. Remove clutch cable tie.
7. See [Figure 2-120](#). Loosen front ground strap bolt for clearance.
8. See [Figure 2-121](#). Remove two outboard isolator bolts (1).
9. Remove main isolator bolt and nut (2). Discard nut.
10. Remove isolator.

Installation

1. See [Figure 2-121](#). Position **new** isolator in frame.
2. Install two outboard isolator bolts (1). Tighten 30-33 ft-lbs (41-45 Nm).
3. Install main isolator bolt and **new** nut (2). Tighten main isolator bolt to 63-70 ft-lbs (85-95 Nm).
4. Tighten front ground strap bolt to 30-33 ft-lbs (41-45 Nm).
5. Install clutch cable to clip.
6. Install horn cable strap.
7. Install fuel tank. See [4.2 FUEL TANK COVER/FUEL TANK](#).

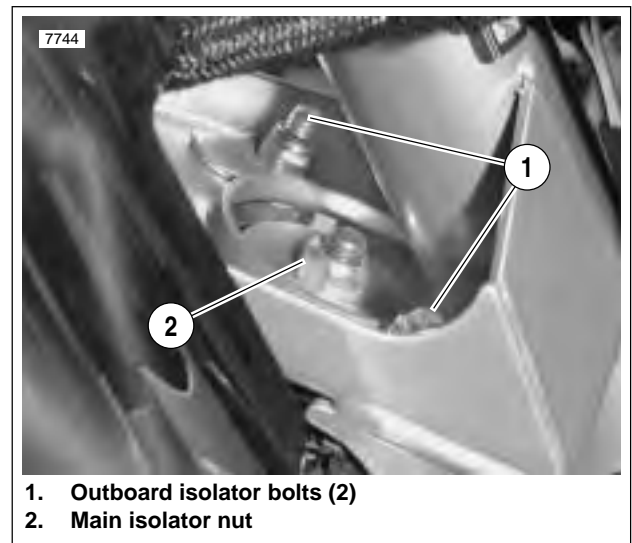
WARNING

After installing seat, pull upward on front of seat to be sure it is in locked position. While riding, a loose seat can shift causing loss of control, which could result in death or serious injury. (00070a)

8. Install seat. See [2.28 SEAT](#).



Figure 2-120. Front Ground Strap Bolt



1. Outboard isolator bolts (2)
2. Main isolator nut

Figure 2-121. Front Isolator Bolts

REAR ISOLATOR

Removal

1. Remove seat. See [2.28 SEAT](#).

⚠ WARNING

Disconnect negative (-) battery cable first. If positive (+) cable should contact ground with negative (-) cable connected, the resulting sparks can cause a battery explosion, which could result in death or serious injury. (00049a)

2. Remove battery. See [7.16 BATTERY](#).
3. Support rear of motorcycle.
4. Remove rear shock. See [2.15 REAR SHOCK ABSORBER](#).
5. Remove muffler and support motor with jack. When isolator is detached powertrain may move. See [2.20 EXHAUST SYSTEM](#)
6. See [Figure 2-122](#). Remove two allen bolts connecting frame to isolator.
7. See [Figure 2-123](#). Remove four bolts (2) connecting isolator (1) to engine.

NOTE

It may be necessary to raise or lower motorcycle to remove isolator.

Installation

1. See [Figure 2-123](#). Clean engine bolt holes and bolts. Do not re-tap holes.
2. Apply Loctite 243 (blue) to bolts and install four isolator-to-engine bolts. Tighten bolts to 23-27 ft-lbs (31.2-36.6 Nm).
3. See [Figure 2-122](#). Apply Loctite Threadlocker 271 (red) to the two frame-to-isolator bolts. Tighten bolts to 30-33 ft-lbs (41-45 Nm).
4. Install rear shock absorber. See [2.15 REAR SHOCK ABSORBER](#).

⚠ WARNING

Connect positive (+) battery cable first. If positive (+) cable should contact ground with negative (-) cable connected, the resulting sparks can cause a battery explosion, which could result in death or serious injury. (00068a)

5. Install battery. See [7.16 BATTERY](#).

⚠ WARNING

After installing seat, pull upward on front of seat to be sure it is in locked position. While riding, a loose seat can shift causing loss of control, which could result in death or serious injury. (00070a)

6. Install seat. See [2.28 SEAT](#).

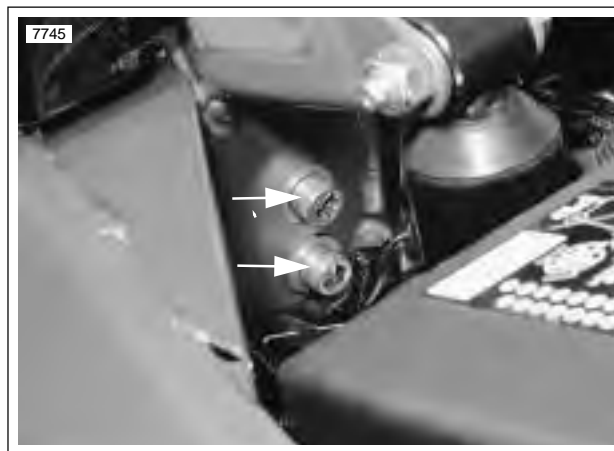


Figure 2-122. Frame-to-Isolator Bolts

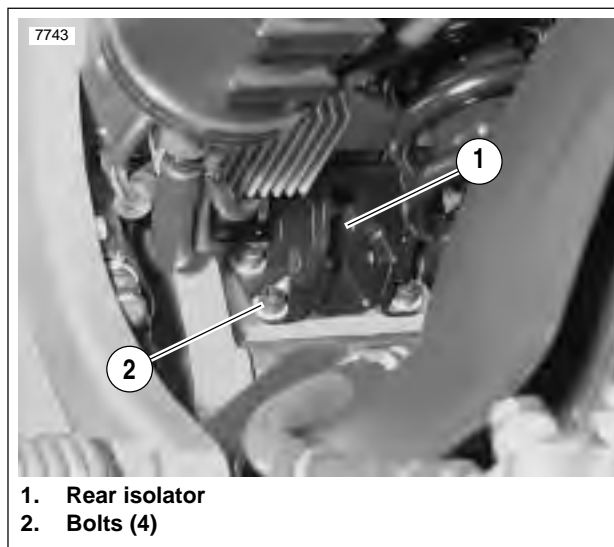


Figure 2-123. Rear Engine Mount Isolator

SUBJECT	page NO.
3.1 Specifications	3-1
3.2 Engine	3-6
3.3 Stripping Motorcycle For Engine Service	3-8
3.4 Engine Installation	3-16
3.5 Cylinder Head	3-24
3.6 Cylinder And Piston	3-40
3.7 Lubrication System	3-51
3.8 Oil Reservoir and Oil Hose Routing	3-52
3.9 Oil Pressure Indicator Switch	3-54
3.10 Crankcase Breathing System	3-55
3.11 Oiling System	3-56
3.12 Oil Pump	3-57
3.13 Oil Filter Mount	3-60
3.14 Hydraulic Lifters	3-61
3.15 Gearcase Cover and Cam Gears	3-63
3.16 Crankcase	3-67

NOTE

Service wear limits are given as a guideline for measuring components that are not **new**. For measurement specifications not given under SERVICE WEAR LIMITS, see NEW COMPONENTS.

Table 3-1. General Specifications

GENERAL		
Type	Single cylinder, air cooled, four-stroke	
Compression Ratio	9.2: 1	
Bore	3.50 in.	88.8 mm
Stroke	3.125 in.	79.375 mm
Engine Displacement	30 cu. in.	492 cc
Oil Capacity (with filter change)	2.0 quarts	1.89 liters

Table 3-2. Ignition Specifications

ENGINE IGNITION SPECIFICATIONS	
Timing Advance (during engine cranking)	1° BTDC
Timing Advance (at 1200 RPM)	20° BTDC
Regular Idle	1200 RPM
Fast Idle	2000 RPM

Table 3-3. Valve and Valve Seat Specifications

VALVE		NEW COMPONENTS		SERVICE WEAR LIMITS	
		inches	mm	inches	mm
Fit in guide	Exhaust	0.0015-0.0033	0.0381-0.0838	0.0040	0.1016
	Intake	0.0008-0.0026	0.0200-0.0700	0.0035	0.0889
Seat width		0.040-0.062	1.016-1.575	0.090	2.286
Stem protrusion from cylinder valve pocket		1.975-2.011	50.165-51.079	2.031	51.587

Table 3-4. Outer Valve Spring Specifications

OUTER VALVE SPRING		NEW COMPONENTS		SERVICE WEAR LIMITS	
Free length		2.105-2.177 in.	53.467-55.296 mm	2.105 in. (min)	53.467 mm (min)
Intake	1.751-1.848 in. (closed)	72-92 lbs	33-42 kg		
	1.286-1.383 in. (open)	183-207 lbs	83-94 kg		
Exhaust	1.751-1.848 in. (closed)	72-92 lbs	33-42 kg		
	1.332-1.429 in. (open)	171-195 lbs	78-88 kg		

Table 3-5. Inner Valve Spring Specifications

INNER VALVE SPRING		NEW COMPONENTS		SERVICE WEAR LIMITS	
Free length		1.926-1.996 in.	48.920-50.698 mm	1.926 in. (min)	48.920 mm (min)
Intake	1.577-1.683 in. (closed)	38-49 lbs	17-22 kg		
	1.112-1.218 in. (open)	98-112 lbs	44-51 kg		
Exhaust	1.577-1.683 in. (closed)	38-49 lbs	17-22 kg		
	1.158-1.264 in. (open)	91-106 lbs	41-48 kg		

Table 3-6. Rocker Arm Specifications

ROCKER ARM	NEW COMPONENTS		SERVICE WEAR LIMITS	
	inches	mm	inches	mm
Shaft fit in bushing (loose)	0.0005-0.0020	0.0127-0.0508	0.0035	0.0889
End clearance	0.003-0.013	0.076-0.330	0.025	0.635
Bushing fit in rocker arm (tight)	0.004-0.002	0.102-0.0559		
Rocker arm shaft fit in rocker cover (loose)	0.0007-0.0022	0.018-0.056	0.0035	0.0889

Table 3-7. Piston Specifications

PISTON	NEW COMPONENTS		SERVICE WEAR LIMITS		
	inches	mm	inches	mm	
Compression ring gap (top and 2nd)	0.007-0.020	0.178-0.508	0.032	0.813	
Oil control ring rail gap	0.009-0.052	0.229-1.321	0.065	1.651	
Compression ring side clearance	Top	0.0020-0.0045	0.0508-0.1143	0.0065	0.1651
	2nd	0.0016-0.0041	0.0410-0.1041	0.0065	0.1651
Oil control ring side clearance	0.0016-0.0076	0.0410-0.1930	0.0094	0.2390	
Pin fit (loose, at room temperature)	0.0005-0.00045	0.0130-0.0110	0.00100	0.02500	

Table 3-8. Cylinder Head Specifications

CYLINDER HEAD	NEW COMPONENTS		SERVICE WEAR LIMITS	
	inches	mm	inches	mm
Valve guide in head (tight)	0.0033-0.0020	0.0838-0.0508		
Valve seat in head (tight)	0.0035-0.0010	0.0889-0.0254		
Head gasket surface (flatness)	0.006 total	0.152 total	0.006 total	0.152 total

Table 3-9. Cylinder Specifications

CYLINDER		NEW COMPONENTS		SERVICE WEAR LIMITS	
		inches	mm	inches	mm
Taper				0.002	0.051
Out of round				0.003	0.076
Warpage (gasket surfaces)	Top			0.006	0.152
	Base			0.008	0.203
Bore diameter ± 0.0002 in.	Standard	3.4978	88.8441	3.5008	88.9203
	0.005 OS	3.502	88.951	3.5050	89.0270
	0.010 OS	3.507	89.078	3.5100	89.1540
OS=over size	0.020 OS	3.517	89.332	3.5200	89.4080
	0.030 OS	3.527	89.586	3.5300	89.6620

Table 3-10. Connecting Rod Specifications

CONNECTING ROD	NEW COMPONENTS		SERVICE WEAR LIMITS	
	inches	mm	inches	mm
Piston pin fit (loose)	0.00125-0.00175	0.03175-0.04445	0.00200	0.05080
Side play between flywheels	0.005-0.025	0.127-0.635	0.030	0.762
Fit on crankpin (loose)	0.0004-0.0017	0.0102-0.0432	0.0027	0.0686
Connecting rod race ID	1.6245-1.6250	41.2623-41.2750	1.6270	41.3258

Table 3-11. Hydraulic Lifter Specifications

HYDRAULIC LIFTER	NEW COMPONENTS		SERVICE WEAR LIMITS	
	inches	mm	inches	mm
Fit in guide	0.0008-0.0020	0.0203-0.0508	0.0030	0.0762
Roller fit	0.0006-0.0010	0.0152-0.0254	0.0015	0.0381
Roller end clearance	0.008-0.022	0.203-0.559	0.026	0.660

Table 3-12. Oil Pump Specifications

OIL PUMP		NEW COMPONENTS		SERVICE WEAR LIMITS	
Oil pressure	1000 RPM	7-12 PSI	48-83 KPa		
	2500 RPM	10-17 PSI	69-117 KPa		
Shaft to pump clearance		0.0025 in.	0.0635 mm		
Feed/scavenge inner/outer gerotor clearance		0.003 in.	0.076 mm	0.004 in.	0.102 mm

Table 3-13. Gearcase Specifications

GEARCASE	NEW COMPONENTS		SERVICE WEAR LIMITS	
	inches	mm	inches	mm
Cam gear shaft in bushing (loose)	0.0007-0.0022	0.0178-0.0559	0.003	0.076
Cam gear shaft end play (min)	0.005-0.024	0.127-0.610	0.025	0.635
Intake cam gear shaft end play (min)	0.006-0.024	0.152-0.610	0.040	1.016

Table 3-14. Flywheel Specifications

FLYWHEEL		NEW COMPONENTS		SERVICE WEAR LIMITS	
		inches	mm	inches	mm
Runout	Flywheels at rim	0.000-0.010	0.000-0.254	0.010	0.254
	Shaft at flywheel end	0.000-0.002	0.000-0.051	0.002	0.051
End play		0.001-0.005	0.025-0.127	0.005	0.127

Table 3-15. Sprocket Shaft Bearing Specifications

SPROCKET SHAFT BEARING	NEW COMPONENTS		SERVICE WEAR LIMITS	
	inches	mm	inches	mm
Outer race fit in crankcase (tight)	0.0004-0.0024	0.0102-0.0610		
Bearing inner race fit on shaft (tight)	0.0002-0.0015	0.0051-0.0381		

Table 3-16. Pinion Shaft Bearing Specifications

PINION SHAFT BEARINGS	NEW COMPONENTS		SERVICE WEAR LIMITS	
	inches	mm	inches	mm
Pinion shaft journal diameter	1.2496-1.2500	31.7398-31.7500	1.2496 (min)	31.7398 (min)
Outer race diameter in right crankcase	1.5646-1.5652	39.7408-39.7561	1.5672 (max)	39.8069 (max)
Bearing running clearance	0.00012-0.00088	0.00305-0.02235		
Fit in cover bushing (loose)	0.0023-0.0043	0.0584-0.1092	0.0050	0.1270

TORQUE VALUES

ITEM	TORQUE		NOTES
Air cleaner bracket fasteners to air cleaner	36-60 in-lbs	4.1-6.8 Nm	Page 3-21
Anti-rotation screws (lifter)	55-65 in-lbs	6-7 Nm	Page 3-62
Crankcase 5/16 in. screws	15-19 ft-lbs	20-26 Nm	Page 3-80
Crankcase, 3/8 in. screw	22-27 ft-lbs	30-37 Nm	Page 3-80
Cylinder studs	10-20 ft-lbs	14-27 Nm	Special method to tighten, Page 3-81
Flywheel - sprocket nut (for measuring fly-wheel end play)	190-210 ft-lbs	258-285 Nm	Page 3-67
Frame to rear isolator fastener	30-33 ft-lbs	41-45 Nm	Loctite Threadlocker 271 (red), Page 3-17
Front isolator mounting bolt	63-70 ft-lbs	86-95 Nm	Loctite Threadlocker 271 (red), Page 3-23
Front tie bar	30-33 ft-lbs	41-45 Nm	Loctite Threadlocker 271 (red), Page 3-22
Gearcase cover screws	80-110 in-lbs	9-12 Nm	Special pattern to tighten, Page 3-66
Ground strap bolt to engine	30-33 ft-lbs	41-45 Nm	Page 3-22
Master cylinder mounting screws	48-72 in-lbs	5-8 Nm	Loctite 243 (blue), Page 3-20
Oil filter adapter	96-144 in-lbs	11-16 Nm	Loctite 243 (blue), Page 3-60
Oil pressure signal light switch	50-70 in-lbs	6-8 Nm	Page 3-60
Oil pump cover screws	70-80 in-lbs	8-9 Nm	TORX, page 3-59
Oil pump mounting screws	125-150 in-lbs	14-17 Nm	Page 3-59
Pinion shaft nut	19-21 ft-lbs	26-29 Nm	Page 3-65
Piston jet TORX screws	25-35 in-lbs	2.8-4 Nm	Loctite 222, Page 3-76
Pushrod cover screw	30-40 in-lbs	3-5 Nm	Page 3-62
Rear engine isolator engine to crankcase	23-27 ft-lbs	31-37 Nm	Loctite 243 (blue), Page 3-16
Rocker box cover screws	120-168 in-lbs	13.6-17.6 Nm	Page 3-39
Rocker box to head bolts	135-155 in-lbs	15-18 Nm	1/4-20 X 1-1/2, Page 3-39
Rocker box to head bolts	135-155 in-lbs	15-18 Nm	1/4-20 X 1-1/4, Page 3-39
Rocker box to head bolts	18-22 ft-lbs	24-30 Nm	5/16-18 X 2-1/2, Page 3-39
Side stand bracket	38-41 ft-lbs	51-55 Nm	Loctite Threadlocker 271 (red), Page 3-16
Swing arm pinch bolt	17-19 ft-lbs	23-26 Nm	Loctite 243 (blue), Page 3-16
Swing arm pivot shaft	24-26 ft-lbs	32-35 Nm	Page 3-16
Top rear tie bar	30-33 ft-lbs	41-45 Nm	Loctite Threadlocker 271 (red), Page 3-22

FUEL

Gasoline/alcohol Blends

The Buell Blast P3 motorcycle has been designed to obtain the best performance and efficiency using unleaded gasoline (**87 pump octane** or higher). Some fuel suppliers sell gasoline/alcohol blends as a fuel. The type and amount of alcohol added to the fuel is important.

- DO NOT USE GASOLINES CONTAINING METHANOL. Using gasoline/methanol blends will result in starting and driveability deterioration and damage to critical fuel system components.
- Gasolines containing ETHANOL: Gasoline/ethanol blends are mixture of 10% ethanol (Grain alcohol) and 90% unleaded gasoline. Gasoline/ethanol blends can be used in your motorcycle if the ethanol content does not exceed 10%.
- REFORMULATED OR OXYGENATED GASOLINES (RFG): "Reformulated gasoline" is a term used to describe gasoline blends that are specifically designed to burn cleaner than other types of gasoline, leaving fewer "tailpipe" emissions. They are also formulated to evaporate less when you are filling your tank. Reformulated gasolines use additives to "oxygenate" the gas. Your motorcycle will run normally using this type of gas. Buell recommends you use it when possible, as an aid to cleaner air in our environment.

Because of their generally higher volatility, these blends may adversely affect the starting, driveability and fuel efficiency of your motorcycle. If you experience these problems, Buell recommends that you operate your motorcycle on straight, unleaded gasoline.

LUBRICATION

The engine has a force-feed (pressure) type oiling system, incorporating oil feed and return pumps in one pump body, with one check valve on the oil feed side. The feed pump forces oil to the engine, lubricating lower connecting rod bearings, rocker arm bushings, valve stems, valve springs, push rods and tappets. Cylinder wall, piston, piston pin, timing gears, bushings and main bearings are lubricated by oil spray thrown off connecting rods and crankshaft, and by oil draining from each rocker box through an internal drain passage in each cylinder and each tappet guide. Oil is transferred to the teeth of all the cam gears by way of the gear meshing action. The oil-scavenging section of the pump returns oil to the tank from the engine. See [3.7 LUBRICATION SYSTEM](#) for more information.

ADJUSTMENT/TESTING

General

When an engine needs repair, it is not always possible to determine definitely beforehand whether repair is possible with only cylinder head, cylinder and piston disassembled or

whether complete engine disassembly is required for crankcase repair.

Most commonly, only cylinder head and cylinder repair is needed (valves, rings, piston, etc.) and it is recommended procedure to service these units first, allowing engine crankcase to remain in frame.

See [DISASSEMBLY](#) under [3.3 STRIPPING MOTORCYCLE FOR ENGINE SERVICE](#) to strip motorcycle for removal of cylinder head, cylinder, and piston.

After disassembling "upper end" only, it may be found that crankcase repair is necessary. In this situation, remove the engine crankcase from the chassis.

IMPORTANT NOTE

If engine is removed from chassis, do not lay engine on primary side. Placing engine on primary side will damage clutch cable end fitting. If fitting is damaged, clutch cable must be replaced.

See [1.24 TROUBLESHOOTING](#) section. Symptoms indicating a need for engine repair are often misleading, but generally, if more than one symptom is present, possible causes can be narrowed down to make at least a partial diagnosis. An above-normal consumption of oil, for example, could be caused by several mechanical faults. However, when accompanied by blue-gray exhaust smoke and low engine compression, it indicates the piston rings need replacing. Low compression by itself, however, may indicate improperly seated valves, in addition to or in lieu of worn piston rings.

Most frequently, valves, rings, pins, bushings, and bearings need attention at about the same time. If the possible causes can be narrowed down through the process of elimination to indicate any one of the above components is worn, it is best to give attention to all of the cylinder head and cylinder parts.

Compression Test Procedure

Combustion chamber leakage can result in unsatisfactory engine performance. A compression test can help determine the source of cylinder leakage. Use CYLINDER COMPRESSION GAUGE (Part No. HD-33223-1).

A proper compression test should be performed with the engine at normal operating temperature when possible. Proceed as follows:

IMPORTANT NOTE

After completing the compression test(s), make sure that the throttle plate is in the closed position before starting engine. Engine will start at an extremely high RPM if throttle plate is left open.

1. Disconnect spark plug wire. Clean around plug base and remove plug.
2. Connect compression tester to cylinder.
3. With carburetor throttle plates in wide open position, crank engine continuously through 5-7 full compression strokes.
4. Note gauge readings at the end of the first and last compression strokes. Record test results.
5. Compression is normal if final readings are 120 psi (827 kPa) or more.
6. Inject approximately 1/2 oz. (15 ml) of SAE 30 oil into cylinder and repeat the compression test. Readings that are considerably higher during the second test indicate worn piston rings.

Table 3-17. Compression Test Results

DIAGNOSIS	TEST RESULTS
Ring trouble	Compression low on first stroke; tends to build up on the following strokes but does not reach normal; improves considerably when oil is added to cylinder.
Valve trouble	Compression low on first stroke; does not build up much on following strokes; does not improve considerably with the addition of oil.
Head gasket leak	Same reaction as valve trouble.

Cylinder Leakage Test

The cylinder leakage test pinpoints engine problems including leaking valves, worn, broken or stuck piston rings and blown head gaskets. The cylinder leakage tester applies compressed air to the cylinder at a controlled pressure and volume, and measures the percent of leakage from the cylinder.

Use a CYLINDER LEAKDOWN TESTER (Part No. HD-35667A) and follow the specific instructions supplied with the tester.

The following are some general instructions that apply to Buell motorcycle engines:

1. Run engine until it reaches normal operating temperature.

2. Stop engine. Clean dirt from around spark plug and remove spark plug.
3. Remove air cleaner and set carburetor throttle in wide open position.
4. Remove timing inspection plug from crankcase.
5. The piston, in cylinder being tested, must be at top dead center of compression stroke during test.
6. To keep engine from turning over when air pressure is applied to cylinder, engage transmission in fifth gear and lock the rear brake.
7. Following the manufacturer's instructions, perform a cylinder leakage test on the front cylinder. Make a note of the percent leakdown. Any cylinder with 12% leakdown, or more, requires further attention.
8. Refer to [Table 3-18](#). Listen for air leaks at carburetor intake, exhaust, head gasket and timing inspection hole.

NOTE

If air is escaping through valves, check push rod length.

IMPORTANT NOTE

After completing the compression test(s), make sure that the throttle plate is in the closed position before starting engine. Engine will start at an extremely high RPM if throttle plate is left open.

Table 3-18. Air Leakage Test

AIR LEAK LOCATION	POSSIBLE CAUSES
Carburetor intake	Intake valve leaking.
Exhaust pipe	Exhaust valve leaking.
Timing inspection hole	Piston rings leaking. Worn or broken piston. Worn cylinder.
Head gasket	Leaking gasket.

Diagnosing Smoking Engine or High Oil Consumption

Perform [Compression Test Procedure](#) or [Cylinder Leakage Test](#) as described previously. If further testing is needed, remove suspect head(s) and inspect the following:

- Valve guide seals.
- Valve guide-to-valve stem clearance.
- Gasket surface of both head and cylinder.

DISASSEMBLY

1. Lift and secure the motorcycle by placing the vehicle on a lift and anchor rear wheel in place. Raise lift so the top of the cylinder head is easy to access.
2. Remove seat. See [2.28 SEAT](#).

WARNING

To prevent accidental vehicle start-up, which could cause death or serious injury, disconnect negative (-) battery cable before proceeding. (00048a)

WARNING

Disconnect negative (-) battery cable first. If positive (+) cable should contact ground with negative (-) cable connected, the resulting sparks can cause a battery explosion, which could result in death or serious injury. (00049a)

3. Disconnect **both** battery cables, negative cable first. See [7.16 BATTERY](#).
4. Remove fuel tank. See [7.16 BATTERY](#).
5. Remove muffler. See [2.20 EXHAUST SYSTEM](#).
6. Place jack under the motor. Use jack to lower motor.
7. Remove horn. See [7.22 HORN](#).
8. See [Figure 3-1](#). Remove crankcase breather hose and crankcase breather from rocker box grommet.

IMPORTANT NOTE

See [Figure 3-2](#). Do not attempt to remove isolator mount from cylinder head. Isolator mount is an integral component and is not meant to be removed unless absolutely necessary. Repeated removals and installations will damage cylinder head threads.

NOTES:

- Remove the isolator mount **ONLY** to replace the engine, cylinder head or servicing of exhaust valve components. For all other disassembly and servicing do not remove mount from cylinder head.
 - Proceed to step 9. for engine removal, cylinder head replacement or complete cylinder head servicing including exhaust valve components.
 - For all other disassembly and related servicing procedures proceed to step 10.
9. See [Figure 3-2](#). Remove the two mounted cylinder head bolts from the front isolator/engine bracket marked "DO NOT REMOVE". See note above.

NOTES

- For top end service proceed to step 11.
- For engine removal proceed to step 12.



Figure 3-1. Remove Crankcase Breather Hose



Figure 3-2. Cylinder Head Bolts

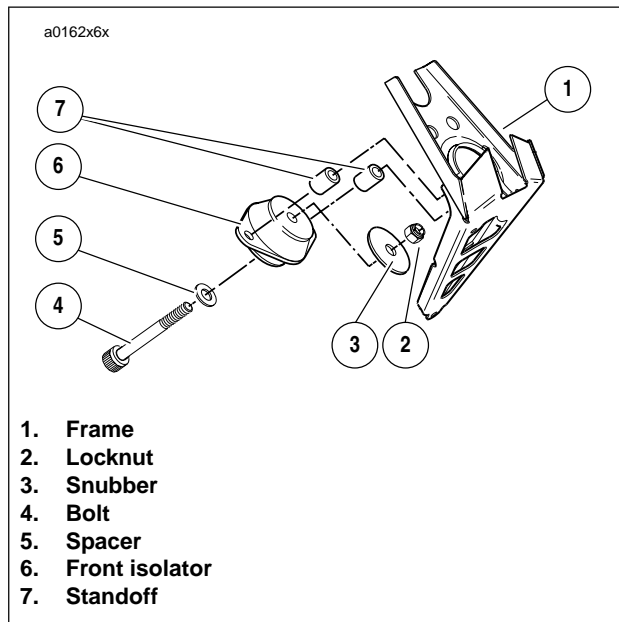


Figure 3-3. Front Isolator Mount

10. See [Figure 3-3](#). Loosen and remove front isolator mount bolt, spacer, snubber and locknut.
11. For top end service loosen, but do not remove lower front tie bar bolts at engine and frame.
12. For engine removal, loosen and remove lower front tie bar from engine.



Figure 3-4. Remove Top Rear Tie Bar

13. See [Figure 3-4](#). Remove top rear tie bar at frame.

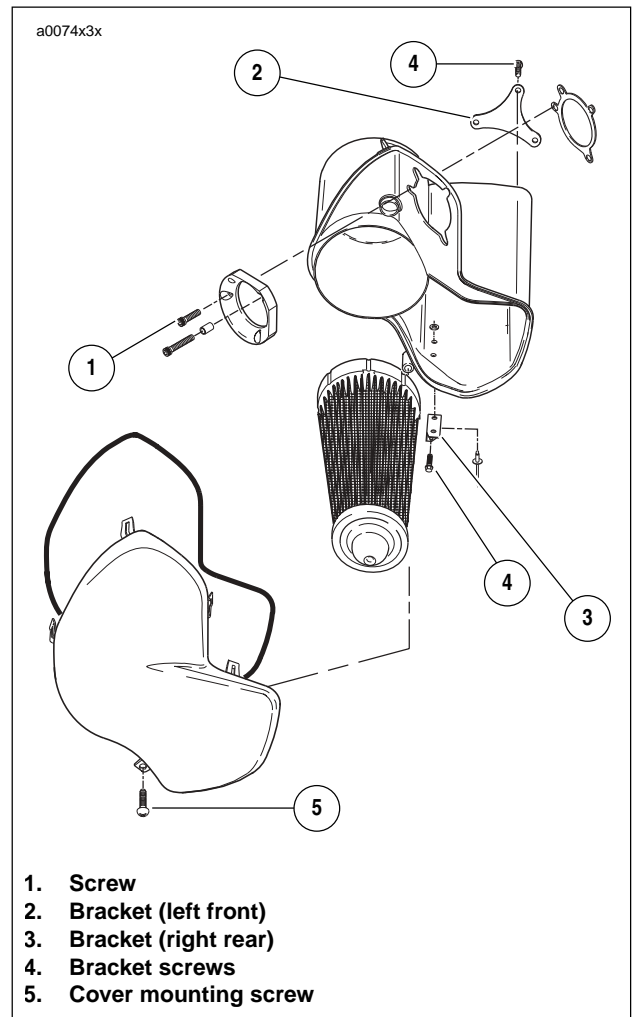


Figure 3-5. Air Cleaner Assembly

NOTE

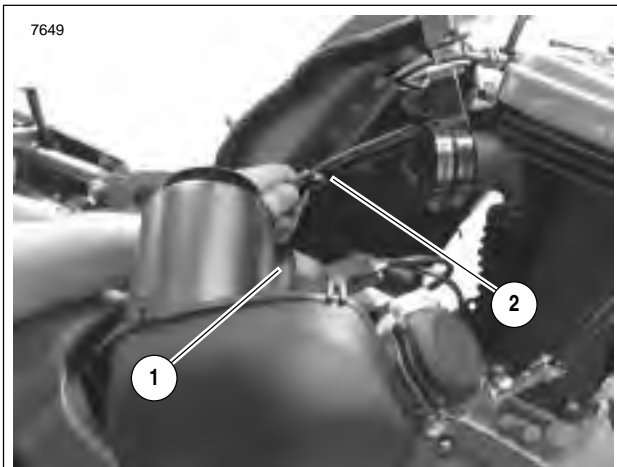
Remove entire air cleaner and carburetor as an assembly.

14. See [Figure 3-5](#). Remove screws (4) on both air cleaner brackets (2,3).



Figure 3-6. Hose Clamp

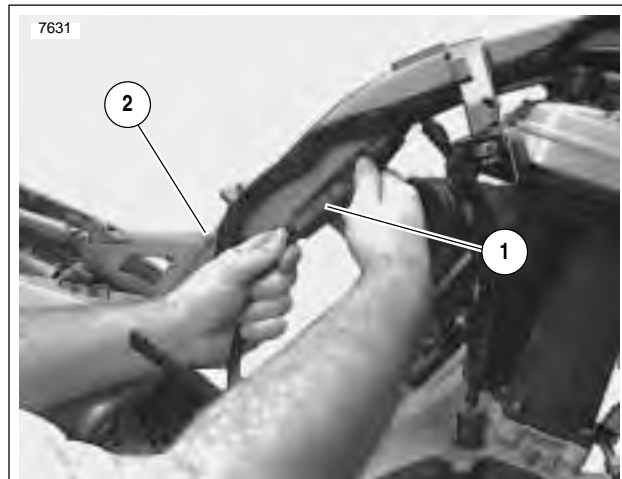
15. See [Figure 3-6](#). Loosen hose clamp.



1. Breather hose
2. Three-way connector

Figure 3-7. Crankcase Breather Hose

16. See [Figure 3-7](#). Remove crankcase breather hose.



1. Auto-enrichener plug
2. Frame

Figure 3-8. Auto-Enrichener Plug

17. See [Figure 3-8](#). Disconnect auto-enrichener plug.
18. Place air cleaner and carburetor as an assembly on top of frame.

NOTES

- For more details about the air cleaner see [4.3 AIR CLEANER](#).
- The steps mentioned previously complete disassembly preparation for top end servicing. You may now proceed with [TOP END DISASSEMBLY PROCEDURES](#). See [3.5 CYLINDER HEAD](#).
- If continuing engine removal proceed to step 20.

NOTE

The remaining steps are required to complete engine removal.

19. Place jack under the motor. Use jack to lower motor.
20. Move jack forward.
21. Place wooden cradle under engine.

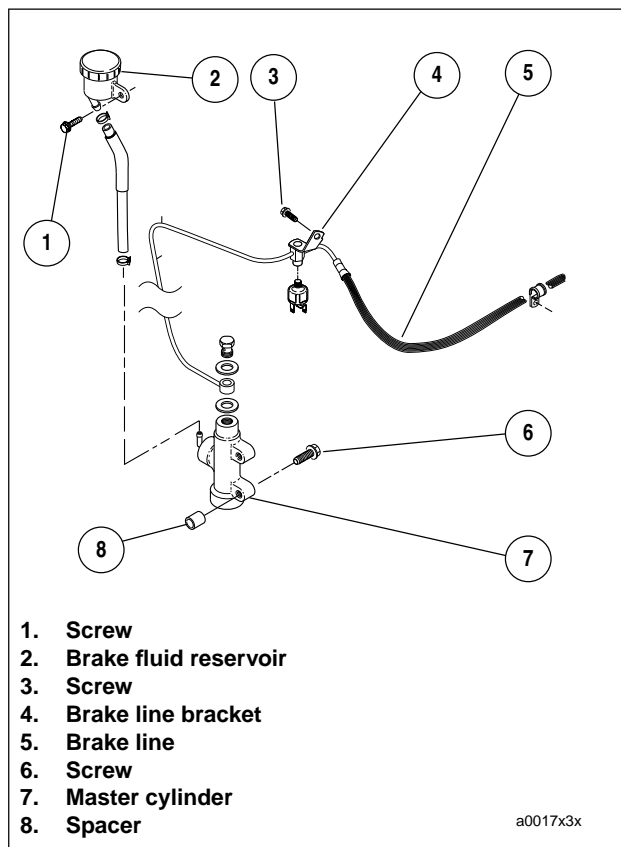


Figure 3-9. Rear Master Cylinder and Brake Line Assembly

NOTE

See [Figure 3-9](#). Remove rear master cylinder before removing sprocket cover.

22. Remove sprocket cover. See [2.22 SPROCKET COVER](#).
23. See [Figure 3-9](#). Disconnect screws (1, 3, 6) at brake fluid reservoir, master cylinder and brake line bracket.
24. Move belt on rear sprocket off pulley toward inside of motorcycle.

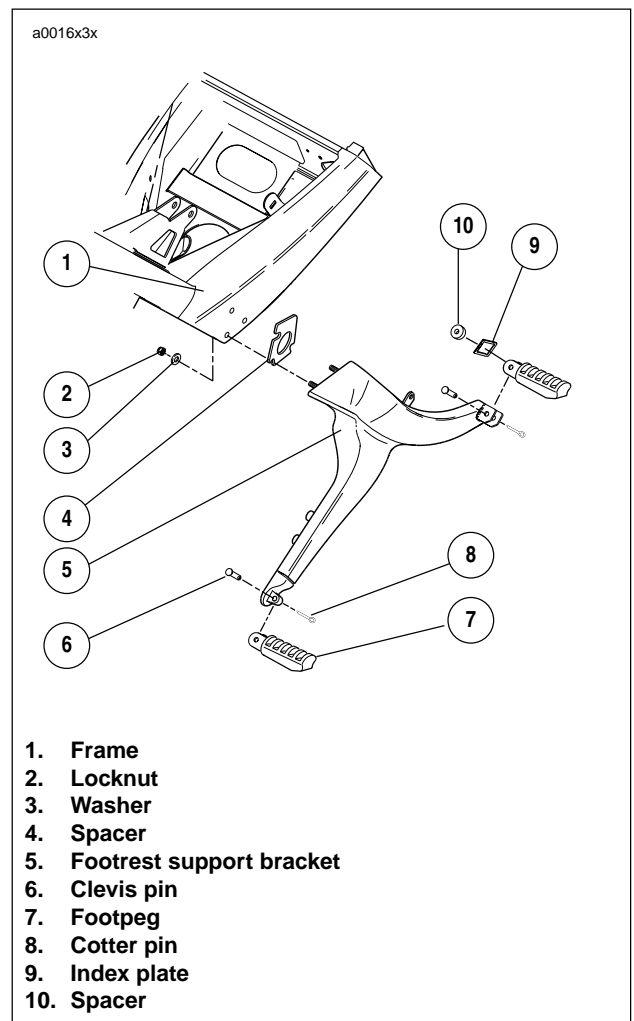


Figure 3-10. Footpeg Bracket Assembly

25. See [Figure 3-10](#). Remove right side rider footpeg bracket assembly. See [2.21 FOOTPEGS AND FOOTPEG SUPPORT BRACKETS](#).
26. Introduce freeplay and remove clutch cable at hand lever location. See [1.9 CLUTCH](#).
27. Refer to [Table 3-19](#). Disconnect the following electrical items.

Table 3-19. Electrical Items Disconnected for Engine Disassembly

DESCRIPTION	LOCATION
Ignition module [10]	Located on frame backbone.
Speedo sensor [65]	Located under seat (right side-tucked in under cavity).
Sidestand switch [60]	Tie wrapped to rear brake line.
Neutral switch [131]	Disconnect at neutral switch.
Oil pressure switch [120]	Disconnect at oil pressure switch.
Alternator stator [46]	Located under seat (left side).
Starter solenoid wire [128]	Disconnect at starter.
Spark plug wire	Located on spark plug.
Battery—positive wire	Disconnect at main circuit breaker.
Rear brake light switch [121]	Located under frame by shock absorber.



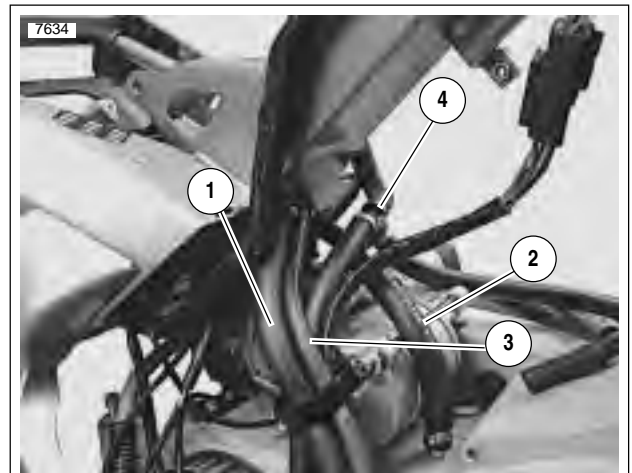
Figure 3-11. Hoisting Bike

28. See [Figure 3-11](#). Place a floor hoist behind the lift. Attach straps to frame and hoist. Raise hoist until straps tighten.
29. Remove rear shock. See [2.15 REAR SHOCK ABSORBER](#).



Figure 3-12. Loosen Clamp

30. See [Figure 3-12](#). Loosen nut on hose routing clamp.



1. Oil return
2. Transmission vent
3. Crankcase vent
4. Oil feed

Figure 3-13. Disconnect Lines

31. See [Figure 3-13](#). Disconnect feed, return, transmission and crankcase vent lines.



Figure 3-14. Removing Rear Motor Mount Bolts

32. See [Figure 3-14](#). Remove rear motor mount bolts.



Figure 3-15. Move Chassis From Engine

33. Remove chassis from engine by performing the steps below.
 - a. Lower chassis.
 - b. Disconnect hoist from chassis.
 - c. Lower lift.
 - d. See [Figure 3-15](#). Lift chassis and roll away from engine.



Figure 3-16. Air Cleaner Bracket

34. See [Figure 3-16](#). Remove air cleaner box bracket.



Figure 3-17. Rear Engine Mount

35. See [Figure 3-17](#). Remove rear engine mount.

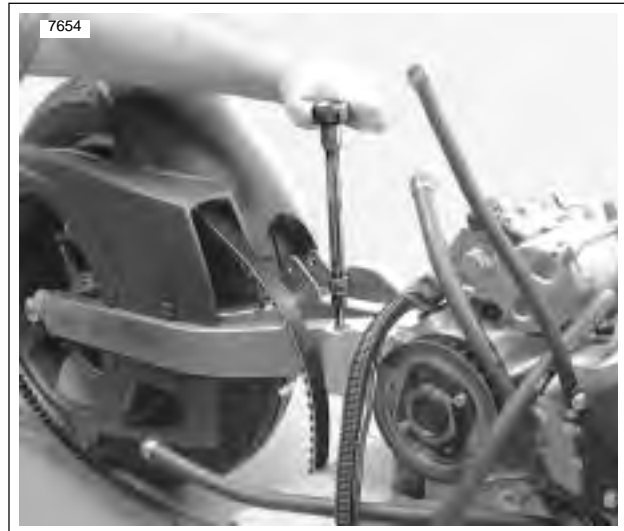


Figure 3-18. Swingarm Pivot Shaft Pinch Bolt

36. See [Figure 3-18](#). Loosen swingarm pinch bolt.

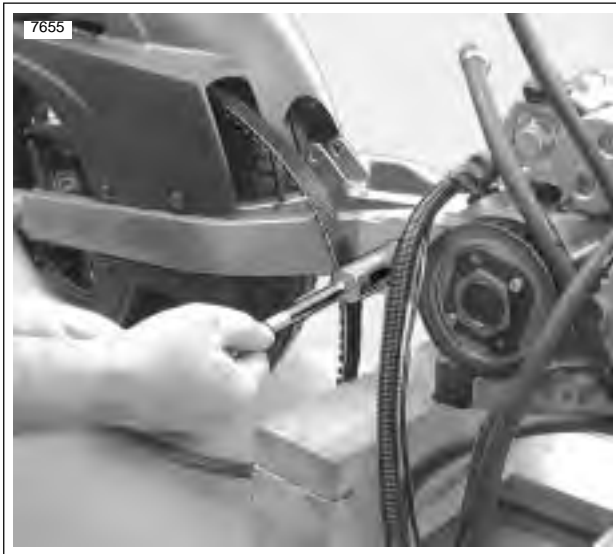


Figure 3-19. Swingarm Pivot Shaft

37. See [Figure 3-19](#). Remove swingarm pivot shaft and rear wheel as an assembly. See [2.19 SWINGARM](#).



Figure 3-20. Sidestand Bracket

38. See [Figure 3-20](#). Remove sidestand and bracket assembly. See [2.29 SIDESTAND](#).

INSTALLING ENGINE

1. Verify cradle is secured under engine.



Figure 3-21. Sidestand Bracket

2. See [Figure 3-21](#). Install sidestand and bracket assembly. See [2.29 SIDESTAND](#).
 - a. Apply several drops of Loctite Threadlocker 271 (red) to last few threads.
 - b. Tighten to 38-41 ft-lbs (51-55 Nm).
3. Install rear wheel. See [2.6 REAR WHEEL](#).

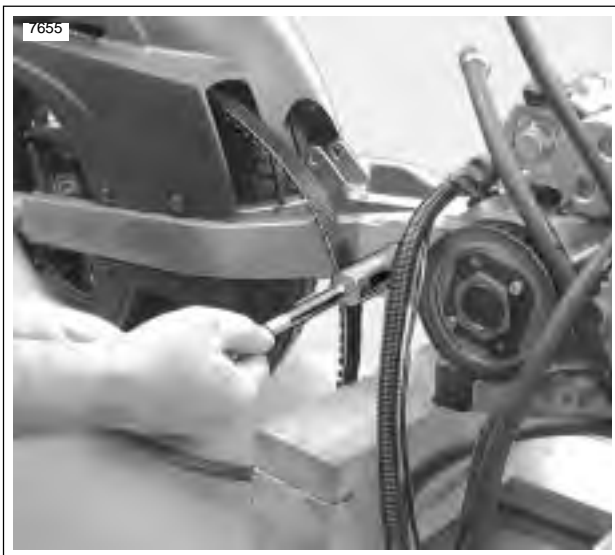


Figure 3-22. Swingarm Pivot Shaft

4. See [Figure 3-22](#). Install swingarm, pivot shaft and rear wheel as an assembly and tighten pivot shaft to 24-26 ft-lbs (32-35 Nm). See [2.19 SWINGARM](#).

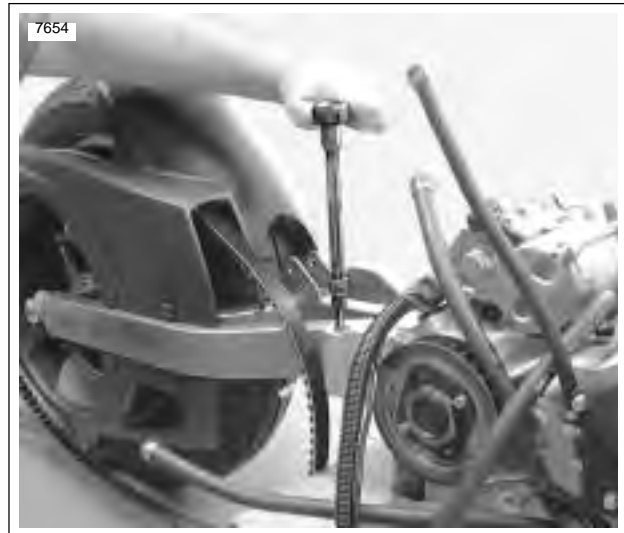


Figure 3-23. Pinch Bolt

5. See [Figure 3-23](#). Install swingarm pinch bolt.
 - a. Apply several drops of Loctite 243 (blue) to last few threads.
 - b. Tighten to 17-19 ft-lbs (23-26 Nm).



Figure 3-24. Rear Engine Mount

6. See [Figure 3-24](#). Install rear engine mount.
 - a. Apply several drops of Loctite 243 (blue) to last few threads.
 - b. Tighten to 23-27 ft-lbs (31-37 Nm).



Figure 3-25. Bracket, Left Side Air Cleaner

7. See [Figure 3-25](#). Loosely install air cleaner box bracket.



Figure 3-26. Move Chassis to Engine

8. See [Figure 3-26](#). Roll chassis toward engine.
 - a. Lift chassis onto engine.
 - b. Raise lift.



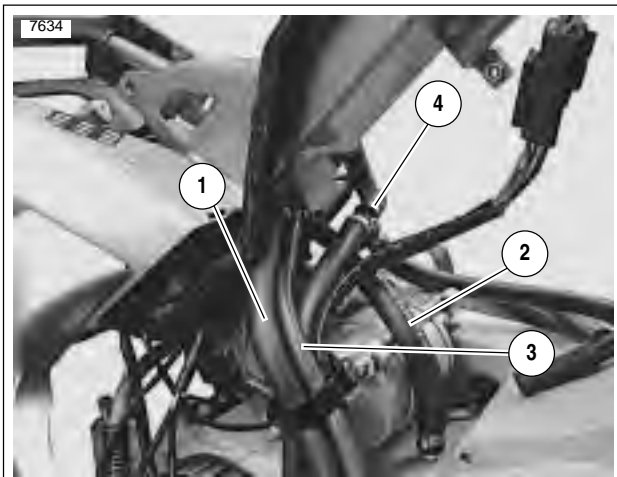
Figure 3-27. Hoisting Bike

9. See [Figure 3-27](#). Attach hoist to frame using straps and raise hoist until straps tighten.
10. Place jack under the motor. Use jack to raise motor.
11. Move jack backward.



Figure 3-28. Installing Rear Motor Mount Bolts

12. See [Figure 3-28](#). Install rear motor mount bolts.
 - a. Apply several drops of Loctite Threadlocker 271 (red) to last few threads.
 - b. Tighten to 30-33 ft-lbs (41-45 Nm).



- 1. Oil return
- 2. Transmission vent
- 3. Crankcase vent
- 4. Feed

Figure 3-29. Connect Lines

13. See [Figure 3-29](#). Connect feed, return, transmission and crankcase vent lines.



Figure 3-30. Tighten Hose Clamps

14. See [Figure 3-30](#). Tighten hose clamps using Hose Clamp Pliers (Part No. HD-41137).



Figure 3-31. Tighten Clamp

15. See [Figure 3-31](#). Tighten nut on hose routing clamp.

16. Install rear shock. See [2.15 REAR SHOCK ABSORBER](#).

17. Refer to [Table 3-20](#). Connect the following electrical items:

Table 3-20. Electrical Items for Engine Assembly

DESCRIPTION	LOCATION
Ignition module [10]	Located on frame backbone.
Speedo sensor [65]	Located under seat (right side-tucked in under cavity).
Sidestand switch [60]	Tie wrapped to rear brake line.
Neutral switch [131]	Disconnect at neutral switch.
Oil pressure switch [120]	Disconnect at oil pressure switch.
Alternator stator [46]	Located under seat (left side).
Starter solenoid wire [128]	Disconnect at starter.
Spark plug wire	Located on spark plug.
Battery—positive wire	Disconnect at main circuit breaker.
Rear brake light switch [121]	Located under frame by shock absorber.

18. Install clutch cable at hand lever location. See 1.9 CLUTCH.
19. Install drive belt. See 1.11 DRIVE BELT AND REAR SPROCKET.
20. Install front sprocket cover. See 2.22 SPROCKET COVER.

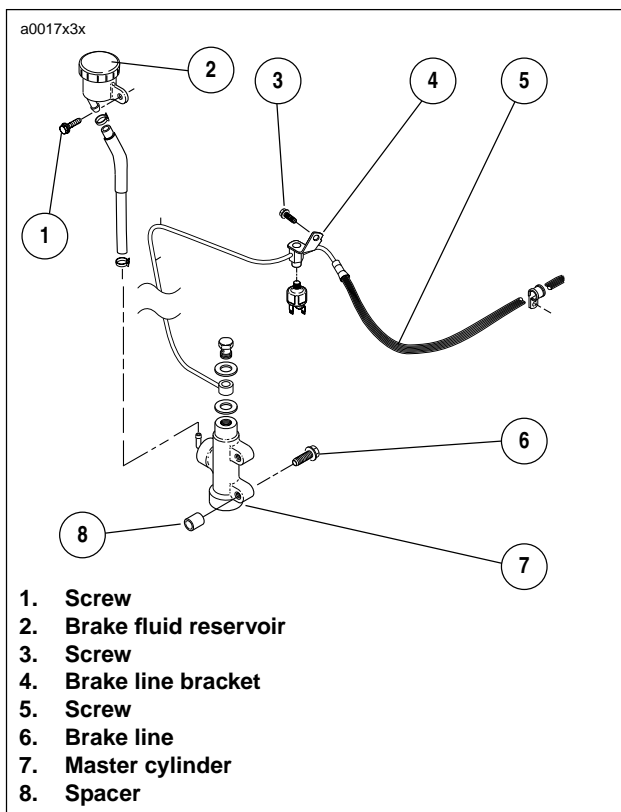


Figure 3-32. Rear Master Cylinder and Brake Line Assembly

21. See Figure 3-32. Install master cylinder onto footpeg bracket. See 2.21 FOOTPEGS AND FOOTPEG SUPPORT BRACKETS.
 - a. Apply several drops of LOCTITE 243 (blue) to last few threads.
 - b. Tighten to 48-72 in-lbs (5-8 Nm).

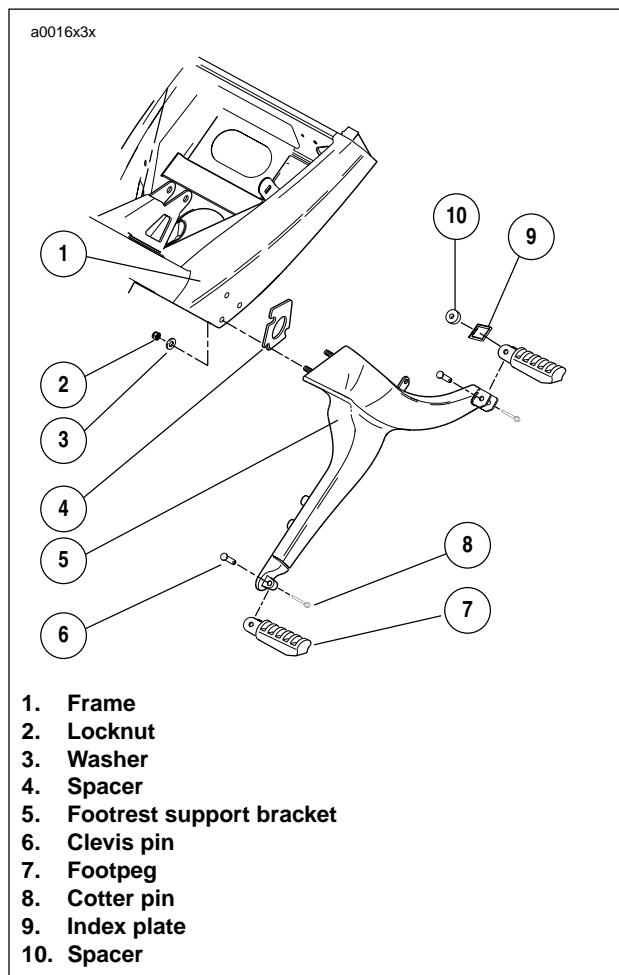


Figure 3-33. Footpeg Bracket Assembly

22. See Figure 3-33. Install right side rider footpeg bracket assembly. See 2.21 FOOTPEGS AND FOOTPEG SUPPORT BRACKETS.

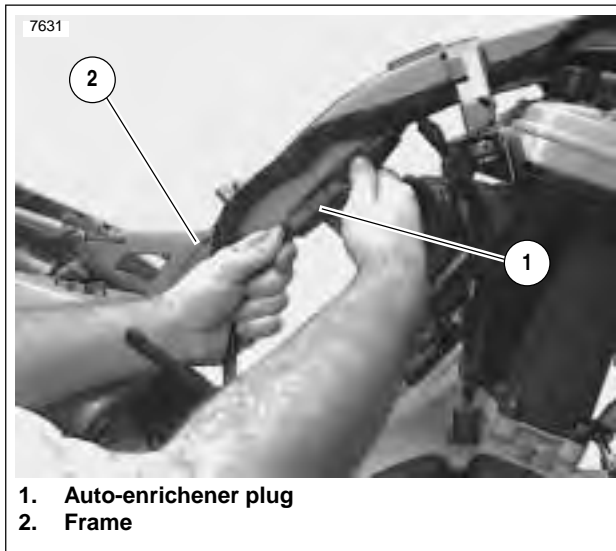


Figure 3-34. Auto-Enrichener Plug

23. See [Figure 3-34](#). Connect auto-enrichener plug.

NOTE

Install entire air cleaner and carburetor as an assembly. See [4.3 AIR CLEANER](#).

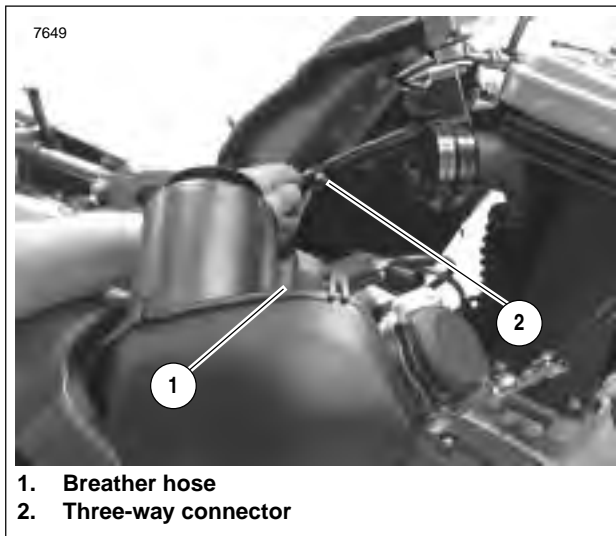


Figure 3-35. Crankcase Breather Hose

24. See [Figure 3-35](#). Connect crankcase breather hose to three-way connector.



Figure 3-36. Hose Clamp

25. See [Figure 3-36](#). Install hose clamp.

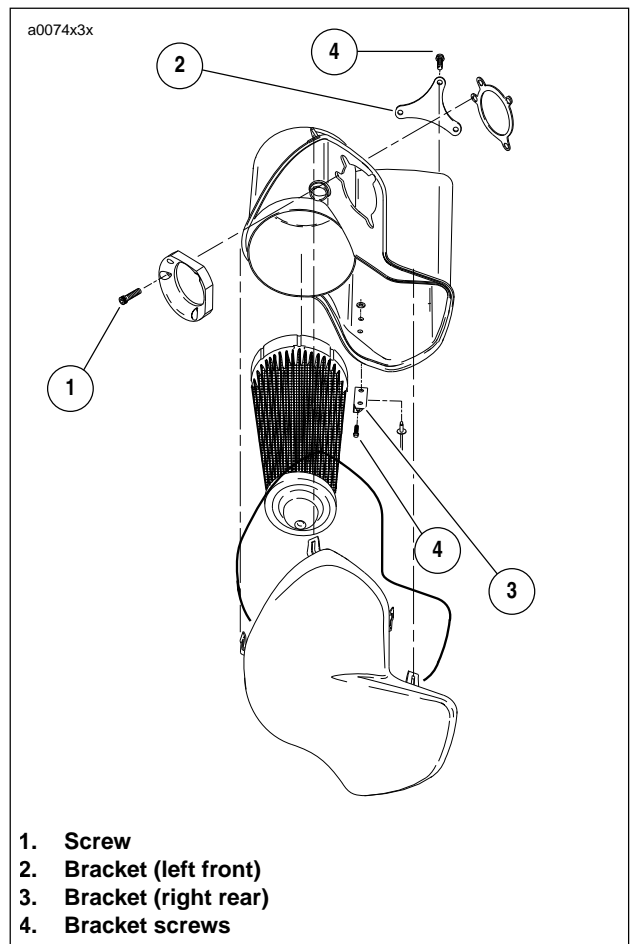


Figure 3-37. Air Cleaner Assembly

26. See [Figure 3-37](#). Install and tighten screws on both air cleaner brackets.
- Right bracket to air cleaner, 36-60 **in-lbs** (4.1-6.8 Nm).
 - Left bracket to crankcases, 120-144 **in-lbs** (13.6-16.3 Nm).
 - Install screw on air cleaner cover.



Figure 3-38. Install Top Rear Tie Bar

27. See [Figure 3-38](#). Install top rear tie bar at frame.
28. Tighten tie bar bolt to 30-33 ft-lbs (41-45 Nm).
29. Install ground strap bolt to engine. Tighten ground strap bolt to 30-33 ft-lbs (41-45 Nm).



Figure 3-39. Install Front Tie Bar

30. See [Figure 3-39](#). Install front tie bar onto engine.
 - a. Apply several drops of LOCTITE 262 (red) to last few threads.
 - b. Tighten to 30-33 ft-lbs (41-45 Nm).



Figure 3-40. Cylinder Head Bolt

31. See [Figure 3-40](#). Install the two mounted cylinder head bolts from the front isolator/engine bracket marked "DO NOT REMOVE".
 - a. Apply several drops of LOCTITE 262 (red) to last few threads of **new** bolts.
 - b. Apply a thin film of clean HD 20W50 engine oil to both sides of **new** thick washers and to bottom of bolt heads. Exercise caution to avoid mixing oil on washers with LOCTITE on bolts.
 - c. Tighten bolts to 60 ft-lbs (81.3 Nm) initially and then loosen each bolt one full turn. Tighten bolts again to 60 ft-lbs (81.3 Nm).

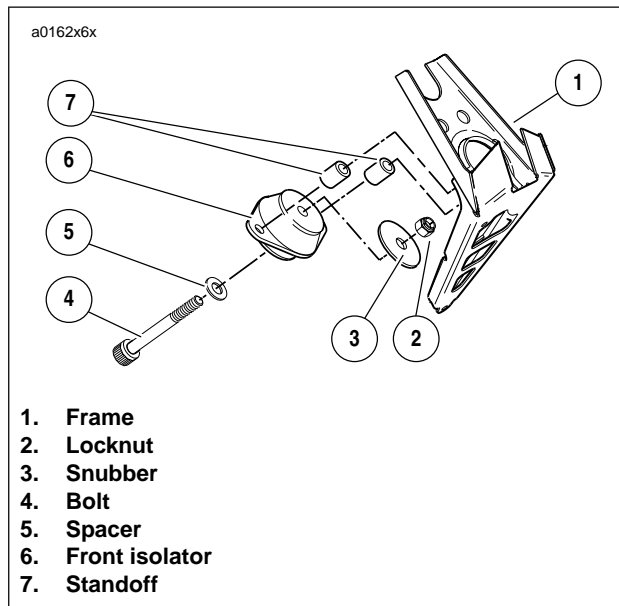


Figure 3-41. Front Isolator Mount

32. See [Figure 3-41](#). Install front isolator mounting bolt, spacer snubber and **new** nut.
33. Tighten front isolator mounting bolt to 63-70 ft-lbs (86-95 Nm).



Figure 3-42. Install Crankcase Breather Hose

34. See [Figure 3-42](#). Install crankcase breather hose and crankcase breather into rocker box grommet.
35. Install horn. See [7.22 HORN](#).
36. Remove jack from under the motor.
37. Install muffler. See [2.20 EXHAUST SYSTEM](#).
38. Install fuel tank. See [4.2 FUEL TANK COVER/FUEL TANK](#).
39. Install **new** oil filter, engine oil and primary chaincase fluid as necessary.

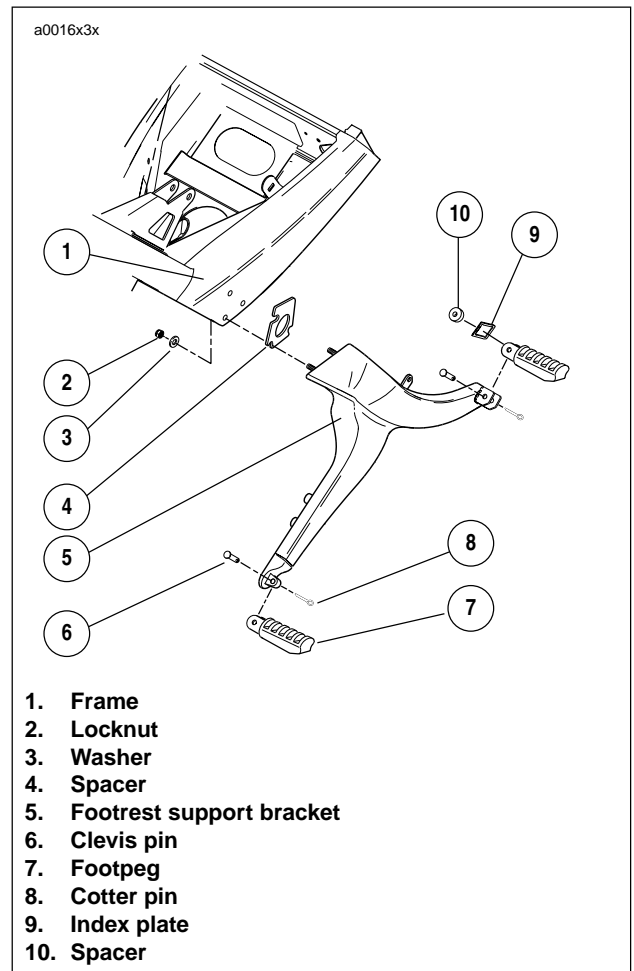


Figure 3-43. Footpeg Bracket Assembly

40. See [Figure 3-43](#). Install right side rider footpeg bracket assembly. See [2.21 FOOTPEGS AND FOOTPEG SUPPORT BRACKETS](#).

⚠ WARNING

Connect positive (+) battery cable first. If positive (+) cable should contact ground with negative (-) cable connected, the resulting sparks can cause a battery explosion, which could result in death or serious injury. (00068a)

41. Connect **both** battery cables, positive cable first. See [7.16 BATTERY](#).

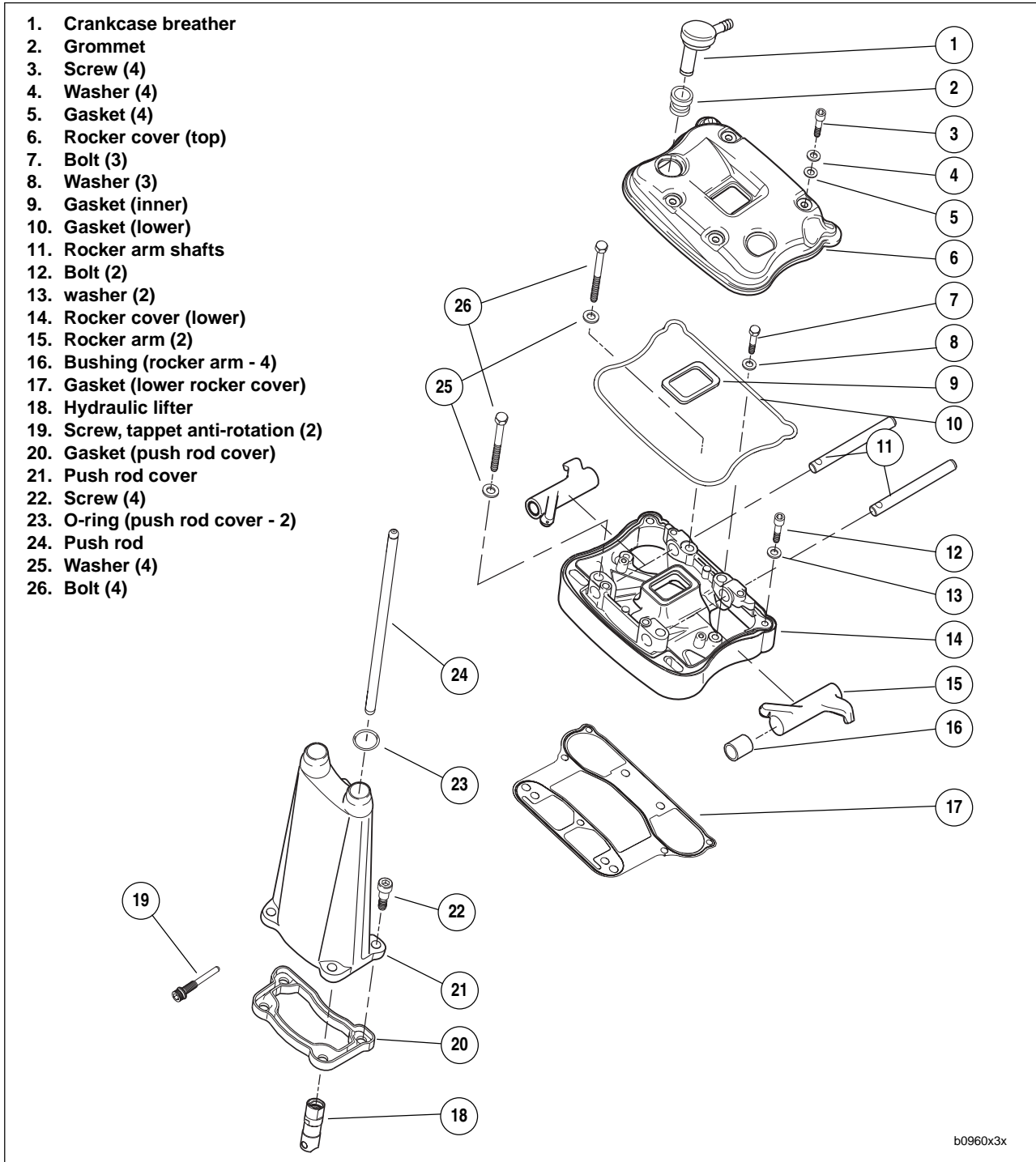
⚠ WARNING

After installing seat, pull upward on front of seat to be sure it is in locked position. While riding, a loose seat can shift causing loss of control, which could result in death or serious injury. (00070a)

42. Install seat. See [2.28 SEAT](#).

REMOVAL

The rocker arm covers and internal components must be removed before removing cylinder heads.



b0960x3x

Figure 3-44. Rocker Arm and Push Rod Cover Assemblies

Rocker Box Assemblies

IMPORTANT NOTE

All washers and fasteners used in the engine are hardened. Do not mix or replace hardened washers and fasteners with unhardened parts. Do not reuse fiber cover seals. Engine damage may result.

1. Remove spark plug.
2. See [Figure 3-44](#). Remove screws with washers and fiber cover seals. Discard fiber seals.
3. Remove top rocker cover.
4. Remove and discard gaskets.
5. Rotate crankshaft until both valves are closed.
6. See [Figure 3-45](#). Remove hardware holding lower rocker cover to cylinder head in the following order.
 - a. Remove two screws and washers (1).
 - b. Remove three bolts and washers (2).
 - c. Loosen the four rocker arm fasteners (3) in 1/4-1/2 turn increments using a cross pattern in order to relieve valve spring pressure on the lower rocker box.
7. See [Figure 3-44](#). Remove lower rocker cover.

NOTE

Remove lower rocker box as an assembly, then disassemble as required.

IMPORTANT NOTE

Mark rocker arm shafts for reassembly in their original positions. Valve train components must be reinstalled in their original positions to prevent accelerated wear and increased valve train noise.

8. See [Figure 3-46](#). Remove rocker arm shafts by tapping them out using a hammer and a soft metal punch.
9. Remove rocker arms, **mark them for reassembly** in their original locations.
10. Mark the location and orientation (top/bottom) of each push rod. Remove push rods.

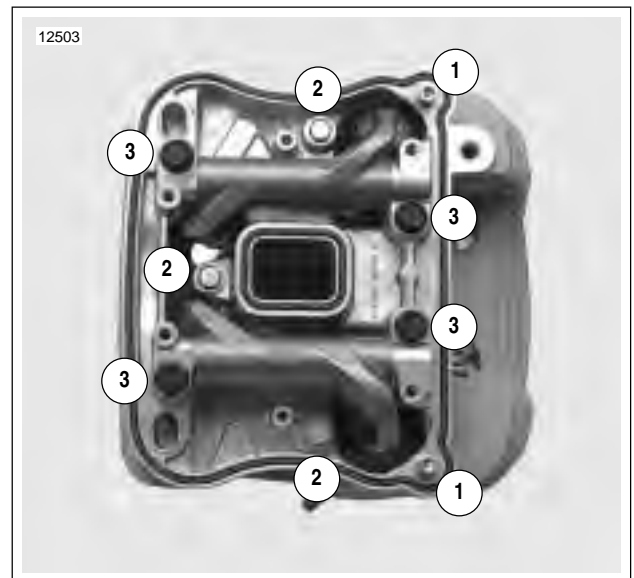


Figure 3-45. Lower Rocker Box Fasteners



Figure 3-46. Removing Rocker Arm Shafts

Cylinder Head Assembly

IMPORTANT NOTE

See [Figure 3-47](#). Distortion to the head, cylinder and crankcase studs may result if head screws are not loosened (or tightened) gradually in the sequence shown.

11. See [Figure 3-47](#). Loosen each head screw 1/8-turn following the sequence shown.
 - a. Continue loosening in 1/8-turn increments until screws are loose. Remove head screws.
 - b. Remove cylinder head, head gasket, and o-rings.
12. Discard head gasket.
13. See [Figure 3-44](#). Remove push rod cover, gasket and valve tappets.

DISASSEMBLY

1. See [Figure 3-48](#). Clamp VALVE SPRING COMPRESSOR TOOL (Part No. HD-34736B) in vise.
2. Compress valve springs with VALVE SPRING COMPRESSOR.
3. See [Figure 3-49](#). Remove valve keepers, upper collar and valve springs. Mark valve keepers for reassembly in their original locations.
4. Use a fine tooth file to remove any burrs on the valve stem at the keeper groove.
5. Mark valve to ensure that it will be reassembled in the same guide. Remove valve, valve stem seal and lower collar assembly.
6. Repeat the above procedure for the other valve.

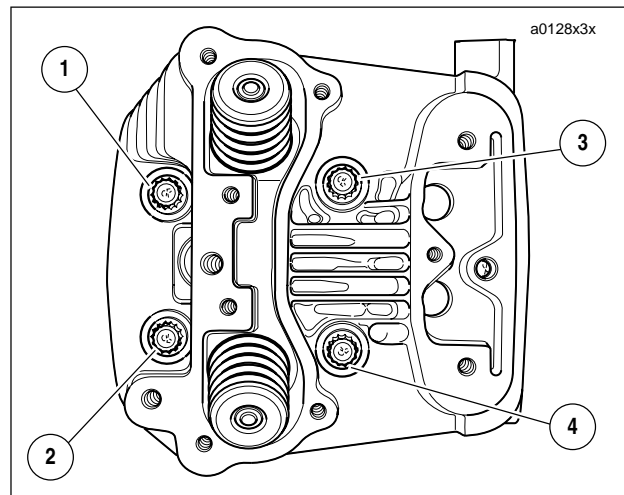
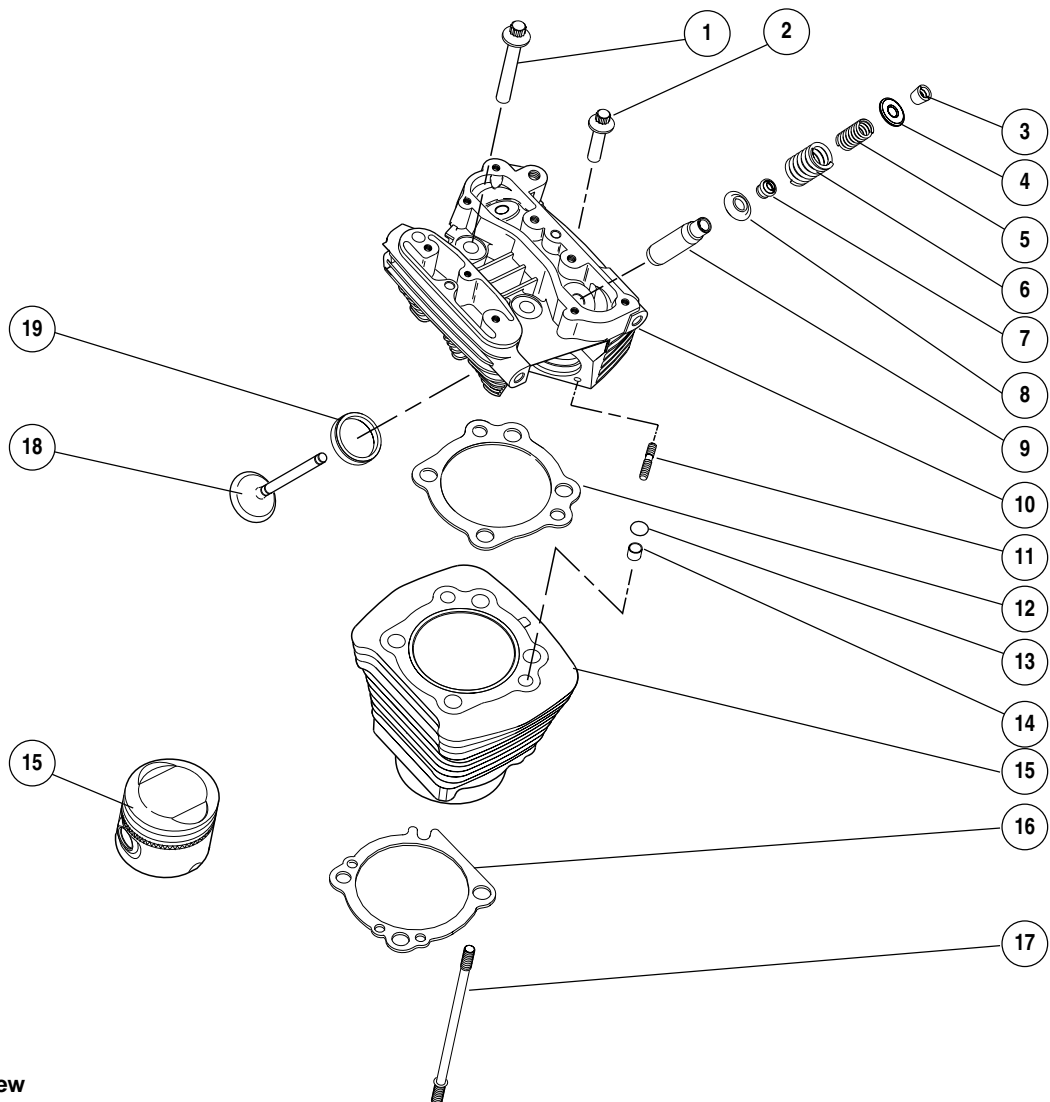


Figure 3-47. Head Screw Loosening/Tightening Sequence



Figure 3-48. Valve Spring Compressor
(Part No. HD-34736B)

a0021x3x



1. Screw
2. Screw
3. Valve collar retainer
4. Upper valve spring collar
5. Inner valve spring
6. Outer valve spring
7. Valve seal
8. Lower valve spring collar
9. Valve guide intake & exhaust (2)
10. Cylinder head
11. Exhaust port stud
12. Cylinder head gasket
13. Cylinder o-ring (4)
14. Cylinder insert
15. Cylinder w/piston & rings
16. Cylinder base gasket
17. Cylinder base stud
18. Exhaust valve
19. Exhaust valve seat

Figure 3-49. Cylinder Head, Cylinder and Piston Assembly

CLEANING AND INSPECTION

Cylinder Head

⚠ WARNING

Compressed air can pierce the skin and flying debris from compressed air could cause serious eye injury. Wear safety glasses when working with compressed air. Never use your hand to check for air leaks or to determine air flow rates. (00061a)

1. Bead blast or scrape carbon from head, top of cylinder and valve ports. Be careful to avoid scratching or nicking cylinder head and cylinder joint faces. Blow off loosened carbon or dirt with compressed air.
2. Soak cylinder head in an aluminum-compatible cleaner/solvent to loosen carbon deposits.
3. Wash all parts in non-flammable solvent, followed by a thorough washing with hot, soapy water. Blow out oil passages in head. Be sure they are free of sludge and carbon particles. Remove loosened carbon from valve head and stem using a wire wheel. Never use a file or other hardened tool which could scratch or nick valve. Polish valve stem with very fine emery cloth or steel wool.

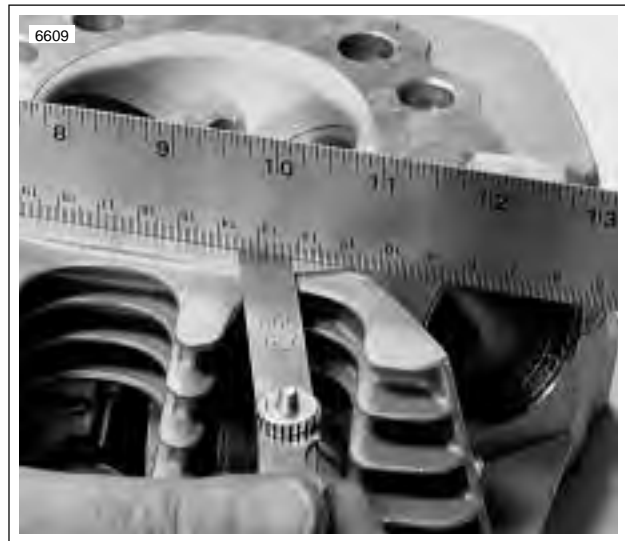


Figure 3-50. Checking Gasket Surface

4. See [Figure 3-50](#). Check head gasket surface on head for flatness. Machine or replace any head which exceeds SERVICE WEAR LIMIT of 0.006 in. (0.152 mm).

Rocker Arm Assemblies

1. Check each rocker arm, at pad end and push rod end, for uneven wear or pitting. Replace rocker arm if either condition exists.



Figure 3-51. Measuring Rocker Arm Shaft Diameter (Rocker Cover Position)



Figure 3-52. Measuring Rocker Arm Shaft Diameter (Rocker Arm Bushing Position)

2. Measure and record rocker arm shaft diameter.
 - a. See [Figure 3-51](#). Measure where shaft fits in lower rocker arm cover.
 - b. See [Figure 3-52](#). Measure where rocker arm bushings ride.



Figure 3-53. Measuring Rocker Arm Shaft Bore Diameter in Lower Rocker Cover



Figure 3-54. Measuring Rocker Arm Bushing Inner Diameter

3. Measure and record rocker arm shaft bore diameter.
 - a. See [Figure 3-53](#). Measure bore of lower rocker cover.
 - b. See [Figure 3-54](#). Measure rocker arm bushing inner diameter.
4. Check the measurements obtained in Steps 2-3 against the SERVICE WEAR LIMITS. Repair or replace parts exceeding limits.
5. Assemble rocker arms and rocker arm shafts into lower rocker cover.
6. Check end play of rocker arm with feeler gauge.
7. Replace rocker arm or lower cover or both if end play exceeds 0.025 in. (0.635 mm).

Valves

1. Replace the valve if there is evidence of burning or cracking.
2. Inspect the end of the valve stem for pitting or uneven wear. Replace the valve if either of these conditions are found.
3. Inspect for burrs around the valve stem keeper groove. Remove burrs with a fine tooth file if found.

Valve Seats

NOTE

Valve seats are also subject to wear. Resurface valve seats whenever valves are refinished.

1. Inspect seats for cracking, chipping or burning. Replace seats if any evidence of these conditions are found.



Figure 3-55. Measuring Valve Stem Protrusion

2. See [Figure 3-55](#). Check seats for recession by measuring valve stem protrusion.
 - a. Wipe valve seats and valve faces clean.
 - b. Measure valve stem protrusion.
 - c. If valve stem protrudes more than 2.031 in. (51.587 mm), replace valve seat or cylinder head.

NOTE

Replacing a valve seat is a complex operation requiring special equipment. If the seat is loose or is not fully seated in the head, then seat movement will prevent the proper transfer of heat from the valve. The seat surface must be flush with (or below) the head surface. See [3.1 SPECIFICATIONS](#) for valve seat-to-cylinder head fit.

Valve Guides

1. Clean valve guides by lightly honing with VALVE GUIDE HONE (Part No. HD-34723).
2. Scrub guides with VALVE GUIDE BRUSH (Part No. HD-34751) and hot soapy water. Measure valve stem outer diameter and valve guide inner diameter. Check measurements against [3.1 SPECIFICATIONS](#).

Valve Springs

1. Inspect valve springs for broken or discolored coils.

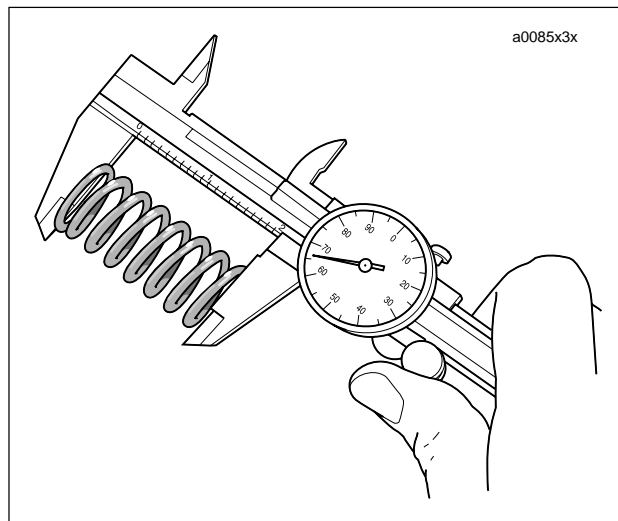


Figure 3-56. Checking Spring Free Length

2. See [Figure 3-56](#). Check free length and compression force of each spring. Compare with [3.1 SPECIFICATIONS](#). If spring length is shorter than specification or if spring compression force is below specification, replace spring.

Spark Plug Threads

Inspect spark plug threads for damage. If threads in head are damaged, a special plug type insert can be installed using a 12 mm spark plug repair kit.

Push Rods

Examine push rods, particularly the ball ends. Replace any rods that are bent, worn, discolored or broken.

Replacing Rocker Arm Bushings

1. See [Figure 3-57](#). To replace worn bushings, press or drive them from the rocker arm. If bushing is difficult to remove, turn a 9/16-18 tap into bushing. From opposite side of rocker arm, press out bushing and tap using a discarded rocker arm shaft.
2. Press replacement bushing into rocker arm, flush with arm end, and split portion of bushing towards top of arm.
3. Using remaining old bushing as a pilot, line ream new bushing with **ROCKER ARM BUSHING REAMER** (Part No. HD-94804-57).
4. Repeat for other end of rocker arm.

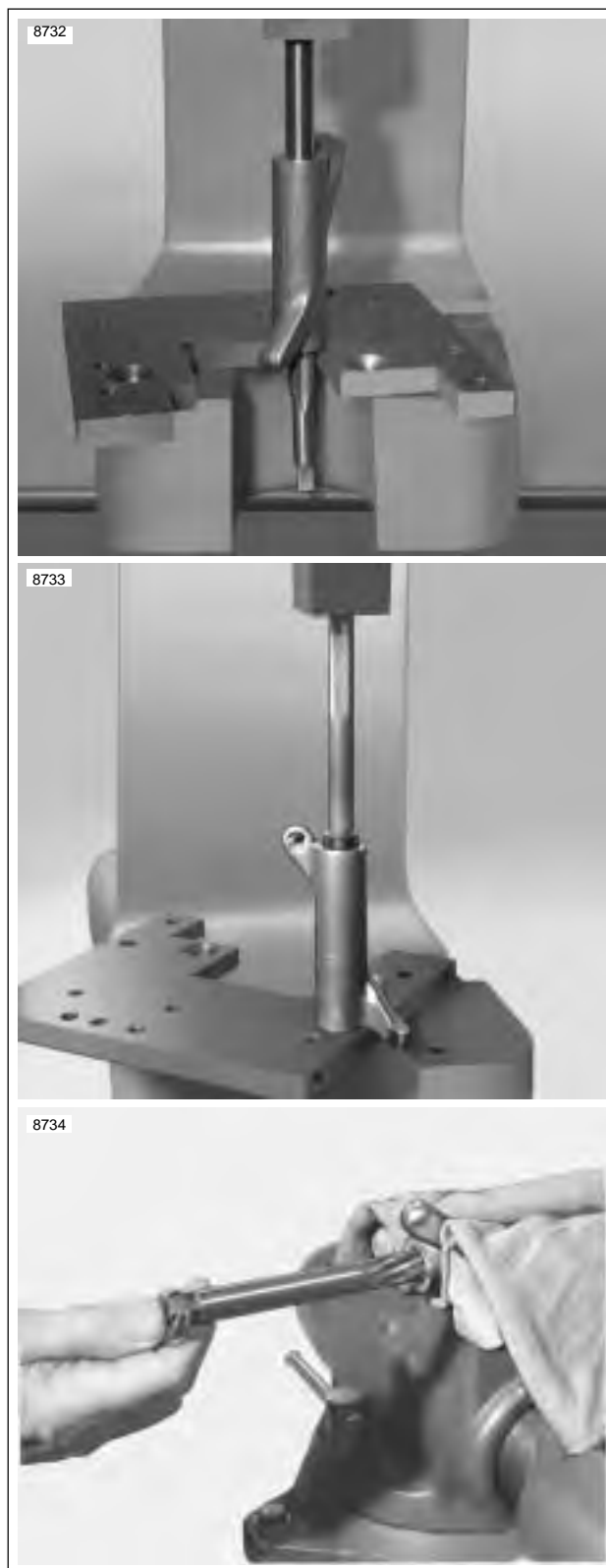


Figure 3-57. Replacing Rocker Arm Bushings

Replacing Valve Guides

Valve guide replacement, if necessary, must be done before valve seat is ground. It is the valve stem hole in valve guide that determines seat grinding location. Valve stem-to-valve guide clearances are listed in [Table 3-21](#). If valve stems and/or guides are worn beyond limits, install **new** parts.

Table 3-21. Valve Stem Clearances and Service Wear Limits

VALVE	CLEARANCE	SERVICE WEAR LIMIT
Exhaust	0.0015-0.0033 in. (0.0381-0.0838 mm)	0.0040 in. (0.1016 mm)
Intake	0.0008-0.026 in. (0.025-0.076 mm)	0.0035 in. (0.0889 mm)

1. To remove shoulderless guides, press or tap guides toward combustion chamber using VALVE GUIDE REMOVER/INSTALLER (Part No. HD-34740).
2. Clean and measure valve guide bore in head.
3. Measure outer diameter of a **new** standard valve guide. The guide diameter should be 0.0020-0.0033 in. (0.0508-0.0838 mm). larger than bore in head. If it is not, select one of the following oversizes: +0.001 in. (+0.025 mm), +0.002 in. (+0.051 mm) or +0.003 in. (+0.076 mm) (intake and exhaust).

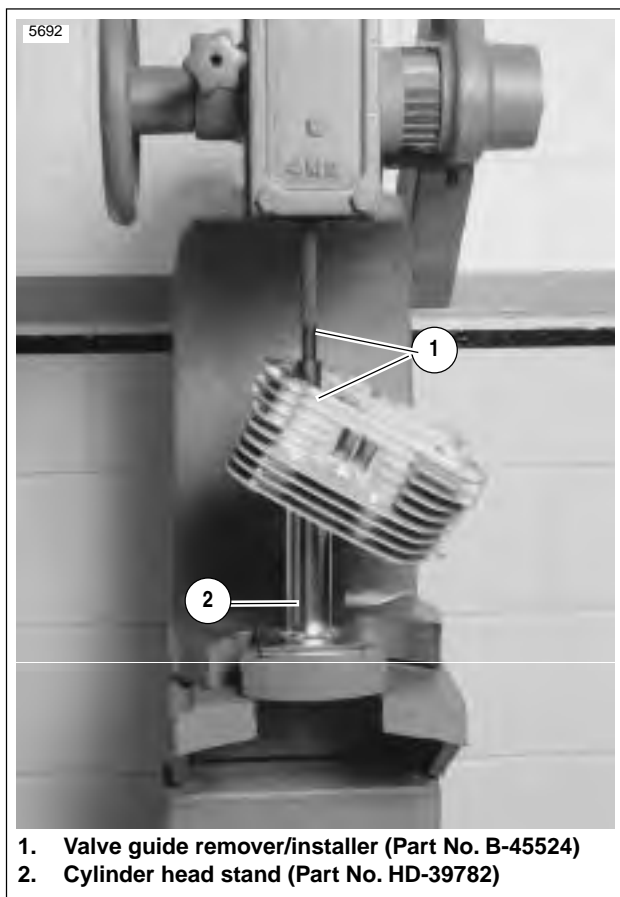


Figure 3-58. Installing Shoulderless Valve Guide

4. See [Figure 3-58](#). Install shoulderless guides using VALVE GUIDE INSTALLATION TOOL (Part No. HD-34731) and DRIVER HANDLE (Part No. HD-34740). Press or drive guide until the tool touches the machined surface surrounding the guide. At this point, the correct guide height has been reached.
5. Ream guides to final size or within 0.0010 in. (0.0254 mm) of final size using VALVE GUIDE REAMER (Steel, Part No. HD-39932 or Carbide, Part No. HD-39932-CAR). Use REAMER LUBRICANT (Part No. HD-39964) or liberal amounts of suitable cutting oil to prevent reamer chatter.

NOTE

The hone is not intended to remove material.

6. Apply the proper surface finish to the valve guide bores using the VALVE GUIDE HONE (Part No. HD-34723). Lubricate hone with honing oil. Driving hone with an electric drill, work for a crosshatch pattern with an angle of approximately 60°.

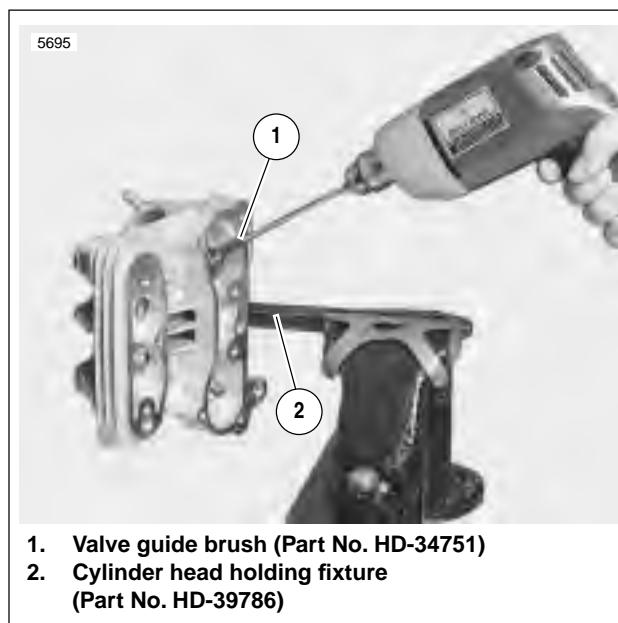


Figure 3-59. Cleaning Valve Guides

7. See [Figure 3-59](#). Thoroughly clean valve guide bores using VALVE GUIDE BRUSH (Part No. HD-34751) and hot soapy water.

PROCEDURE FOR USING THE NEWAY VALVE SEAT CUTTER

Table 3-22. Neway Valve Seat Cutter

PART NO.	SPECIALTY TOOL
HD-35758A	Neway valve seat cutter
HD-39786	Cylinder head holding fixture

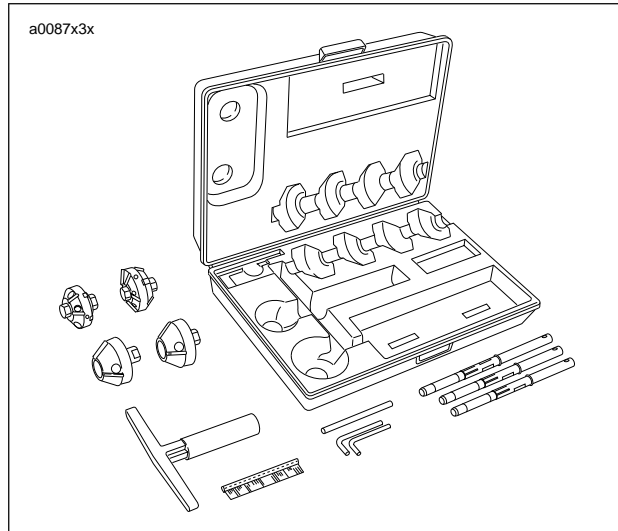


Figure 3-60. Neway Valve Seat Cutter

NOTES

- Verify correct valve stem to valve guide clearance before refacing. See [Table 3-21](#). If **new** guides must be installed, complete that task before refacing valves and seats.
 - This procedure is not based on the lapping of valves. The end result is an interference fit between the valve of 45° and the valve seat which will be 46°.
1. Secure cylinder head for service.
 - a. Thread 12 mm end of CYLINDER HEAD HOLDING FIXTURE (Part No. HD-39786) into cylinder head spark plug hole.
 - b. Clamp tool in vise and further tighten cylinder head onto the fixture to prevent any movement during operation.
 - c. Place cylinder head at a 45° angle or one that offers a comfortable working position.

2. Obtain the NEWAY VALVE SEAT CUTTER SET (HD-35758A) and cut valve seat angle to 46°. Do not remove any more metal than is necessary to clean up the seat (that is, to provide a uniform finish and remove pitting).
3. In order to determine the correct location of the 46° valve seat in the head, measure the width of the valve to be used and subtract 0.080" (2.032 mm) from that number.
4. Set your dial caliper to the lesser measurement and lock down for quick reference. This is the location of your valve seat.
5. Use a permanent magic marker to highlight the valve seat area that is going to be cut and be sure to highlight all 3 angles. Allow marker to dry before proceeding.

NOTES

- Always ensure cutter blades and cutter pilot are clean before beginning the cutting process. The correct cleaning brush is supplied with the Neway tool set.
 - Also ensure the inside of the valve guide is clean by using Kent-Moore cleaning brush (Part No. HD-34751).
6. Choose the cutter pilot that fits properly into the valve guide hole and securely seat the pilot by pushing down and turning using the installation tool supplied in the tool set.
 7. Choose the proper 46° cutter (intake or exhaust) and gently slide the cutter onto the pilot being careful not to drop the cutter onto the seat.
 8. While applying a constant and consistent pressure, remove just enough material to show a complete clean-up on the 46° angle.

NOTES

- If the width of the clean-up angle is greater on one side of the seat than the other, the guide may need to be replaced due to improper installation.
- After making the 46° cut, if you discover a groove cut completely around the seat this means the blades of the cutter are in alignment and need to be staggered. This is accomplished by loosening all of the blades from the cutter body and moving each blade slightly in it's cradle in opposite directions on the cutter. The tool needed to loosen the blades is supplied in the tool set. A permanent magic marker mark every 90° will help in determining where new angles are.

9. Next, with your dial caliper locked to the predetermined setting, measure the 46° cut at the outer most edge at the widest point of the circle to determine what cut needs to be made next.
 - a. If the 46° cut is too high (towards the combustion chamber), use the 31° cutter to lower the valve seat closer to the port.
 - b. If the 46° cut is too low, use the 60° cutter to raise the valve seat or move it away from the port.

NOTE

- *Due to using the top measurement of our valve seat as a reference point it will usually be necessary to use the 31° cutter following the initial 46° cut.*
 - *Always highlight the valve seat with the permanent magic marker in order to ensure the location of the 46° valve seat.*
10. If the location of the valve seat is not correct, repeat steps 8 and 9.
 11. When you accomplish a complete clean-up of the 46° angle and the width is at least .062 in. (1.575 mm), proceed to the next step.

12. Select the proper 60° cutter and gently slide the cutter pilot to the valve seat.
13. Remove just enough material to provide an even valve seat width of .040-.062 in. (1.016-1.575 mm).
14. Remove cutter pilot and wash head thoroughly and dry completely.
15. Repeat the process on any valve seat that needs service.
16. Insert valve to be used in the valve guide and bottom on the valve seat. Positioning the cylinder head port upwards and with slight thumb pressure against the valve, completely fill the port with solvent to verify proper seal between the valve and the valve seat.

NOTE

Hold pressure against the valve for a minimum of 10 seconds. If any leakage occurs, examine the valve seat for irregularities or defects and if necessary repeat the above cutting process.

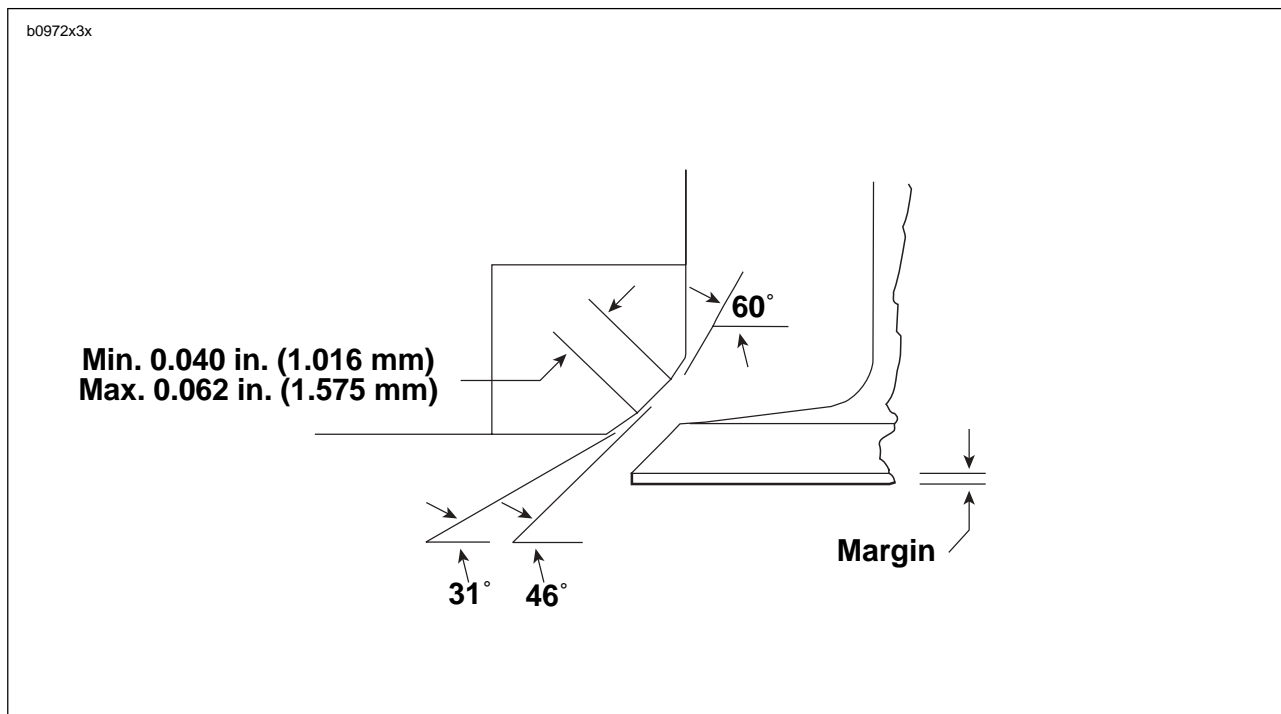


Figure 3-61. Intake and Exhaust Valve and Seat Dimensions

ASSEMBLY

1. Wash cylinder head and valves in warm, soapy water to remove all debris.
2. Scrub valve guide bores with VALVE GUIDE BRUSH (Part No. HD-34751) and hot, soapy water.

⚠ WARNING

Compressed air can pierce the skin and flying debris from compressed air could cause serious eye injury. Wear safety glasses when working with compressed air. Never use your hand to check for air leaks or to determine air flow rates. (00061a)

3. Blow dry with compressed air.
4. Apply a liberal amount of engine oil to the valve stem.
5. Insert valve into valve guide and install lower collar.

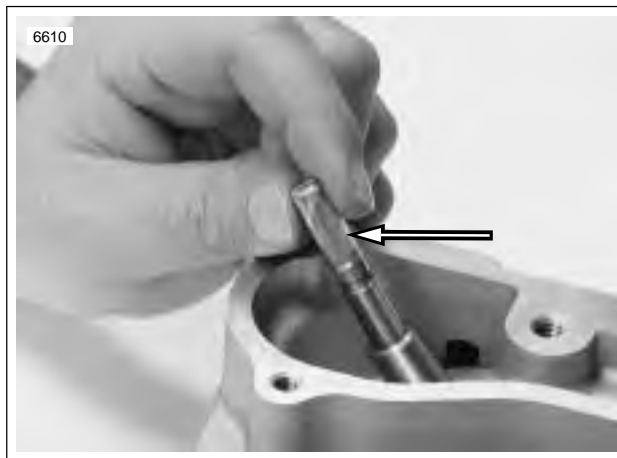
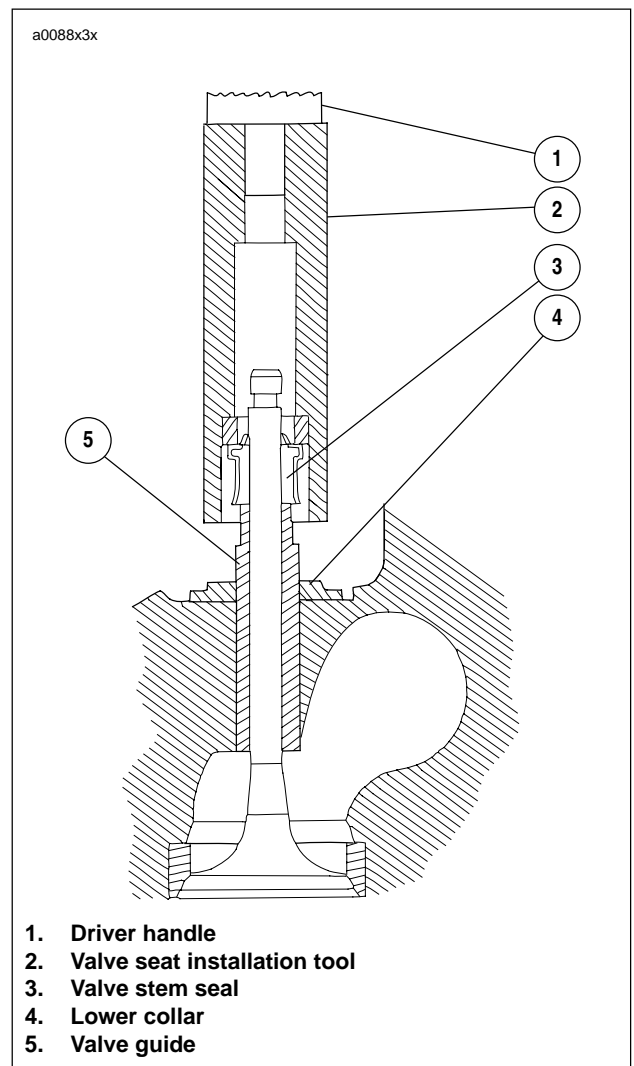


Figure 3-62. Valve Guide Seal Protector Sleeve

6. See [Figure 3-62](#). Place a protective sleeve over the valve stem keeper groove. Coat the sleeve with oil and place a new seal over the valve stem.

IMPORTANT NOTES

- **Always use a protective sleeve on the valve stem keeper groove when installing valve stem seal. If the seal is installed without using the protective sleeve, the seal will be damaged.**
- **Do not remove valve after seal is installed. Otherwise, sharp edges on keeper groove will damage seal.**



1. Driver handle
2. Valve seat installation tool
3. Valve stem seal
4. Lower collar
5. Valve guide

Figure 3-63. Valve Seal Installation

7. See [Figure 3-63](#). Tap the valve stem seal onto the valve guide using the VALVE SEAL INSTALLATION TOOL (Part No. HD-34643A) and DRIVER HANDLE (Part No. HD-34740). The seal is completely installed when the tool touches the lower collar.
8. See [Figure 3-49](#). Install valve springs and upper collar.
9. Compress springs with VALVE SPRING COMPRESSOR (Part No. HD-34736B).
10. Insert valve keepers into upper collar, making sure they engage groove in valve stem. The keeper gaps should be equal.
11. Release and remove VALVE SPRING COMPRESSOR.
12. Repeat Steps 4-11 for the remaining valve.

PUSH ROD COVER INSTALLATION

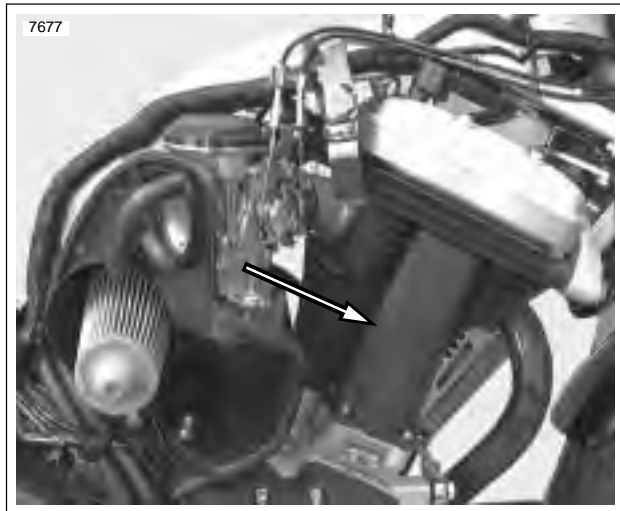


Figure 3-64. Push Rod Location

NOTE

Push rod cover must be installed prior to installing cylinder head.

1. See Figure 3-64. Install push rod cover.
 - a. Install **new** o-rings (2) on top of each push rod cover (3).
 - b. Install **new** push rod cover gasket (5) onto bottom of each push rod cover.
 - c. Install push rod cover assembly and start the four fasteners (4) securing bottom of cover to crankcase.
 - d. Tighten fasteners to 30-40 **in lbs** (3.4-4.5 Nm).
2. Refer to Table 3-23. Identify push rod color coding, length and respective push rod positions in engine. Place intake and exhaust push rods onto seat at top of tappet.

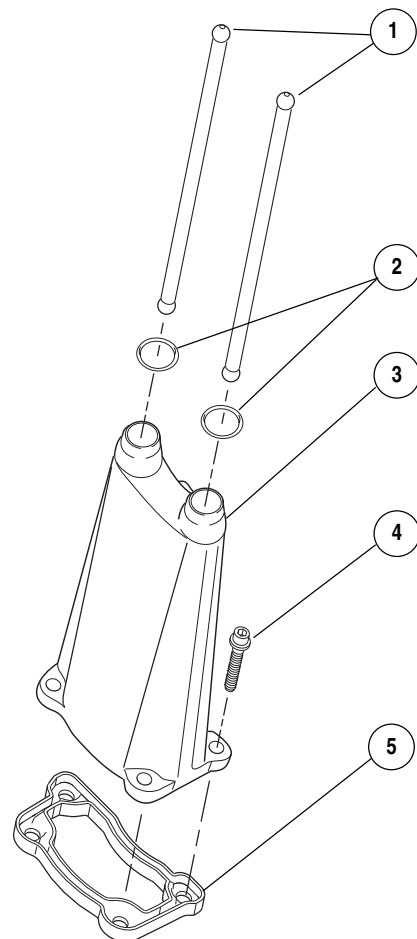
Table 3-23. Push Rod Selection

POSITION	COLOR CODES	LENGTH	PART NO.
Exhaust	1 Band-Black	10.969 in. (278.613 mm)	17985-00Y
Intake	1 Band-Green	10.915 in. (277.241 mm)	17984-00YA

IMPORTANT NOTE

After head has been installed do not turn engine over until both push rods can be turned with fingers. Otherwise, damage to push rods or rocker arms may result.

b1092x3x



1. Push rod (2)
2. O-ring (2)
3. Push rod cover
4. Screws (4)
5. Push rod cover gasket

Figure 3-65. Push Rods and Push Rod Cover Assembly

CYLINDER HEAD INSTALLATION

NOTE

- Thoroughly clean and lubricate the threads of the cylinder head screws before installation. Friction caused by dirt and grime will result in a false torque indication.
 - Pushrod cover must be installed prior to installing cylinder head.
1. Thoroughly clean and dry the gasket surfaces of cylinder and cylinder head.
 2. Install **new** o-rings over two ring dowels at the top of the cylinder. Apply a very thin film of clean H-D 20W50 engine oil to o-rings before installation.

NOTE

To ensure proper head gasket alignment, install new o-rings over cylinder ring dowels before installing the head gasket. Improper head gasket alignment will cause leaks.

3. Install a **new** head gasket to cylinder.
4. Carefully lower cylinder head over studs and position on dowels. Use great care so as not to disturb head gasket.
5. Lightly coat the threads and bottom face of the cylinder head bolts in clean H-D 20W50 engine oil. Wipe off any excess oil.

NOTE

The procedure for tightening the head screws is critical to proper distribution of pressure over gasket area. It prevents gasket leaks, stud failure, and head and cylinder distortion.

6. Start the cylinder head screws onto the cylinder studs, two short bolts on the left side of the engine, two long bolts on the right.
7. See [Figure 3-66](#). Always start with screw numbered one, as shown. In increasing numerical sequence (i.e. – 1, 2, 3 and 4):
 - a. Tighten bolts to 96-120 **in-lbs** (11-14 Nm).
 - b. Tighten bolts to 13-15 ft-lbs (18-20 Nm).
 - c. Loosen all screws.
8. After screws are loosened from initial torque, tighten head screws in three stages. Tighten fasteners in increasing numerical sequence (i.e. – 1, 2, 3 and 4).
 - a. Tighten each screw to 96-120 **in-lbs** (11-14 Nm).
 - b. Tighten each screw to 13-15 ft-lbs (18-20 Nm).
 - c. See [Figure 3-67](#). Mark cylinder head and head screw shoulder with a line as shown (View A).
 - d. Turn all bolts an additional 85° -95° .

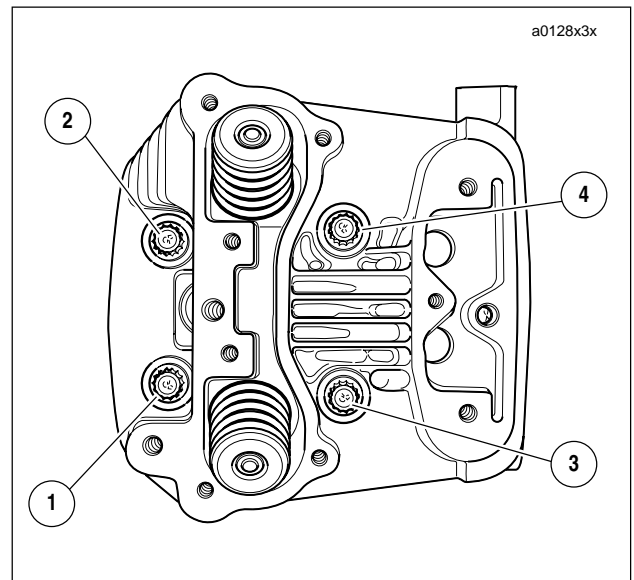


Figure 3-66. Head Screw Loosening/Tightening Sequence

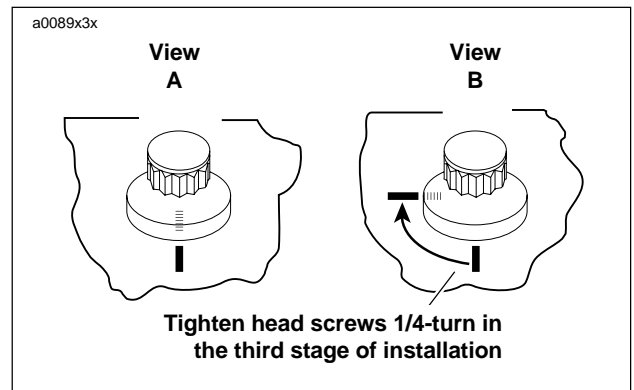
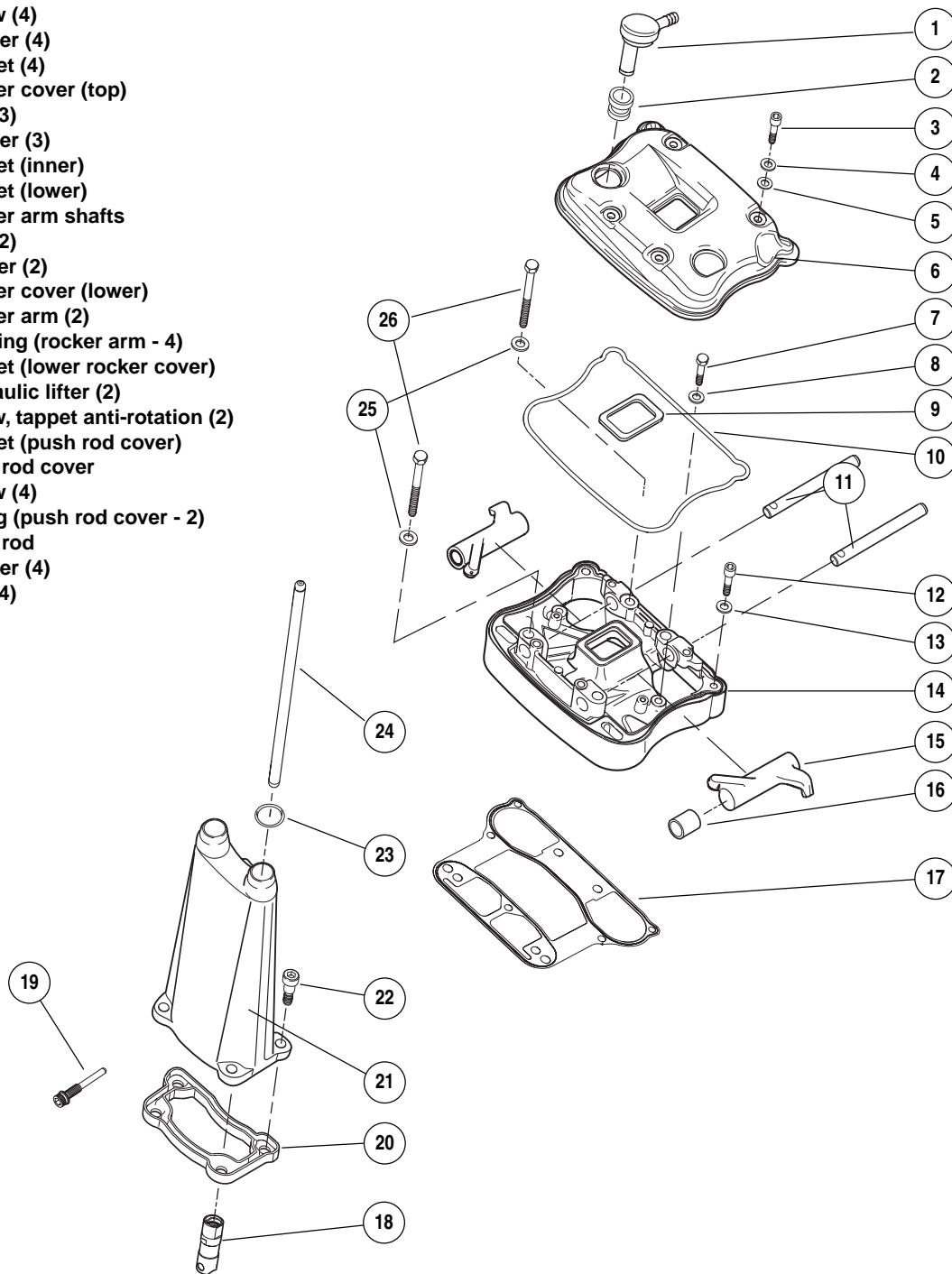


Figure 3-67. Tightening Head Screws

1. Crankcase breather
2. Grommet
3. Screw (4)
4. Washer (4)
5. Gasket (4)
6. Rocker cover (top)
7. Bolt (3)
8. Washer (3)
9. Gasket (inner)
10. Gasket (lower)
11. Rocker arm shafts
12. Bolt (2)
13. washer (2)
14. Rocker cover (lower)
15. Rocker arm (2)
16. Bushing (rocker arm - 4)
17. Gasket (lower rocker cover)
18. Hydraulic lifter (2)
19. Screw, tappet anti-rotation (2)
20. Gasket (push rod cover)
21. Push rod cover
22. Screw (4)
23. O-ring (push rod cover - 2)
24. Push rod
25. Washer (4)
26. Bolt (4)



b0960x3x

Figure 3-68. Rocker Arm and Push Rod Cover Assemblies

9. See [Figure 3-68](#). Install **new** gasket. Place lower rocker box assembly, with rocker arms and shafts, into position. Place push rods in rocker arm sockets.

IMPORTANT NOTE

Do not stretch gaskets while installing. Use the top rocker cover to press the gasket into position.

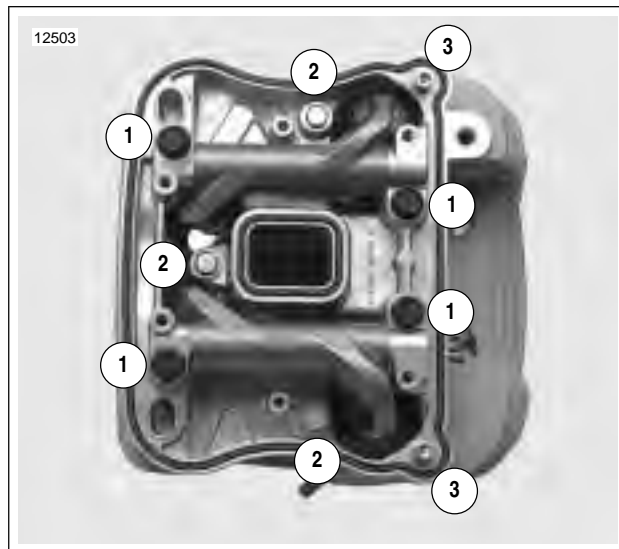


Figure 3-69. Lower Rocker Box Fasteners

10. See [Figure 3-69](#). Install hardware attaching lower rocker cover to cylinder head in the following order. After loosely installing all fasteners, use a cross pattern on the four large bolts that fasten the lower rocker box to head to tighten and then torque to specifications. This will bleed the tappets. Finish tightening remaining fasteners. Fastener sequences, sizes and torque specifications are listed in [Table 3-24](#).
- Tighten bolts (1) to 18-22 ft-lbs (24-30 Nm).
 - Tighten bolts (2) to 135-155 **in-lbs** (15-18 Nm).
 - Tighten bolts (3) to 135-155 **in-lbs** (15-18 Nm).

11. See [Figure 3-68](#). Install upper rocker covers.
- Place a **new** inner gasket on lower rocker box assembly.
 - Place a **new** lower gasket on lower rocker cover.
 - Install upper rocker cover using screws with washers and **new** fiber seals. Tighten screws to 120-168 **in-lbs** (13.6-18.9 Nm).

Table 3-24. Lower Rocker Box Hardware

ITEM	SIZE	TORQUE
(1) Bolt w/washer	5/16-18 X 2-1/2	18-22 ft-lbs (24-30 Nm)
(2) Bolt w/washer	1/4-20 X 1-1/4	135-155 in-lbs (15-18 Nm)
(3) Screw w/washer	1/4-20 X 1-1/2	135-155 in-lbs (15-18 Nm)

REMOVAL/DISASSEMBLY

1. Strip motorcycle as described under this procedure. See [3.3 STRIPPING MOTORCYCLE FOR ENGINE SERVICE](#).
2. Remove cylinder head. See [3.5 CYLINDER HEAD](#).
3. Clean crankcase around cylinder base to prevent dirt and debris from entering crankcase while removing cylinder.
4. See [Figure 3-70](#). Turn engine over until piston of cylinder being removed is at bottom of its stroke.
5. Carefully raise cylinder just enough to permit placing clean towel under piston to prevent any foreign matter from falling into crankcase.

NOTE

If cylinder does not come loose, lightly tap a plastic hammer perpendicular to the cylinder fins. Never try to pry a cylinder up.

6. Carefully lift cylinder over piston and cylinder studs. Do not allow piston to fall against cylinder studs. Discard cylinder base gasket.

IMPORTANT NOTE

With cylinder removed, be careful not to bend the cylinder studs. The slightest bend could cause a stress riser and lead to stud failure.

7. Install a 6.0 in. (152 mm) length of 1/2 in. (12.7 mm) ID plastic or rubber hose over each cylinder stud. This will protect the studs and the piston.

WARNING

Wear safety glasses or goggles when removing or installing piston pin retaining rings. Piston pin retaining rings are compressed in the ring groove and can fly out when removed from the groove, which could result in serious eye injury. (00293a)

IMPORTANT NOTE

DO NOT re-use piston pin retaining rings. Removal may weaken retaining rings and they may break or dislodge if reinstalled resulting in engine damage.

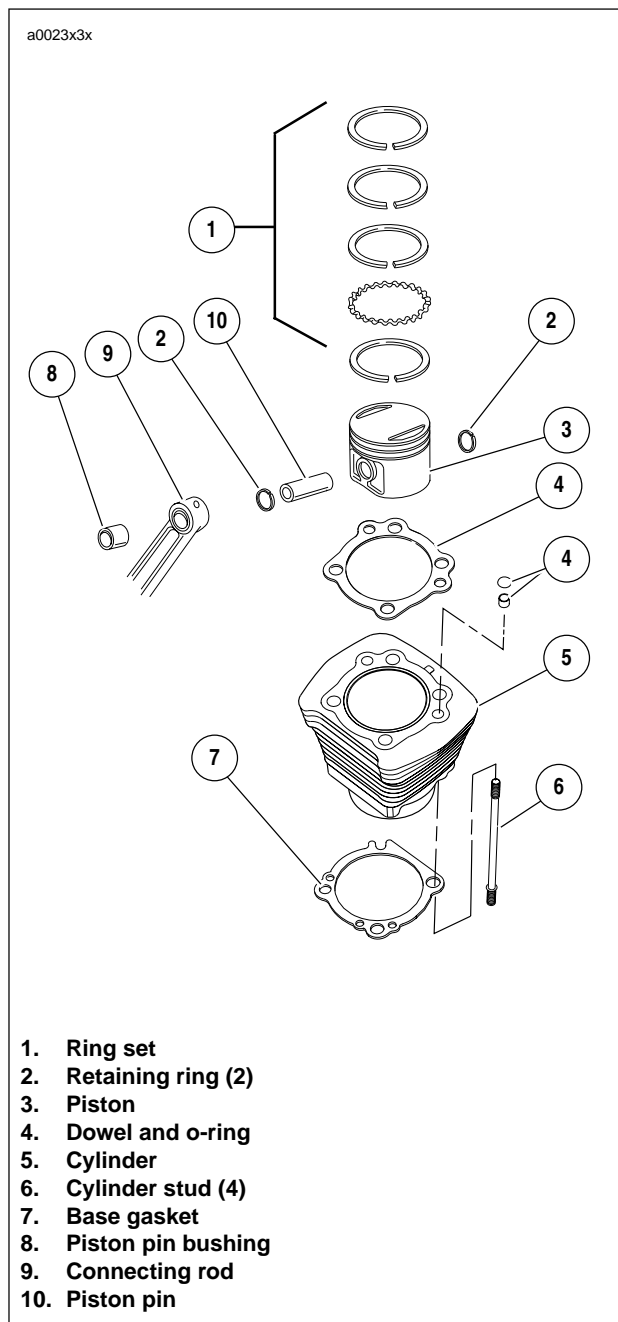


Figure 3-70. Cylinder and Piston

NOTE

Since the piston pin is a loose fit in the piston, the pin will easily slide out. The pin has tapered ends to help seat the round retaining rings.

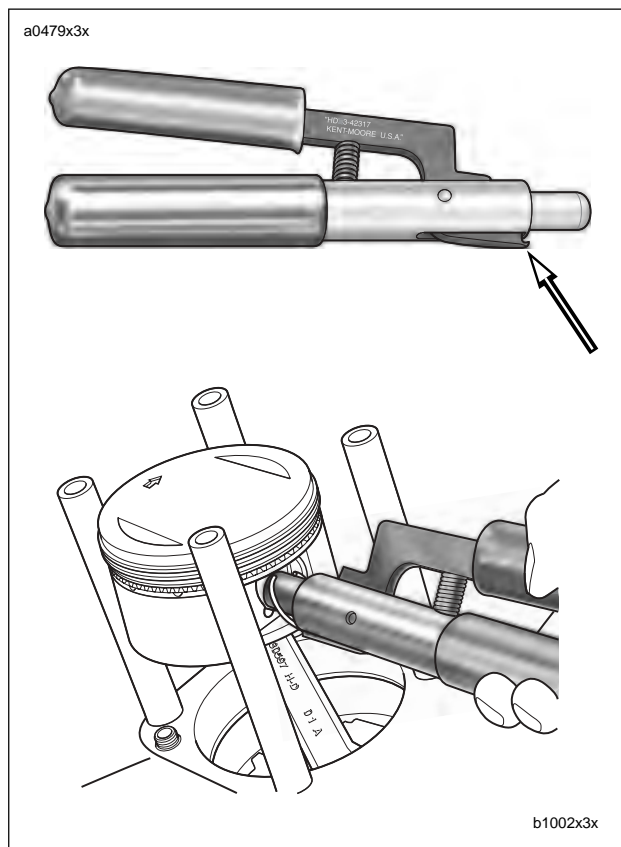


Figure 3-71. Removing Piston Pin Circlip Using Piston Pin Circlip Remover/Installer (Part No. HD-42317)

8. Remove the piston pin circlip as follows:
 - a. See [Figure 3-71](#). Insert the PISTON PIN CIRCLIP REMOVER/INSTALLER (HD-42317) into the piston pin bore until claw on tool is positioned in slot of piston (directly under circlip).
 - b. Squeeze the handles of the tool together and pull from bore. In the event that the circlip should fly out, hold a shop towel over the bore during removal. Remove circlip from claw and discard.

NOTE

It is not necessary to remove both piston pin circlips during piston removal. Leave the second circlip in the pin bore.

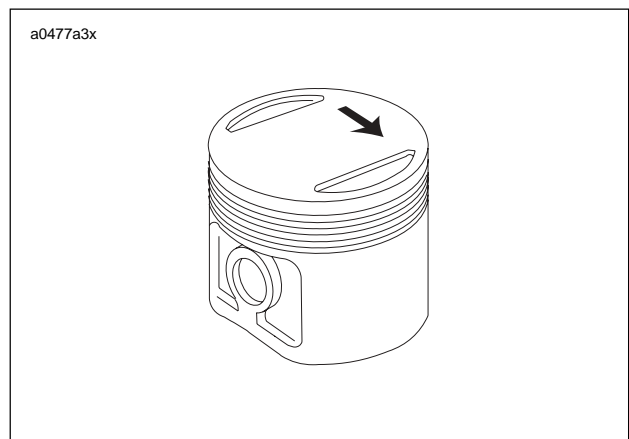


Figure 3-72. Piston Identification and Direction

9. See [Figure 3-72](#). The arrow at the top of pistons must always point toward the front of the engine.

NOTE

Handle the piston with extreme care. The alloy used in these pistons is very hard. Any scratches, gouges or other marks in the piston could score the cylinder during engine operation and cause engine damage.

10. Spread piston rings outward until they clear grooves in piston and lift off.

CLEANING AND INSPECTION

⚠ WARNING

Compressed air can pierce the skin and flying debris from compressed air could cause serious eye injury. Wear safety glasses when working with compressed air. Never use your hand to check for air leaks or to determine air flow rates. (00061a)

1. Soak cylinder and piston in an aluminum-compatible cleaner/solvent until deposits are soft, then clean with a brush. Blow off loosened carbon and dirt particles and wash in solvent.
2. Clean oil passage in cylinder with compressed air.
3. Clean piston ring grooves with a piece of compression ring ground to a chisel shape.
4. Examine piston pin to see that it is not pitted or scored.
5. Check piston pin bushing to see that it is not loose in connecting rod, grooved, pitted or scored.
 - a. A piston pin properly fitted to upper connecting rod bushing has a 0.00125 to 0.00175 in. (0.03175-0.04445 mm) clearance in bushing.
 - b. See Connecting Rod Bushing section. If piston pin-to-bushing clearance exceeds 0.00200 in. (0.05080 mm), replace worn parts.
6. Clean piston pin retaining ring grooves.
7. Examine piston and cylinder for cracks, burnt spots, grooves and gouges.
8. Check connecting rod for up and down play in lower bearings. When up and down play is detected, lower bearing should be refitted. This requires removing and disassembling engine crankcase.

Checking Gasket Surface

IMPORTANT NOTE

If cylinder gasket surface does not meet flatness specifications, replace cylinder and piston. Proper tolerances will extend component life and prevent leaks.

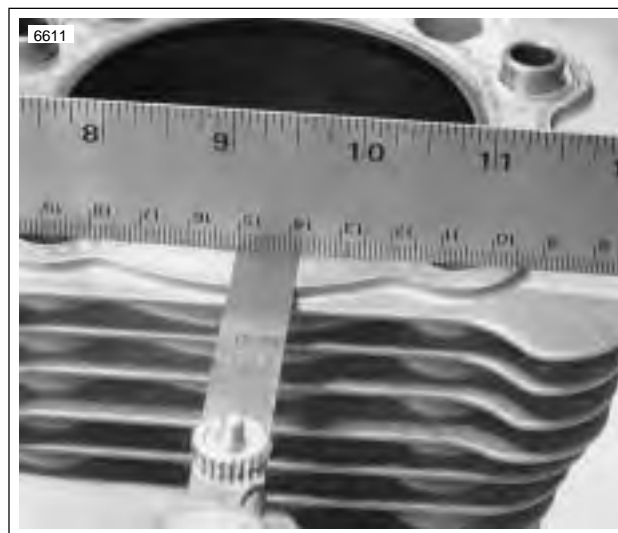


Figure 3-73. Checking Gasket Surfaces

1. See [Figure 3-73](#). Check cylinder head gasket surface for flatness.
 - a. Lay a straightedge across the surface.
 - b. Try to insert a feeler gauge between the straightedge and the gasket surface.
 - c. If cylinder head gasket surface is not flat within 0.006 in. (0.152 mm), replace cylinder and piston.
2. Check cylinder base gasket surface for flatness.
 - a. Lay a straightedge across the surface.
 - b. Try to insert a feeler gauge between the straightedge and the gasket surface.
 - c. If cylinder base gasket surface is not flat within 0.008 in. (0.203 mm), replace cylinder and piston.

Measuring Cylinder Bore

1. Remove any burrs from the cylinder gasket surfaces.
2. See [Figure 3-74](#). Install a head gasket, base gasket and o-rings, and CYLINDER TORQUEPLATES (Part No. HD-33446A) and XL EVOLUTION TORQUE PLATE BOLTS (Part No. HD-33446-86). Tighten the bolts using the same method used when installing the cylinder head screws. See [3.5 CYLINDER HEAD](#).

NOTE

Torque plates, properly tightened and installed with gaskets, simulate engine operating conditions. Measurements will vary as much as 0.001 in. (0.025 mm) without torque plates.

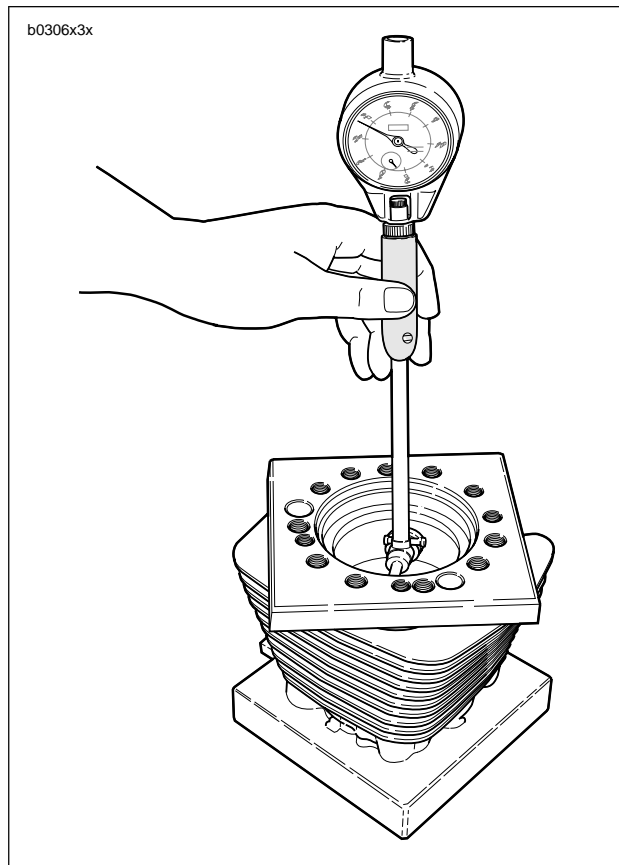


Figure 3-74. Measuring Cylinder Bore Using Torque Plates (Part No. HD-33446A)

3. See [Figure 3-74](#). Take cylinder bore measurement in ring path, starting about 0.50 in. (12.7 mm) from top of cylinder, measuring from front to rear and then side to side. Record readings.
4. Repeat measurement at center and then at bottom of ring path. Record readings. This process will determine if cylinder is out-of-round and will also show any cylinder taper or bulge.
5. Refer to [Table 3-25](#). If cylinder is not scuffed or scored and is within service limit, see next section, [FITTING PISTON RINGS](#).

NOTE

If piston clearance exceeds service wear limit, cylinders should be re-bored and/or honed to next standard oversize, and refitted with the corresponding piston and rings. Do not fit piston tighter than 0.0007 in. (0.0178 mm). See [3.1 SPECIFICATIONS](#).

Table 3-25. Cylinder Bore Service Wear Limits

BORE SIZES	IN.	MM
Standard bore	3.5008	88.9203
0.005 in. OS bore (0.127 mm)	3.5050	89.0270
0.010 in. OS bore (0.254 mm)	3.5100	89.1540
0.020 in. OS bore (0.508 mm)	3.5200	89.4080
0.030 in. OS bore (0.762 mm)	3.5300	89.6620

Measuring Piston

Because of their complex shape, the pistons cannot be accurately measured with standard measuring instruments.

Pistons have an elliptical shape when viewed from the top and are barrel-shaped when viewed from the side. This barrel shape is not symmetrical.

Any damage to the piston will change its shape, which will lead to problems.

Fitting Cylinder to Piston

Since pistons cannot be accurately measured with standard measuring instruments, the bore sizes must be measured. Bore sizes are listed in [Table 3-26](#). Example: A 0.005 in. (0.127 mm) oversize piston will have the proper clearance with a bore size of 3.502 in. \pm 0.0002 in. (88.951 mm \pm 0.0051 mm).

Table 3-26. Final Cylinder Bore Sizes

BORE SIZES	IN.	MM
Standard bore*	3.4978	88.8441
0.005 in. OS bore (0.127 mm)	3.502	88.951
0.010 in. OS bore (0.254 mm)	3.507	89.078
0.020 in. OS bore (0.508 mm)	3.517	89.332
0.030 in. OS bore (0.762 mm)	3.527	89.586

*All bore sizes + 0.0002 in. (0.0051 mm)

Boring and Honing Cylinder

When cylinder requires oversize reboring to beyond 0.030 in. (0.762 mm), the oversize limit has been exceeded and cylinder must be replaced.

1. Bore cylinder with gaskets and torque plates attached. Bore to 0.003 in. (0.076 mm) under the desired finished size.
- 2.hone the cylinder to its finished size using a 280 grit rigid hone followed by a 240 grit flexible ball hone. Honing must be done with the torque plates attached. All honing must be done from the bottom (crankcase) end of the cylinder. Work for a 60° crosshatch pattern.

IMPORTANT NOTE

Failure to remove all abrasive particles may result in premature cylinder, piston and ring wear and possible engine failure.

3. Thoroughly wash the cylinder bore with liquid dish soap and warm water to remove all abrasive particles and residual grit. Continue cleaning until a clean cloth shows no evidence of dirt or debris.

WARNING

Compressed air can pierce the skin and flying debris from compressed air could cause serious eye injury. Wear safety glasses when working with compressed air. Never use your hand to check for air leaks or to determine air flow rates. (00061a)

4. Hot rinse the cylinder and dry with moisture free compressed air.
5. Immediately apply a thin film of clean engine oil to a clean white paper towel and thoroughly wipe the inside of the cylinder.

NOTE

After wiping the cylinder with a clean, oiled paper towel, the towel will be dark with contamination. Repeat this process using a new lightly oiled paper towel each time until the towel remains white. The cylinder is now clean.

Fitting Piston Rings

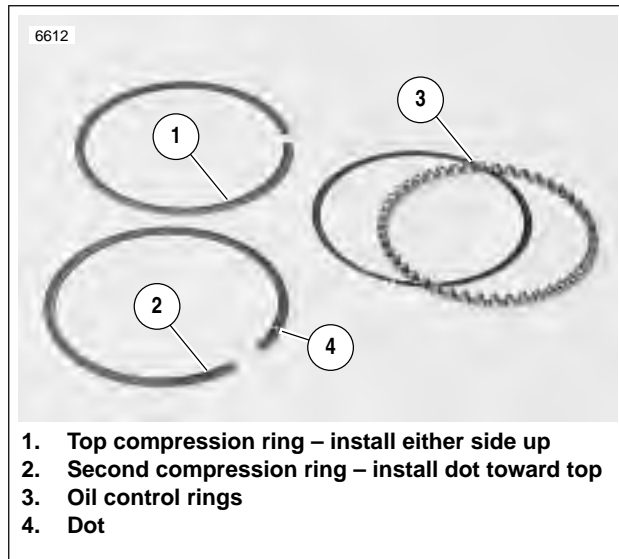


Figure 3-75. Piston Rings

See [Figure 3-75](#). Piston rings are of two types: compression and oil control (3). The top (1) and second (2) compression rings are positioned in the top and second upper piston ring grooves. The dot (4) on the second compression ring must face upward. Ring sets are available to fit standard and oversize pistons.

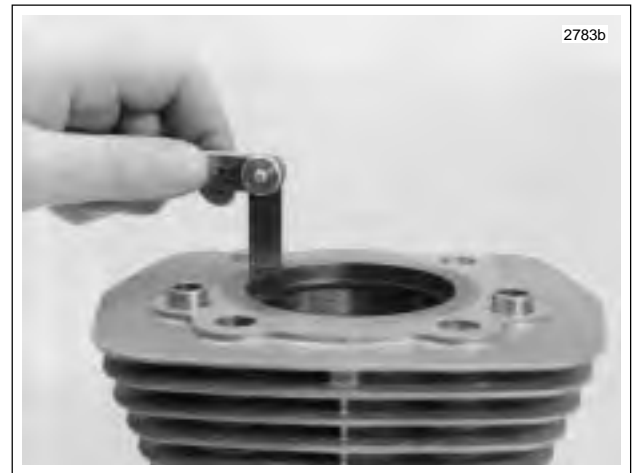


Figure 3-76. Measuring Ring End Gap

Piston ring sets must be properly fitted to piston and cylinder:

1. See [Figure 3-76](#). Insert the **new** ring into the cylinder, square it in the bore using the top of the piston and measure the ring end gap with a feeler gauge. Do not use the ring if the end gap does not fall within the following specifications. Refer to [Table 3-27](#).

NOTE

Ring end gap dimensions also apply to oversize rings. Replace ring if end gap exceeds specification. If end gap is under specification, filing is permissible.

Table 3-27. Piston Ring End Gap

RING	IN.	MM
Top compression	0.010-0.020	0.25-0.51
2nd compression	0.014-0.024	0.36-0.61
Oil control ring rails	0.010-0.050	0.25-1.27

NOTE

The same piston may be used if cylinder bore was not changed, unless it is scuffed or grooved. If re-using piston, replace piston rings and hone the cylinder walls with a No. 240 grit flexible hone to facilitate ring seating.



Figure 3-77. Installing Piston Rings using Transmission Shaft Retaining Ring Pliers (Part No. J-5586)

- See [Figure 3-77](#). Apply engine oil to piston grooves. Use TRANSMISSION SHAFT RETAINING RING PLIERS (Part No. J-5586) to slip compression rings over piston into their respective grooves. Be extremely careful not to over expand, twist rings or damage piston surface when installing rings.

NOTE

Install second compression ring with dot towards top.

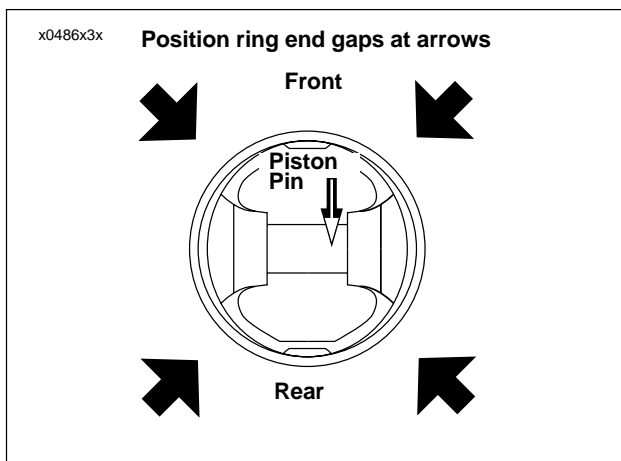


Figure 3-78. Ring End Gap Position

- See [Figure 3-78](#). Install rings so end gaps of adjacent rings are a minimum of 90° apart. Ring gaps are not to be within 10° of the thrust face centerline.

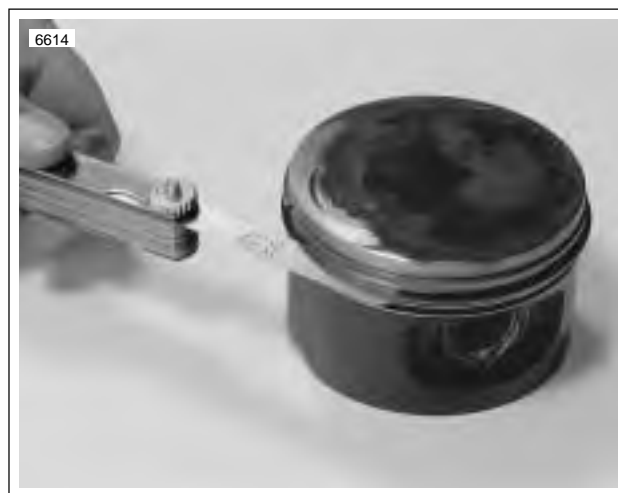


Figure 3-79. Measuring Ring Clearance in Groove

- See [Figure 3-79](#). Check for proper side clearance with thickness gauge, as shown. See [3.1 SPECIFICATIONS](#).

NOTE

If the ring grooves are clean and the side play is still not correct, replace the rings, the piston or both.

Connecting Rod Bushing

REMOVAL/INSTALLATION

When connecting rod bushing is worn to excessive pin clearance of 0.002 in. (0.051 mm) or more it must be replaced.

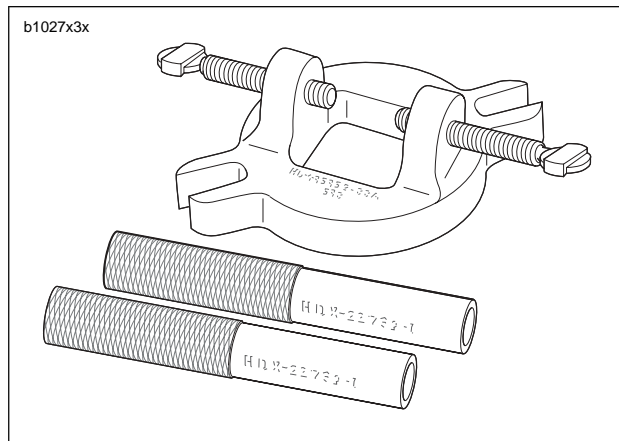
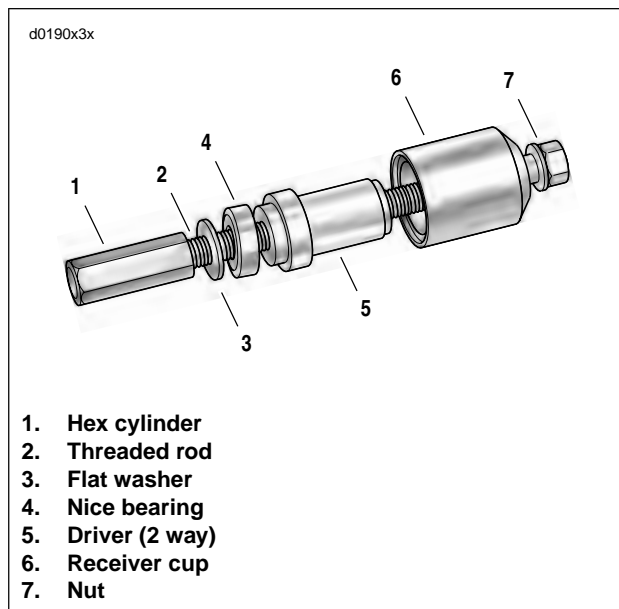


Figure 3-80. Connecting Rod Clamping Tool (Part No. HD-95952-33B)

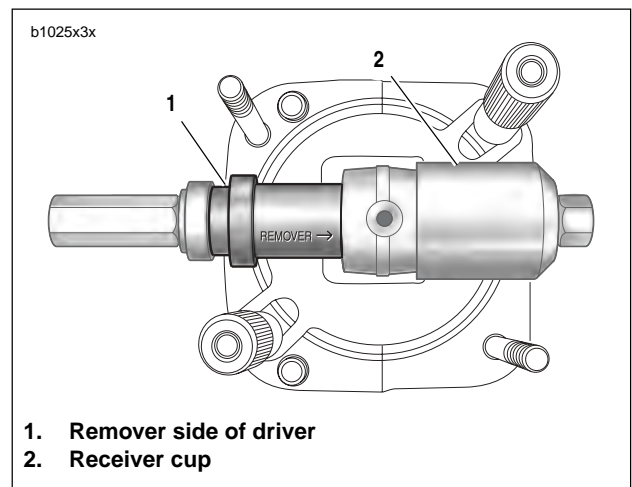
1. See [Figure 3-80](#). Secure connecting rod with CONNECTING ROD CLAMPING TOOL (Part No. HD-95952-33B).



1. Hex cylinder
2. Threaded rod
3. Flat washer
4. Nice bearing
5. Driver (2 way)
6. Receiver cup
7. Nut

Figure 3-81. Connecting Rod Bushing Remover/Installer (Part No. HD-95970-32D)

2. See [Figure 3-81](#). Attach PISTON PIN BUSHING TOOL (Part No. HD-95970-32D) to the connecting rod.



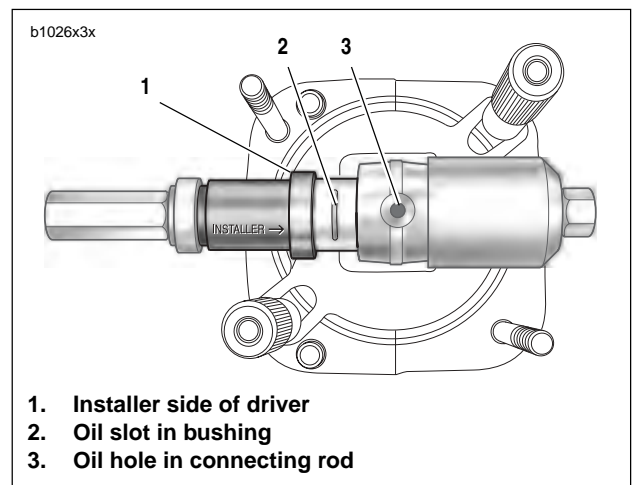
1. Remover side of driver
2. Receiver cup

Figure 3-82. Removing Wrist Pin Bushing

NOTE

See [Figure 3-82](#). The receiver cup fits on one side of the rod while the driver fits on the opposite side as shown.

3. Use two box wrenches and push worn bushing from connecting rod.
4. Remove piston pin bushing tool from connecting rod.
5. Remove bushing from receiver cup.



1. Installer side of driver
2. Oil slot in bushing
3. Oil hole in connecting rod

Figure 3-83. Installing New Wrist Pin Bushing

6. See [Figure 3-83](#). Place **new** bushing between connecting rod and driver.

NOTE

The driver must be attached facing the opposite direction as it was for removal of the bushing.

7. Clean up and size bushing to 0.0010-0.0005 in. (0.0254-0.0127 mm) undersize using REAMER (Part No. HD-94800-26A). Sizing bushing with less than 0.00125 in. (0.03175 mm) clearance can result in a bushing loosening and/or seized pin in rod.
- 8.hone bushing to final size using WRIST PIN BUSHING HONE (Part No. HD-35102). Use a liberal amount of honing oil to prevent damage to hone or bushing. Use care to prevent foreign material from falling into the crankcase.

ASSEMBLY/INSTALLATION

NOTE

Piston must be installed with the arrow, at the top of the piston, pointing towards the front of the engine.

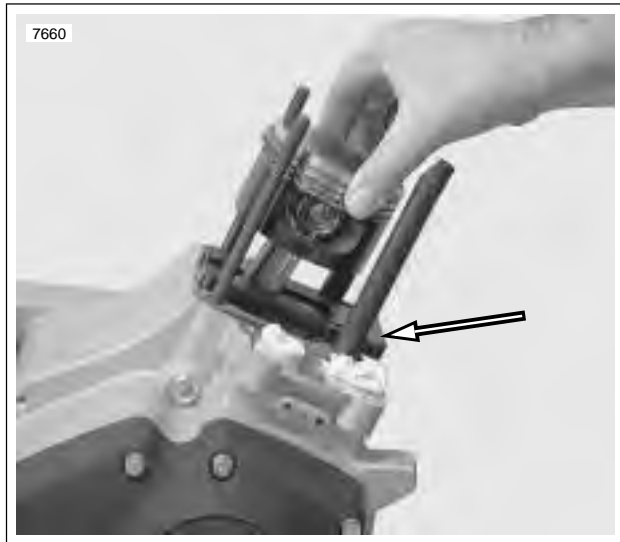


Figure 3-84. Piston Support Plate

1. See [Figure 3-84](#). Place PISTON SUPPORT PLATE (Part No. HD-42322) in position as shown.
2. Install piston assembly over connecting rod.
3. Install piston pin.

IMPORTANT NOTE

Always use new retaining ring. Make sure retaining ring groove is clean and that ring seats firmly in groove. If it does not, discard the ring. Never install a used retaining ring or a new one if it has been installed and then removed for any reason. A loosely installed ring will come out of the piston groove and damage cylinder and piston beyond repair.

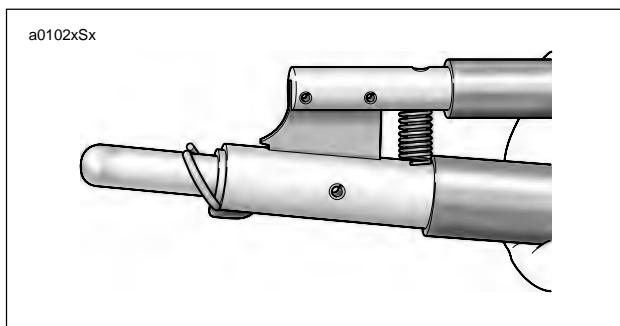
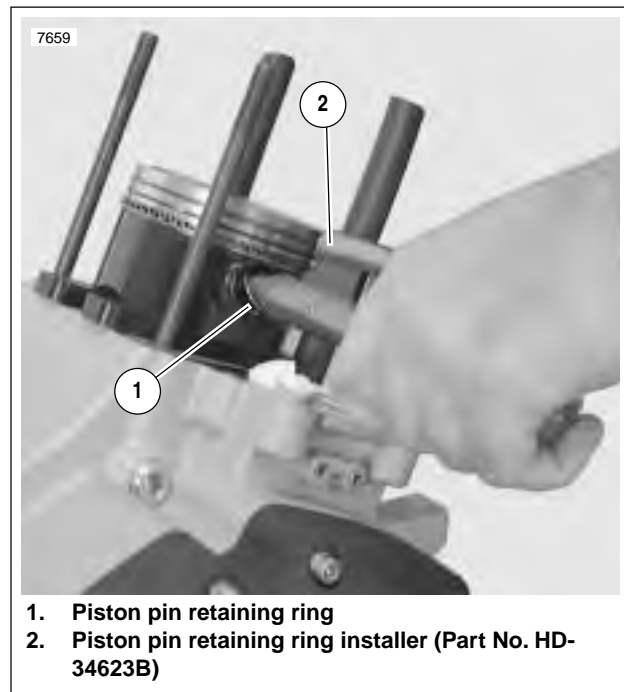


Figure 3-85. Installing Piston Pin Retaining Ring



1. Piston pin retaining ring
2. Piston pin retaining ring installer (Part No. HD-34623B)

Figure 3-86. Installing Piston Retaining Rings

4. See [Figure 3-86](#). Install **new** piston pin retaining rings (1) using PISTON PIN RETAINING RING INSTALLER (2) (Part No. HD-34623B). Place **new** retaining ring on tool with gap pointing up. See [Figure 3-85](#).

NOTE

Make sure the ring groove is clean. Ring must be fully seated in the groove with the gap away from the slot at the bottom.

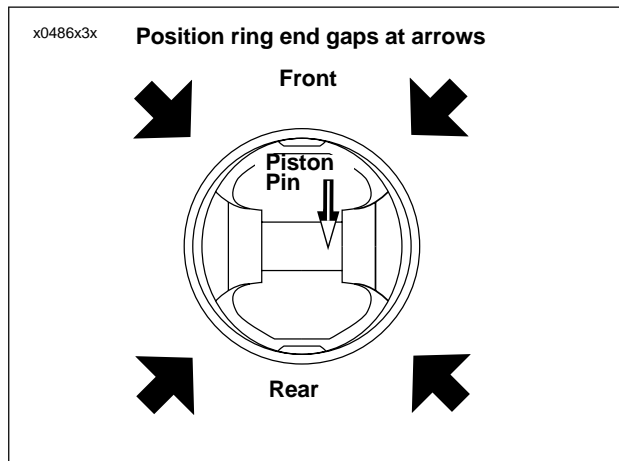


Figure 3-87. Ring End Gap Position

- See Figure 3-87. Make sure the piston ring end gaps are properly positioned as shown.

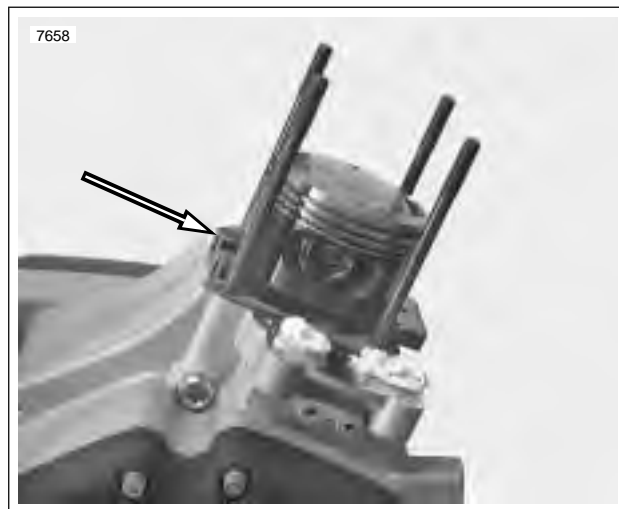


Figure 3-88. Piston Support Plate (Part No. HD-42322)

- See Figure 3-88. Turn engine until piston is resting on top of PISTON SUPPORT PLATE (Part No. HD-42322) top dead center.
- Lubricate cylinder wall, piston, pin and rod bushing with engine oil.



Figure 3-89. Compressing Piston Rings Using Piston Ring Compressor (Part No. HD-96333-51C)

- See Figure 3-89. Compress the piston rings using PISTON RING COMPRESSOR (Part No. HD-96333-51C).
- Remove protective sleeves from cylinder studs. Install a **new** cylinder base gasket. Make sure the piston does not bump the studs or crankcase.
- Install cylinder over piston.
- Remove PISTON RING COMPRESSOR.
- Assemble cylinder head. See 3.5 CYLINDER HEAD.
- Install cylinder head. See 3.5 CYLINDER HEAD.

NOTES

CHECKING AND ADDING OIL

Check engine oil level in oil reservoir at least once every 500 miles (800 km). Check level more frequently if engine uses more oil than normal or if vehicle is operated under harsh conditions. Check oil when engine is warmed up to operating temperature.

CHANGING OIL AND FILTER

After a new engine has run its first 1000 miles (1600 km) and at 5000 mile (8000 km) intervals or annually thereafter, completely drain oil reservoir of used oil. If riding habits include severe dust conditions, operation at temperature above 80° F, extensive idling, speeds in excess of 65 m.p.h. (105 km/h) and/or extensive two up riding or similar loads the oil should be changed at 2500 mile intervals. Refill with fresh oil. Always change oil filter when changing engine oil.

NOTE

See [1.5 ENGINE LUBRICATION SYSTEM](#) for more information on checking oil level and changing oil and filter.

WINTER LUBRICATION

Normal fuel combustion in a gasoline engine produces water vapor and carbon dioxide along with other gases and particulates. When first starting and warming an engine, some of the water vapor that gets into the engine crankcase condenses to form liquid water. If the engine is driven long enough to thoroughly warm the crankcase, most of this liquid water is again vaporized and exhausted through the crankcase breather system.

A moderately driven vehicle making short runs may not be able to vacate water vapors allowing liquid water to accumulate in the oil reservoir. This is especially true if the vehicle is operated in cold weather. In freezing weather, an accumulation of water in the engine oil may become slush or ice, which can block oil lines and lead to severe engine damage. Water remaining in the engine oil for long periods of time can form an acidic sludge that is corrosive to metal engine parts and causes accelerated wear of moving components.

In winter the oil change interval should be shorter than normal. The colder the weather, the shorter the recommended oil change interval. A vehicle used only for short runs in cold weather must have the engine oil drained frequently.

GENERAL

See [Figure 3-90](#). Engine oil runs through the frame backbone which serves as the oil reservoir. From the bottom of the reservoir, the vent hose and the return hose run downward below the battery tray. A rubberized clamp secure the hoses in place.

A T-fitting on the bottom left side of the oil reservoir, supplies the feed hose and the oil drain hose.

After diverging from the feed and return hoses, the vent hose continues on to the right side of the motorcycle. Here the vent hose connects to an elbow fitting on the gearcase cover.

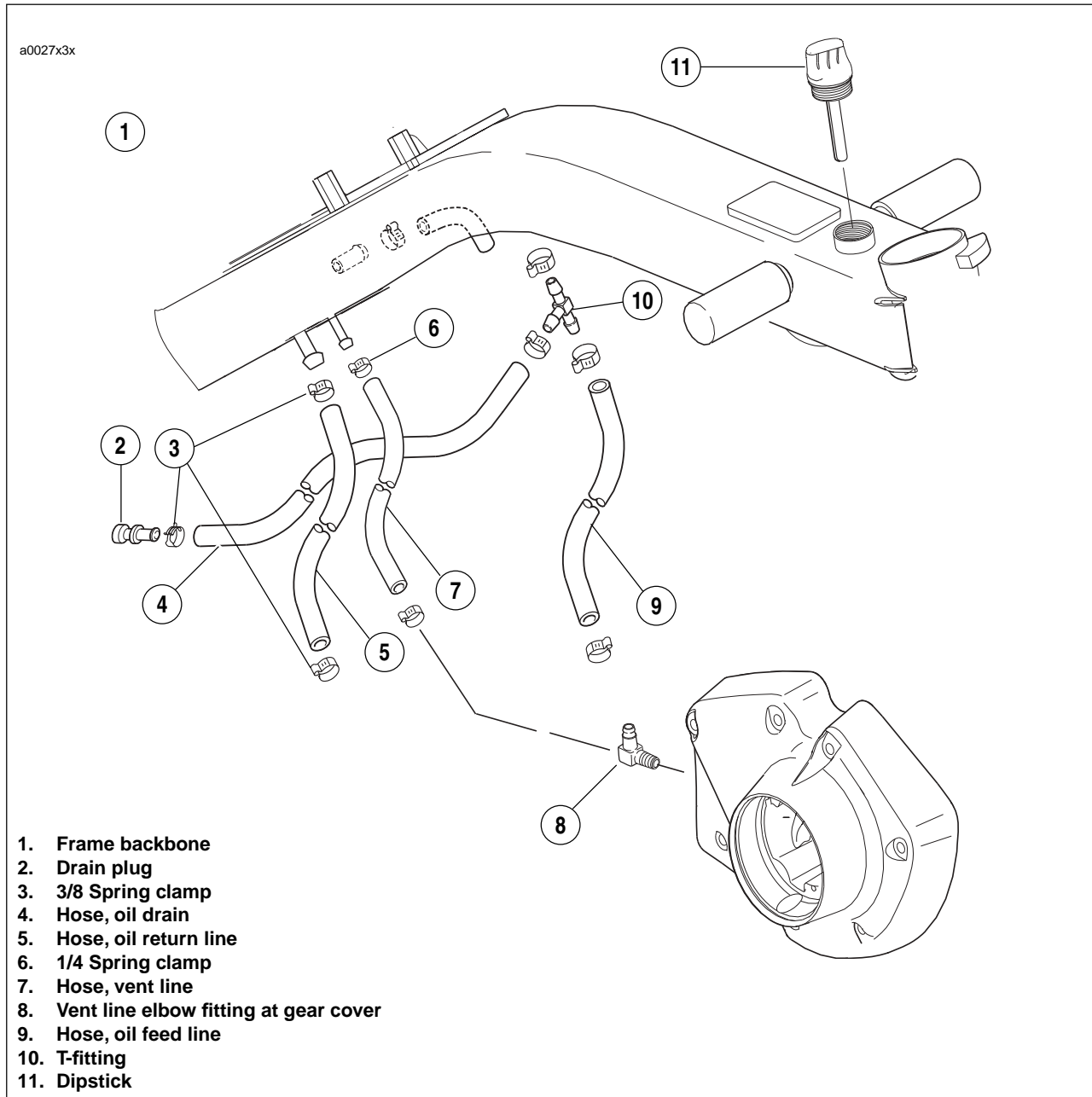


Figure 3-90. Oil Reservoir and Hose Routing

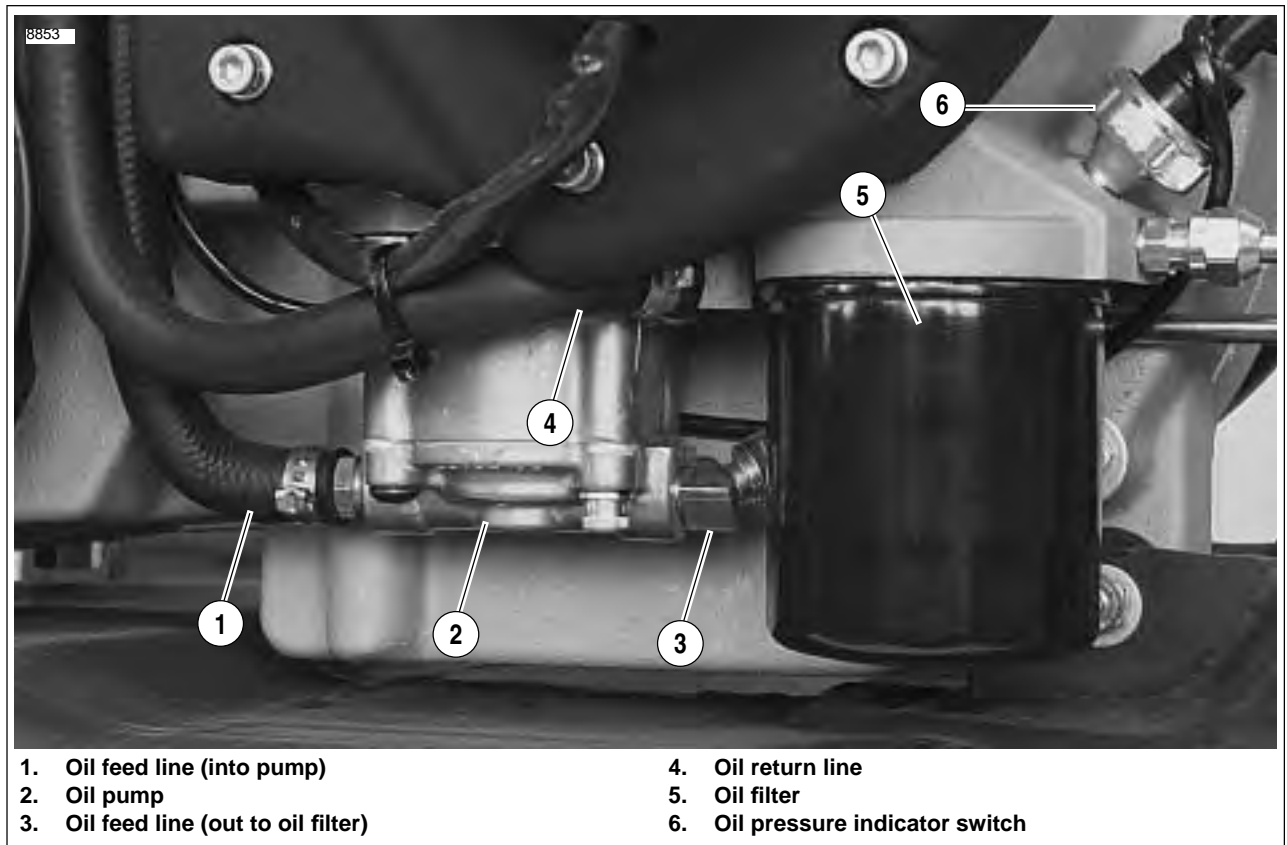


Figure 3-91. Oil Pump Connections

See [Figure 3-91](#). The feed and return hoses run together alongside the engine and forward to the oil pump. The feed hose attaches to the rear most oil pump fitting; the return hose connects forward and above.

See [Figure 3-92](#). The drain hose attaches to the left side of the footpeg support bracket.

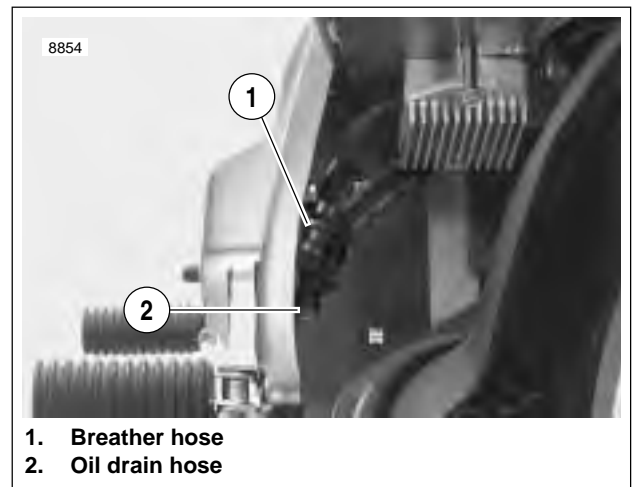


Figure 3-92. Oil Drain Hose

GENERAL

See [Figure 3-93](#). The oil pressure indicator switch is a pressure-actuated diaphragm-type switch. When oil is not circulating through the system or when oil pressure is low, spring tension holds the switch contacts closed, thereby completing the signal light circuit and causing the indicator lamp to illuminate.

OIL PRESSURE SIGNAL LIGHT

The oil pressure signal light turns ON when:

- Ignition switch is turned on prior to starting engine.
- Oil is not circulating through the running engine.
- Oil pressure is abnormally low in the running engine.
- Engine is idling below 1000 RPM.

The oil pressure signal light turns OFF when:

- Oil is circulating with adequate pressure through the engine running at 1000 RPM or greater.

Troubleshooting information is listed in [Table 3-28](#).

NOTE

If the ignition is turned back on immediately after the engine is stopped, the oil light may not turn on right away because of oil pressure retained in the filter housing.

OIL PRESSURE

The oil pump is non regulatory and delivers its entire volume of oil under pressure to the oil filter mount. When an engine is cold, the engine oil will be more viscous (i.e., thicker).

When an engine is operated at high speeds, the volume of oil circulated through the oiling system increases, resulting in higher oil pressure. As engine speed is reduced, the volume of oil pumped is also reduced, resulting in lower oil pressure.

To check oil pressure, use OIL PRESSURE GAUGE (Part No. HD-96921-52B) and OIL PRESSURE GAUGE ADAPTER (Part No. HD-96940-58). Remove oil pressure indicator switch and insert pressure gauge fitting.

Ride motorcycle at least 20 miles (32 km) at or above 50 MPH (80 KM/H) until engine oil reaches normal operating temperature. At 2500 RPM, oil pressure will vary from 10-12 psi (69-83 KPa). At idle speed (950-1050 RPM), oil pressure will vary from 6-8 psi (42-55 KPa).

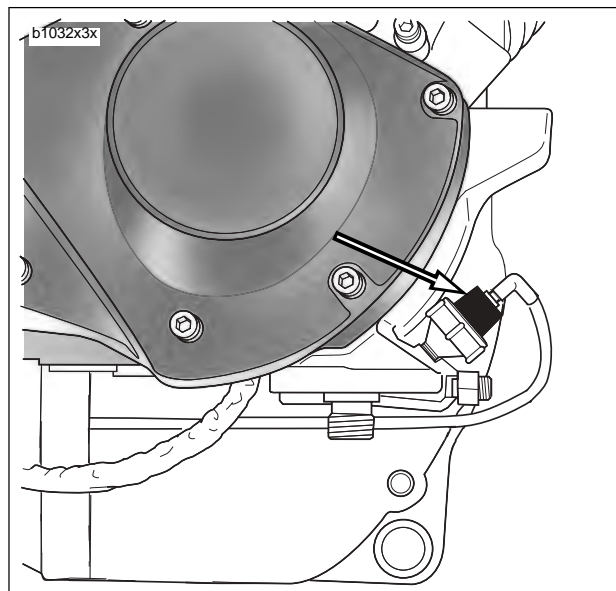


Figure 3-93. Oil Pressure Indicator Switch

Table 3-28. Troubleshooting Oil Pressure Signal Light

OIL PRESSURE SIGNAL LIGHT	PROBABLE CAUSES
Stays on at speeds above idle.	<ul style="list-style-type: none"> ● Empty oil reservoir. ● Clogged feed line (ice and sludge, freezing temperatures). ● Air-bound oil line. ● Grounded oil switch wire. ● Malfunctioning signal switch. ● Diluted oil. ● Malfunctioning check valve (see 3.13 OIL FILTER MOUNT).
Flickers at idle.	<ul style="list-style-type: none"> ● Incorrect idle speed. Malfunctioning or improperly installed check valve (see 3.13 OIL FILTER MOUNT).
Does not glow when ignition is turned on (prior to operating engine).	<ul style="list-style-type: none"> ● Malfunctioning signal switch. ● Malfunction in wiring. ● Burned-out signal bulb. ● Dead battery (see NOTE).

GENERAL

See [Figure 3-94](#). On piston downstroke, a mixture of crankcase air and oil mist is vented up the push rod covers to the upper rocker box. Air is allowed to escape the rocker box by exiting the positive crankcase vent valve located on top of the rocker box.

The oil mist collects and eventually returns to the crankcase through oil passageways in the cylinder head.

The crankcase air passes through the breather assembly to the positive crankcase vent valve (PCV) located on top of the rocker box cover. From the PCV the air enters the crankcase breather hose. The crankcase breather hose splits with one hose (crankcase breather hose) going to the air cleaner and the other hose (crankcase breather drain hose) going to the footrest support bracket. Crankcase air is routed to the air cleaner box where it is directed into the carburetor's venturi. Any residual oil drains to the crankcase breather drain hose located behind the right footrest support (located by the oil tank drain hose). The crankcase breather drain hose should be drained at each oil change.

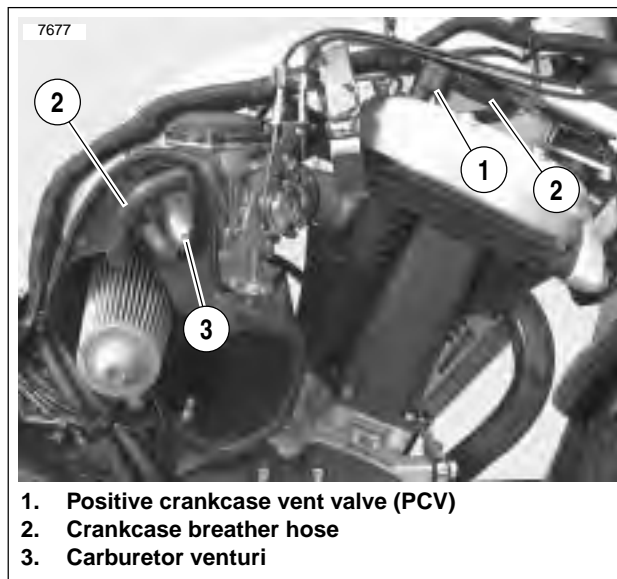


Figure 3-94. Crankcase Breathing System

GENERAL

1. Oil is gravity-fed from the oil reservoir to the gerotor-style oil pump through a **feed hose**. Oil enters the **feed section** and fills a cavity located under the feed pump.

NOTE

For a complete explanation of the gerotor pump sets see 3.12 OIL PUMP.

2. The feed pump transfers oil from the inlet cavity through the **external steel line** to the oil filter mount.
3. Oil flows through the **filter mount cavity** to the oil filter.
4. Oil enters the peripheral cavity of the **oil filter**, passes through the filtering medium into the central cavity of the oil filter, and flows into the filter adapter (fitting which connects filter to filter mount).
5. Adequate oil pressure in the filter mount cavity activates the **oil pressure signal light switch** and shuts off the oil pressure signal light.
6. Oil flowing from the filter adapter opens the **check ball**. The check ball opens at 4-6 psi (28-41 kPa) oil pressure.
7. With the check ball open, oil flows into the **crankcase feed galley**.
8. Oil flows through the feed galley in the crankcase to the tappet blocks and hydraulic lifters. **Cross-drilled passages** intersect the main feed galley and carry oil to both hydraulic lifters.
9. Oil also enters an **intersecting passage** in the gearcase cover. Oil flow is then routed to the crankshaft area.
10. Oil enters a hole in the end of the **pinion gear shaft** and travels to the right flywheel where it is routed through the flywheel to the **crankpin**. Oil is forced through the crankpin to properly lubricate the rod bearing assembly.
11. Oil flows up passages in the **push rods** to the rocker arm shafts and bushings.
12. The valve stems are lubricated by oil supplied through drilled oil holes in the **rocker arms**.
13. Oil collected in the push rod areas of the cylinder heads flows down the **push rod cover**, through drain holes in the **tappet blocks** and into the gearcase. After providing lubrication to the gearcase components, the oil flows to the left side of the oil pump.
14. Feed oil to the rocker area is returned to the crankcase through a **passage** in the head and cylinder.
15. Oil collected in the **sump** is splash-fed to the pistons, cylinder walls and flywheel components.
16. A single **piston oil jet** cools the bottom of the piston with a spray of oil.
17. Oil collected in the sump area returns to the scavenge section of the oil pump through a **passage** located in the rear section of the sump. Oil flow to the pump is accomplished by the scavenging effect of the pump and by the pressure created by the downward stroke of the pistons.
18. Return oil fills a **cavity** above the pump's return gears. The return gears pump oil back to the oil reservoir.

GENERAL

See [Figure 3-95](#). The oil pump consists of two gerotor gear sets, feed and return, housed in one pump body. The feed set distributes oil to the engine, the scavenge set returns oil to the tank/frame reservoir.

A gerotor-type gear set has two parts — an inner and an outer gerotor. The inner gerotor has one less tooth than the outer gerotor. Both gerotors have fixed centers which are off-set to each other.

In a gerotor gear set, oil is transferred from inlet to outlet as it is trapped between the rotating inner and outer gerotors.

See [Figure 3-95](#). Gravity-fed oil from the oil reservoir enters the pump through the feed hose connector. It is forced by the gerotor feed set through a hose to the oil filter. Return oil from the flywheel compartment is drawn back into the pump and is forced by the gerotor scavenge set back to the oil reservoir.

The oil pump seldom needs servicing. Before you disassemble an oil pump suspected of not producing adequate oil pressure, be sure that all possible related malfunctions have been eliminated:

1. Make sure all oil hose clamps are tight and that hoses are not pinched or damaged.
2. Check level and condition of oil in tank. Pressure will be affected if oil is diluted. In freezing weather, proper circulation of oil can be affected if the oil feed hose becomes clogged with ice or sludge.
3. Check for a grounded oil pressure switch wire or faulty switch if oil indicator light fails to go out with engine running.

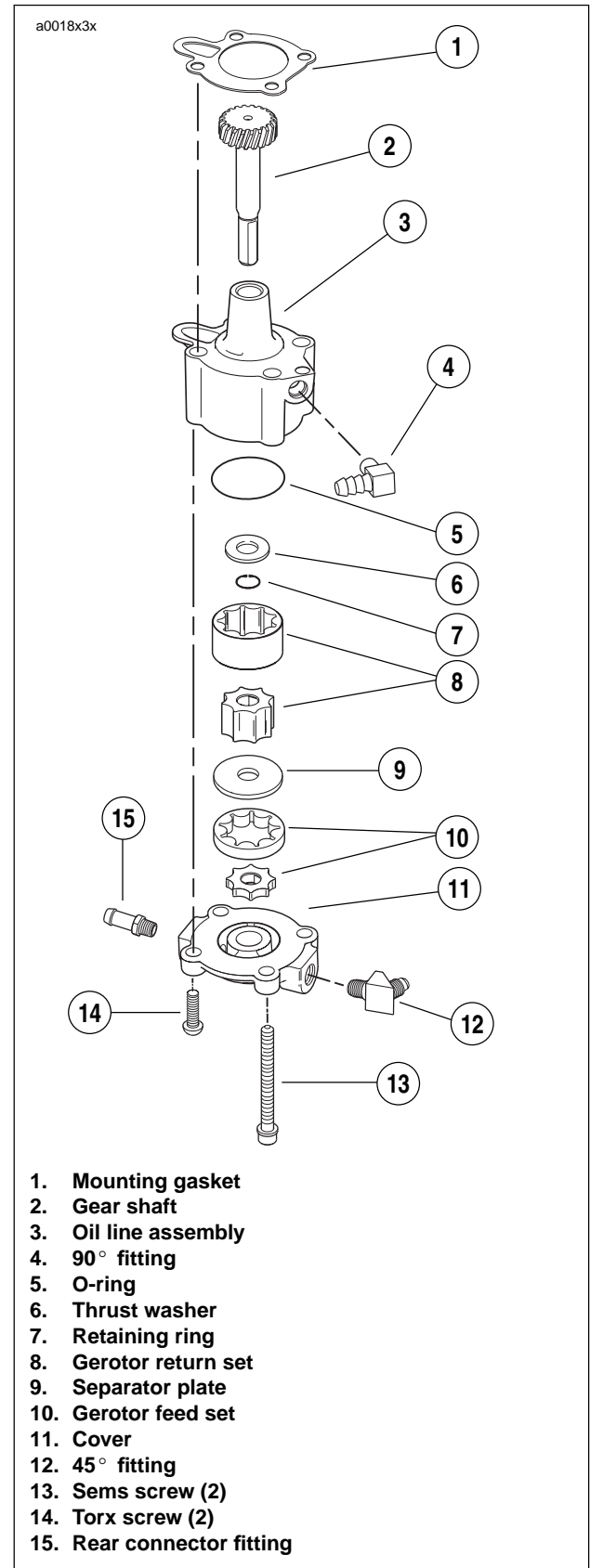


Figure 3-95. Oil Pump

REMOVAL/DISASSEMBLY

NOTE

Oil pump can be removed with engine in frame and without removing gearcase cover.

1. See ENGINE LUBRICATION SYSTEM section. Drain oil reservoir.
2. Remove and discard oil filter.

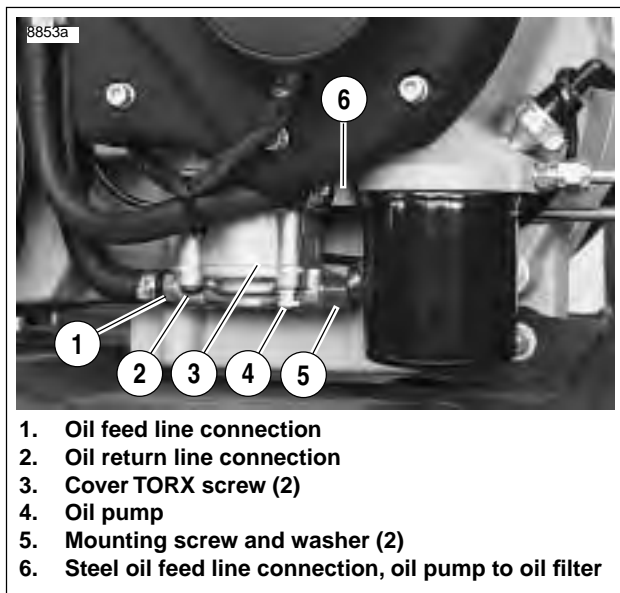


Figure 3-96. Oil Pump Hardware

3. See Figure 3-96. Disconnect feed hose and oil filter hose connection.

NOTE

Loosen nut on oil filter hose connection and then remove pressurized hose.

4. Carefully remove mounting screws and washers only. Pump will drop with screws removed. Discard mounting gasket.
5. Remove clamp and detach return hose connection.
6. See Figure 3-96. Remove cover TORX screws. Lift cover off body.
7. Remove and discard o-ring.
8. See Figure 3-95. Slide both pieces of gerotor feed set, separator plate and both pieces of gerotor scavenge set off gear shaft.
9. Remove and discard retaining ring. Remove thrust washer and gear shaft.

CLEANING AND INSPECTION

WARNING

Compressed air can pierce the skin and flying debris from compressed air could cause serious eye injury. Wear safety glasses when working with compressed air. Never use your hand to check for air leaks or to determine air flow rates. (00061a)

1. Clean all parts in cleaning solvent. Blow out holes and oil passages with compressed air.

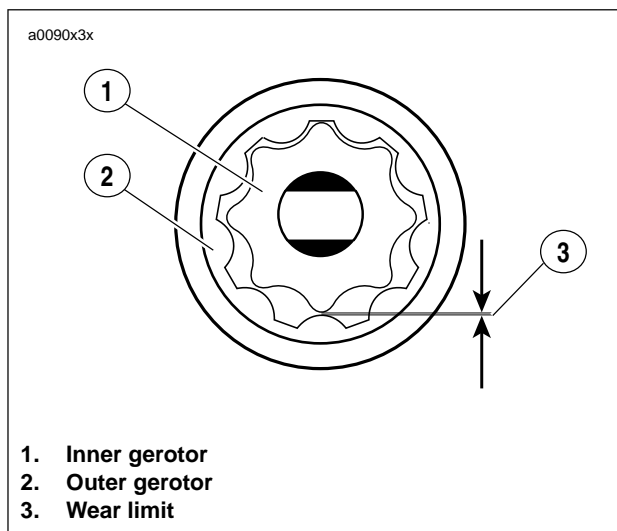


Figure 3-97. Gerotor Wear Limits

2. See Figure 3-97. Inspect both gerotor sets for wear.
 - a. Mesh pieces of each set together as shown.
 - b. Use a feeler gauge to determine clearance.
 - c. The SERVICE WEAR LIMIT between gerotors is 0.004 in. (0.102 mm). Replace gerotors as a set if clearance exceeds this dimension.
 - d. Measure thickness of feed gerotors with a micrometer. Replace gerotors as a set if they are not the same thickness.
3. See Figure 3-98. Check gear shaft teeth for damage or wear. Replace if necessary.

ASSEMBLY/INSTALLATION

NOTE

Liberally coat all moving parts with clean engine oil to ensure easy assembly and smooth operation at start-up.

1. Install gear shaft through body. Position thrust washer over end of shaft. Install **new** retaining ring into groove in shaft.
2. Insert inner gerotor of the gerotor scavenge set over gear shaft.
3. Place outer gerotor over inner gerotor to complete scavenge set.
4. See [Figure 3-98](#). Install gerotor separator plate (1).
5. Install a **new** o-ring (2) into groove in pump body.
6. Place gerotor feed set over gear shaft.
7. Place cover onto pump body. Install cover TORX screws. Tighten to 70-80 **in-lbs** (8-9 Nm).
8. Place **new** mounting gasket in position.

NOTE

*Use **new** hose clamps. If fittings were removed, use TEFLON® PIPE SEALANT or HYLOMAR® on fitting threads.*

9. Attach return hose connection.
10. Secure pump to crankcase with mounting screws. Tighten to 125-150 **in-lbs** (14-17 Nm).
11. Attach feed hose and oil filter hose connection.
12. Attach clamp to hose.
13. Install **new** oil filter. See [1.5 ENGINE LUBRICATION SYSTEM](#).
14. See [1.5 ENGINE LUBRICATION SYSTEM](#). Check engine oil level. Add oil to correct level if needed.

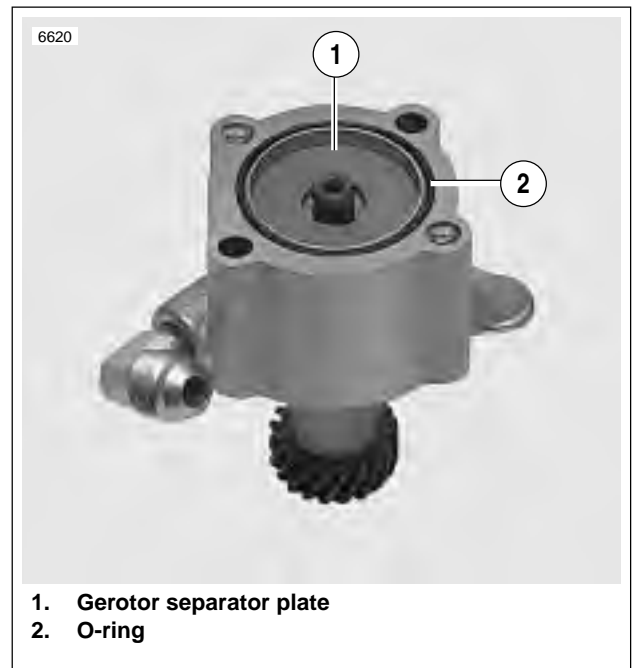


Figure 3-98. Oil Pump Assembly

GENERAL

See [Figure 3-99](#). Oil is pressure-fed from the oil pump to the filter mount via rigid external steel line. Oil travels through the filter mount into the filter through the outer filter holes.

Adequate oil pressure activates the oil pressure indicator switch in the filter mount, which turns off the oil pressure indicator lamp.

The check ball in the filter adapter “opens” at 4-6 psi (28-41 kPa) oil pressure. Filtered oil leaves the filter, flowing past the check ball.

DISASSEMBLY

1. Drain oil reservoir and remove filter. See [1.5 ENGINE LUBRICATION SYSTEM](#).
2. See [Figure 3-99](#). Remove filter adapter (6) from filter mount (3). Remove check ball (5) and spring (4).
3. Detach indicator lamp wire (2) from oil pressure indicator switch (1). Remove switch using OIL PRESSURE SENDING UNIT WRENCH (Part No. HD-41675).

CLEANING AND INSPECTION

WARNING

Compressed air can pierce the skin and flying debris from compressed air could cause serious eye injury. Wear safety glasses when working with compressed air. Never use your hand to check for air leaks or to determine air flow rates. (00061a)

Thoroughly clean all parts in cleaning solvent. Blow out holes and passages using compressed air.

ASSEMBLY

NOTE

Use *TEFLON PIPE SEALANT* or *HYLOMAR* on all fittings installed to oil filter mount.

1. See [Figure 3-99](#). Install oil pressure indicator switch using (1) OIL PRESSURE SENDING UNIT WRENCH (Part No. HD-41675). Tighten to 50-70 **in-lbs** (6-8 Nm).
2. Attach indicator lamp wire (2) to oil pressure indicator switch (1).

NOTE

The filter adapter has identical ends; either end may be installed into the filter mount.

3. Apply several drops of Loctite 243 (blue) to last few threads on that end of the filter adapter (6) which is installed into filter mount (3). Do not apply Loctite to adapter threads on filter element side.

4. Install filter mount components.
 - a. Place spring (4) and check ball (5) into threaded hole at center of mount.
 - b. Push threaded end of filter adapter (6) (with Loctite) against check ball to compress spring.
 - c. Screw adapter into threaded hole. Tighten to 96-144 **in-lbs** (11-16 Nm).
5. Install a **new** filter and fill oil reservoir with proper oil. See [1.5 ENGINE LUBRICATION SYSTEM](#).

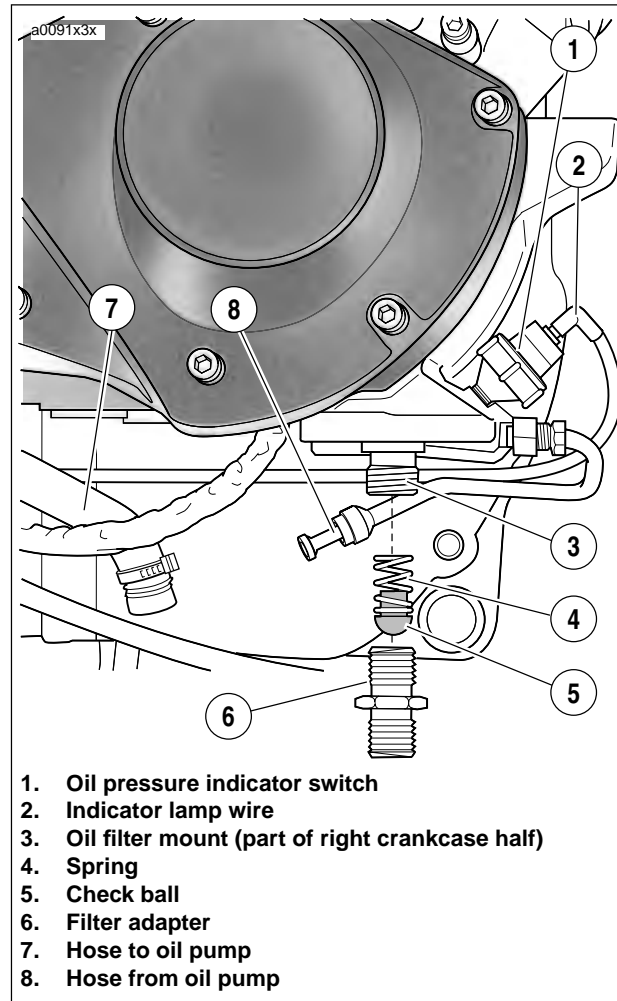


Figure 3-99. Oil Filter Mount Assembly

GENERAL

See [Figure 3-100](#). The lifter assembly consists of a hydraulic lifter and roller. The lifter and roller, under compression force from valve spring, follow the surface of the revolving cam. The up-and-down motion produced is transmitted to the valve by the push rod and rocker arm. The lifter contains a piston (or plunger) and cylinder; it also contains a check valve, which allows the unit to fill with engine oil, thereby reducing clearance in the valve train.

When a lifter is functioning properly, the assembly operates with minimal lifter clearance. The unit automatically compensates for heat expansion to maintain a no-clearance condition.

It is normal for lifters to click when engine is started after standing for some time. Hydraulic lifters have a definite leak-down rate which permits the oil in the lifters to escape. This is necessary to allow units to compensate for various expansion conditions of parts and still maintain correct clearance operation. Lifters are functioning properly if they become quiet after a few minutes of engine operation.

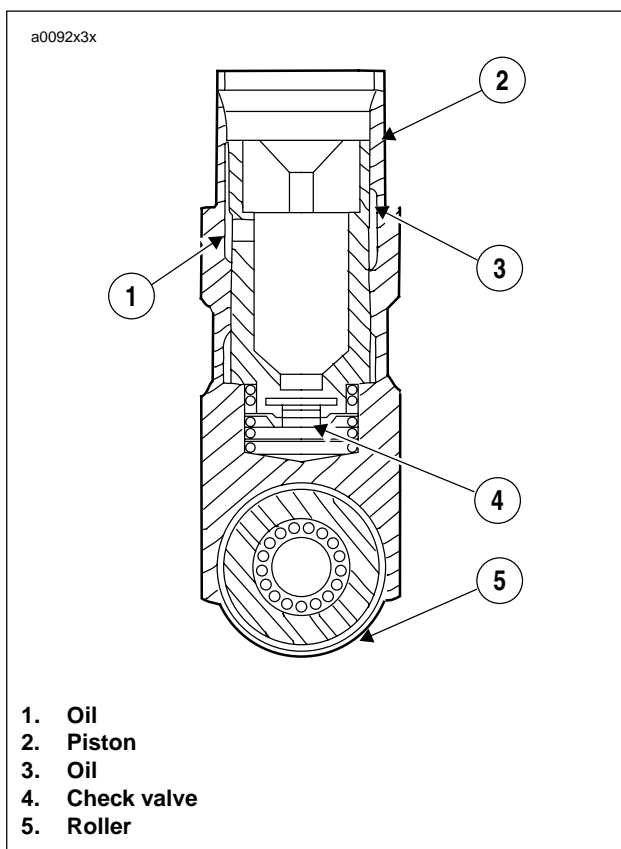


Figure 3-100. Lifter Assembly (Typical)

REMOVAL

1. Clean all dirt from around crankcase. Blow loose particles from area with compressed air.
2. Remove the lower rocker cover. Pull each push rod upward through top of cylinder head. See [3.5 CYLINDER HEAD](#).
3. Remove cylinder head assembly. See [3.5 CYLINDER HEAD](#).
4. See [Figure 3-102](#). Remove push rod cover.
 - a. Remove screws.
 - b. Remove push rod cover.
 - c. Remove gasket and o-rings. Discard parts.
5. Remove both valve hydraulic lifters.
 - a. Remove anti-rotation screws.
 - b. Remove lifters from crankcase bore using a thin-bladed screwdriver. Mark the location and orientation (front/back) of each lifter.

CLEANING AND INSPECTION

⚠ WARNING

Compressed air can pierce the skin and flying debris from compressed air could cause serious eye injury. Wear safety glasses when working with compressed air. Never use your hand to check for air leaks or to determine air flow rates. (00061a)

1. Clean all parts, except roller/lifter assembly, thoroughly in solvent. Blow dry with compressed air.

NOTE

Inside and outside micrometers used for measuring tappets and tappet guides must be calibrated to ensure accurate readings.

2. Inspect valve lifters for excessive clearance in guide. Accurately measure lifter bore inner diameter with a gauge.
 - a. Clearance should be within 0.0008-0.0020 in. (0.0203-0.0508 mm).
 - b. Fit a **new** lifter and/or replace crankcases if clearance exceeds SERVICE WEAR LIMIT of 0.0030 in. (0.076 mm).
3. Check lifter roller freeplay.
 - a. Roller clearance on pin should be within 0.0006-0.0010 in. (0.0152-0.0254 mm).
 - b. Replace lifters if clearance exceeds SERVICE WEAR LIMIT of 0.0015 in. (0.0381 mm).
4. Check lifter roller end clearance.
 - a. End clearance should be within 0.008-0.022 in. (0.203-0.559 mm).
 - b. Replace lifters if clearance exceeds SERVICE WEAR LIMIT of 0.026 in. (0.660 mm).
5. Soak lifters in clean engine oil. Keep covered until assembly.

INSTALLATION

1. See [Figure 3-101](#). Rotate engine so that both lifters will be installed on the base circle of the cam.
2. Apply a liberal amount of engine oil to each lifter assembly (especially the roller needles) for smooth initial operation.

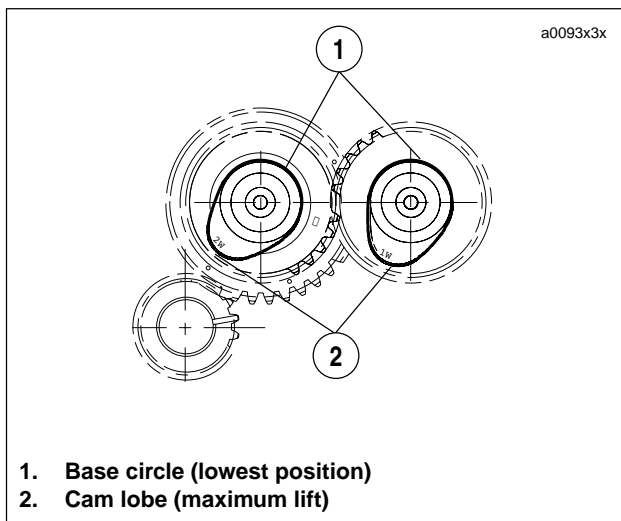


Figure 3-101. Base Circle

3. See [Figure 3-102](#). Insert lifter into bore in crankcase. Rotate lifter so that flats at upper end of lifter face the front and rear of the engine. If the lifter is installed incorrectly, anti-rotation screws cannot be inserted.
4. Secure lifters in place.
 - a. Install anti-rotation screws with washers in the holes in lifter block.
 - b. Tighten anti-rotation screws to 55-65 **in-lbs** (6-7 Nm).
5. Install push rod cover.
 - a. Slide **new** gasket cover over bottom of push rod cover.
 - b. Position push rod cover onto crankcase.
 - c. Install screws through holes in push rod cover into tapped holes in crankcase. Tighten screws evenly to 30-40 **in-lbs** (3-5 Nm).
 - d. Place **new** o-rings on top of push rod cover.
6. Install push rods, cylinder head, lower and upper rocker covers. See [3.5 CYLINDER HEAD](#).

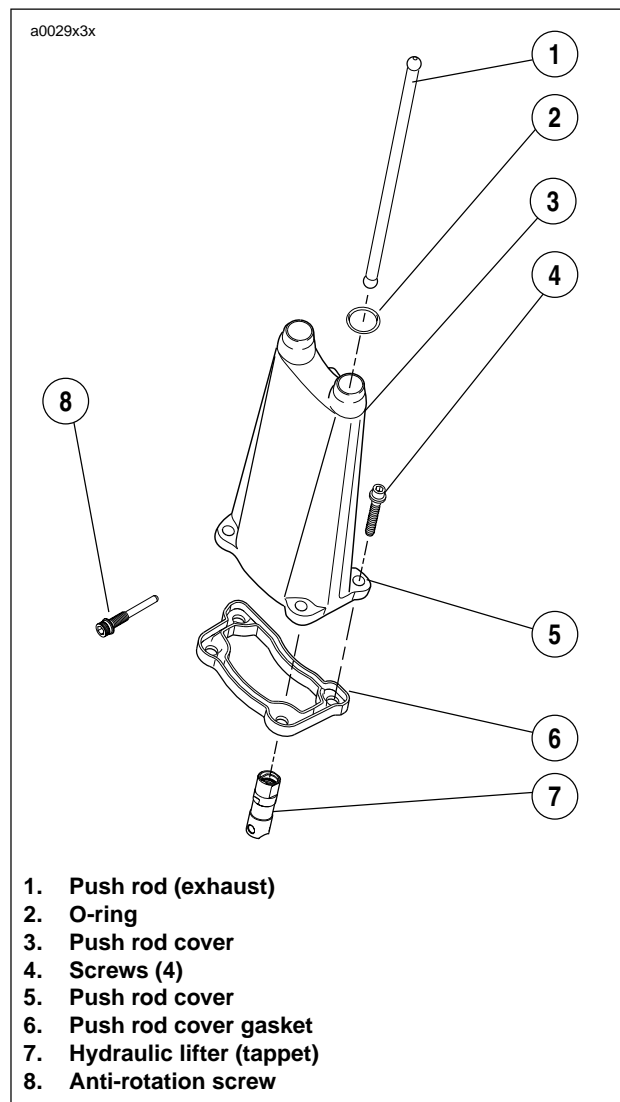


Figure 3-102. Valve Lifter Service

GENERAL

Read the complete gearcase section carefully before you begin any service work.

For the gearcase components to operate at their optimum, all components must be properly fitted and matched. Changing one component can affect many others. It is important to know and understand all inspection procedures and how components interact.

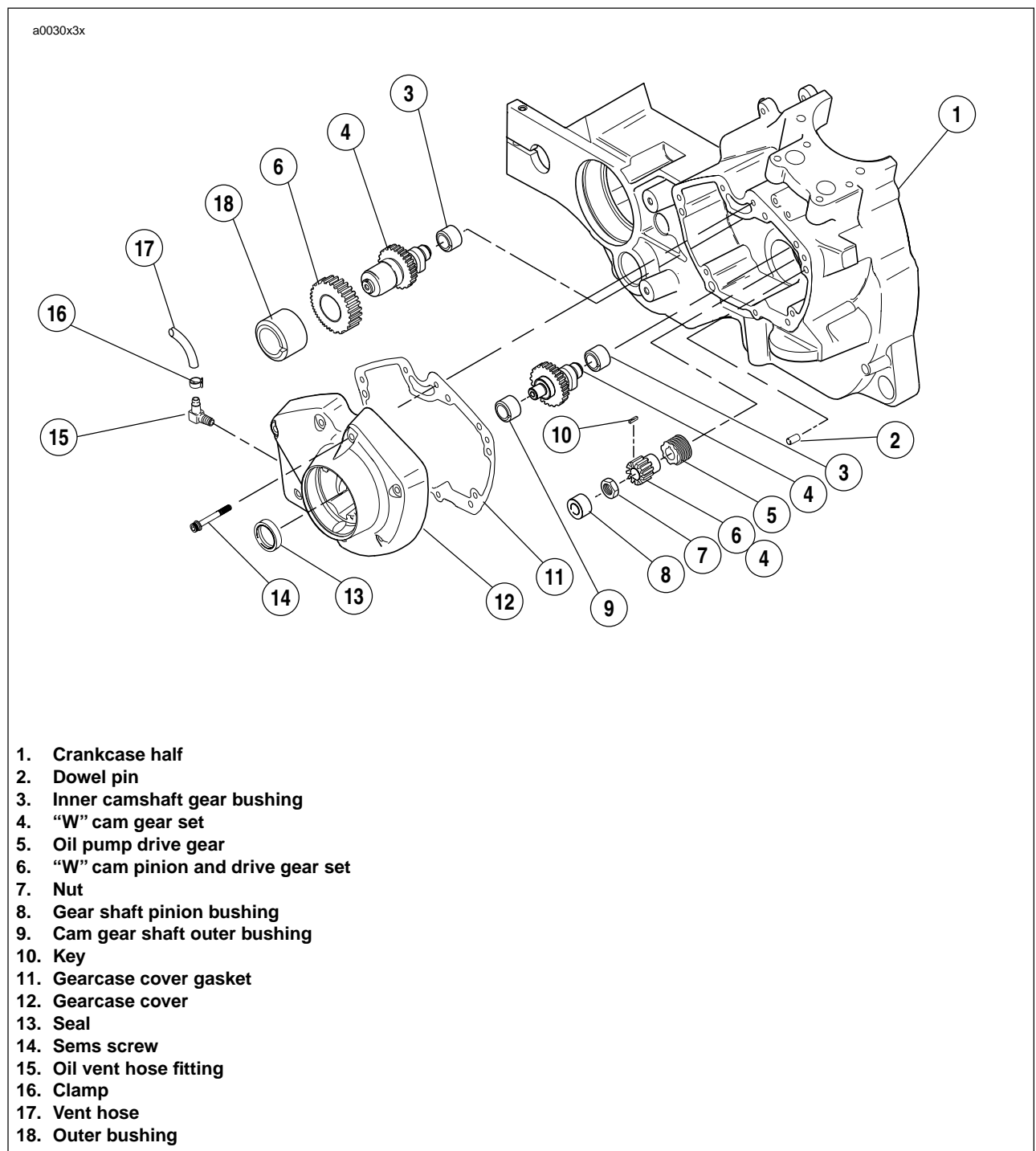


Figure 3-103. Gearcase Cover & Cam Assembly

REMOVAL/DISASSEMBLY

WARNING

Compressed air can pierce the skin and flying debris from compressed air could cause serious eye injury. Wear safety glasses when working with compressed air. Never use your hand to check for air leaks or to determine air flow rates. (00061a)

1. See Figure 3-103. Thoroughly clean area around gearcase cover and tappets. Blow loose dirt from crankcase with compressed air.
2. Remove any parts that will interfere with gearcase disassembly.
3. See 3.5 CYLINDER HEAD. Remove push rods.
4. See 3.14 HYDRAULIC LIFTERS. Remove hydraulic lifters.
5. Check for minimum cam gear end play. Record readings.
6. See 7.8 IGNITION MODULE AND CAM POSITION SENSOR. Remove cam position sensor and rotor from gearcase cover.
7. Place a pan under gearcase to collect oil. Remove cover screws. Carefully remove gearcase cover. Discard old gasket.

NOTE

If cover does not come loose on removal of screws, tap lightly with a plastic hammer. Never pry cover off.

8. Remove cam gears.

NOTE

Nut is secured by Loctite Threadlocker 271 (red) on the nut threads.

9. Remove nut. Slide pinion gear and oil pump drive gear off pinion shaft.

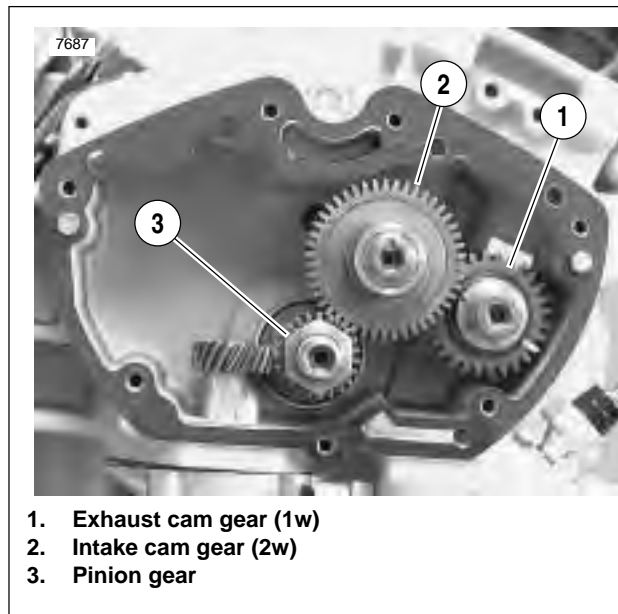
CLEANING AND INSPECTION

1. Thoroughly clean gearcase compartment, gearcase cover and gears in solvent to remove oil and carbon deposits.

WARNING

Compressed air can pierce the skin and flying debris from compressed air could cause serious eye injury. Wear safety glasses when working with compressed air. Never use your hand to check for air leaks or to determine air flow rates. (00061a)

2. Blow out all cover oil passages and bushings with compressed air.
3. Clean old gasket material from gearcase and cover faces with cleaning solvent.



1. Exhaust cam gear (1w)
2. Intake cam gear (2w)
3. Pinion gear

Figure 3-104. Cam and Pinion Gear Color Code Location and Timing Mark Indexing

NOTE

Prior to changing any cam gears, check gear shaft fit within corresponding bushings. Worn bushings can cause excessive backlash.

Bushing Inspection

1. See Figure 3-103. Bushings are press fit in crankcase and gearcase cover. Inspect each bushing against its corresponding cam gear shaft or pinion gear shaft. See Table 3-29.

NOTE

If Service Wear Limits are exceeded, replace crankcase set and/or gearcase cover as required.

Table 3-29. Gear Shaft Specifications

GEAR SHAFT	CORRECT CLEARANCE	SERVICE WEAR LIMIT
Cam	0.0007-0.0022 in. (0.0178-0.0559 mm)	0.003 in. (0.076 mm)
Pinion	0.0023-0.0043 in. (0.0584-0.1092 mm)	0.0050 in. (0.1270 mm)

ASSEMBLY/INSTALLATION

1. See [Figure 3-105](#). Install oil pump drive gear (6) and pinion gear (3) on pinion shaft (1).
 - a. Install shaft key (5) into pinion shaft slot.
 - b. Slide oil pump drive gear (6) over pinion shaft (1). Drive gear must align with shaft key.
 - c. Align keyway (4) in ID of pinion gear with shaft key.
 - d. Slide pinion gear (3) over shaft key (5) and against oil pump drive gear (6).
2. See [Figure 3-106](#). Install nut.
 - a. Clean threads on pinion shaft and nut.
 - b. Install CRANKSHAFT LOCKING TOOL (Part No. HD-43984) to gearcase with "Side B" facing out, over pinion shaft, with two screws.
 - c. Apply several drops of Loctite Threadlocker 271 (red) to last few threads of nut.
 - d. Install nut to pinion shaft. Tighten nut to 19-21 ft-lbs (26-29 Nm) plus an additional 15° to 17° rotation.
3. See [Figure 3-103](#). Liberally apply engine oil to bushings, shafts, and gears. Install all cam gears into bushings of right crankcase half, properly aligning timing marks of cam gears and pinion gear.

NOTE

Because of the larger diameter additional gear (which meshes with the pinion gear) on the outboard end of the cam, the exhaust cam gear must be installed before the intake cam gear is installed.

4. See [Figure 3-103](#). Install a **new** seal and **new** dry gear cover gasket on crankcase.

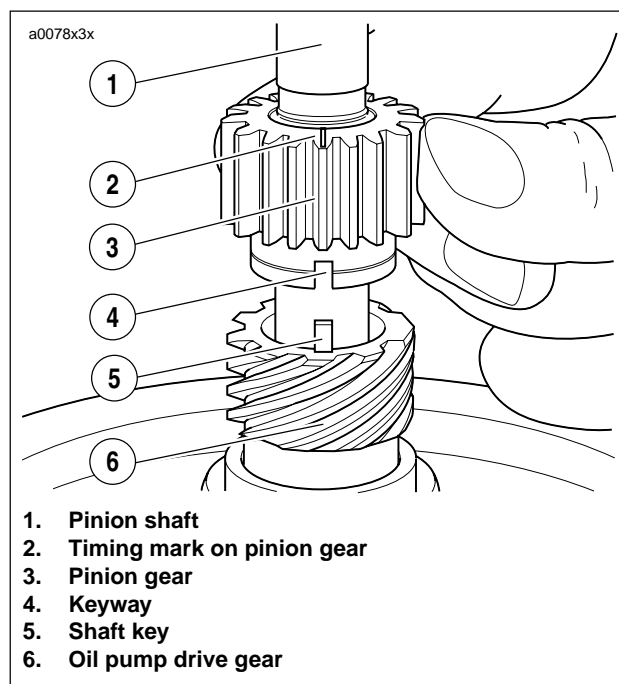


Figure 3-105. Aligning Pinion Gear

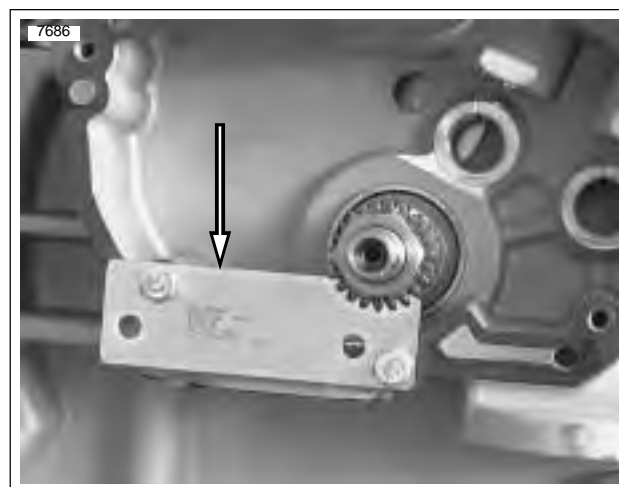


Figure 3-106. Crankshaft Locking Tool (HD-43984)

5. See [Figure 3-107](#). Install gearcase cover over all gears and onto right crankcase half. Secure cover to crankcase half with 7 socket head screws. Tighten screws evenly to 80-110 **in-lbs** (9-12 Nm). Use torque sequence as shown.
6. See [Figure 3-108](#). Check cam gear end play for each cam gear as follows:
 - a. Turn engine over until lobe of cam gear being checked is pointing toward its respective tappet guide hole.
 - b. Gently pry the cam gear toward the gearcase cover using a flat blade screwdriver.
 - c. Measure gap between bushing (in crankcase half) and cam gear shaft thrust face (shoulder) using a feeler gauge. This is cam gear end play.
 - d. Compare cam gear end play measurements with the SERVICE WEAR LIMITS. Make repairs as required if end play does not meet specifications.
7. Install hydraulic lifters and push rods. See [3.14 HYDRAULIC LIFTERS](#).
8. Install cam position sensor and rotor in gearcase cover. [7.8 IGNITION MODULE AND CAM POSITION SENSOR](#).
9. Install any components removed to gain access to gearcase (i.e. exhaust system components, air cleaner, etc.).

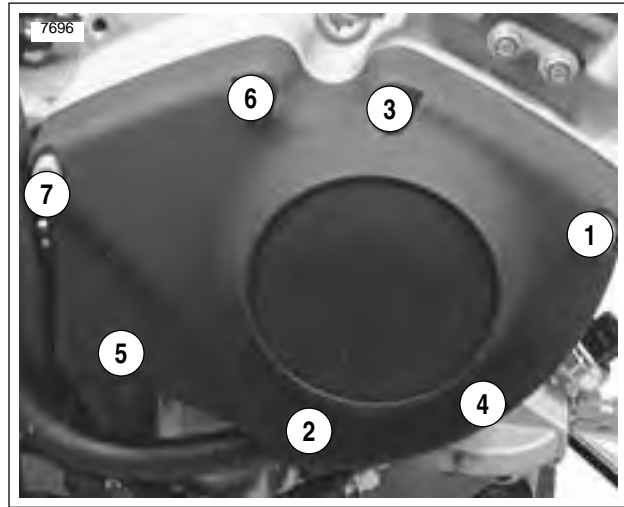


Figure 3-107. Gearcase Cover Mounting Screw Torque Sequence



Figure 3-108. Checking Cam Gear End Play

GENERAL

IMPORTANT NOTE

If engine is removed from chassis, do not lay engine on primary side. Placing engine on primary side will damage clutch cable end fitting. If fitting is damaged, clutch cable must be replaced.

Remove engine from chassis to repair pinion shaft bearing or sprocket shaft bearing. See [3.3 STRIPPING MOTORCYCLE FOR ENGINE SERVICE](#).

It is recommended procedure to overhaul engine if removed. This includes inspecting and repairing cylinder head, cylinder, gearcase and transmission.

ADJUSTMENT/TESTING

Flywheel End Play

Before completely disassembling crankcases, check flywheel end play.

1. After engine has been removed from chassis, securely fasten it to a stand or workbench.
2. Remove gearcase cover. See [3.15 GEARCASE COVER AND CAM GEARS](#).
3. See [Figure 3-109](#). Attach a dial indicator to gear side crankcase with indicator stem on end of gearshaft.
4. To obtain an accurate flywheel end play reading, preload sprocket shaft bearings. Create a suitable tool by welding two handles to an old engine sprocket nut. Install the nut and sprocket. Tighten to 190-210 ft-lbs (258-285 Nm).
5. Check flywheel end play.
 - a. Rotate and **push** on sprocket shaft while reading dial indicator.
 - b. Then rotate and **pull** on sprocket shaft while reading dial indicator.
 - c. Replace bearing inner shim if difference (end play) in indicator readings is not 0.001-0.005 in. (0.025-0.127 mm). Choose shim from [Table 3-30](#).

NOTE

Use a thinner shim for less end play; use a thicker shim for more end play.

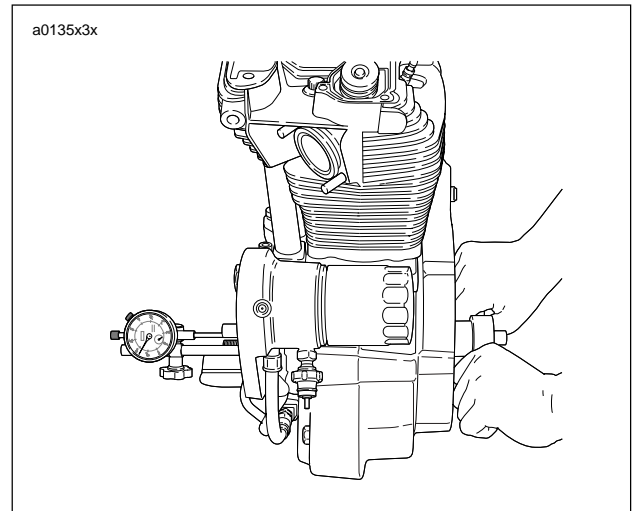


Figure 3-109. Checking Flywheel End Play

Table 3-30. Flywheel End Play Shims

PART NUMBER	THICKNESS	
	IN.	MM
9155	0.0975-0.0985	2.4765-2.5019
9142	0.0995 - 0.1005	2.5273-2.5527
9143	0.1015-0.1025	2.5781-2.6035
9144	0.1035 - 0.1045	2.6289-2.6543
9145	0.1055 - 0.1065	2.6797-2.7051
9146	0.1075 - 0.1085	2.7305-2.7559
9147	0.1095 - 0.1105	2.7813-2.8067
9148	0.1115 - 0.1125	2.8321-2.8575
9149	0.1135 - 0.1145	2.8829-2.9083

DISASSEMBLY

Crankcase Halves

1. Remove cylinder head. See 3.5 CYLINDER HEAD.

IMPORTANT NOTE

After removing cylinder, install plastic or rubber hose over cylinder studs. Lifting or moving crankcase by grasping studs will cause cylinder stud damage.

2. Remove cylinder and piston. See 3.6 CYLINDER AND PISTON.

3. Remove oil pump. See 3.12 OIL PUMP.
4. Remove gearcase components. See 3.15 GEARCASE COVER AND CAM GEARS.
5. Remove primary cover and primary drive/clutch components. See 6.2 PRIMARY CHAIN.
6. Remove starter motor. See 5.7 STARTER.
7. See Figure 3-110. Remove screws and rear engine mount bolts securing crankcase halves together.
8. Tap crankcase with plastic mallet to loosen and separate the halves.

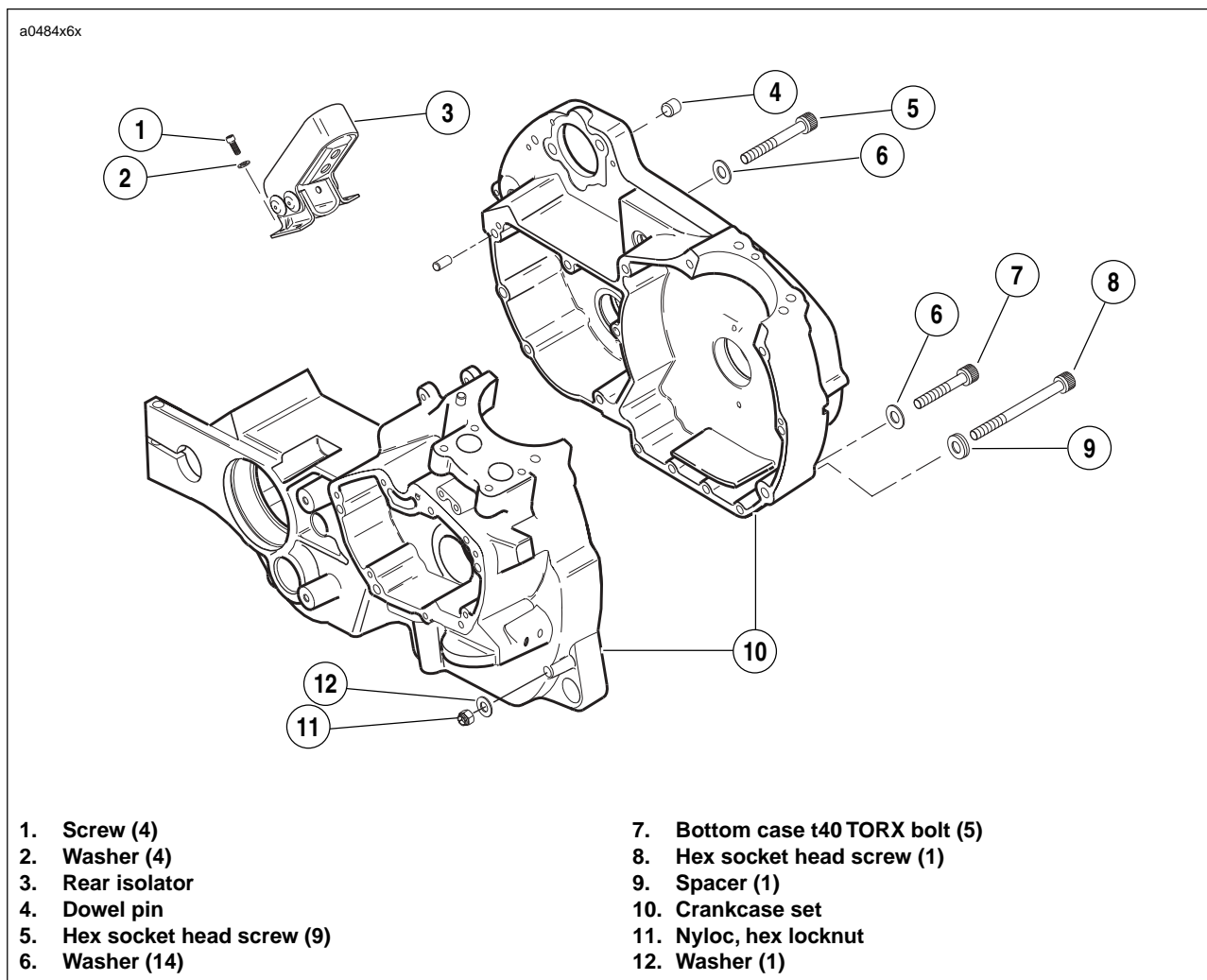


Figure 3-110. Crankcase Hardware

WARNING

When using a press, be sure setup is stable and wear proper eye protection. Flying parts could result in death or serious injury. (00467b)

- See Figure 3-111. Mount the left crankcase half and flywheel assembly on a press table, supporting crankcase on parallel bars. Press on end of sprocket shaft with arbor press until flywheel assembly is free from crankcase half. Do not drive flywheel assembly from crankcase half as flywheels may be knocked out of alignment.

NOTE

See Figure 3-112. If it is necessary to remove either the pinion shaft bearing or sprocket shaft bearing, proceed as follows:

- Gearshaft bearing will remain on flywheel pinion shaft. Remove retaining ring, and bearing may be slipped off pinion shaft.

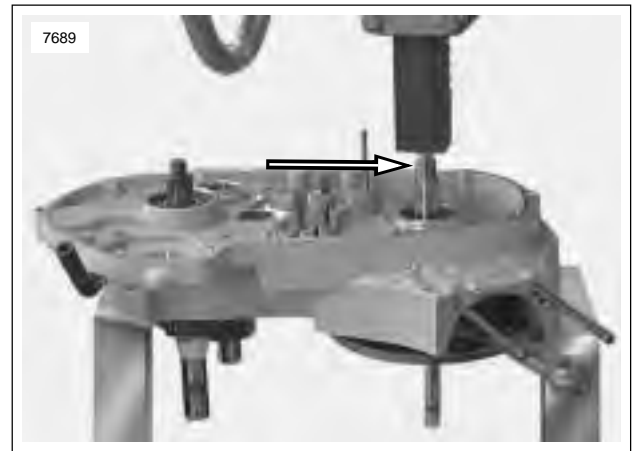


Figure 3-111. Pressing On End Of Sprocket Shaft To Remove Flywheel Assembly From Crankcase

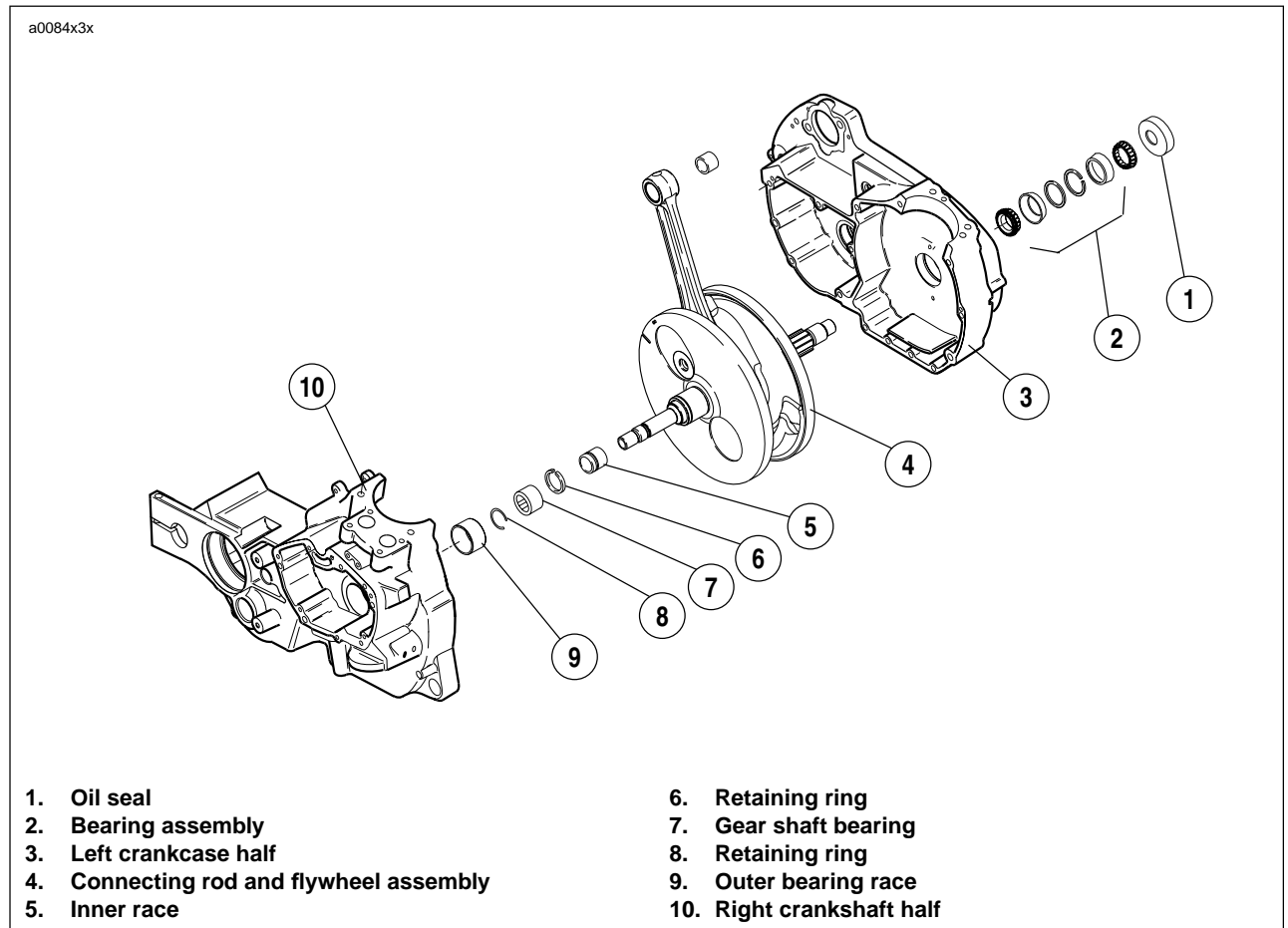


Figure 3-112. Crankcase and Flywheel Assembly

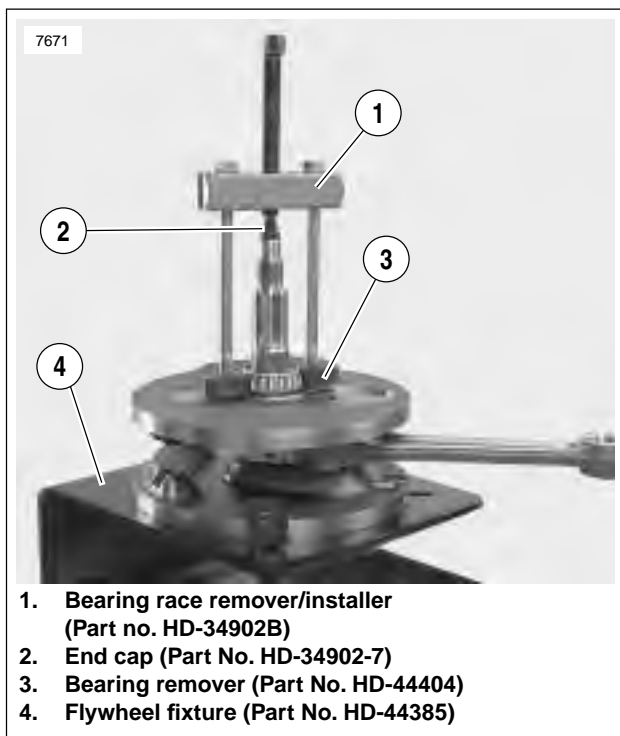


Figure 3-113. Removing Sprocket Shaft Roller Bearing

11. See [Figure 3-113](#). Place flywheel assembly in FLY-WHEEL SUPPORT FIXTURE (Part No. HD-44385). Pull sprocket shaft bearing with SPROCKET SHAFT INNER TIMKIN BEARING REMOVER (Part No. HD-44404) and BEARING RACE REMOVER/INSTALLER (Part No. HD-34902B).

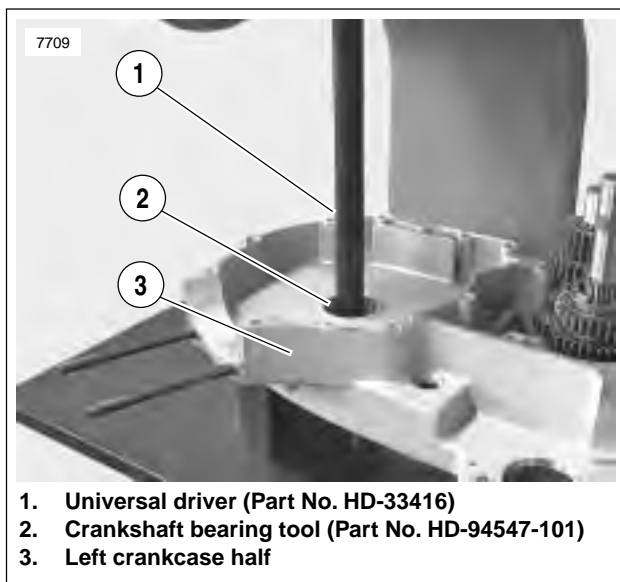


Figure 3-114. Sprocket Outer Shaft Race Removal

12. See [Figure 3-114](#). Use CRANKSHAFT BEARING TOOL (Part No. HD-94547-101) to remove sprocket shaft outer races.

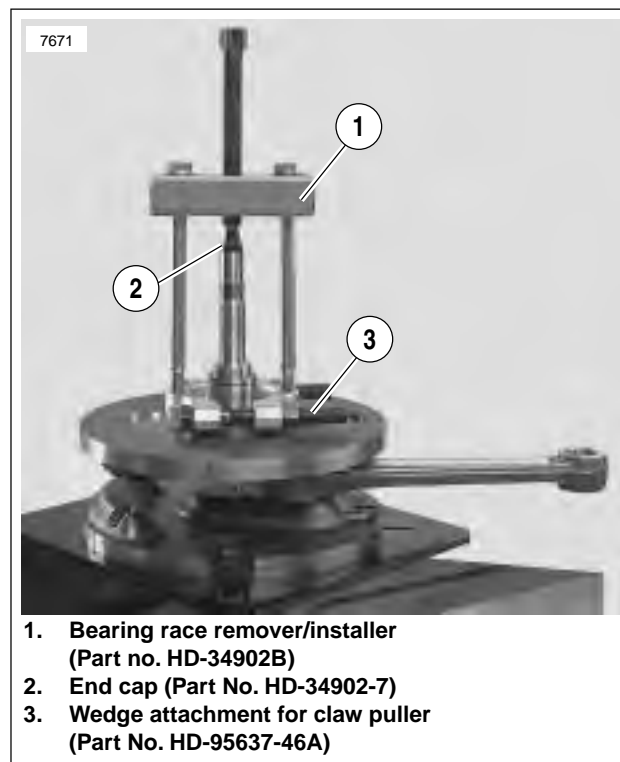


Figure 3-115. Pulling Pinion Shaft Inner Race

13. See [Figure 3-115](#). To remove pinion shaft inner race, use WEDGE ATTACHMENT for CLAW PULLER (Part No. HD-95637-46A) with BEARING RACE REMOVER/INSTALLER (Part No. HD-34902B) and END CAP (Part No. HD-34902-7). Apply heat to race to aid removal. Four sizes of pinion bearings are available. Pinion bearing selection at the factory, during engine rebuild, or replacement of crankcase set or flywheel assembly is based on the largest measured outside diameter (OD) of the inner race and the smallest measured inside diameter (ID) of the outer race (crankcase bushing). A running clearance of 0.0002-0.0008 in. (0.0051-0.0203 mm) is established during crankcase set or flywheel assembly replacement and engine rebuild.
14. See [Figure 3-116](#). Installed inner races are identified at the factory as shown.
15. See [Table 3-32](#). Outer races are identified at the factory as shown.

NOTE

The different sizes of crankcase sets and flywheel assemblies will not have separate part numbers. That is, a replacement crankcase set may have a class 1, 2 or 3 pinion outer race. Replacement flywheel assemblies will have either a class A or B inner race.

16. See [Figure 3-118](#). Pinion bearings are identified as shown.

BEARING SELECTION

Select bearings using the identification information given for inner and outer races and bearings. See [Table 3-36](#).

NOTE

If either inner or outer race show wear, measure both races to confirm correct bearing fit.

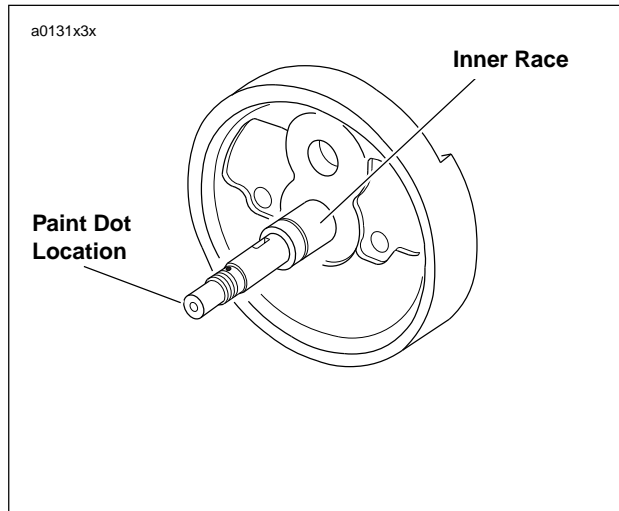


Figure 3-116. Factory Inner Race Paint Dot Location
(See [Table 3-32](#) for Identification)

Table 3-31. Paint Dot Specifications

RACE OD	CLASS	IDENTIFICATION*
1.2498-1.2500 in. (31.7449-31.7500 mm)	A	White
1.2496-1.2498 in. (31.7398-31.7449 mm)	B	Green
SERVICE WEAR LIMIT: 1.2492 in. (31.7297 mm)		

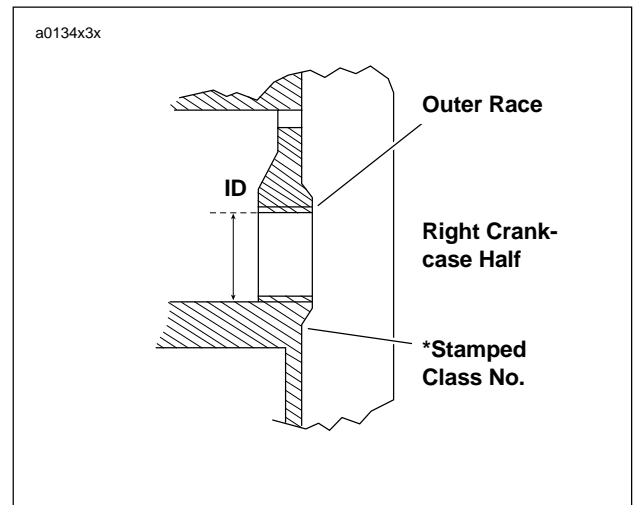


Figure 3-117. Factory Outer Race Sizes
(See [Table 3-33](#) for Identification)

Table 3-32. Stamp Specifications

RACE ID	CLASS NO.	STAMPED IDENTIFICATION*
1.5646-1.5648 in. (39.7408-39.7459 mm)	1	1
1.5648-1.5650 in. (39.7459-39.7510 mm)	2	2
1.5650-1.5652 in. (39.7510-39.7561 mm)	3	3
SERVICE WEAR LIMIT: 1.5672 in. (39.8069 mm)		

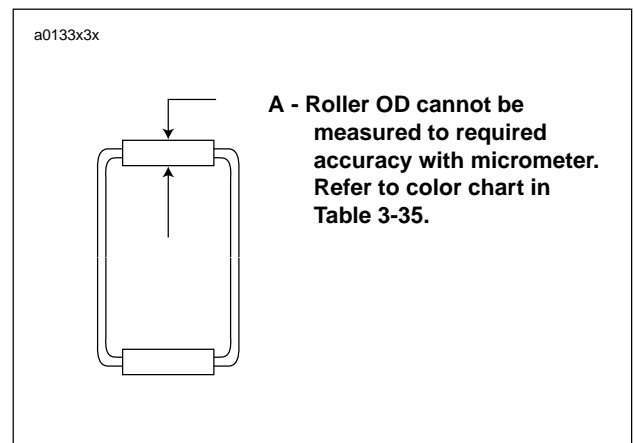


Figure 3-118. Bearing Identification

Table 3-33. Roller Specifications

ROLLER OD (*A)	IDENTIFICATION*
Largest	Red Blue
Smallest	White (Grey) Green

1. Use a dial bore gauge to measure and record ID of outer race. Take four measurements on ID where bearing rollers ride.
 - a. If the largest measurement is larger than 1.5672 in. (39.8069 mm) or the required lapping to remove wear marks would enlarge bore beyond 1.5672 in., continue at Step 5.
 - b. If largest measurement is 1.5672 in. (39.8069 mm) or less, cover the cam bearings with masking tape to prevent debris from entering bearings. Assemble crankcase halves.

NOTE

The next step requires lapping the outer race. To keep sprocket shaft and pinion shaft bearings aligned the lap must be supported by an adaptor or pilot in the left crankcase half.

2. See **LAPPING ENGINE MAIN BEARING RACES**. Lap race until all wear marks are removed.
3. Measure and record ID of race at four places.
4. Check measurements against these specifications in **Table 3-34. Outer Pinion Race Service Wear Limits**.
 - a. If lapping increased bore ID to larger than 1.5672 in. (39.8069 mm), go to Step 5.
 - b. If roundness or taper do not meet specifications, continue lapping until specifications are met.
 - c. If all specifications are met, continue at Step 7 to remove and size inner race.
5. Press the outer race from the right crankcase. Press **new** outer race into crankcase flush with inside edge of cast-in insert.

See **Figure 3-119**. Dimensions are shown for fabrication of tools used in pressing the outer race into or out of crankcase.
6. See **LAPPING ENGINE MAIN BEARING RACES**. The **new** outer race must be lapped slightly to true and align with left case bearing and to meet the following specifications.

Table 3-34. Outer Pinion Race Service Wear Limits

	in.	mm
Largest ID measured	1.5672	39.8
Roundness of ID	within 0.0002	0.0051
Taper	within 0.0002	0.0051

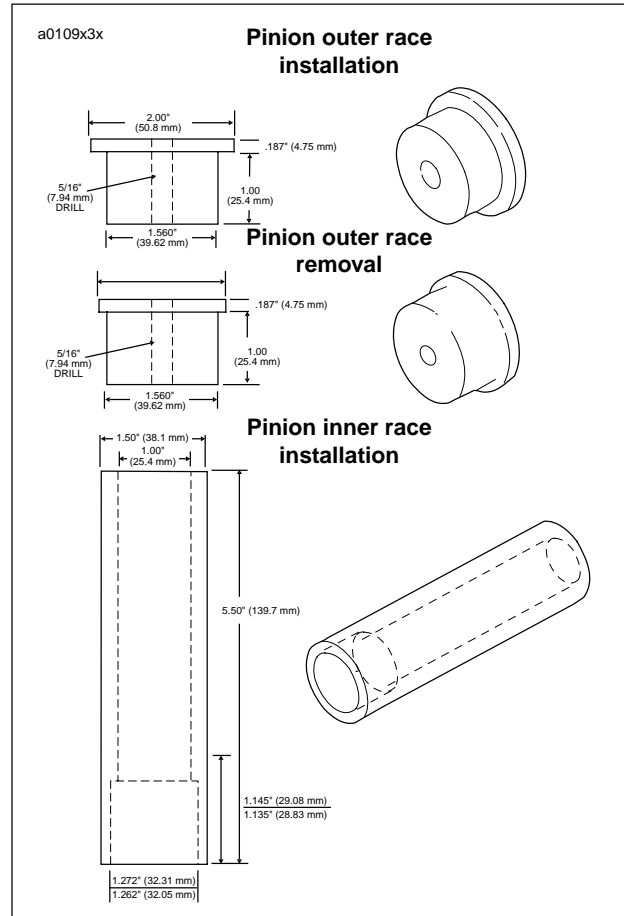


Figure 3-119. Pinion Shaft Bearing Tools

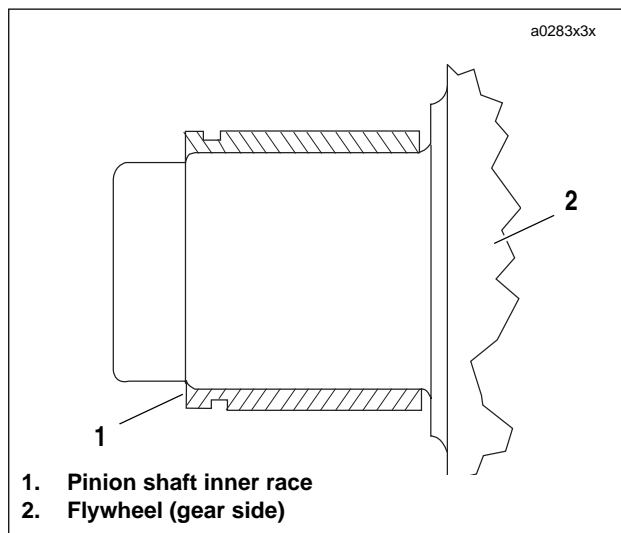


Figure 3-120. Inner Race Location

7. See [Figure 3-120](#). Pull inner race from pinion shaft using WEDGE ATTACHMENT for CLAW PULLER (Part No. HD-95637-46A) with BEARING RACE REMOVER/INSTALLER (Part No. HD-34902B) and END CAP (Part No. HD-34902-7). Apply heat to race to aid removal.
8. Press **new** inner race on pinion shaft as shown. The **new** inner race must be ground by a competent machinist to OD dimension range for the finished lapped ID of the outer race. Refer to [Table 3-35](#). The finished inner race must meet these specifications. For necessary dimensions for constructing a press-on tool see [Figure 3-119](#). When the tool bottoms against the flywheel, correct inner race location is automatically established.

Table 3-35. Pinion Inner Race Fitment Specifications

Roundness	within 0.0002 in. (0.0051 mm)
Taper	within 0.0002 in. (0.0051 mm)
Surface finish	16 RMS

NOTE

Always use the smallest outer race ID measurement and the largest OD inner race measurement when selecting bearings.

9. The following example illustrates how to determine the required inner race OD.
 - a. See [Table 3-36](#). For example purposes, suppose the smallest outer race ID measurement is 1.5651 in. (39.754 mm). This requires an inner race OD range of 1.2496-1.2504 in. (31.740 - 31.760 mm).
 - b. Grind inner race. Measure OD at four places. Check that specifications in Step 8 are met.
 - c. For example purposes, suppose the largest inner race OD measurement after grinding is 1.2499 in. (31.747 mm) OD.
 - d. With a 1.5651 in. (39.754 mm) ID outer race and a 1.2499 in. (31.747 mm) OD inner race, a blue bearing is required.

NOTES

- *Have machinist grind inner race to center or middle of required OD range in [Table 3-36](#). This will prevent grinding outer race undersize and gives a more easily achieved tolerance range.*
- *If you are unable to perform this operation, Harley-Davidson Motor Company provides a flywheel refurbishing program as outlined in Tech Tip #38.*
- *Always use the smallest outer race ID measurement and the largest OD inner race measurement when selecting bearings.*

Table 3-36. Pinion Shaft Bearing Selection

FACTORY STAMPED NUMBER	OUTER RACE ID	BEARING SIZE AS IDENTIFIED BY COLOR CODING											
	over 1.5672 in. 39.807 mm	Service Wear Limit Exceeded – Replace Outer Race and Resize											
	1.5670-1.5672 in. 39.802-39.807 mm												Red
	1.5668-1.5670 in. 39.797-39.802 mm											Red	Blue
	1.5666-1.5668 in. 39.792-39.797 mm									Red	Blue	White-Gray	
	1.5664-1.5666 in. 39.787-39.792 mm								Red	Blue	White-Gray	Green	
	1.5662-1.5664 in. 39.781-39.787 mm							Red	Blue	White-Gray	Green		
	1.5660-1.5662 in. 39.776-39.781 mm						Red	Blue	White-Gray	Green			
	1.5658-1.5660 in. 39.771-39.776 mm				Red	Blue	White-Gray	Green					
	1.5656-1.5658 in. 39.766-39.771 mm			Red	Blue	White-Gray	Green						
	1.5654-1.5656 in. 39.761-39.766 mm			Red	Blue	White-Gray	Green						
	1.5652-1.5654 in. 39.756-39.761 mm		Red	Blue	White-Gray	Green							
3	1.5650-1.5652 in. 39.751-39.756 mm	Red	Blue	White-Gray	Green								
2	1.5648-1.5650 in. 39.746-39.751 mm	Blue	White-Gray	Green									
1	1.5646-1.5648 in. 39.741-39.746 mm	White-Gray	Green										
INNER RACE OD (In)	1.2496 - 1.2498 in.	1.2498 - 1.2500 in.	1.2500 - 1.2502 in.	1.2500 - 1.2504 in.	1.2504 - 1.2506 in.	1.2506 - 1.2508 in.	1.2508 - 1.2510 in.	1.2510 - 1.2512 in.	1.2512 - 1.2514 in.	1.2514 - 1.2516 in.	1.2516 - 1.2518 in.	1.2516 - 1.2518 in.	1.2516 - 1.2518 in.
	31.740 - 31.745 mm	31.745 - 31.750 mm	31.750 - 31.755 mm	31.755 - 31.760 mm	31.760 - 31.765 mm	31.765 - 31.770 mm	31.770 - 31.775 mm	31.775 - 31.780 mm	31.780 - 31.786 mm	31.786 - 31.791 mm	31.791 - 31.796 mm	31.791 - 31.796 mm	31.791 - 31.796 mm
FACTORY COLOR CODE	Green	White											

Lapping Engine Main Bearing Races

1. Secure right and left crankcase halves with three crankcase stud bolts (top center and bottom left and right). The sprocket shaft bearing outer races and large spacer must be installed in left crankcase.

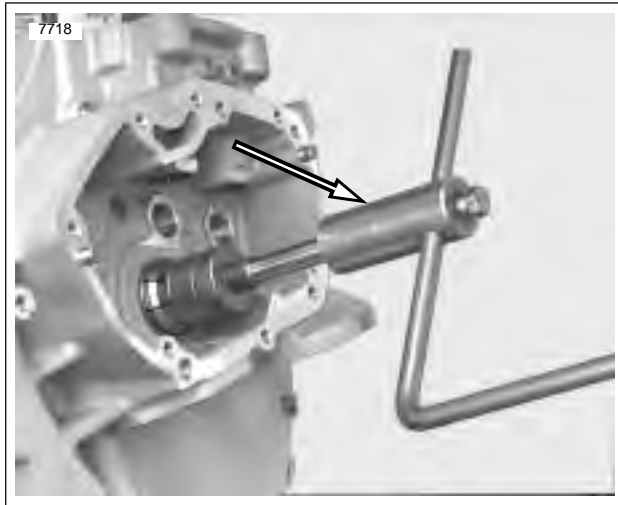


Figure 3-121. Lapping Pinion Shaft Main Bearing Using Crankcase Main Bearing Lapping Tool (Part No. HD-96710-40B)

2. See [Figure 3-121](#). Obtain CRANKCASE MAIN BEARING LAPPING TOOL (Part No. HD-96710-40B). Assemble CRANKCASE MAIN BEARING LAP (Part No. HD-96718-87) to lapping handle. Assemble guide sleeve to sprocket shaft bearing bushing. Sleeves, for use with tapered bearing, are assembled to case with bearings and small spacer collar. Finger-tighten the sleeve parts.
3. Insert lap shaft with arbor assembled through pinion bearing bushing and into guide sleeve. Tighten arbor expansion collars using a length of 0.156 in. (3.962 mm) rod as spanner until arbor begins to drag. Do not adjust arbor snug in bushing or bushing will “bell,” a condition where hole is larger at ends than it is in the center.
4. Withdraw arbor far enough to coat lightly with 220 grit lapping compound. Do not apply a heavy coat. Reposition lap in bushing and turn handle at moderate hand speed. Work lap back and forth in bushing, as it is revolved, to avoid grooving and tapering.

At frequent intervals, remove lap from crankcase, wash and inspect bushing. Lapping is completed when entire bushing surface has a dull, satin finish rather than a glossy, smooth appearance. If necessary, flush off lap in cleaning solvent, air dry and apply fresh, light coat of fine lapping compound.

Checking Connecting Rod Side Play

1. See [Figure 3-122](#). Check connecting rod side play with a thickness gauge as shown.

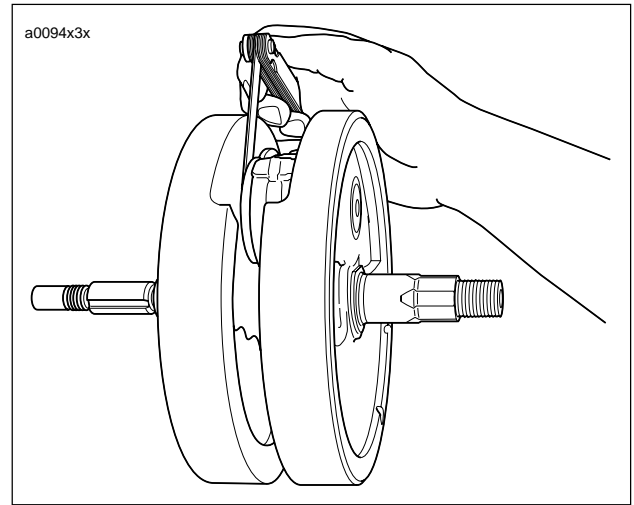


Figure 3-122. Checking Connecting Rod Side Play

2. If side play measurement is greater than service wear limit of 0.030 in. (0.762 mm), replace flywheel/connecting rod assembly.

PISTON JET

Removal

1. See [Figure 3-123](#). Remove two TORX screws from piston jet assembly to remove piston jet from right crankcase.
2. Remove piston jet gasket from right crankcase.

Installation

IMPORTANT NOTE

If a gasket is missing, distorted, pinched or otherwise damaged will result in either oil leakage or low oil pressure.

NOTE

Gasket is part of the piston jet assembly. Gasket not sold separately.

1. Install **new** piston oil jet assembly in right crankcase.
2. Apply Loctite 222 (purple) to threads of TORX screws.
3. With the jet pointed upward, install TORX screws to secure piston jet to crankcase. Tighten screws to 25-35 **in-lbs** (2.8-4.0 Nm).

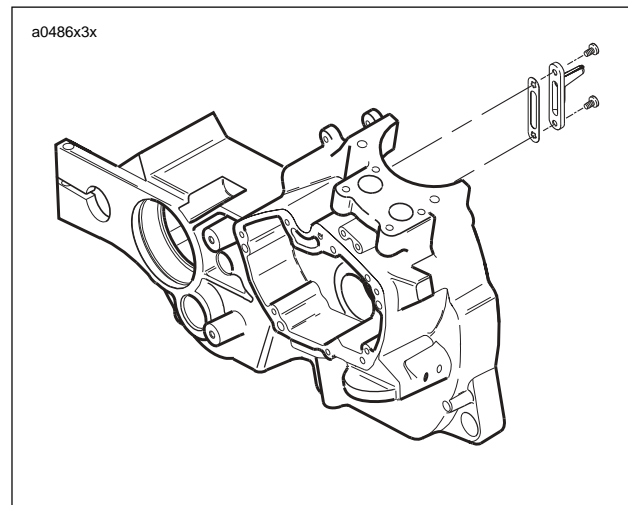


Figure 3-123. Piston Oil Jet Assembly

ASSEMBLY

Crankcase Halves

Lubricate all parts with Harley-Davidson 20W50 engine oil, and proceed as follows:

1. See [Figure 3-124](#). Install **new** snap ring to crankcase bore (if bearings were replaced).
 - a. Place the crankcase half on a flat surface with the outboard side facing up.
 - b. Obtain the TIMKEN SNAP RING REMOVER/INSTALLER (HD-44069).
 - c. With the gap in the snap ring being the 12 o'clock position, place the two claws so that the slotted sides engage the inside edge of the snap ring at the 10 and 2 o'clock positions.
 - d. Using a 9/64 inch allen head bit, tighten the screws to fix the position of the claws on the snap ring.
 - e. Inserting the tips of a large retaining ring pliers (Snap-On PR-56A) into one hole in each claw, compress the snap ring and install in groove of crankcase bore.
 - f. Verify that the gap in the snap ring is centered below the oil hole at the top of the ring groove. Move snap ring if not properly centered.
 - g. Loosen allen head screws and remove claws from snap ring.

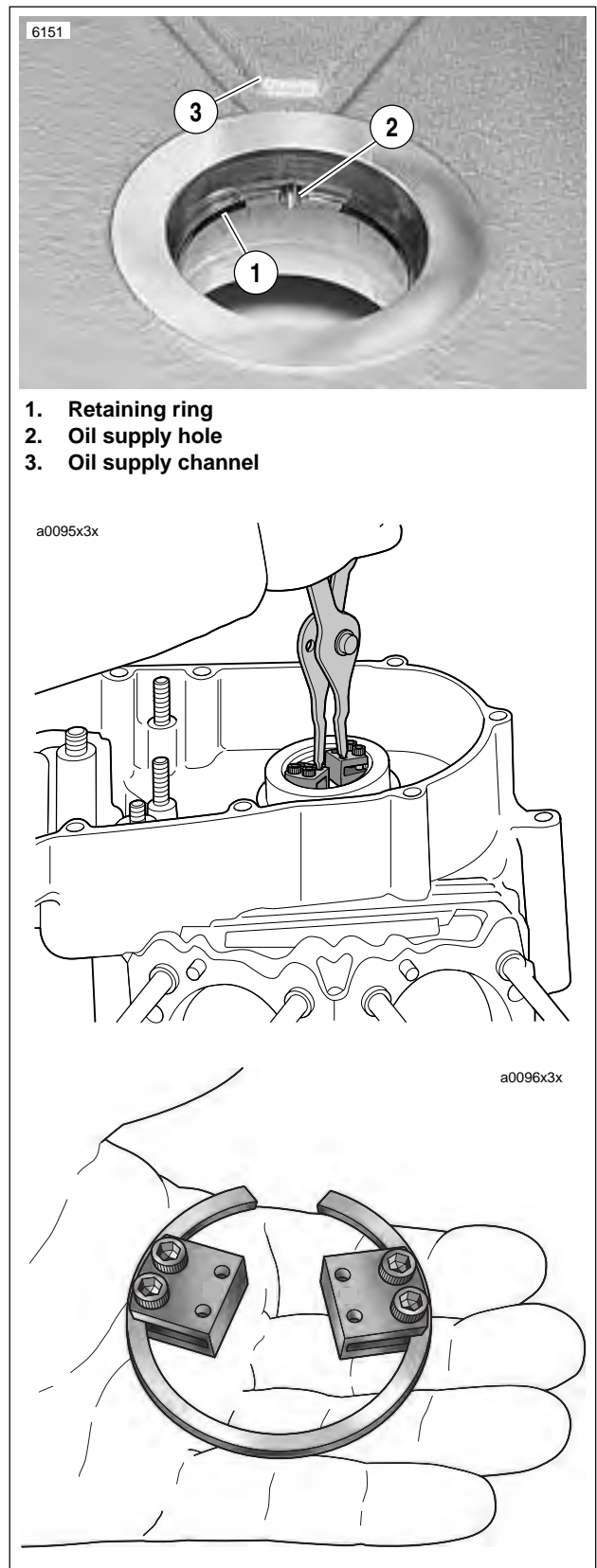


Figure 3-124. Snap Ring Installation Using Retaining Ring Remover/Installer (Part No. HD-44069)

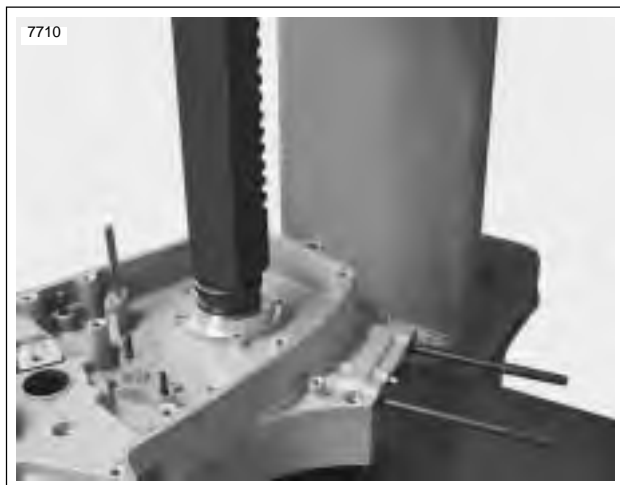


Figure 3-125. Left Outer Bearing Race Installation

NOTE

See [Figure 3-125](#). Use *SPROCKET SHAFT BEARING OUTER RACE INSTALLATION TOOL (Part No. HD-39458)* to install left and right outer races of sprocket shaft tapered roller bearings into left crankcase half. Always install left outer race prior to installing right outer race because the installer base is usable only when you follow this sequence of race installation.

2. Insert "SPORTSTER" end of installer base into inboard side of left crankcase half bearing bore until base contacts installed retaining ring.
3. Position left outer race over bearing bore on outboard side of left crankcase half.
4. Insert shaft of installer plug through left outer race and into installer base. Press race into bore until firmly seated against retaining ring.



Figure 3-126. Right Outer Bearing Race Installation

5. See [Figure 3-126](#). Insert "SPORTSTER" end of installer base into outboard side of left crankcase half bearing bore until base contacts outboard surface of installed left outer race.
6. Position right outer race over bearing bore on inboard side of left crankcase half.
7. See [Figure 3-126](#). Insert shaft of installer plug through right outer race and into installer base. Press race into bore until firmly seated against retaining ring.

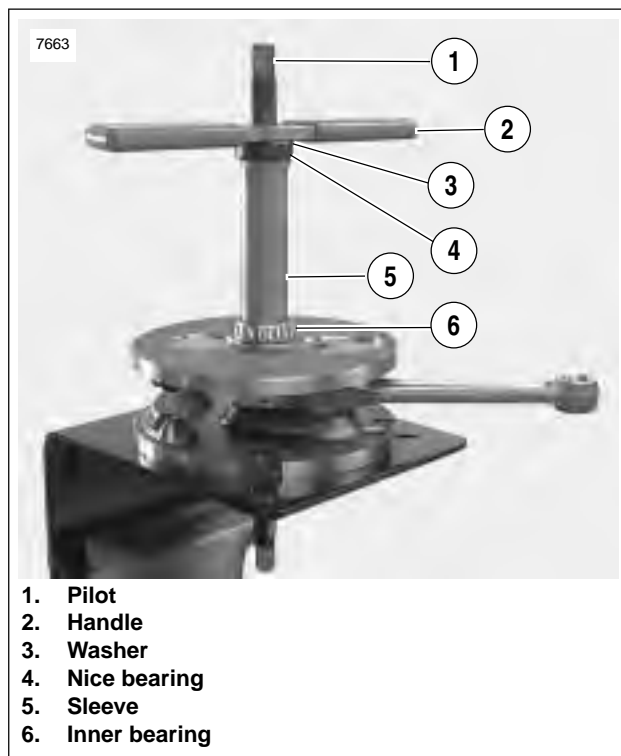


Figure 3-127. Inner Bearing Installation

NOTE

See [Figure 3-127](#). Use *SPROCKET SHAFT BEARING/SEAL INSTALLATION TOOL* (Part No. HD-42579) to install sprocket shaft tapered roller bearings and seal.

8. See [Figure 3-127](#). Install inner bearing.
 - a. Place **new** bearing, small end upward, over end of sprocket shaft.
 - b. Thread pilot onto sprocket shaft until pilot bottoms on sprocket shaft shoulder.
 - c. Sparingly apply graphite lubricant to threads of pilot shaft to ensure smooth operation.
 - d. Slide sleeve over pilot until sleeve contacts inner bearing race. Install Nice bearing, washer and handle on top of sleeve.
 - e. Rotate handle clockwise until bearing contacts flywheel shoulder. Remove tool from sprocket shaft.

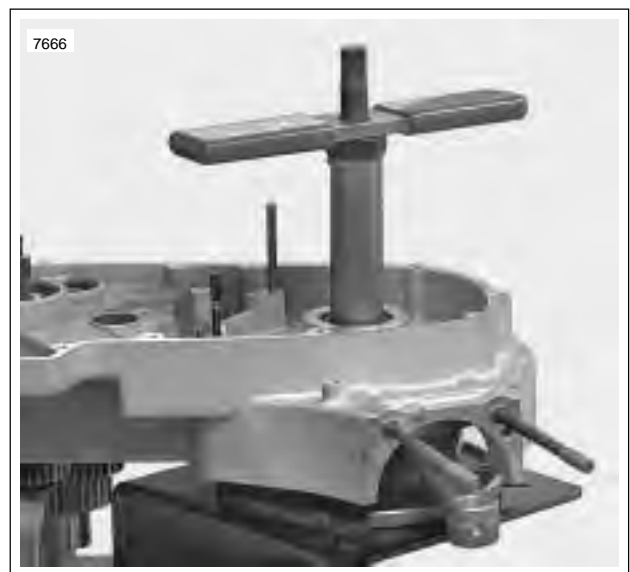
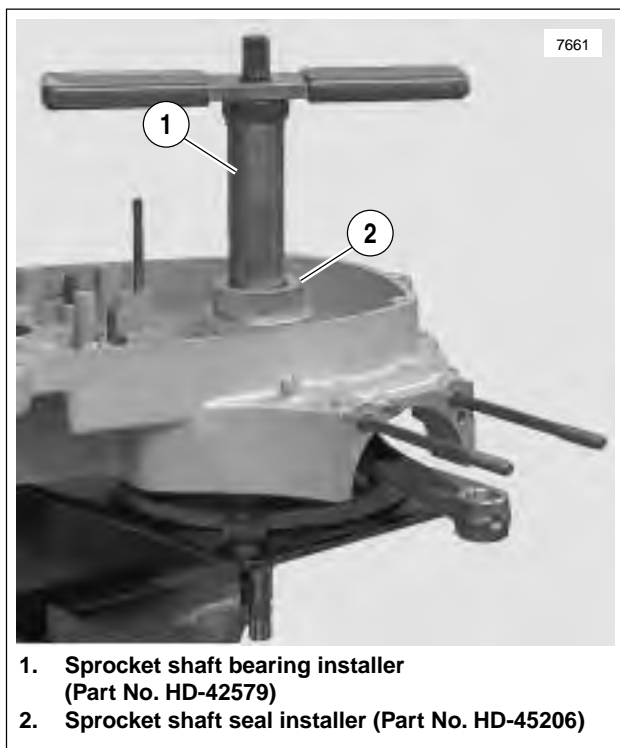


Figure 3-128. Installing Flywheel Spacer and Outer Bearing

9. See [Figure 3-128](#). Install shim and outer bearing.
 - a. Carefully place crankcase half over sprocket shaft so that it rests flat on inner bearing.
 - b. Slide **new** inner spacer over sprocket shaft until it contacts inner bearing race.
 - c. Place **new** outer bearing, small end downward, over sprocket shaft.
 - d. Assemble Sprocket Shaft Bearing/Seal Installation Tool (Part No. HD-42579) onto sprocket shaft. Follow procedure in Step 8.
 - e. Rotate handle clockwise until bearing firmly contacts inner spacer. Inner and outer bearings must be tight against inner spacer for correct bearing clearance. Remove tool from sprocket shaft.
 - f. Spin crankcase half to verify that flywheel assembly is free.



1. Sprocket shaft bearing installer (Part No. HD-42579)
2. Sprocket shaft seal installer (Part No. HD-45206)

Figure 3-129. Installing Sprocket Shaft Oil Seal/Spacer

10. See [Figure 3-129](#). Install **new** spacer in seal ID. With the open (lipped) side facing outward, center seal/spacer assembly over bearing bore.

IMPORTANT NOTE

Do not remove the spacer after installation or the new seal will have to be discarded and the procedure repeated.

11. Install bearing seal and spacer.
 - a. Center seal/spacer driver over seal, so that the sleeve (smaller OD) seats between seal wall and garter spring.
 - b. Assemble SPROCKET SHAFT BEARING INSTALLER (1) (Part No. HD-42579) and SPROCKET SHAFT SEAL INSTALLER (Part No. HD-45206) onto sprocket shaft. Follow procedure in Step 8.
 - c. Rotate handle clockwise until the spacer makes contact with the bearing. Remove tool from sprocket shaft.

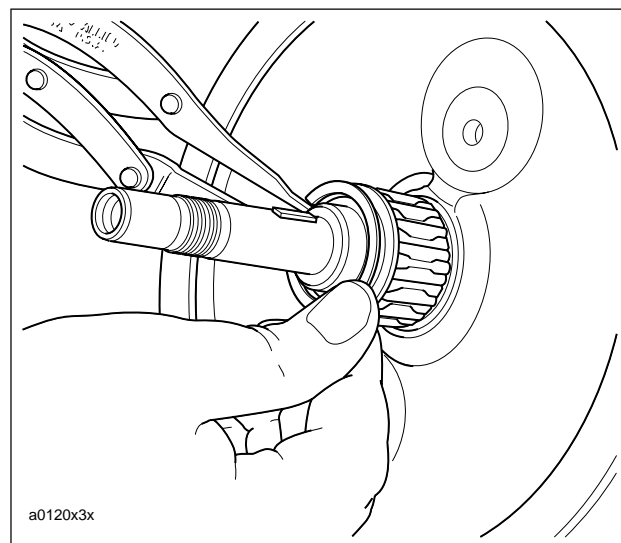


Figure 3-130. Pinion Shaft Bearing

12. See [Figure 3-130](#). Install pinion shaft bearing.
 - a. Lubricate pinion shaft bearing with engine oil.
 - b. Slip bearing on pinion shaft.
 - c. Install **new** retaining ring in groove of pinion shaft bearing inner race.
13. Install transmission. See [6.12 TRANSMISSION INSTALLATION](#).
14. Assemble crankcase halves together.
 - a. Apply a thin coat of DOW CORNING SILASTIC or 3-M 800 sealant to crankcase joint faces.
 - b. Slide pinion shaft through outer race in right crankcase.
 - c. Attach crankcase halves using hardware shown in [Figure 3-110](#).
 - d. Tighten the 5/16-18 X 3-1/2 in. fasteners to 15-19 ft-lbs (20-26 Nm).
 - e. Tighten the 5/16-18 X 2-1/2 in fasteners to 15-19 ft-lbs (20-26 Nm).
 - f. Tighten 3/8-in. fastener to 22-27 ft-lbs (30-37 Nm).

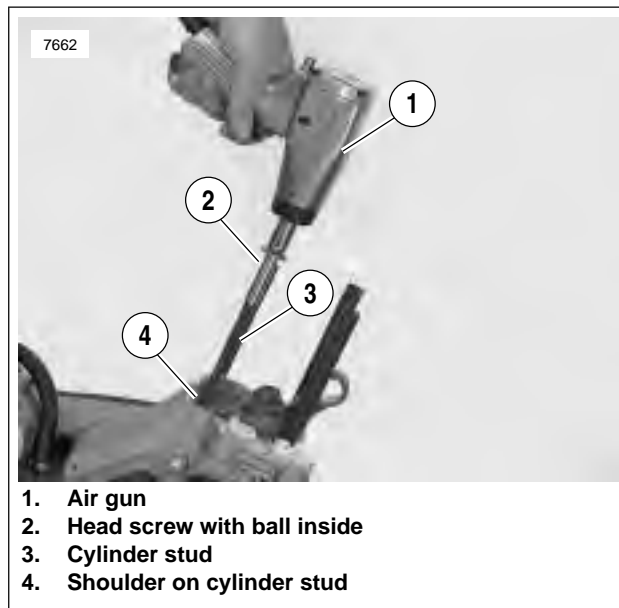


Figure 3-131. Cylinder Studs

15. See [Figure 3-131](#). Install cylinder studs.
 - a. Pack clean towels into crankcase opening.
 - b. Place a steel ball into a head screw.
 - c. The cylinder studs have a shoulder at the lower end. Place the end of the stud without the shoulder into the head screw.
 - d. Install the stud in the crankcase with the shoulder end down. Use an air gun to drive the stud until the shoulder reaches the crankcase.
 - e. Remove air gun. Use a torque wrench to tighten stud to 10-20 ft-lbs (14-27 Nm).

16. Install piston and cylinder. See [3.6 CYLINDER AND PISTON](#).
17. Install oil pump. See [3.12 OIL PUMP](#).
18. See [3.15 GEARCASE COVER AND CAM GEARS](#). Install cam gears, gearcase cover, lifter guides and lifters.
19. Install cylinder head. See [3.5 CYLINDER HEAD](#).
20. Install starter. See [5.7 STARTER](#).
21. Install shift linkage.
22. Install all primary drive components. This includes engine sprocket, primary chain, complete clutch assembly, engine sprocket nut and mainshaft nut. See [6.4 PRIMARY DRIVE/CLUTCH](#).
23. Install primary cover. See [6.2 PRIMARY CHAIN](#).

NOTE

Be sure to refill transmission to proper level with fresh lubricant. See [1.10 TRANSMISSION/PRIMARY FLUID](#).

24. See [3.4 ENGINE INSTALLATION](#) and perform the applicable steps.

NOTES

[Table Of Contents](#)

FUEL SYSTEM

4

SUBJECT	PAGE NO.
4.1 Specifications	4-1
4.2 Fuel Tank Cover/Fuel Tank	4-5
4.3 Air Cleaner	4-13
4.4 Carburetor	4-14
4.5 Auto-Enrichener	4-21
4.6 Throttle Position Sensor	4-23
4.7 Evaporative Emissions Control System	4-24

Table 4-1. Fuel Tank Capacity

	U.S.	METRIC
Total (including reserve)	2.8 gallons	10.6 liters
Reserve	0.55 gallons	2.08 liters

Table 4-2. Carburetor Jet Sizes

Main jet	166
Slow jet	42

Table 4-3. Carburetor Adjustments

Engine idle speed (regular)	1200 RPM
Engine idle speed (fast)	2000 RPM

TORQUE TABLE

ITEM	TORQUE		NOTES
Auto-enrichener	13-23 in-lbs	2-3 Nm	Page 4-22
Battery cables to terminals	72-96 in-lbs	8-11 Nm	Page 4-6, 4-15
Enrichener stay plate	13-23 in-lbs	2-3 Nm	Page 4-15
Fuel cap flange to fuel tank	20-22 in-lbs	2-3 Nm	Page 4-12
Fuel tank to T-shaped bracket	72-96 in-lbs	8-11 Nm	Page 4-6
Fuel valve to fuel tank	19-21 in-lbs	2-2.3 Nm	Page 4-9
Tank cover to T-shaped bracket	30-36 in-lbs	3-4 Nm	Page 4-6
Vent tube fitting	40-60 in-lbs	5-7 Nm	Page 4-12

Table 4-4. Fuel System Troubleshooting

OVERFLOW TROUBLESHOOTING	
Check for: <ol style="list-style-type: none"> 1. Restricted fuel tank vent system. 2. Loose float bowl screws. 3. Damaged float bowl o-ring. 4. Damaged or leaking float assembly. 5. Particle contamination in fuel inlet fitting cavity. 6. Worn or dirty inlet valve or seat. 7. Improper fuel level in float bowl. 	Remedy: <ol style="list-style-type: none"> 1. Correct restricted hose. Replace vapor vent valve. 2. Tighten screws. 3. Replace o-ring. 4. Replace float assembly. 5. Clean and clear cavity and fuel supply tract. 6. Clean or replace valve and clean seat. 7. Adjust float tab for correct fuel level.
POOR IDLING	
Check for: <ol style="list-style-type: none"> 1. Idle speed improperly adjusted. 2. Inlet system air leak (faster idling). 3. Loose low speed jet. 4. Contaminated or plugged low speed system. 5. Enrichener valve not seated or leaking. 	Remedy: <ol style="list-style-type: none"> 1. Adjust operating idle speed. 2. Correct as required. 3. Tighten jet. 4. Clean, clear and correct as required. 5. Adjust, clean or replace.
POOR FUEL ECONOMY	
Check for: <ol style="list-style-type: none"> 1. Enrichener valve not seated or leaking. 2. Dirty air cleaner filter element. 3. Restricted fuel tank vent system. 4. High speed riding style. 5. Idle speed improperly adjusted. 6. Loose jets. 7. Fuel level too high. 8. Plugged or restricted bowl vent. 9. Worn or damaged needle or needle jet. 10. Vacuum piston assembly malfunction. 11. Plugged air jets or passages. 	Remedy: <ol style="list-style-type: none"> 1. Clean or replace. 2. Replace as required. 3. Correct restricted hose. Replace vapor vent valve. 4. Modify riding habits. 5. Adjust operating idle speed. 6. Tighten jets. 7. Adjust float tab for correct fuel level. 8. Clean and clear passages. 9. Replace needle or needle jet. 10. See Table 4-5. 11. Clean, clear and correct as required.
POOR ACCELERATION	
Check for: <ol style="list-style-type: none"> 1. Throttle cables misaligned. 2. Inlet system air leak. 3. Restricted fuel tank vent system. 4. Restricted fuel supply passages. 5. Plugged bowl vent or overflow. 6. Enrichener valve not seated or leaking. 7. Worn or damaged needle or needle jet. 8. Vacuum piston malfunction. 9. Plugged jets or passages. 10. Fuel level too low. 	Remedy: <ol style="list-style-type: none"> 1. Adjust throttle cables. 2. Correct as required. 3. Correct restricted hose. Replace vapor vent valve. 4. Correct and clear restriction. 5. Clean and clear passages. 6. Adjust, clean or replace. 7. Replace assembly. 8. See Table 4-5. 9. Clean and clear as required. 10. Adjust float tab for correct fuel level.

Table 4-4. Fuel System Troubleshooting

HARD STARTING	
Check for:	Remedy:
<ol style="list-style-type: none"> 1. Enrichener system plugged, not properly functioning or improperly operated. 2. Inlet system air leak. 3. Restricted fuel supply. 4. Fuel overflow. 5. Plugged slow jet or passages. 	<ol style="list-style-type: none"> 1. Clean, adjust or replace. 2. Correct as required. 3. Correct fuel supply or passages. 4. See OVERFLOW TROUBLESHOOTING above. 5. Clean, clear and correct as required.
POOR PERFORMANCE ON ROAD	
Check for:	Remedy:
<ol style="list-style-type: none"> 1. Idle speed improperly adjusted. 2. Inlet system air leak. 3. Restricted fuel tank vent system. 4. Dirty or damaged air cleaner element. 5. Enrichener valve not seated or leaking. 6. Restricted fuel supply tract. 7. Plugged bowl vent or overflow. 8. Loose or plugged fuel and air jets or passages. 9. Worn or damaged needle or needle jet. 10. Vacuum piston assembly malfunction. 	<ol style="list-style-type: none"> 1. Adjust operating idle speed. 2. Correct as required. 3. Correct restricted hose. Replace vapor vent valve. 4. Replace. 5. Adjust, clean or replace. 6. Correct and clear restriction. 7. Clean and clear passages. 8. Clean, clear and correct as required. 9. Replace assembly. 10. Refer to Table 4-5.
POOR HIGH-SPEED PERFORMANCE	
Check for:	Remedy:
<ol style="list-style-type: none"> 1. Inlet system air leak. 2. Enrichener valve not seated or leaking. 3. Restricted fuel tank vent system. 4. Restricted fuel supply tract. 5. Dirty or damaged air cleaner element. 6. Plugged bowl, vent or overflow. 7. Worn or damaged needle or needle jet. 8. Vacuum piston assembly malfunction. 9. Loose or plugged main jets or passages. 10. Improper fuel level. 	<ol style="list-style-type: none"> 1. Clean or replace. 2. Adjust, clean or replace. 3. Correct restricted hose. Replace vapor vent valve. 4. Correct and clean restriction. 5. Replace. 6. Clean and clear passages. 7. Replace assembly. 8. Refer to Table 4-5. 9. Clean, clear and correct as required. 10. Adjust float level.

Table 4-5. Vacuum Piston Assembly Troubleshooting

PISTON DOES NOT RISE PROPERLY	
Check for: <ol style="list-style-type: none">1. Piston atmosphere vent blocked.2. Diaphragm cap loose, damaged or leaking.3. Spring binding.4. Diaphragm pinched at lip groove.5. Torn diaphragm.6. Piston binding.7. Piston vacuum passage plugged.	Remedy: <ol style="list-style-type: none">1. Clear vent.2. Tighten or replace cap.3. Correct or replace spring.4. Reposition diaphragm lip.5. Replace piston diaphragm assembly.6. Clean piston slides and body or replace piston.7. Clean and clear passage.
PISTON DOES NOT CLOSE PROPERLY	
Check for: <ol style="list-style-type: none">1. Spring damaged.2. Piston binding.3. Piston diaphragm ring dirty or damaged.	Remedy: <ol style="list-style-type: none">1. Replace spring.2. Clean piston slides and body or replace piston.3. Clean or replace piston.

REMOVAL

Fuel Tank Cover

⚠ WARNING

Stop the engine when refueling or servicing the fuel system. Do not smoke or allow open flame or sparks near gasoline. Gasoline is extremely flammable and highly explosive, which could result in death or serious injury. (00002a)

1. See Figure 4-1. Remove seat.

⚠ WARNING

To prevent accidental vehicle start-up, which could cause death or serious injury, disconnect negative (-) battery cable before proceeding. (00048a)

2. Unthread bolt and remove battery negative cable (black) from battery negative (-) terminal.
3. See Figure 4-2. At rear of fuel tank, remove flange bolt (2), with nylon washer, to release tank cover from clip nut on T-shaped mounting bracket (3).
4. Carefully cut small cable strap and pull vent tube from fitting at front of fuel cap flange.
5. Remove oil dipstick from threaded hole in frame backbone (just rear of steering head). Remove mounting ring from around threaded hole.
6. See Figure 4-2. Remove tank cover (1) and set aside.
7. Install oil dipstick back into threaded hole in frame backbone.

Fuel Tank

1. See Figure 4-5. Rotate the 3-position valve handle on the fuel valve to the fully vertical position to shut the gasoline supply to the carburetor OFF.

⚠ WARNING

With fuel tank drained, gasoline can spill from bore when supply valve is loosened or removed. Gasoline is extremely flammable and highly explosive, which could result in death or serious injury. Wipe up spilled fuel immediately and dispose of rags in a suitable manner. (00277a)

2. Turn slotted screw to loosen band clamp on outlet fitting at side of fuel valve. Pull hose from fitting.
3. See Figure 4-2. At rear of fuel tank, remove remaining two flange bolts (4) to release T-shaped mounting bracket from frame backbone.
4. Remove left side air box cover. See 4.3 AIR CLEANER.
5. See Figure 4-3. Moving to front of vehicle, pry rubber stops from weld studs on each side of frame backbone.
6. Raise rear of fuel tank and slide assembly rearward to remove from frame.

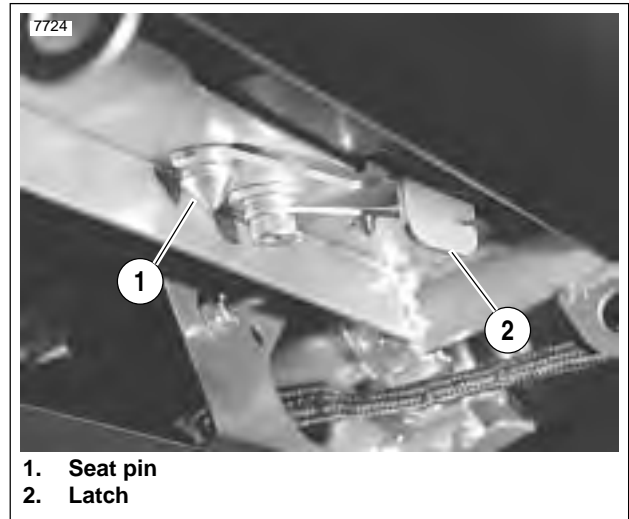


Figure 4-1. Remove Seat

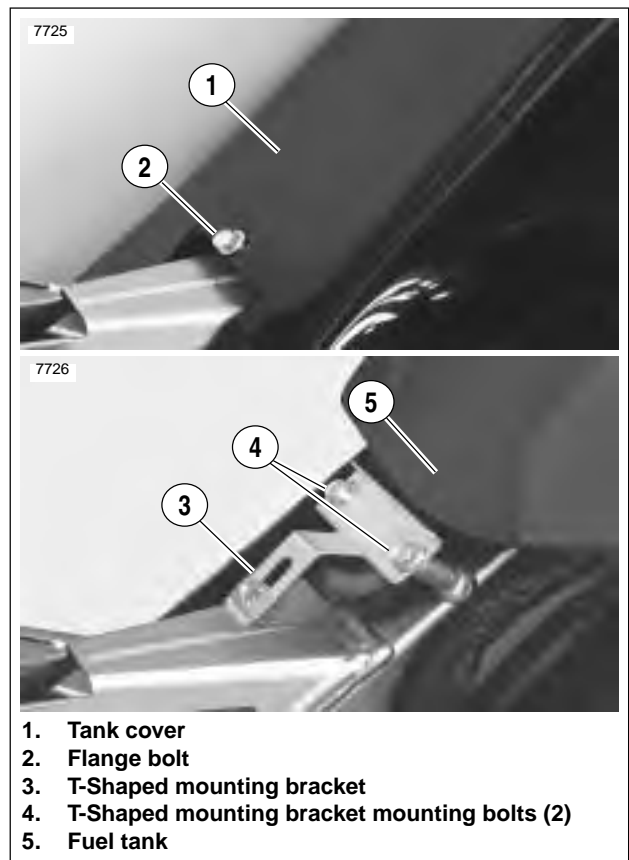


Figure 4-2. Remove Tank Cover Fuel Tank

INSTALLATION

Fuel Tank

1. Place fuel tank into position on frame backbone.
2. See [Figure 4-3](#). Standing at front of vehicle, push rubber stops (2) onto weld studs (4) on each side of frame backbone. Using a rubber mallet, tap stops until fully seated.
3. See [Figure 4-2](#). With the lipped side up, slide two flange bolts through forward holes in T-shaped mounting bracket. Pushing down on rear of tank, start flange bolts into bosses in frame backbone. Alternately tighten flange bolts to 72-96 **in-lbs** (8-11 Nm).
4. Install air box cover on left hand side. See [4.3 AIR CLEANER](#).
5. Push hose onto outlet fitting at side of fuel valve. Turn slotted screw to tighten band clamp.

Fuel Tank Cover

1. Remove oil dipstick from threaded hole in frame backbone (just rear of steering head).
2. Install tank cover.
3. See [Figure 4-2](#). At rear of fuel tank, install rear flange bolt (with nylon washer) to fasten tank cover to clip nut on T-shaped mounting bracket. Tighten flange bolt to 30-36 **in-lbs** (3-4 Nm).
4. With the lipped side up, place mounting ring over threaded hole in frame backbone. Install oil dipstick into hole.
5. Push vent tube onto nozzle of vent tube fitting. Install small cable strap to fix location. Cut any excess cable strap material.
6. Insert bolt through battery negative cable (black) into threaded hole of battery negative (-) terminal. Tighten bolt to 72-96 **in-lbs** (8-11 Nm).

WARNING

After installing seat, pull upward on front of seat to be sure it is in locked position. While riding, a loose seat can shift causing loss of control, which could result in death or serious injury. (00070a)

7. See [Figure 4-1](#). Install seat.

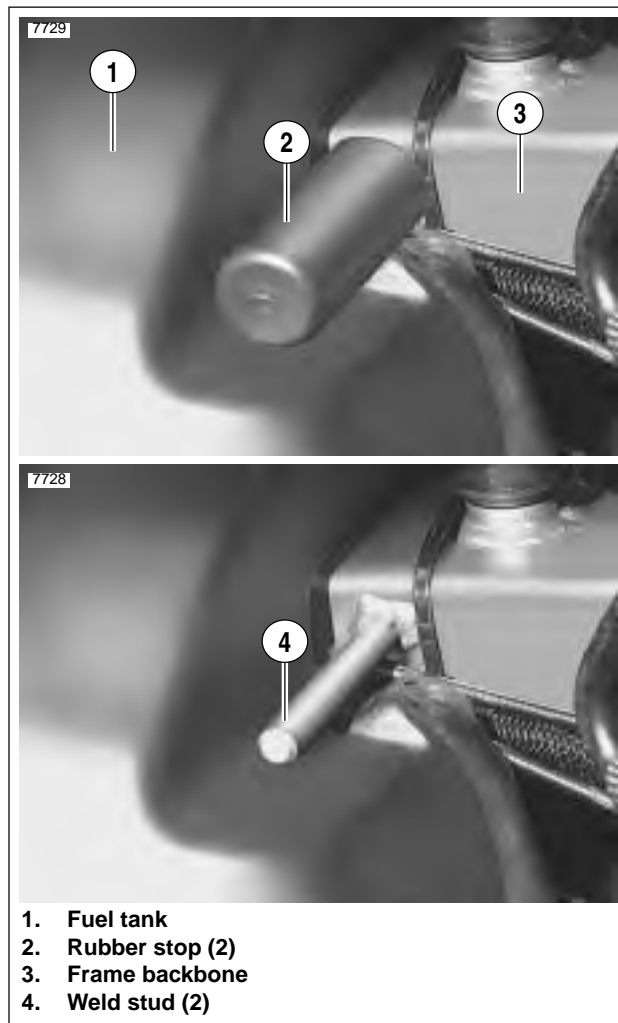


Figure 4-3. Remove Fuel Tank

FUEL CAP

Removal

1. Locate the fuel filler cap at the top of the fuel tank.
2. Insert finger into depression and lift the locking tab so that it is perpendicular to the fuel filler cap.
3. Rotate the locking tab 1/4 turn in a counter-clockwise direction until it clicks.
4. Pull locking tab to remove fuel filler cap from tank.
5. See [Figure 4-4](#). Observe the warning label at the top of the fuel tank. When refueling, keep fuel level at least one inch below bottom of fuel cap boot (1).

WARNING

Observe the warning label at the top of the tank. Avoid spills. Slowly remove filler cap. Do not fill above bottom of filler neck insert, leaving air space for fuel expansion. Secure filler cap after refueling. Gasoline is extremely flammable and highly explosive, which could result in death or serious injury. (00028a)

Installation

1. See [Figure 4-4](#). Inspect o-ring (2) at underside of fuel filler cap for cuts, tears or signs of deterioration. Replace if necessary.
2. Place fuel filler cap into tank with the depression at the front.
3. Rotate the locking tab 1/4 turn in a clockwise direction.
4. Push locking tab down, so that it is flush with the fuel filler cap.

NOTE

See [Figure 4-4](#). Locking tab should snap down tightly, but not so tight that it becomes too difficult to remove. To increase or decrease the tension required to operate the locking tab, turn the fuel filler cap over and either loosen or tighten the 10 mm nut (3).

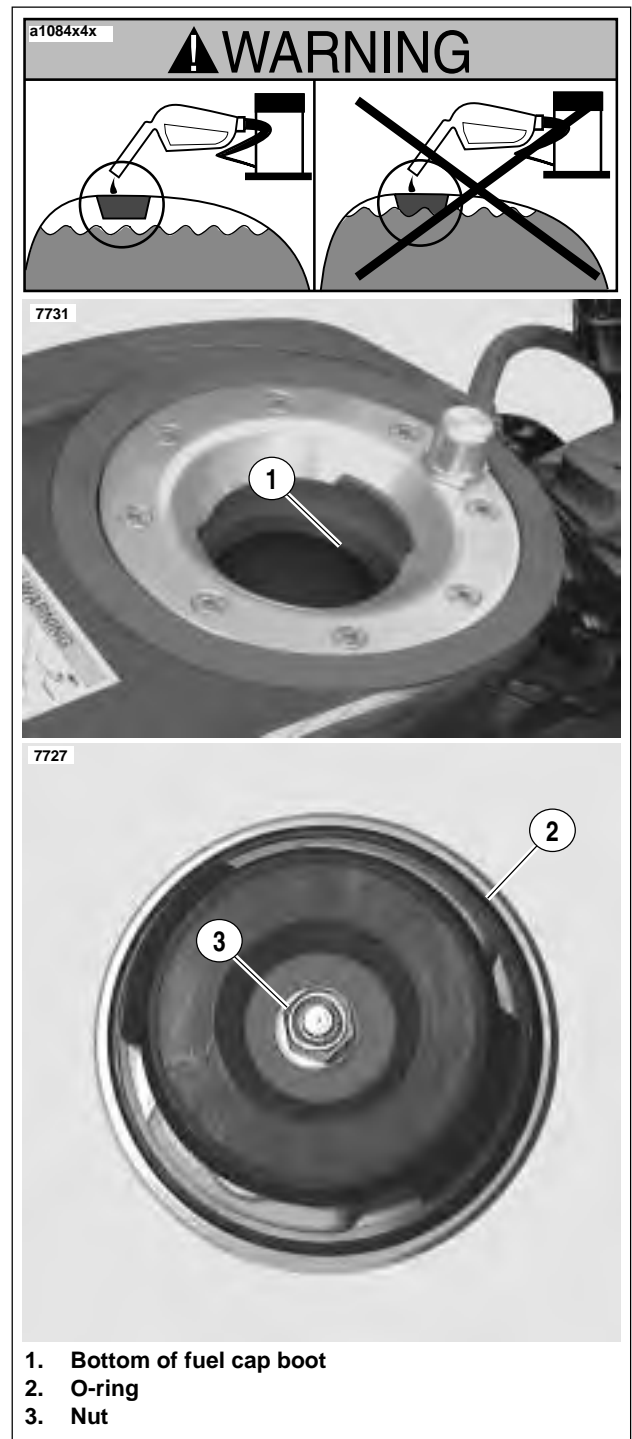


Figure 4-4. Fuel Cap

FUEL SUPPLY VALVE

Operation

See [Figure 4-5](#). The fuel supply valve is located under the fuel tank on the left side of the vehicle. The gasoline supply to the carburetor is dependent upon the position of the valve handle.

Turning the 3-position valve handle to the fully vertical position shuts the gasoline supply to the carburetor "OFF". Moving the valve handle counter-clockwise to the horizontal position turns the main fuel supply "ON". Turning the handle clockwise to the horizontal position accesses the "RES(ERVE)" supply.

⚠ WARNING

To prevent accidental flooding of the engine or surrounding area with gasoline, always turn the fuel supply valve to OFF when the engine is not running. Gasoline is extremely flammable and highly explosive, which could result in death or serious injury. (00098a)

NOTE

To maintain a reserve supply, do not operate the motorcycle with the valve in the "RES(ERVE)" position after refueling.

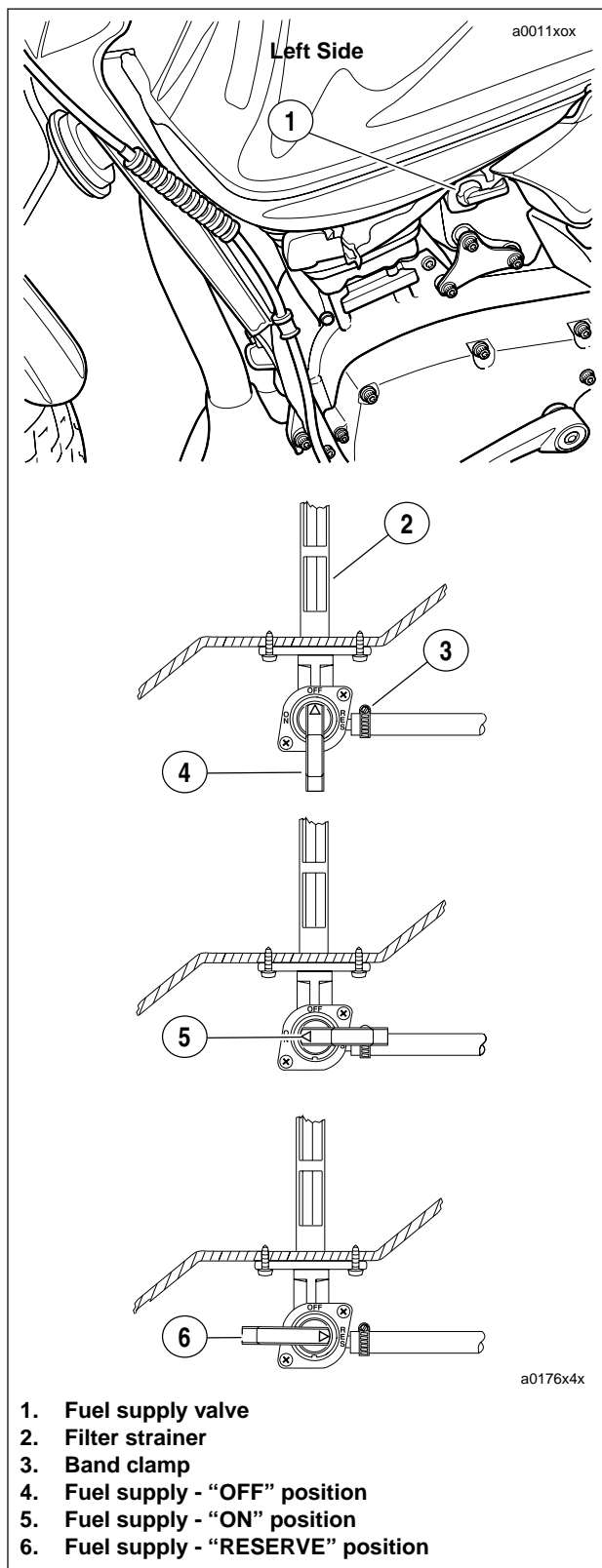


Figure 4-5. Fuel Supply Valve

Removal

NOTE

Clean or replace fuel filter strainer every 20,000 miles (32,000 km).

WARNING

Stop the engine when refueling or servicing the fuel system. Do not smoke or allow open flame or sparks near gasoline. Gasoline is extremely flammable and highly explosive, which could result in death or serious injury. (00002a)

1. Remove seat. See 2.28 SEAT.

WARNING

To prevent accidental vehicle start-up, which could cause death or serious injury, disconnect negative (-) battery cable before proceeding. (00048a)

2. Unthread bolt and remove battery negative cable (black) from battery negative (-) terminal.
3. Drain fuel tank as follows:
 - a. See Figure 4-5. Rotate handle on the fuel supply valve to the fully vertical position to shut the gasoline supply to the carburetor "OFF".
 - b. Some gasoline will drain from the outlet hose when disconnected from the fuel valve. Thoroughly wipe up any spilt fuel immediately. Dispose of rags in a suitable manner. Gasoline is extremely flammable and highly explosive. Inadequate safety precautions could result in death or serious injury.
 - c. Turn slotted screw to loosen band clamp on outlet fitting at side of fuel valve. Pull hose from fitting.
 - d. Attach length of spare hose to outlet fitting. Place free end of hose into a suitable container.
 - e. See Figure 4-5. Rotate handle of fuel supply valve to "RES(ERVE)" to start the flow of fuel.
 - f. Once the fuel tank is completely drained, rotate handle of fuel supply valve to "OFF". Remove spare hose from outlet fitting.

WARNING

With fuel tank drained, gasoline can spill from bore when supply valve is loosened or removed. Gasoline is extremely flammable and highly explosive, which could result in death or serious injury. Wipe up spilled fuel immediately and dispose of rags in a suitable manner. (00277a)

4. Remove two allen head screws from fuel valve and pull assembly from fuel tank bore.
5. Remove o-ring from flange of fuel valve assembly. Discard o-ring.
6. Carefully unthread fuel filter strainer from fuel valve assembly. Clean strainer using a suitable solvent. Discard strainer if any damage is found.

Installation

1. Carefully thread fuel filter strainer onto fuel valve assembly.
2. Install **new** o-ring into groove on flange of fuel valve assembly.
3. Insert fuel valve assembly into fuel tank bore and install two allen head screws. Alternately tighten screws to 19-21 **in-lbs** (2-2.3 Nm).
4. Push hose onto outlet fitting at side of fuel valve. Turn slotted screw to tighten band clamp.
5. Verify that handle of fuel supply valve is in the "OFF" position and fill the fuel tank.
6. Rotate handle of fuel supply valve to "ON" and carefully inspect for leaks. Return the valve to the "OFF" position when finished.
7. Insert bolt through battery negative cable (black) into threaded hole of battery negative (-) terminal. Tighten bolt to 72-96 in-lbs (8-11 Nm).

WARNING

After installing seat, pull upward on front of seat to be sure it is in locked position. While riding, a loose seat can shift causing loss of control, which could result in death or serious injury. (00070a)

8. Install seat.

ROLLOVER VALVE

NOTE

See [Figure 4-6](#). When the vehicle is upright the check ball holds the post to one side allowing hydrocarbon vapors to be released into the atmosphere or into a charcoal canister (California). When the vehicle is tipped, the check ball moves away from the post, which is spring loaded, allowing the post to seal the opening preventing loss of gasoline through the vent tube.

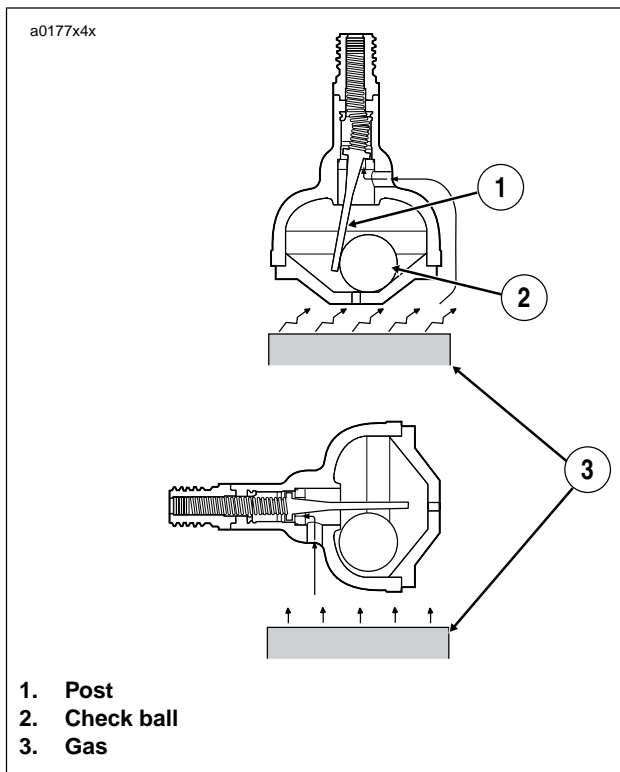


Figure 4-6. Rollover Valve

Removal

⚠ WARNING

Stop the engine when refueling or servicing the fuel system. Do not smoke or allow open flame or sparks near gasoline. Gasoline is extremely flammable and highly explosive, which could result in death or serious injury. (00002a)

1. Remove seat. Depress latch at bottom and pull seat up and back to remove. See [2.28 SEAT](#).

⚠ WARNING

To prevent accidental vehicle start-up, which could cause death or serious injury, disconnect negative (-) battery cable before proceeding. (00048a)

2. Unthread bolt and remove battery negative cable (black) from battery negative (-) terminal.
3. Drain fuel tank. See [1.20 FUEL SUPPLY VALVE AND FILTER STRAINER](#).
4. Remove fuel filler cap from tank.

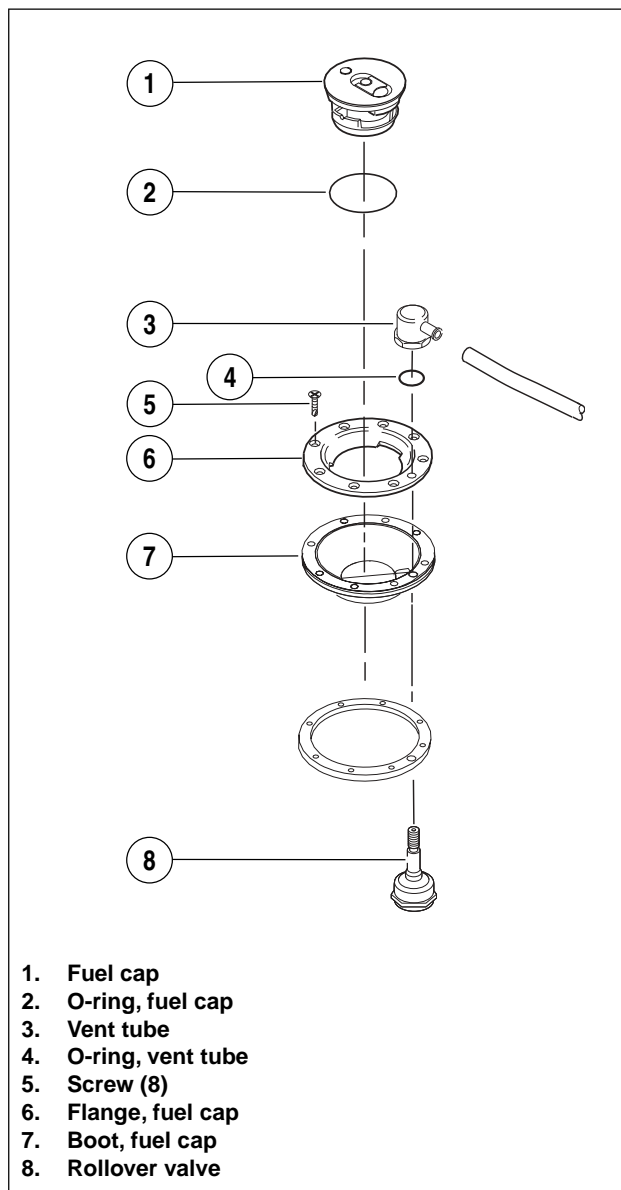


Figure 4-7. Rollover Valve And Fuel Cap Assembly

5. See [Figure 4-7](#). Carefully cut small cable strap and pull vent tube from fitting at front of fuel cap flange.
6. Alternately loosen and remove eight fuel cap flange screws in a crosswise pattern.
7. Insert fingers into filler neck and under fuel cap boot to hold bottom of rollover valve. Rotate hex on vent tube fitting in a counter-clockwise direction and remove.

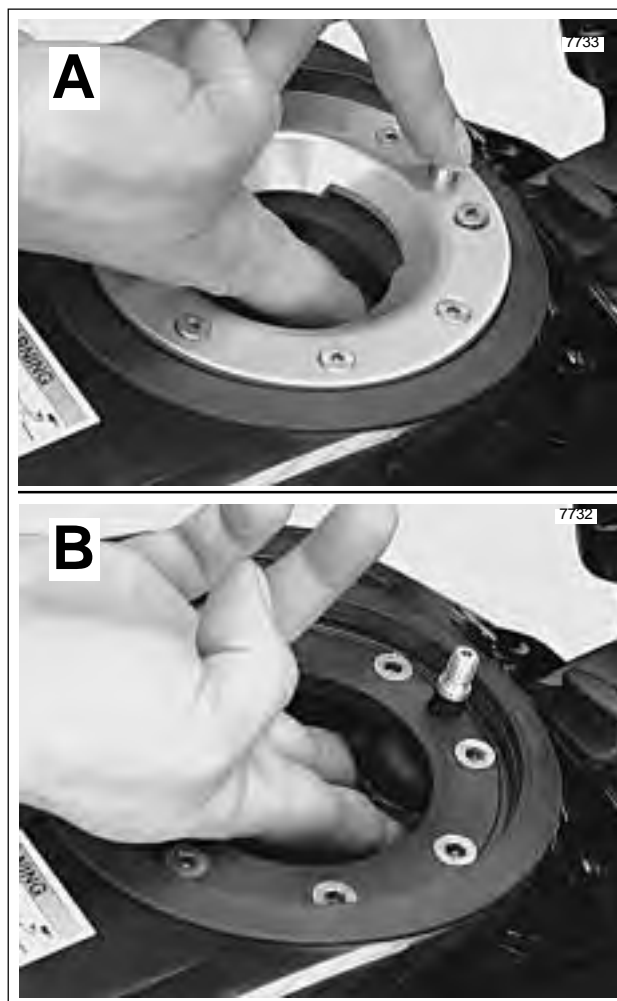


Figure 4-8. Remove Rollover Valve

8. See [Figure 4-8](#). Keeping fingers at bottom of rollover valve, push on threaded end to remove from holes in fuel cap flange and boot. Remove fuel cap flange and boot from fuel tank.
9. Maintaining hold of rollover valve, remove from hole in fuel tank. Exercise caution to avoid dropping valve into fuel tank.
10. See [Figure 4-7](#). Remove o-ring from groove in vent tube fitting. Discard o-ring.
11. Clean old HYLOMAR material from both sides of fuel cap boot, top of fuel tank, and bottom of fuel cap flange.

Installation

NOTE

The nozzle for the vent tube fitting should be at the 11 o'clock position when properly installed.

1. Install **new** o-ring into groove of vent tube fitting.
2. Spread HYLOMAR on both sides of fuel cap boot confining application to where boot makes contact with top of fuel tank and bottom of fuel cap flange.
3. Holding rollover valve in a vertical position with the threaded end at the top, insert into filler neck pushing threaded end up through hole in fuel tank. Exercise caution to avoid dropping valve into fuel tank.
4. With hole in boot aligned with hole in fuel cap flange, place over threaded end of rollover valve. Start vent tube fitting onto threads of rollover valve, but do not tighten.
7. Using a dial-type torque wrench on hex, final tighten vent tube fitting to 40-60 **in-lbs** (5-7 Nm). Verify that nozzle has not rotated out of 11 o'clock position.
8. Push hose onto outlet fitting at side of fuel supply valve. Turn slotted screw to tighten band clamp.
9. Push vent tube onto nozzle of vent tube fitting. Install small cable strap to fix location. Cut any excess cable strap material.
10. Insert bolt through battery negative cable (black) into threaded hole of battery negative (-) terminal. Tighten bolt to 72-96 in-lbs (8-11 Nm).

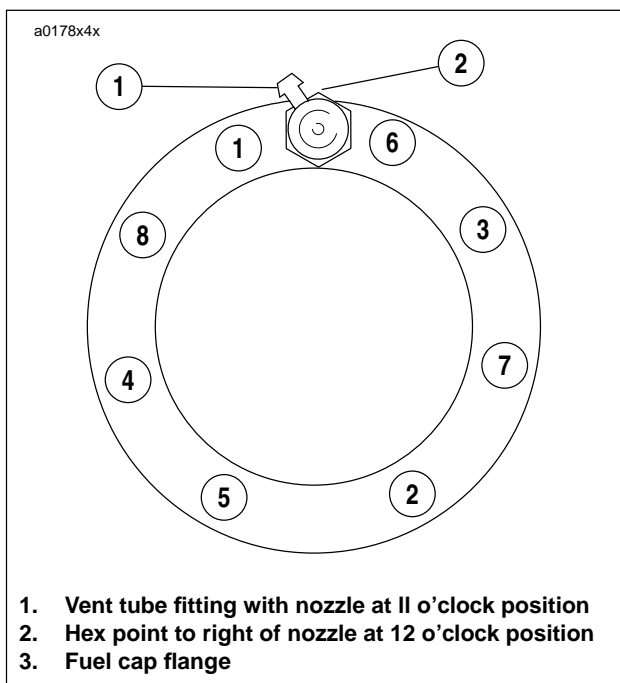


Figure 4-9. Filler Cap Flange Torque Sequence and Vent Tube Fitting Orientation

5. See [Figure 4-9](#). Using the proper torque sequence, alternately tighten eight fuel cap flange screws until snug. Following the same pattern, final tighten screws to 20-22 **in-lbs** (2-3 Nm).
6. Hand tighten vent tube fitting, so that nozzle is at the 11 o'clock position (with hex point to the right of the nozzle at 12 o'clock).

NOTE

If nozzle is not at the 11 o'clock position when hand tightened, loosen the fitting slightly, and reaching into filler neck with two fingers, slightly rotate body of rollover valve in a counter-clockwise direction. Hand tighten fitting again and observe orientation of nozzle. If nozzle is closer, repeat procedure. If further away, rotate body of valve in the opposite direction. A few attempts may be needed to achieve the desired result.

IMPORTANT NOTE

Do not overtighten vent tube fitting or attempt to tighten with standard "click-type" torque wrench. Overtightening fitting can snap off threaded end of rollover valve, possibly causing damaged parts to fall into fuel tank.

WARNING

After installing seat, pull upward on front of seat to be sure it is in locked position. While riding, a loose seat can shift causing loss of control, which could result in death or serious injury. (00070a)

11. Install seat.
12. Verify that handle of fuel supply valve is in the "OFF" position and fill the fuel tank.
13. Rotate handle of fuel supply valve to "ON" and carefully inspect for leaks. Return the valve to the "OFF" position when finished.

GENERAL

For removal, cleaning and inspection, and installation procedures, see 1.17 AIR CLEANER.

The air cleaner prevents foreign material from entering the carburetor and engine, trapping airborne dust and dirt in the filter element.

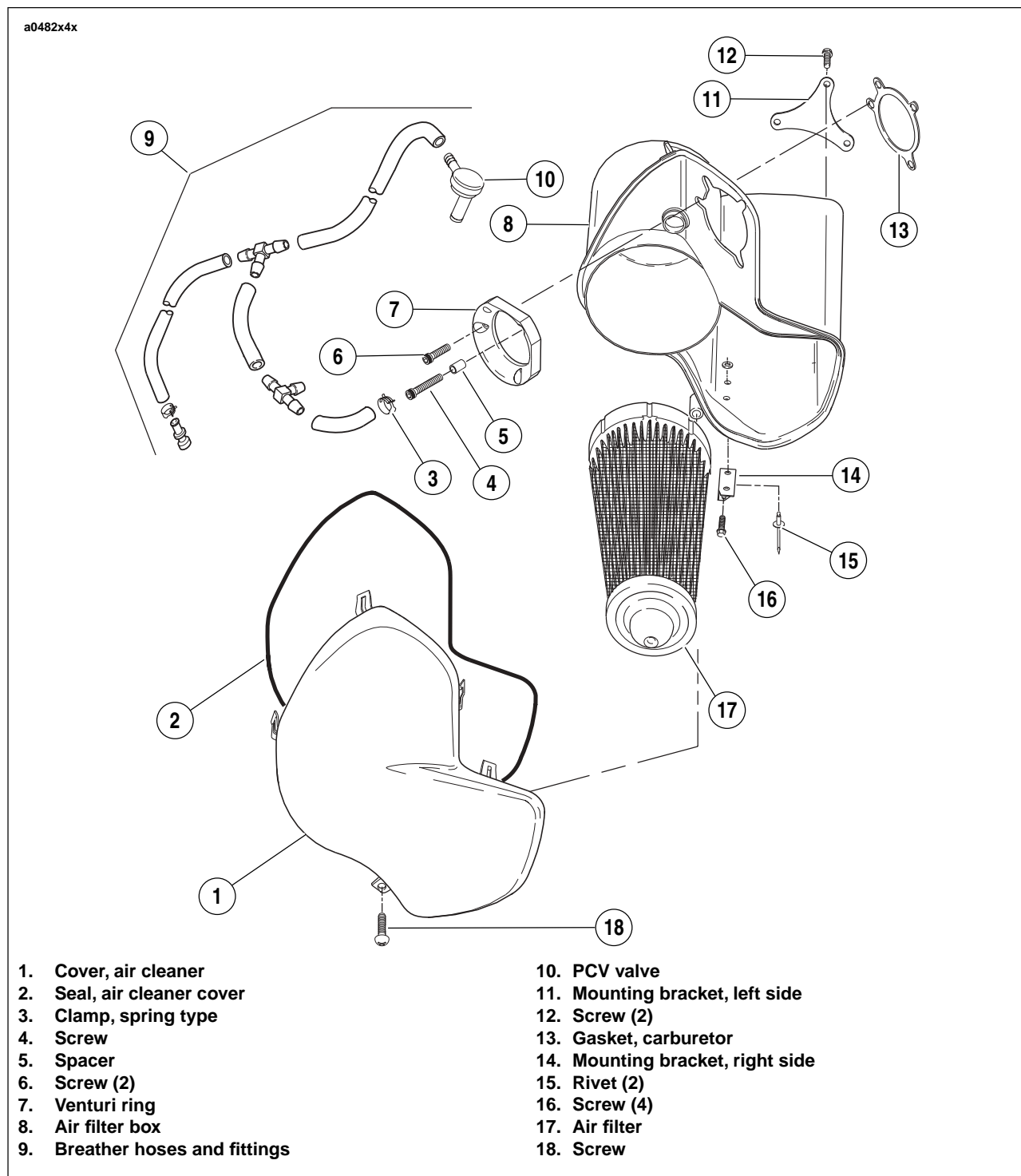


Figure 4-10. Air Cleaner Assembly

REMOVAL

1. Remove seat.

 **WARNING**

To prevent accidental vehicle start-up, which could cause death or serious injury, disconnect negative (-) battery cable before proceeding. (00048a)

2. Unthread bolt and remove battery negative cable (black) from battery negative (-) terminal.
3. Moving to left side of vehicle, rotate handle on fuel valve to the fully vertical position to shut the gasoline supply to the carburetor "OFF".
4. Remove air cleaner assembly. See 1.17 AIR CLEANER, steps 1-10.
5. Locate 6-place Deutsch connector in front of ignition coil and depress external latch to separate pin and socket halves.
6. Turn slotted screw to loosen band clamp on outboard side of manifold-carburetor coupler. Pull carburetor from coupler.

 **WARNING**

Gasoline can drain from the fuel line when disconnected from carburetor. Gasoline is extremely flammable and highly explosive, which could result in death or serious injury. Wipe up spilled fuel immediately and dispose of rags in a suitable manner. (00257a)

7. Using a side cutters, cut clamp and remove fuel inlet hose from fitting at side of carburetor.

NOTE

On California models, pull purge hose from fitting on same side of carburetor.

8. Rotate cable adjusters at handlebar to add slack to idle and throttle cables.

 **WARNING**

When removing the carburetor, keep assembly upright as the float bowl contains gasoline and will spill if tilted too far. Gasoline is extremely flammable and highly explosive, which could result in death or serious injury. Wipe up spilled fuel immediately and dispose of rags in a suitable manner. (00258a).

9. Loosen allen head screw to remove cable clamp at top of throttle cable bracket. Using a needle nose pliers, carefully pull idle cable barrel from hole in throttle wheel (farthest from cam stop). Pull throttle cable barrel from remaining hole in throttle wheel. Release idle and throttle cables from guides in throttle cable bracket and remove carburetor from vehicle.
10. Keeping carburetor upright, move to bench area. Without tilting carburetor or turning upside down, remove four Phillips screws at bottom to remove float bowl from carburetor body. Carefully pour gasoline in float bowl into a suitable container. Loosely install screws to fasten float bowl to carburetor body.
11. If carburetor cleaning is required, proceed as follows:
 - a. Using special TORX bit (Snap-on® TTXR20E), remove two tamper-resistant T20 TORX screws to release throttle position sensor from carburetor housing.
 - b. Remove Phillips screw (with lockwasher) to release stay plate on auto-enrichener from carburetor housing. Pull enrichener from carburetor bore.

INSTALLATION

1. If throttle position sensor and auto-enrichener were removed for carburetor cleaning, proceed as follows:
 - a. Align holes in throttle position sensor with those in carburetor housing. Using special TORX bit (Snap-on® TTXR20E), **loosely** install two tamper-resistant T20 TORX screws.
 - b. Carefully insert auto-enrichener into carburetor bore. Install Phillips screw (with lockwasher) to secure stay plate on enrichener to carburetor housing. Tighten screw to 13-23 **in-lbs** (2-3 Nm).
2. If loose, tighten four Phillips screws at bottom to secure float bowl to carburetor body.
3. Slide **new** clamp onto free end of fuel inlet hose. Install hose onto fitting at side of carburetor. Crimp clamp using HOSE CLAMP PLIERS (HD-97087-65B).

NOTE

On California models, push purge hose onto fitting on same side of carburetor.

4. Install sleeve on idle cable housing into longer cable guide on throttle cable bracket. Drawing idle cable downward, fit barrel end into hole in throttle wheel (farthest from cam stop). Install sleeve on throttle cable housing into shorter cable guide inserting barrel end into remaining hole in throttle wheel.
5. Verify that cables are seated in channel of throttle wheel, and using cable adjusters at handlebar, tighten cables as necessary to keep barrel ends from dislodging. Verify operation by turning throttle grip and observing cable action.

6. Position cable clamp at top of cable bracket, so that short end is above longer cable guide, long end above shorter cable guide. With clamp capturing sleeves on cable housings, tighten allen head screw to fix position.
7. Install carburetor onto manifold-carburetor coupler. Turn slotted screw to tighten band clamp on outboard side of coupler.
8. Mate pin and socket halves of 6-place Deutsch connector.
9. Adjust throttle cables. See [2.16 THROTTLE CONTROL](#).
10. Insert bolt through battery negative cable (black) into threaded hole of battery negative (-) terminal. Tighten bolt to 72-96 in-lbs (8-11 Nm).
11. Adjust throttle position sensor. For instructions, see [4.6 THROTTLE POSITION SENSOR](#), step 6.
12. Install air cleaner assembly. See [1.17 AIR CLEANER](#).

WARNING

After installing seat, pull upward on front of seat to be sure it is in locked position. While riding, a loose seat can shift causing loss of control, which could result in death or serious injury. (00070a)

13. Install seat.
14. Rotate handle of fuel valve to "ON" and carefully inspect for leaks. Return the valve to the "OFF" position when finished.
15. Adjust engine idle speed. See [1.19 IGNITION TIMING AND IDLE SPEED ADJUSTMENT](#).

DISASSEMBLY - TOP END

1. Remove gold Phillips screw (with top collar) to free throttle cable bracket from carburetor top. Remove gold Phillips screw (with lockwasher) at side of carburetor to release throttle cable bracket. Set bracket aside.
2. Remove three remaining top screws to release carburetor top from body.
3. Remove vacuum piston spring. Carefully raise diaphragm to remove vacuum piston assembly. Remove spring seat and jet needle from vacuum piston bore. See Figure 4-11.

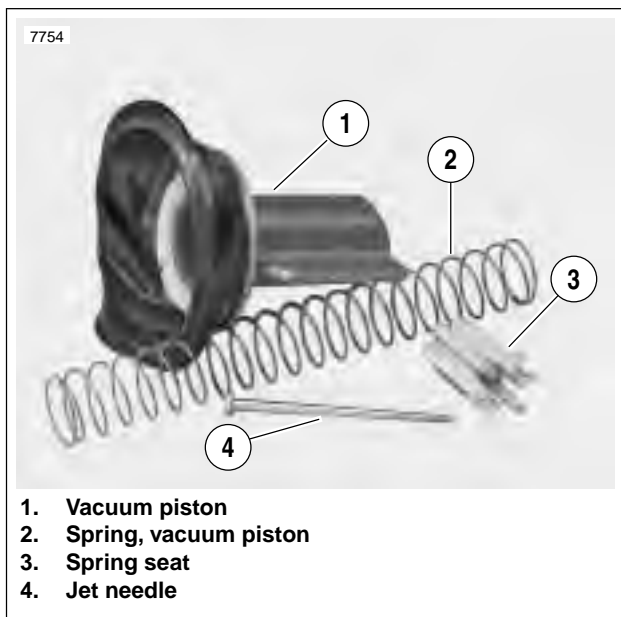


Figure 4-11. Carburetor-Top End Components

DISASSEMBLY - BOTTOM END

1. Turn carburetor upside down and remove four Phillips screws loosely installed at bottom. Remove float bowl from carburetor body.

IMPORTANT NOTE

Tapping the float pin out from the squared pedestal side will result in damage that requires carburetor replacement.

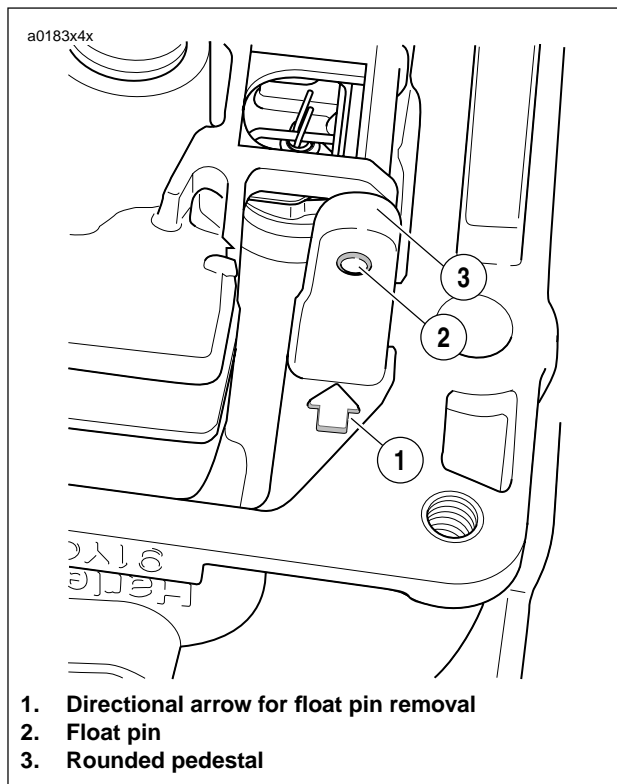


Figure 4-12. Remove Float Pin in Direction of Arrow

2. See Figure 4-12. Using a small center punch and hammer, carefully tap float pin from holes in pedestals. The rounded pedestal has an interference fit to ensure that the float pin is securely held, so always tap out the pin in the direction of the cast-in arrow (that is, from the interference side).

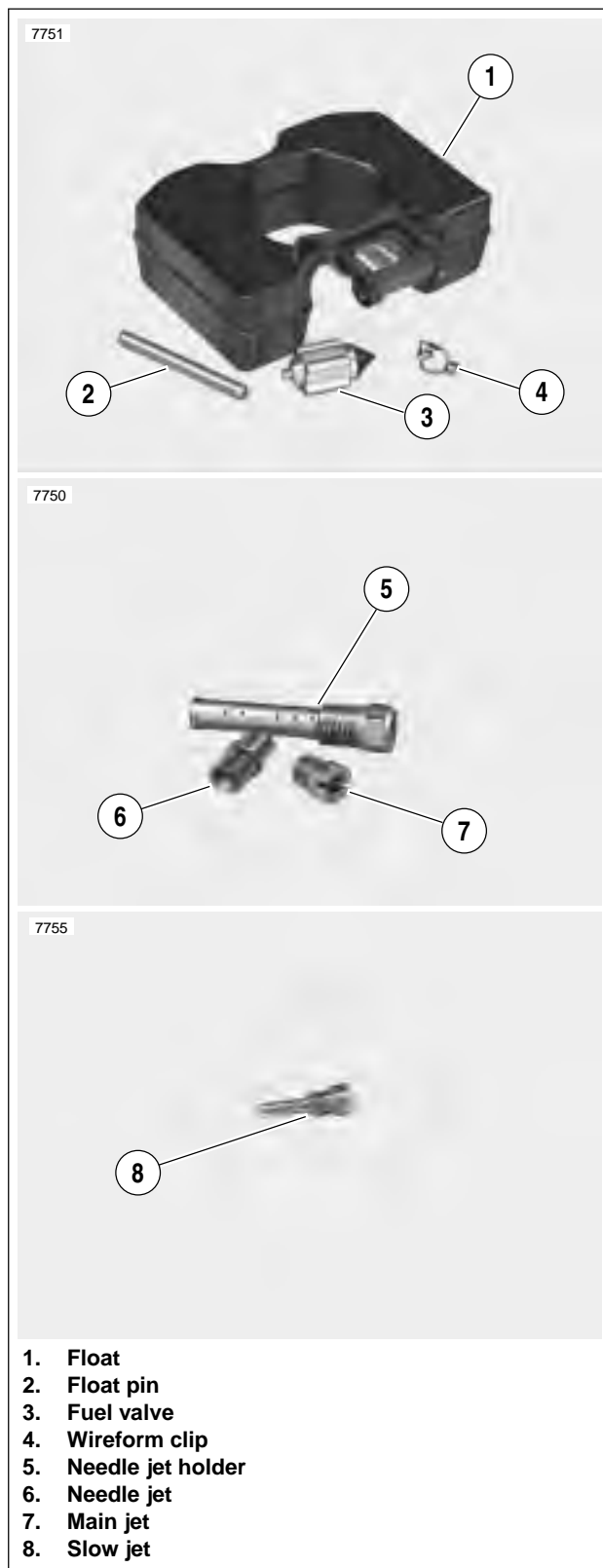


Figure 4-13. Carburetor- Bottom End

3. See [Figure 4-13](#). Remove float (1) and fuel valve (3). Carefully slide clip (4) and fuel valve (3) from tab on float (1). Remove wireform clip (4) from groove in fuel valve (3).

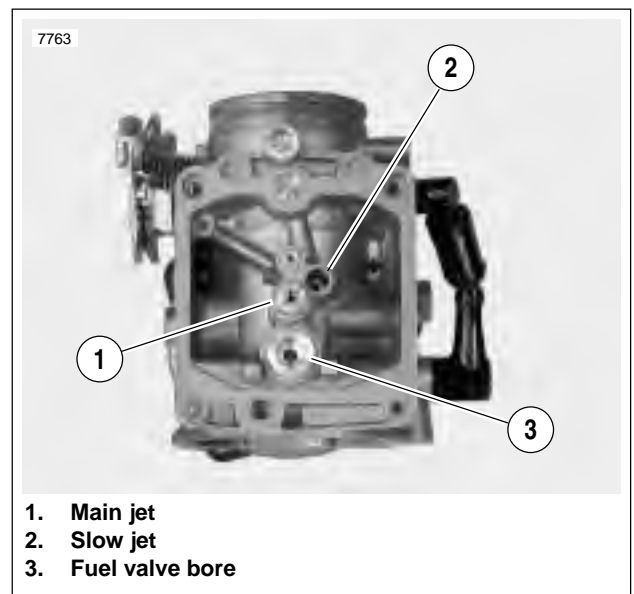


Figure 4-14. Carburetor Housing

4. See [Figure 4-14](#). Using slot at top, turn main jet (1) with flat tip screwdriver to unthread from needle jet holder. If necessary, hold hex on needle jet holder with a 5/16 inch wrench to prevent rotation.
5. Using a 5/16 inch wrench, turn hex on needle jet holder to unthread from main jet bore.
6. See [Figure 4-13](#). Turn carburetor right side up to drop out needle jet, which is loose in main jet bore.
7. See [Figure 4-14](#). Insert thin bladed flat tip screwdriver into slow jet bore, and using slot at top of slow jet (2), unthread to remove.

CLEANING AND INSPECTION

Carburetor Housing

⚠ WARNING

Compressed air can pierce the skin and flying debris from compressed air could cause serious eye injury. Wear safety glasses when working with compressed air. Never use your hand to check for air leaks or to determine air flow rates. (00061a)

Clean all internal air/fuel passages in carburetor housing with carburetor cleaner. Blow out passages using low pressure compressed air. Proceed as follows:

Slow Speed Circuit

1. See Figure 4-15. Spray carburetor cleaner into air inlet hole of slow speed circuit. While spraying, verify that solution exits slow jet bore at bottom of carburetor housing. Placing finger over slow jet bore, verify that solution exits four pin holes just inboard of the throttle plate, as well as the single pin hole outboard of the throttle plate.
2. Using a tapered, rubber-tipped nozzle on the air hose (to prevent both loss of air pressure and to avoid scratching or nicking the bore), apply low pressure compressed air into air inlet hole to blow carburetor cleaner out of slow jet bore. Placing gloved finger over slow jet bore, blow carburetor cleaner out of pin holes inboard and outboard of throttle plate.

Main Circuit

1. See Figure 4-15. Plugging main jet hole in carburetor throat, spray carburetor cleaner into air inlet hole of main circuit. While spraying, verify that solution exits main jet bore at bottom of carburetor housing.
2. Using a tapered, rubber-tipped nozzle on the air hose (to prevent both loss of air pressure and to avoid scratching or nicking the bore), apply low pressure compressed air into air inlet hole to blow carburetor cleaner out of hole in carburetor throat. Placing gloved finger over hole in carburetor throat, blow carburetor cleaner out of main jet bore at bottom of carburetor housing.

Float Bowl Vent

1. See Figure 4-15. Spray carburetor cleaner into air inlet hole of float bowl vent. While spraying, verify that solution exits two holes in float bowl chamber at bottom of carburetor housing.
2. Using a tapered, rubber-tipped nozzle on the air hose (to prevent both loss of air pressure and to avoid scratching or nicking the bore), apply low pressure compressed air into air inlet hole of float bowl vent to blow carburetor cleaner out of holes in float bowl chamber.

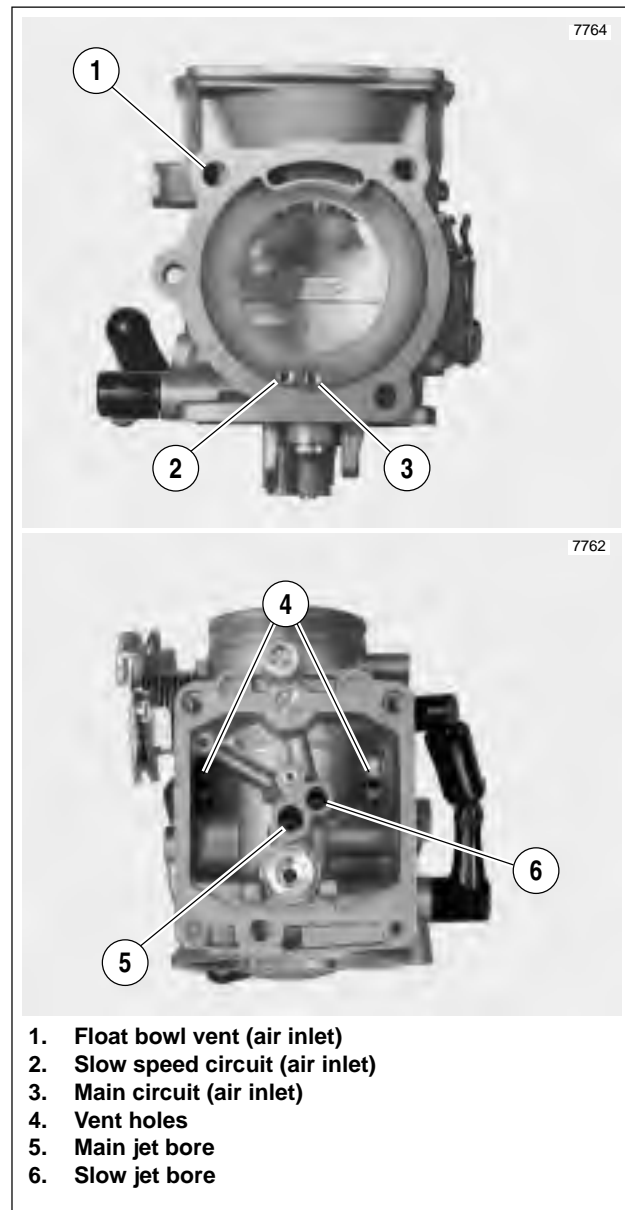


Figure 4-15. Air/Fuel Passages in Carburetor

Top End Components

WARNING

Compressed air can pierce the skin and flying debris from compressed air could cause serious eye injury. Wear safety glasses when working with compressed air. Never use your hand to check for air leaks or to determine air flow rates. (00061a)

1. See [Figure 4-11](#). Thoroughly clean all loose parts (except diaphragm) with carburetor cleaner. Blow dry using low pressure compressed air.
2. Inspect parts as follows:
 - a. Hold vacuum piston up to strong light source. Examine diaphragm for pin holes, cuts, tears or pinching. Replace if any damage is found.
 - b. Examine passage at bottom of vacuum piston bore. Verify that passage is clean and open.
 - c. Examine vacuum piston spring for stretching, crimping, distortion or other damage. Inspect spring seat for cracks. Replace parts if necessary.
 - d. Examine slides at sides of vacuum piston to verify that surfaces are clean and smooth. Clean or buff out any rough surfaces.
 - e. Examine tip of jet needle for grooves or scratches. Needle should be completely straight, while surface condition at taper should be smooth and even. Replace needle if necessary.

Bottom End Components

WARNING

Compressed air can pierce the skin and flying debris from compressed air could cause serious eye injury. Wear safety glasses when working with compressed air. Never use your hand to check for air leaks or to determine air flow rates. (00061a)

1. See [Figure 4-13](#). Thoroughly clean all loose parts with carburetor cleaner. Blow dry using low pressure compressed air.
2. Inspect parts as follows:
 - a. Inspect o-ring in groove of float bowl for cuts, tears or signs of deterioration. Replace o-ring if distorted or if sealing surface is damaged.
 - b. Inspect float pin for damage or distortion. Replace float pin if corroded, nicked or bent.
 - c. Clean float and inspect for cracks or other damage. Submerge float in a glass of water. Replace float if not water tight.
 - d. Depress pin on fuel valve to verify that it returns to the full-out position. Thoroughly clean valve with carburetor cleaner if pin is dirty or sticks. Inspect rubber cone on valve for dirt, cracks, hardening or wear. Inspect wireform clip for distortion. Replace fuel valve assembly if any of these conditions are found.
 - e. Inspect fuel valve seat in carburetor housing for dirt, damage or corrosion. Replace carburetor if seat damage or corrosion is present.
 - f. Verify cleanliness of slow jet. Be sure that all orifices are clean and open. Replace jet if damaged.

Verify cleanliness of main jet, needle jet holder and needle jet. Verify that orifices in needle jet holder are clean and open. Replace parts if damaged.

ASSEMBLY - TOP END

1. Install vacuum piston into carburetor body. Slides on piston are offset, so piston will fit into slide track groove only one way. If vacuum piston does not fit, rotate assembly 180°.
2. Insert jet needle into vacuum piston bore, so that it enters center hole at bottom. In the installed position, head of needle contacts boss at bottom of vacuum piston bore, while length of shaft resides in main jet bore.
3. With the legged side down, slide spring seat over top of needle in vacuum piston bore. Slide spring over spring seat.
4. Verify that lip on edge of diaphragm is seated in groove of carburetor flange.

NOTE

Diaphragm expands when in contact with fuel. If diaphragm is difficult to seat in groove because of this condition, allow diaphragm to dry before attempting to install.

5. Fit free end of spring over boss on inboard side of carburetor top, and keeping spring straight, align holes in top with those in flange.
6. Holding top to flange, check for proper diaphragm seal by pushing up on vacuum piston (from intake side) and releasing. If diaphragm is sealed correctly, very slight resistance should be felt when pushing up, and piston should be slow to extend. If piston movement is restricted, spring is cocked. Lift up on top and then lower carefully keeping spring coils straight.
7. Install three black top screws in holes furthest from throttle wheel. Alternately tighten screws until snug.
8. Slide gold top collar into remaining hole in carburetor top. With end of idle screw resting on top of throttle cam stop, align holes in throttle cable bracket with those in carburetor body and top cover. To prevent bending bracket or throttle cam, first install gold Phillips screw (with lock-washer) at side of carburetor. At carburetor top, install remaining Phillips screw.

ASSEMBLY - BOTTOM END

1. See [Figure 4-13](#). Insert slow jet into slow jet bore. Insert thin bladed flat tip screwdriver into bore, and using slot at top of slow jet, tighten until snug.
2. Place needle jet into main jet bore. Be sure end with chamfered edge and larger ID goes in first.
3. Insert needle jet holder into main jet bore, and using a 5/16 inch wrench, turn hex until snug.
4. Thread main jet into needle jet holder. Using slot at top of main jet, tighten with flat tip screwdriver until snug.
5. Install wireform clip into groove on pin side of fuel valve, if removed. Using wireform clip, carefully hang fuel valve onto tab of float, so that tip of rubber cone hangs flush with top of float (the top being the side opposite the pivot arm).
6. See [Figure 4-14](#). Place float into cavity of carburetor inserting fuel valve into bore between pedestals.

IMPORTANT NOTE

Tapping the float pin in from the rounded pedestal side will result in damage that requires carburetor replacement.

7. Insert float pin through squared pedestal and pivot arm of float into rounded pedestal. Since the rounded pedestal has an interference fit to ensure that the float pin is securely held, always install pin from the loose side (in the direction opposite the cast-in arrow). Using a small center punch and hammer, carefully tap float pin until ends are flush with outboard sides of pedestals.
8. Perform float level check as follows:
 - a. See [Figure 4-16](#). Place carburetor on a clean flat surface with the intake manifold side down.
 - b. Tilt the carburetor 15° to 20° in a counter clockwise direction until float comes to rest.

NOTE

The measurements will be incorrect if the carburetor is tilted less than 15° or more than 20°.

- c. Using a dial vernier caliper or dial caliper depth gauge, measure the distance from the face of the carburetor flange to the outboard edge of the float. Be careful not to push on float while measuring.
 - d. If the measurement is between 0.413 in. (mm) - 0.453 in. (10.49 -11.51 mm), then the float level is within specification. Proceed to step 9.
 - e. If the float level is not within specification, remove the float, and see [Table 4-6](#).
 - f. Install float and check float level again. Repeat procedure as necessary until float level is within specification.
9. Install **new** o-ring into groove of float bowl, if removed. Be sure to thoroughly clean groove before o-ring installation.
 10. Install four Phillips screws to secure float bowl at bottom of carburetor body. Tighten screws until snug.

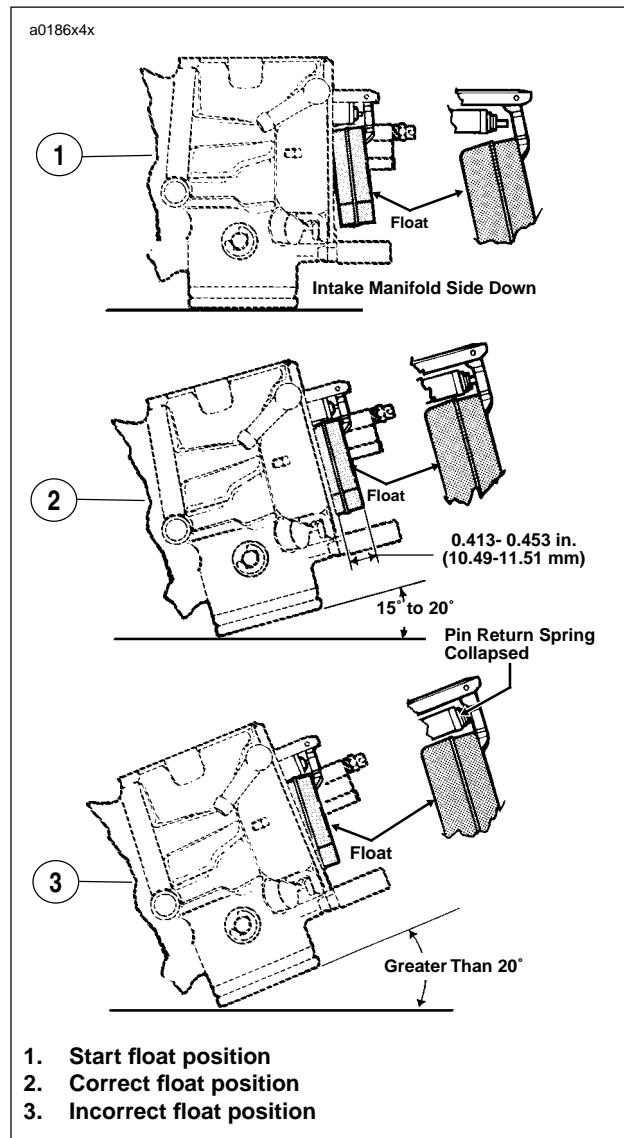


Figure 4-16. Float Check and Adjustment

Table 4-6. Float Level Adjustment

Float Measurement	Bend Float Level Tab	Amount of Gas in Float Bowl
To Increase	<u>Toward</u> Carburetor Body	Decreased
To Decrease	<u>Away from</u> Carburetor Body	Increased

GENERAL OPERATION

The auto-enrichener is one of the first idle devices to be operated by a wax element. A silicone liquid is enclosed in the wax and its volume increases or decreases with changes in temperature. Based upon whether the wax element is being cooled or heated, the enrichener valve automatically opens or closes.

See [Figure 4-17](#). During a cold start, the enrichener valve is open. Whether the valve is fully or partially open is dependent upon the ambient temperature. The extra fuel and air supplied to the engine causes it to idle fast.

See [Figure 4-18](#). Starting the vehicle also supplies 12 volts from the motorcycle power supply to the heater. As the heater warms the wax element, the silicone gradually expands to push the plunger out, eventually closing the enrichener valve at the end of its stroke. When the enrichener valve is closed

NOTE

About 2-5 minutes from the time the engine is first started cold, the passageway that supplies the extra fuel and air is blocked and the fast idle stops. (* May be as long as 10 minutes in very cold temperatures.)*

See [Figure 4-18](#). When the ignition is shut off, the power to the heater is cut. Deactivation of the heater causes the wax element to begin to cool. During some hot (warm) starts, the wax element may have cooled quicker than the engine, which can result in a fast idle period of short duration.

See [Figure 4-17](#). When the wax element has cooled sufficiently, the silicone gradually contracts to pull the plunger in. At the end of its return stroke, the enrichener valve is open and the vehicle is ready for the next cold start.

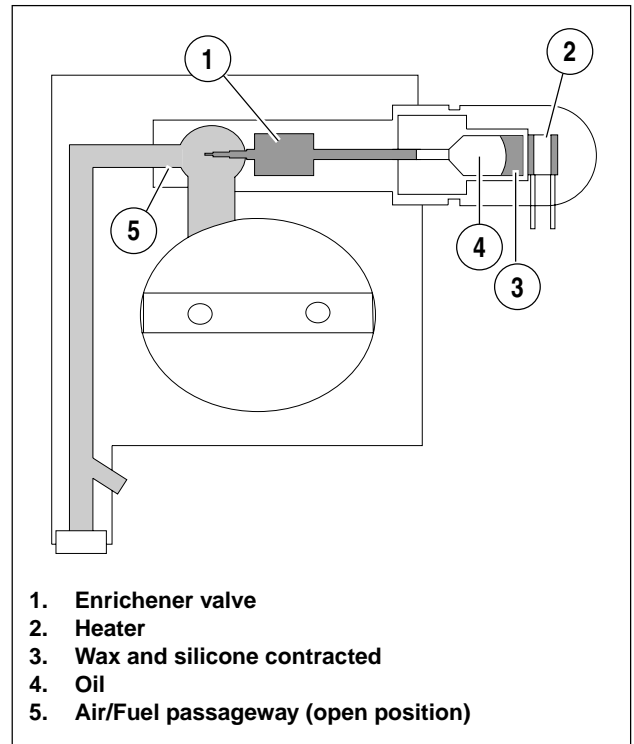


Figure 4-17. Cold Start/Plunger is Open

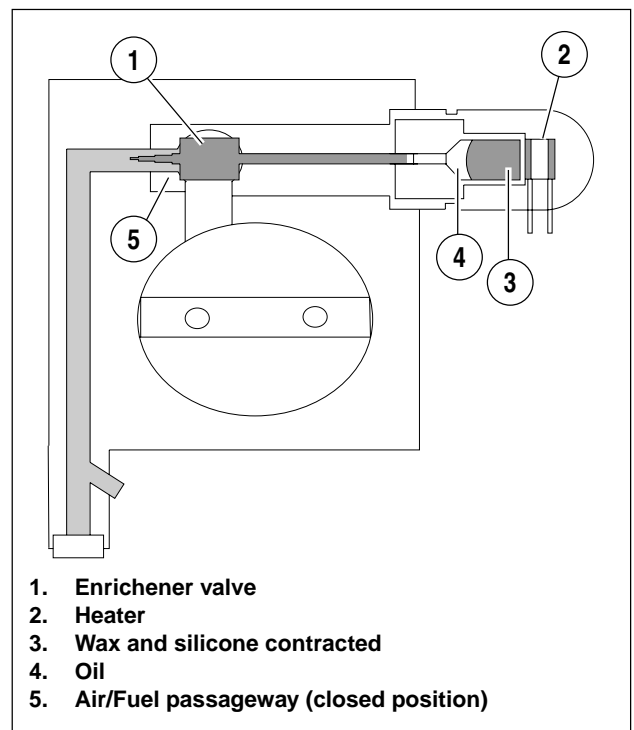


Figure 4-18. Hot Start/Plunger is Closed

REMOVAL

NOTE

For electrical diagnostics and troubleshooting, please refer to [7.7 AUTO-ENRICHENER](#).

1. Remove seat. Depress latch at bottom and pull seat up and back to remove.

WARNING

To prevent accidental vehicle start-up, which could cause death or serious injury, disconnect negative (-) battery cable before proceeding. (00048a)

2. Unthread bolt and remove battery negative cable (black) from battery negative (-) terminal.
3. Remove air cleaner assembly. See [1.17 AIR CLEANER](#).
4. Remove carburetor. See [4.4 CARBURETOR](#).
5. Locate 6-place Deutsch connector in front of ignition coil and depress external latch to separate pin and socket halves. Remove pin terminals from chambers 1 and 2.

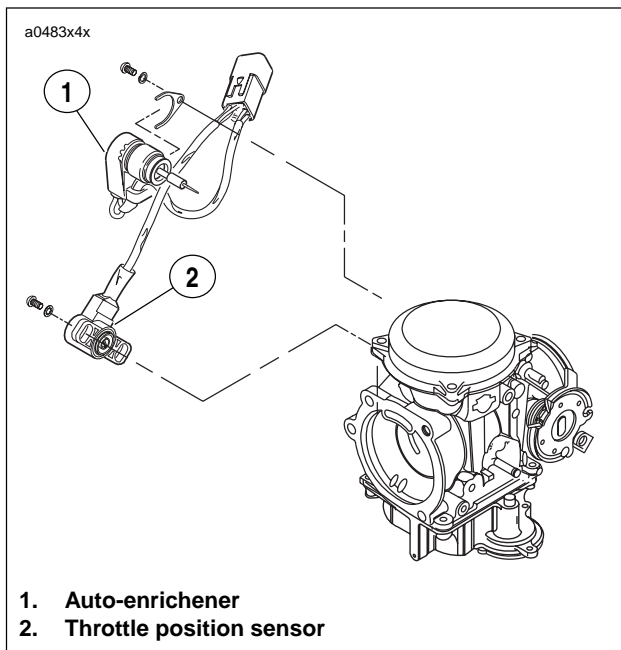


Figure 4-19. Location of Auto-Enrichener and Throttle Position Sensor

6. See [Figure 4-19](#). Remove Phillips screw (with lock washer) to release stay plate on auto-enrichener from carburetor housing. Pull enrichener from carburetor bore.

INSTALLATION

1. See [Figure 4-20](#). Obtain **new** auto-enrichener assembly. If old enrichener is used, inspect o-ring for cuts, tears or signs of deterioration. Replace o-ring if necessary.

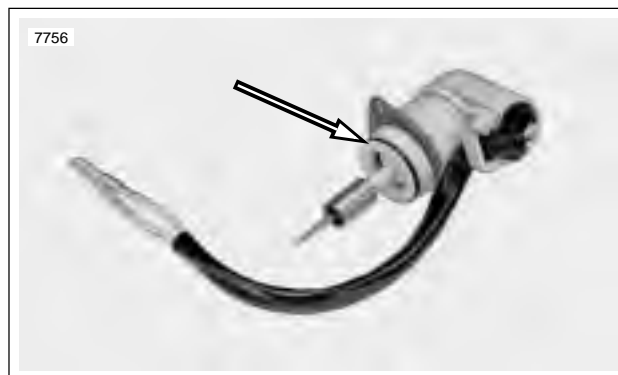


Figure 4-20. Auto-Enrichener with O-ring

2. Carefully insert auto-enrichener into carburetor bore. Install Phillips screw (with lock washer) to secure stay plate on enrichener to carburetor housing. Tighten screw to 13-23 **in-lbs** (2-3 Nm).
3. Locate 6-place Deutsch connector and install pin terminals in chambers 1 and 2. Mate pin and socket halves of connector.
4. Standing on the right side of the vehicle, start air box into opening. When partially installed, push PCV outlet hose onto middle fitting of 3-way connector, and loosely install carburetor onto manifold-carburetor coupler.
5. Moving to opposite side of vehicle, apply a small dab of Loctite 222 (Purple) to threads of two flange bolts. Slide bolts through top two holes of triangular bracket and install into left side of air box. Alternately tighten screws to 36-60 **in-lbs** (4-7 Nm).
6. Install carburetor. See [4.4 CARBURETOR](#).
7. Finish installing the air cleaner assembly. See [1.17 AIR CLEANER](#).
8. Insert bolt through battery negative cable (black) into threaded hole of battery negative (-) terminal. Tighten bolt to 72-96 **in-lbs** (8-11 Nm).

WARNING

After installing seat, pull upward on front of seat to be sure it is in locked position. While riding, a loose seat can shift causing loss of control, which could result in death or serious injury. (00070a)

9. Position seat on frame backbone, so that tongue at bottom engages slot in frame weldment. Push down on rear of seat until spring-loaded latch fully engages groove of seat pin.

REMOVAL

NOTE

For electrical diagnostics and troubleshooting, please refer to [7.4 THROTTLE POSITION SENSOR \(TP SENSOR\)](#).

1. Remove seat.

⚠ WARNING

To prevent accidental vehicle start-up, which could cause death or serious injury, disconnect negative (-) battery cable before proceeding. (00048a)

2. Unthread bolt and remove battery negative cable (black) from battery negative (-) terminal.
3. Remove air cleaner assembly. See [1.17 AIR CLEANER](#).
4. Remove carburetor assembly. See [4.4 CARBURETOR](#).
5. Locate 6-place Deutsch connector in front of ignition coil and depress external latch to separate pin and socket halves. Remove pin terminals from chambers 3 through 5.

NOTE

For instructions on properly removing wire terminals, see [SECTION 7, ELECTRICAL, DEUTSCH ELECTRICAL CONNECTORS](#).

6. Using special TORX bit (Snap-on® TTXR20E), remove two tamper-resistant T20 TORX screws to release throttle position sensor from carburetor. Pull sensor from carburetor bore.

INSTALLATION

1. See [Figure 4-21](#). Obtain **new** throttle position sensor. If old sensor is used, inspect o-ring for cuts, tears or signs of deterioration. Replace o-ring if necessary.

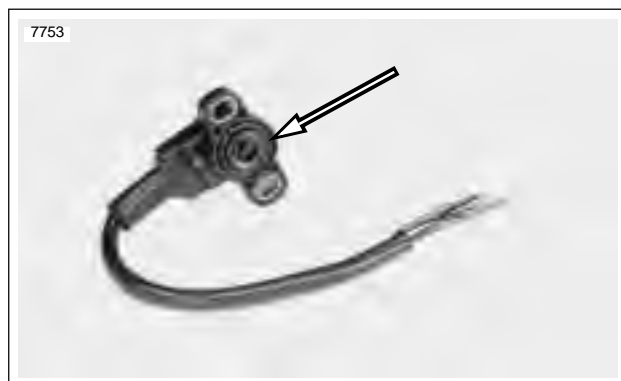


Figure 4-21. Throttle Position Sensor with O-ring

2. Align holes in throttle position sensor with those in carburetor housing. Using special TORX bit (Snap-on® TTXR20E), **loosely** install two tamper-resistant T20 TORX screws.

NOTE

The tamper-resistant screws are not to be tightened until the throttle position sensor has been properly adjusted. See the instructions under step 6 for details.

3. Locate 6-place Deutsch connector [88] and install pin terminals. Mate pin and socket halves of connector. Refer to [Table 4-7](#).

Table 4-7. Connector [88A]

CHAMBER NUMBER	WIRE COLOR	FUNCTION
3	Light blue	Output
4	Yellow	Input
5	Black	Ground

4. Insert bolt through battery negative cable (black) into threaded hole of battery negative (-) terminal. Tighten bolt to 72-96 **in-lbs** (8-11 Nm).
5. Install carburetor assembly. See [4.4 CARBURETOR](#).
6. Adjust throttle position sensor. See [7.4 THROTTLE POSITION SENSOR \(TP SENSOR\)](#).
7. Install air cleaner assembly. See [1.17 AIR CLEANER](#).

⚠ WARNING

After installing seat, pull upward on front of seat to be sure it is in locked position. While riding, a loose seat can shift causing loss of control, which could result in death or serious injury. (00070a)

8. Install seat.

NOTE

Be sure the engine is warmed up to normal operating temperature **BEFORE** adjusting engine idle speed.

9. Adjust engine idle speed, as follows: With the engine at normal operating temperature (auto-enrichener valve closed), adjust the throttle stop screw so the engine idles at 1200 RPM.

NOTE

To measure engine RPM, use a hand held inductive tachometer to pick up the signal off the spark plug cable.

GENERAL

See [Figure 4-22](#). Buell motorcycles sold in the state of California are equipped with an evaporative (EVAP) emissions control system. In conformance with California Air Resource Board (CARB) regulations, the EVAP system prevents both fuel and crankcase vapors from escaping into the atmosphere.

The EVAP system functions as follows:

- The fuel vapor **vent tube** connected to the fitting at the front of the fuel cap flange allows fuel vapors in the fuel tank to be vented through the rollover valve to the charcoal canister. If the vehicle is tipped, the rollover valve also prevents the loss of gasoline through the vent tube.
- When the engine is running, negative pressure (vacuum) created at the carburetor venturi draws the fuel vapors stored in the charcoal canister through the **purge hose** to the carburetor where they are burned as part of the normal combustion process.
- Fuel vapors emanating from the carburetor throat are drawn to the charcoal canister through a fitting on the **PCV outlet hose**. A preformed hose on one end of the

fitting is fixed to an allen head screw on the venturi ring for positive location.

- Crankcase vapors passing through the PCV valve follow the fuel vapors to the charcoal canister via a 3-way fitting plumbed into the PCV outlet hose. The fuel and crankcase vapors, after passing through the charcoal canister, travel through the purge hose to the carburetor, and like the vapors from the fuel tank, are burned during combustion.

⚠ WARNING

Keep evaporative emissions vent lines away from exhaust and engine. Gasoline is extremely flammable and highly explosive, which could result in death or serious injury. (00266a)

NOTE

The EVAP system has been designed to operate with a minimum of maintenance. Check that all hoses are correctly routed and properly connected. Also, verify that the hoses are not pinched or kinked.

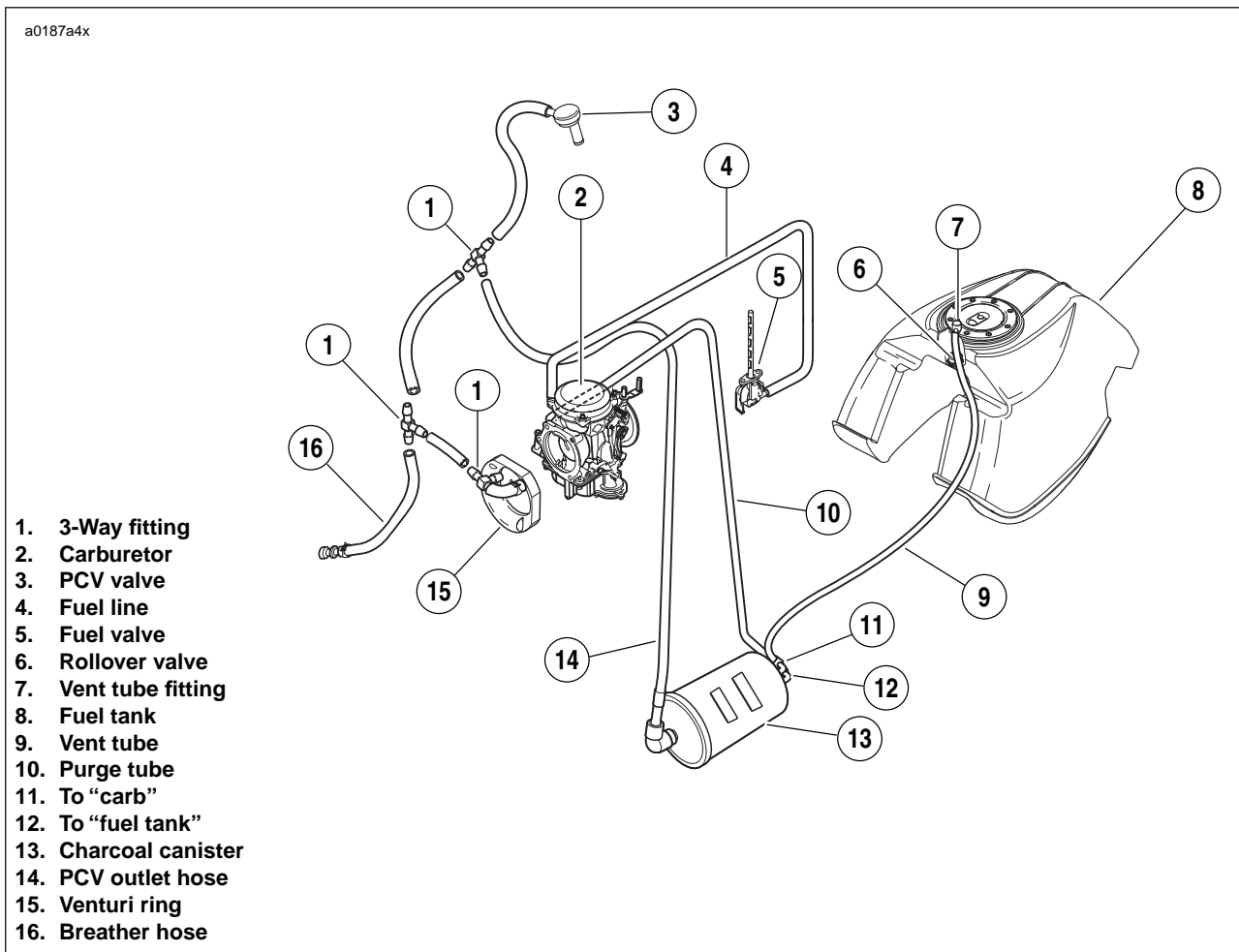


Figure 4-22. California Evaporative Emissions Control System Schematic

CHARCOAL CANISTER

NOTE

On 49 State models, the charcoal canister is absent and the fuel vapor vent tube is vented to the atmosphere.

Removal

1. Remove seat.

⚠ WARNING

Disconnect negative (-) battery cable first. If positive (+) cable should contact ground with negative (-) cable connected, the resulting sparks can cause a battery explosion, which could result in death or serious injury. (00049a)

2. Unthread bolt and remove battery negative cable (black) from battery negative (-) terminal.

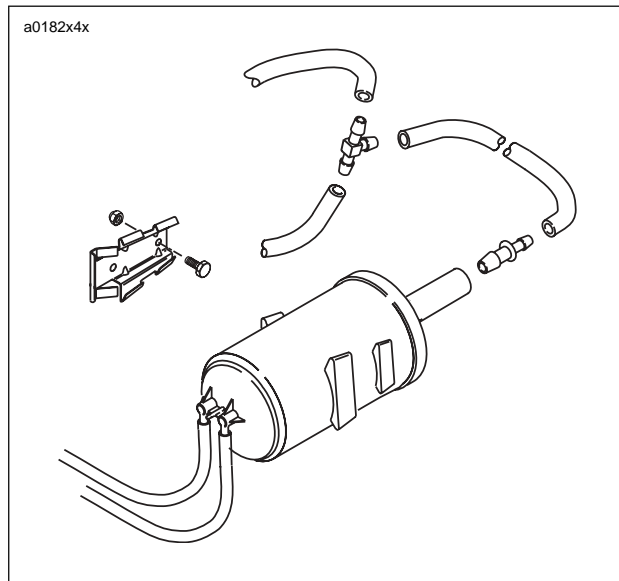
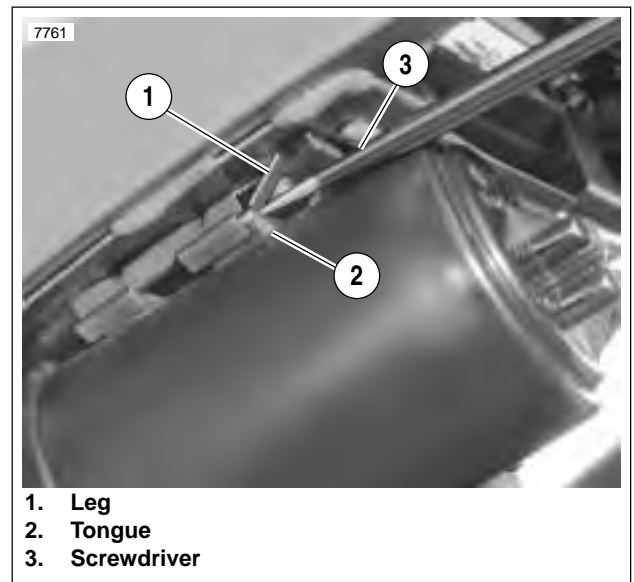


Figure 4-23. Charcoal Canister Assembly

3. See Figure 4-23. Standing on left side of vehicle, pull two vent tubes from fittings at the back of the charcoal canister. For correct assembly, mark tubes to correlate with stamps on canister. Mark one tube "CARB" and the other "TANK."
4. Pull PCV outlet hose (connection from carburetor throat and PCV valve) from fitting at front of charcoal canister.



1. Leg
2. Tongue
3. Screwdriver

Figure 4-24. Push Up On Legs Of Bracket To Release Charcoal Canister

5. See Figure 4-24. Slide charcoal canister rearward until backside of tongue at top of canister just contacts two legs on bracket. Holding canister in position, use the tip of a large screwdriver to push up on outboard leg until it comes down to rest on top of tongue. Repeat procedure to release leg on inboard side of bracket.
6. Slide charcoal canister toward rear of vehicle until tongue at top of canister is completely free of grooves in bracket.

Installation

1. With the vent tube fittings at the rear and pointing inboard, start tongue at top charcoal canister into grooves of bracket.
2. Push charcoal canister toward front of vehicle until legs on bracket snap down to engage back of tongue.
3. Attach vent tubes to fittings at back of charcoal canister. For correct assembly, tubes should have been marked to correlate with stamps on canister, that is, either "CARB" or "TANK."
4. Attach PCV outlet hose (connection from carburetor throat and PCV valve) to fitting at front of charcoal canister.

WARNING

Keep evaporative emissions vent lines away from exhaust and engine. Gasoline is extremely flammable and highly explosive, which could result in death or serious injury. (00266a)

5. Recheck vent tube routing to be sure that hoses are not pinched or kinked.
6. Insert bolt through battery negative cable (black) into threaded hole of battery negative (-) terminal. Tighten bolt to 72-96 in-lbs (8-11 Nm).

WARNING

After installing seat, pull upward on front of seat to be sure it is in locked position. While riding, a loose seat can shift causing loss of control, which could result in death or serious injury. (00070a)

7. Install seat.

HOSE ROUTING

Crankcase Breather/Drain/PCV Outlet Hose

Crankcase Breather Hose: See Figure 4-26. The crankcase breather hose runs forward from the PCV valve at the top of the rocker cover through a cable strap loosely installed in two lateral holes in the front engine mounting bracket (just rear of the steering head). After passing through the cable strap, the hose loops rearward following the bottom left side of the frame backbone, where it is captured in yet another cable strap loosely installed around the middle of the backbone (the second of three equally spaced cable straps moving front to rear). Continuing rearward, the hose passes toward the right side of the vehicle just in front of the ignition coil where it mates with a 3-way connector positioned inboard of the carburetor.

First 3-Way Connector: The 3-way connector inboard of the carburetor splits the path of the hose into two directions. The center barb, pointed at the left side of the vehicle, is attached to the hose routed to the charcoal canister, while the end barb is connected to a short hose that jumps to a second 3-way connector located inboard of the air box.

Charcoal Canister Hose: The hose to the charcoal canister is routed from the center barb on the first 3-way connector back to the left side of the vehicle just behind the ignition coil, and then downward following the rearward arc created by the rounded top of the air box. The hose then runs over the top rear corner of the inner primary housing and enters the loop formed by the hose connected to the oil drain/return fitting at the left side of the frame backbone. Passing through this loop, the hose enters an opening at the front of the passenger foot peg support where it is then connected to the fitting at the front of the charcoal canister.

Second Three-Way Connector: The second 3-way connector inboard of the air box splits the path of the hose once again. The center barb, pointed at the right side of the vehicle, is connected to a hose that runs through a hole in the air box, where it mates with a third and final 3-way connector. The hose on the end barb of the third 3-way connector is clamped to the gold allen head screw on the venturi ring (so that the center barb is positioned at the carburetor throat).

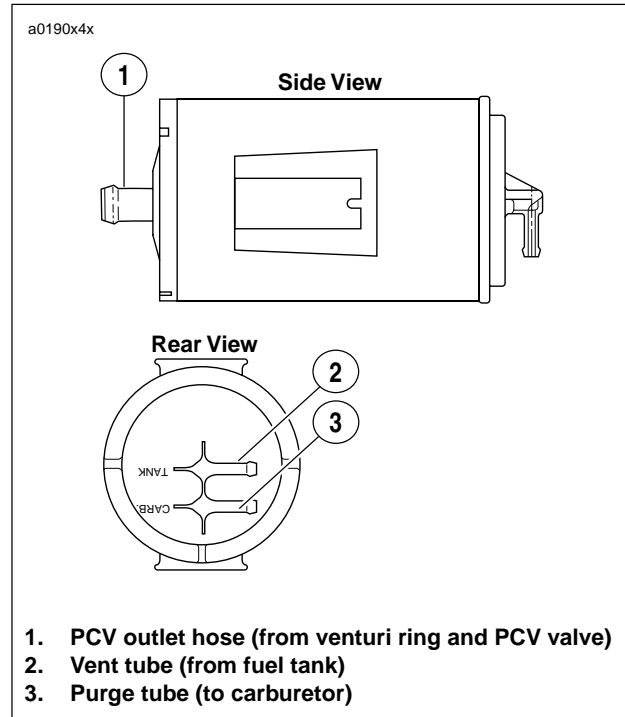


Figure 4-25. Charcoal Canister

Crankcase Breather Drain Hose: The end barb of the second 3-way connector routes the hose to the right side of the vehicle between the top of the air box and the bottom of the frame backbone, where it runs rearward following the bottom right side of the frame backbone. The hose then cuts back to the left side of the vehicle through the opening formed by the frame and the rear of the air box (just above the electric starter). After returning to the left side, the hose passes through the loop formed by the hose connected to the oil drain/return fitting. The hose enters an opening at the front of the passenger foot peg support where it is then clamped along the inboard side above the oil drain hose.

Vent Tube

See [Figure 4-26](#). The vent tube, which is cable strapped to the nozzle of the vent tube fitting at the front of the fuel cap flange, runs downward on the left side of the fuel tank and turns rearward passing through a cable strap loosely installed around the front of the frame backbone (the first of three equally spaced cable straps moving front to rear). From this point, the vent tube follows the main harness through a large hole in the front engine mounting bracket (just rear of the two lateral holes described earlier). Continuing rearward, the tube follows the bottom left side of the frame backbone running inboard of the crankcase breather hose. Moving outboard of the breather hose just in front of the ignition coil, the tube follows the ignition module conduit down the left side of the frame backbone and passes through the loop formed by the hose connected to the oil drain/return fitting. The tube enters an opening at the front of the passenger foot peg support where it runs rearward to connect to the upper fitting at the back of the charcoal canister. One cable strap is used to con-

nect the “carb” and “tank” vent tubes together at the back of the canister, while another secures both tubes to the PCV outlet hose at the front of the canister.

NOTE

On non-California models, the end of the “tank” vent tube gets routed through the slot at the front of the tail section and then into the cavity on the inboard side of the battery box (alongside the transmission vent hose), while the “carb” vent tube (purge tube) is absent.

Purge Tube

The purge tube is connected to a fitting on the inboard side of the carburetor, where it passes to the right side of the vehicle just behind the ignition coil. From this point, the tube runs rearward following the same path as the hose to charcoal canister (front fitting), except that it is connected to the lower fitting at the back of the canister.

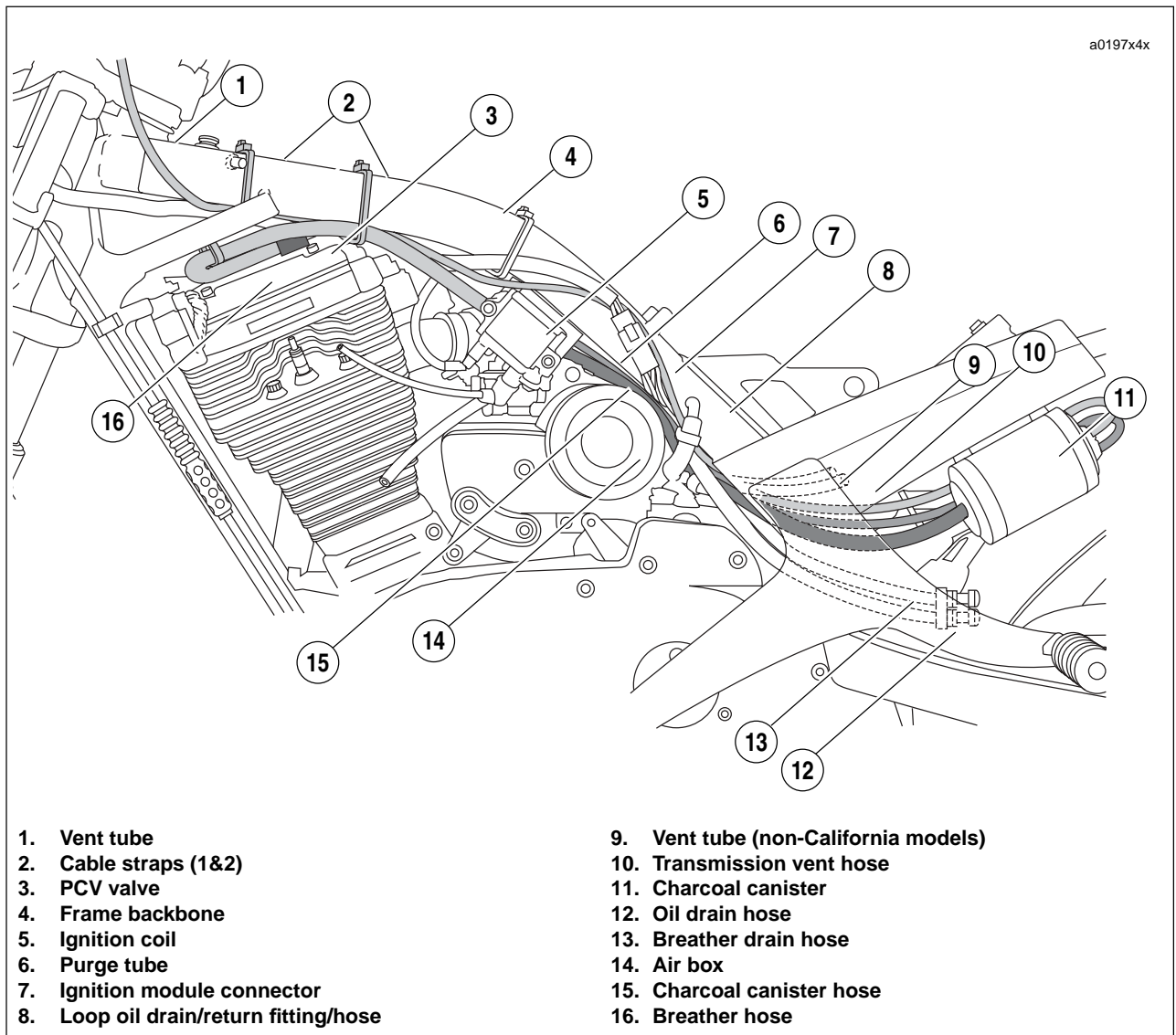


Figure 4-26. Hose Routing (Left Side View)

NOTES

[Table Of Contents](#)

ELECTRIC STARTER 5

SUBJECT	PAGE NO.
5.1 Specifications	5-1
5.2 Electric Starter System	5-2
5.3 Starter Diagnostics	5-5
5.4 Starter Activation Circuits	5-7
5.5 Diagnostics/Troubleshooting	5-8
5.6 Starter System Testing	5-10
5.7 Starter	5-11
5.8 Starter Solenoid	5-20

Table 5-1. Starter Specifications

ELECTRICAL INFORMATION	
Free Speed	3000 RPM (min.) @ 11.5 V
Free Current	90 Amp (max.) @ 11.5 V
Stall Current	400 Amp (max.) @ 2.4 V
Stall Torque	8.1 ft-lbs (11.0 Nm) (min.) @ 2.4 V

Table 5-2. Service Wear Limits

STARTER COMPONENTS	IN.	MM
Brush Length minimum	0.433	11.0
Commutator Diameter minimum	1.141	28.981

TORQUE VALUES

ITEM	TORQUE		NOTES
Battery terminal bolts	72-96 in-lbs	8-11 Nm	Page 5-19
Starter battery positive cable nut	80-100 in-lbs	9-11 Nm	Metric, Page 5-19
Starter mounting bolts	13-20 ft-lbs	18-27 Nm	Page 5-19

GENERAL

The starter is made up of an armature, field winding assembly, solenoid, drive assembly, idler gear and drive housing.

The starter motor torque is increased through gear reduction. The gear reduction consists of the drive pinion on the armature, an idler gear and a clutch gear in the drive housing. The idler gear is supported by rollers. The clutch gear is part of the overrunning clutch/drive assembly.

The overrunning clutch is the part which engages and drives the clutch ring gear. It also prevents the starter from overrunning. The field windings are connected in series with the armature through brushes and commutator segments.

Wiring Diagrams

For additional information concerning the starting system circuit, see the wiring diagram at the end of Section 7, ELECTRICAL.

Starter Relay

The starter relay is not repairable. Replace the unit if it fails.

Starter Interlock

See [7.11 STARTER/IGNITION INTERLOCK](#) for operation and troubleshooting information.

OPERATION

NOTE

The clutch lever must be pulled in for the starting system to function.

See [Figure 5-1](#). When the starter switch is pushed, the starter relay is activated and battery current flows into the pull-in winding (10) and the hold-in winding (11), to ground.

The magnetic forces of the pull-in and hold-in windings in the solenoid push the plunger (7) causing it to shift to the left. This action engages the pinion gear (1) with the clutch ring gear (13). At the same time, the main solenoid contacts (8) are closed, so battery current flows directly through the field windings (3) to the armature (4) and to ground. Simultaneously, the pull-in winding (10) is shorted.

The current continues flowing through the hold-in winding (11) keeping the main solenoid contacts (8) closed. At this point, the starter begins to crank the engine.

After the engine has started, the pinion gear (1) turns freely on the pinion shaft through the action of the overrunning clutch (12). The overrunning clutch prevents the clutch ring gear (13) (which is now rotating under power from the engine) from turning the armature (4) too fast.

When the starter switch is released, the current of the hold-in winding (11) is fed through the main solenoid contacts (8) and the direction of the current in the pull-in winding (10) is reversed. The solenoid plunger (7) is returned to its original position by the return spring, which causes the pinion gear (1) to disengage from the clutch ring gear (13).

a0191x5x

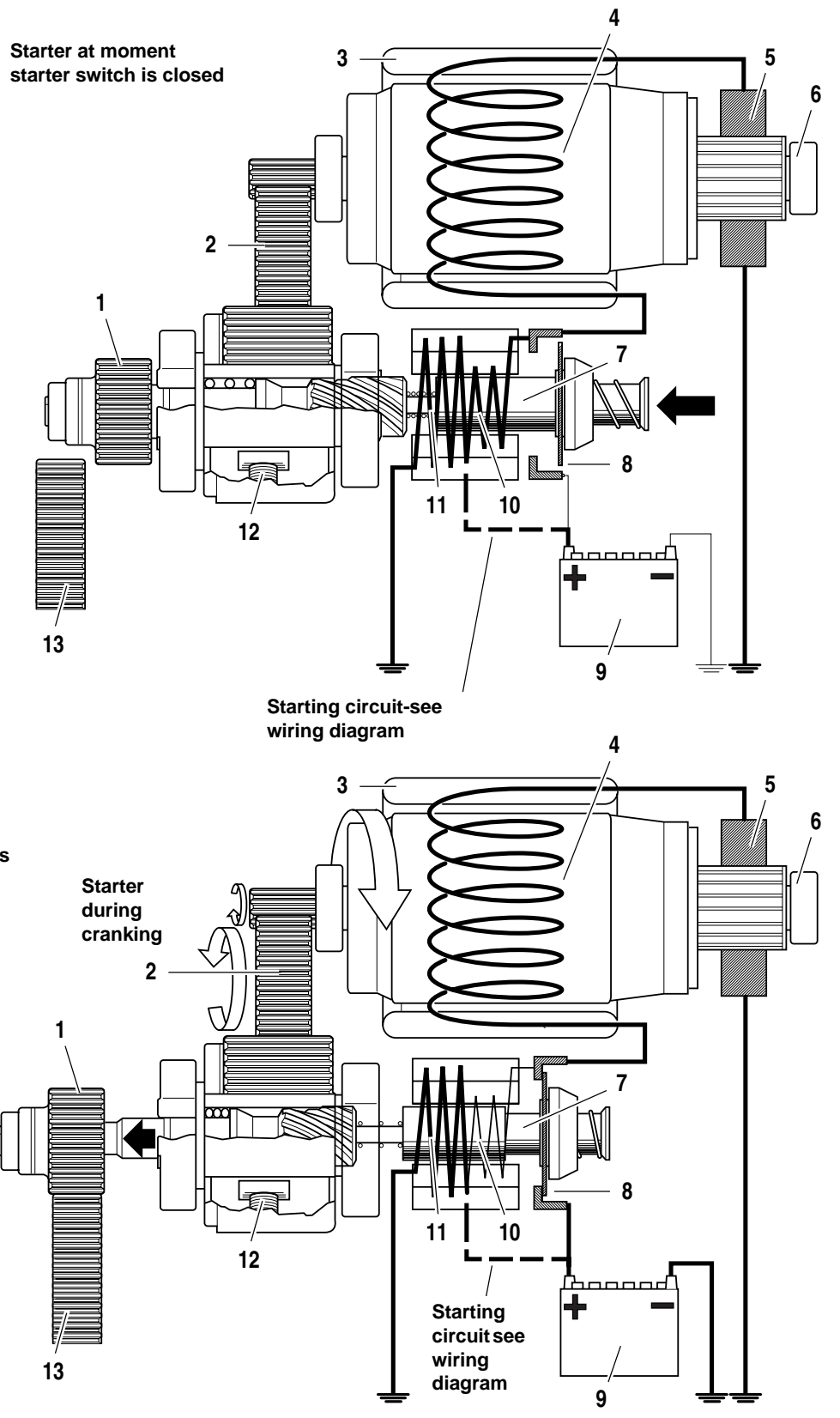


Figure 5-1. Starter Operation

STARTER TROUBLESHOOTING

Table 5-3. Starter Troubleshooting

SOURCE OF PROBLEM	PROBABLE CAUSE	SOLUTION
Battery	Voltage drop due to discharged battery.	Charge battery.
	Short-circuit or open between electrodes.	Replace battery.
	Poor contact condition of battery terminal(s).	Clean and retighten.
Wiring	Disconnection between starter switch and solenoid terminal.	Repair or replace wire.
	Malfunction in starter interlock system.	See 7.11 STARTER/IGNITION INTERLOCK .
Starting Switch or Starter Relay	Poor contact condition or poor connection.	Replace.
Solenoid	Poor contact condition caused by burnt contact.	Polish contact surface or replace solenoid assembly. Repair.
	Contact plate removed.	Replace solenoid assembly.
	Pull-in winding open or short-circuit.	
	Hold-in winding open.	Check brush spring tension.
Starting Motor	Poor contact condition of brushes. Commutator burnt.	Correct on lathe or replace.
	Commutator high mica.	Correct by undercutting.
	Field winding grounded.	Replace.
	Armature winding grounded or short-circuited.	
	Reduction gears damaged.	
	Insufficient brush spring tension.	
	Disconnected lead wire between solenoid and field windings.	Repair or replace lead wire.
	Ball bearing sticks.	Replace bearing.
Battery	Voltage drop due to discharged battery.	Charge battery.
	Short-circuit or open between electrodes.	Replace battery.
	Poor contact condition of battery terminal(s).	Clean and retighten.
Wiring	Disconnection between starter switch and solenoid terminal.	Repair or replace wire.
Overrunning Clutch	Overrunning clutch malfunction (rollers or compression spring).	Replace overrunning clutch.
	Pinion teeth worn out.	
	Pinion does not run in overrunning direction.	
	Poor sliding condition of spline teeth.	Remove foreign materials, dirt, or replace overrunning clutch.
	Reduction gears damaged.	Replace overrunning clutch and idler gear.
Ring Gear	Excessively worn teeth.	Replace ring gear.
Solenoid	Return spring worn.	Replace solenoid.
	Coil layer shorted.	
	Contact plate melted and stuck.	
Starting Switch or Starter Relay	Unopened contacts.	Replace starting switch or starter relay.
	Poor returning.	

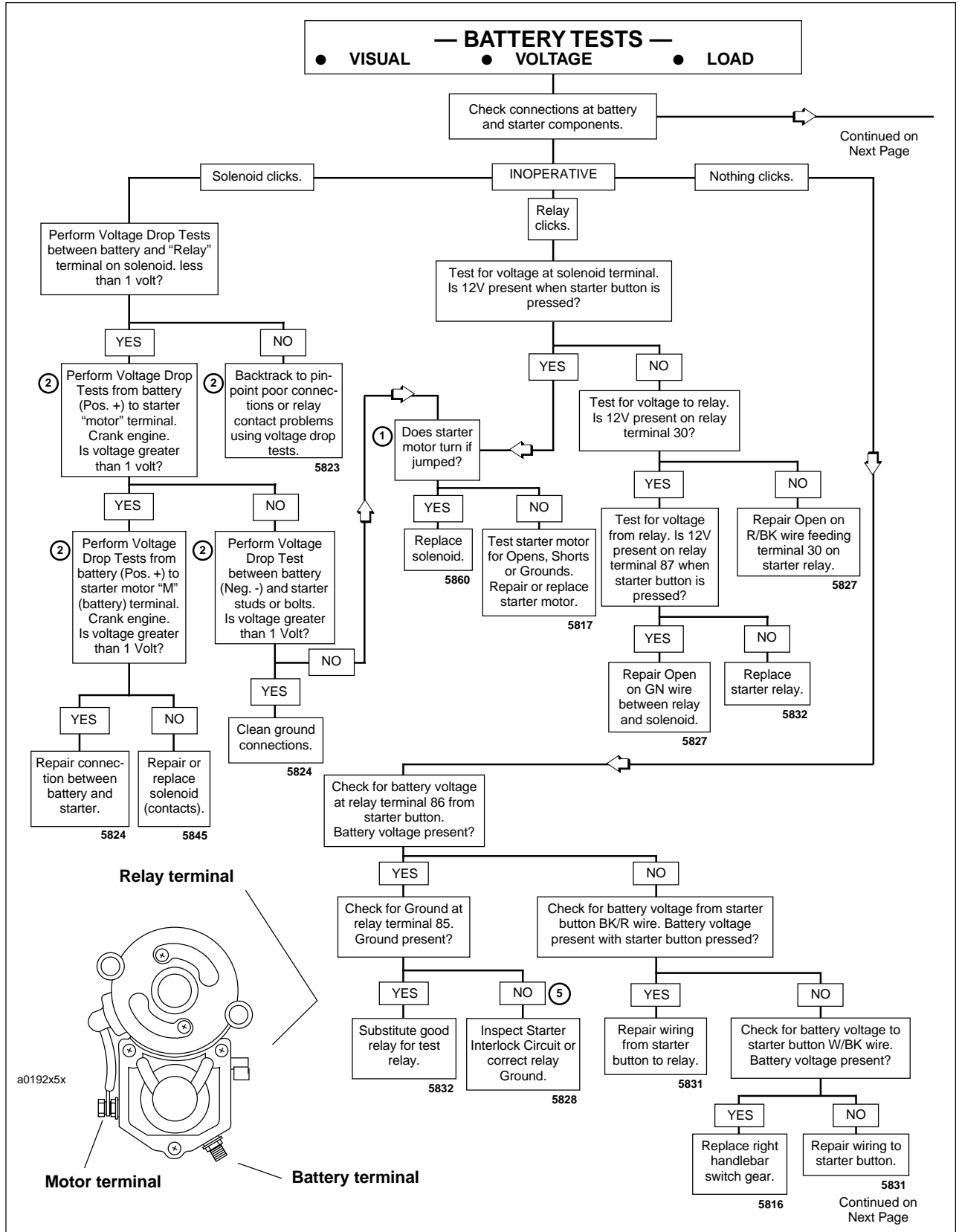


Figure 5-2. Starting System Diagnosis, Part 1

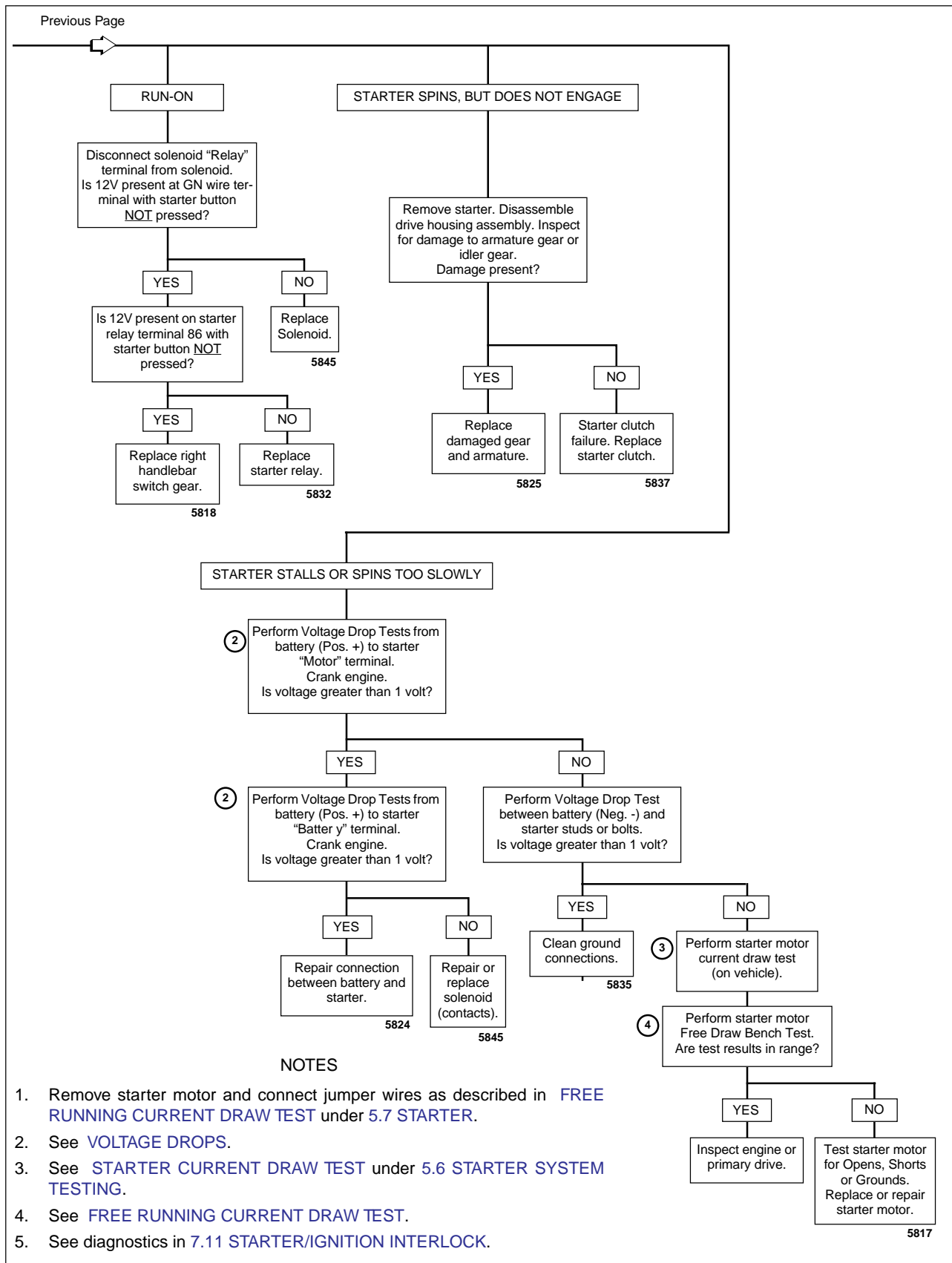


Figure 5-3. Starting System Diagnosis, Part 2

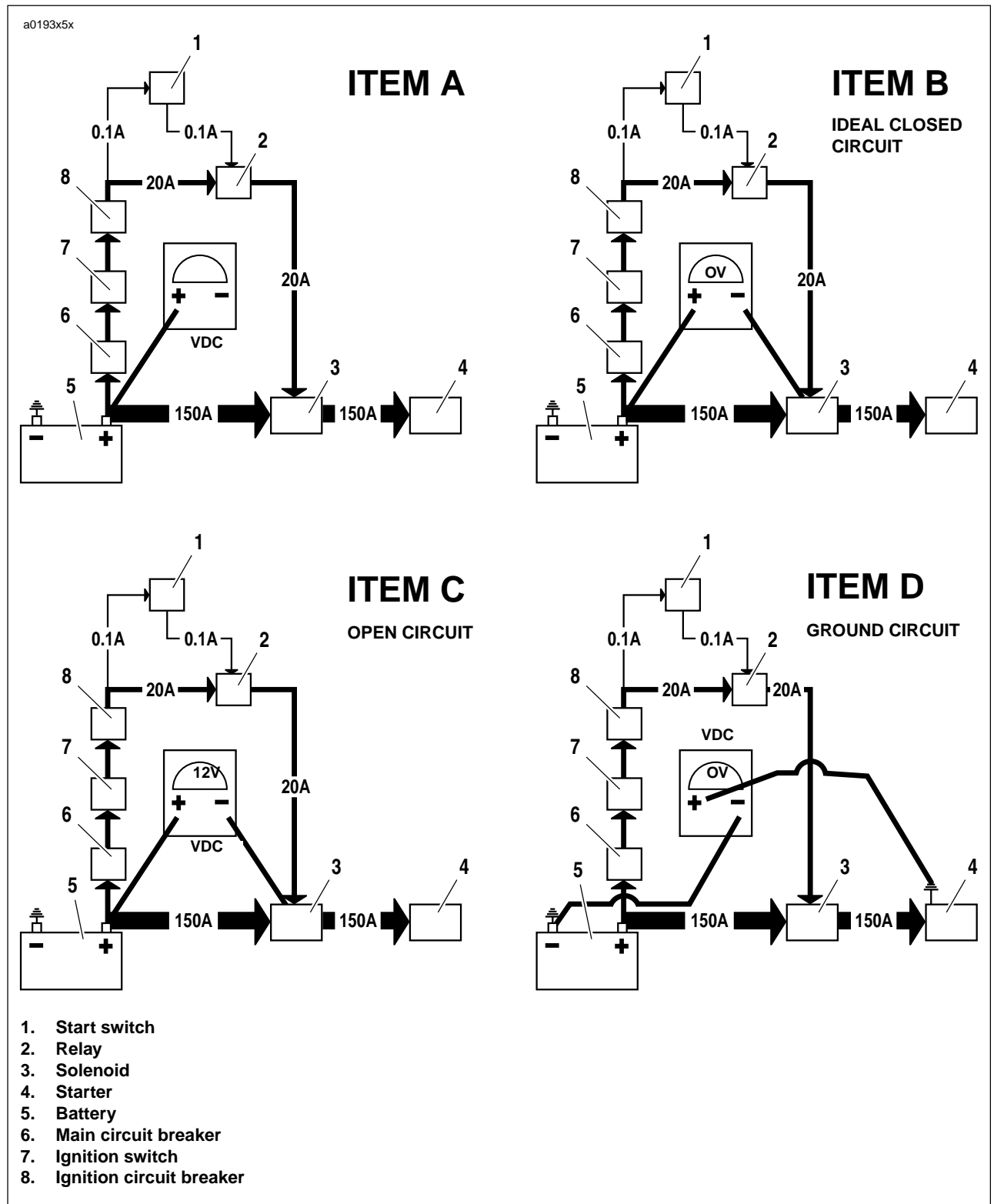


Figure 5-4. Typical Circuitry. (Refer to wiring diagrams for more information.)

GENERAL

The troubleshooting table beginning on [page 5-4](#) contains detailed procedures to solve and correct problems. Follow the [5.3 STARTER DIAGNOSTICS](#) diagram to diagnose starting system problems. The [VOLTAGE DROPS](#) procedure below will help you to locate poor connections or components with excessive voltage drops.

VOLTAGE DROPS

Check the integrity of all wiring, switches, circuit breakers and connectors between the source and destination.

The voltage drop test measures the difference in potential or the actual voltage dropped between the source and destination.

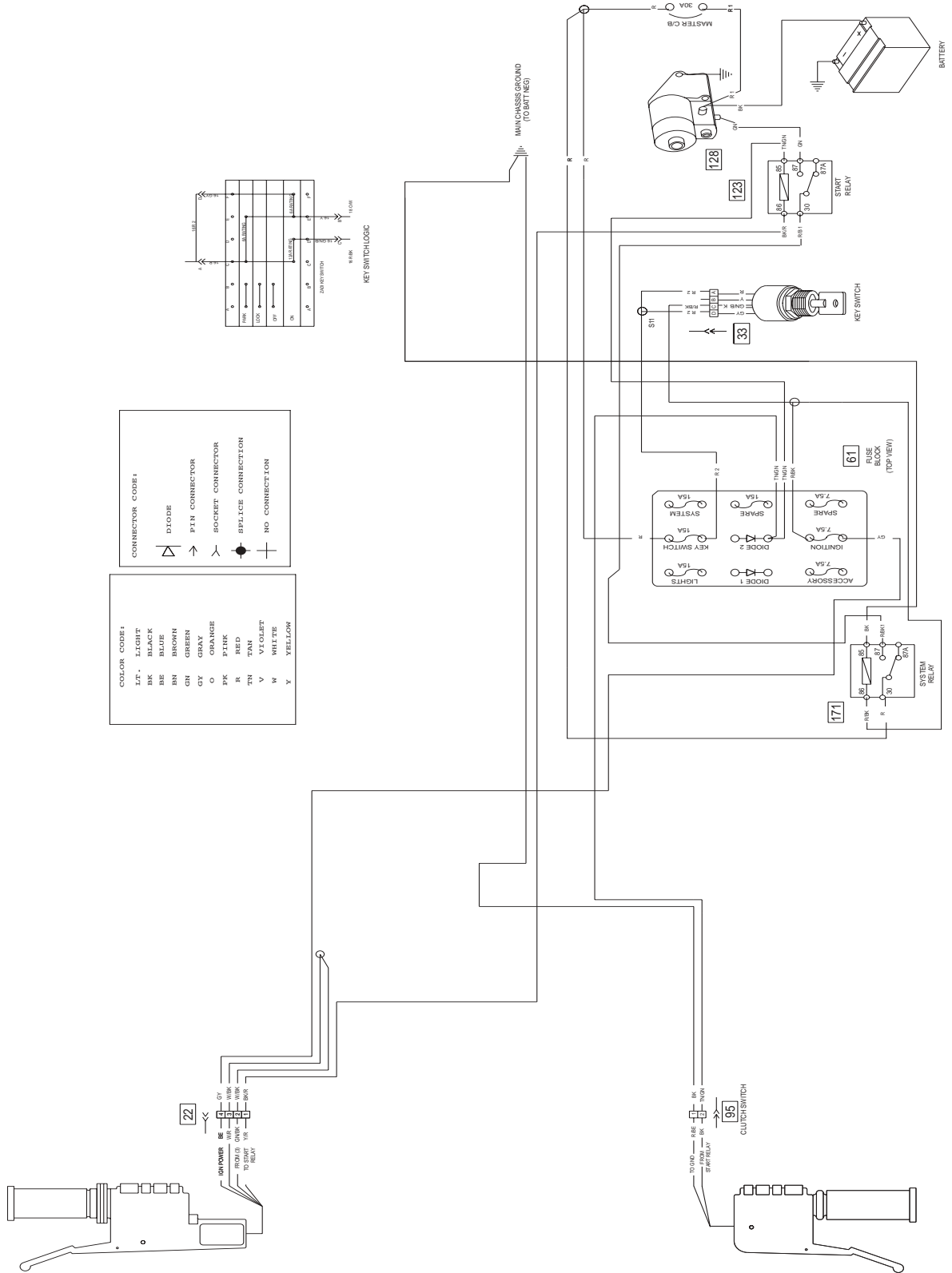
1. See [ITEM A](#) in [Figure 5-4](#). Attach your red meter lead to the most positive part of the circuit, which in this case would be the positive post of the battery (5).
2. See [ITEM B](#) in [Figure 5-4](#). Attach the black meter lead to the final destination or component in the circuit (solenoid terminal from relay).
3. Activate the starter and observe the meter reading. The meter will read the voltage dropped or the difference in potential between the source and destination.
4. An ideal circuit's voltage drop would be 0 volts or no voltage dropped, meaning no difference in potential.
5. See [ITEM C](#) in [Figure 5-4](#). An open circuit should read 12 volts, displaying all the voltage dropped, and the entire difference in potential displayed on the meter.

NOTE

Open circuits on the ground side will read zero.

6. Typically, a good circuit will drop less than 1 volt.
7. If the voltage drop is greater, back track through the connections until the source of the potential difference is found. The benefit of doing it this way is speed.
 - a. Readings aren't as sensitive to real battery voltage.
 - b. Readings show the actual voltage dropped, not just the presence of voltage.
 - c. This tests the system as it is actually being used. It is more accurate and will display hard to find poor connections.
 - d. This approach can be used on lighting circuits, ignition circuits, etc. Start from most positive and go to most negative (the destination or component).
8. See [ITEM D](#) in [Figure 5-4](#). The negative or ground circuit can be checked as well.
 - a. Place the negative lead on the most negative part of the circuit (or the negative battery post). Remember, there is nothing more negative than the negative post of the battery.
 - b. Place the positive lead to the ground you wish to check.
 - c. Activate the circuit. This will allow you to read the potential difference or voltage dropped on the negative or ground circuit. This technique is very effective for identifying poor grounds due to powdered paint. Even the slightest connection may cause an ohmmeter to give a good reading. However, when sufficient current is passed through, the resistance caused by the powdered paint will cause a voltage drop or potential difference in the ground circuit.

a0194x5x



COLOR CODE:

LT.	LIGHT
BK.	BLACK
BE.	BLUE
BN.	BROWN
GN.	GREEN
GY.	GRAY
O.	ORANGE
PK.	PINK
R.	RED
TN.	TAN
V.	VIOLET
W.	WHITE
Y.	YELLOW

CONNECTOR CODE:

△	DIODE
→	PLIN CONNECTOR
⌒	SOCKET CONNECTOR
●	SPLICE CONNECTION
+	NO CONNECTION

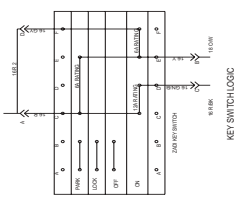


Figure 5-5. Electrical Starting System Circuit

“ON-MOTORCYCLE” TESTS

Starter Relay Test

1. See [Figure 5-6](#). Locate starter relay. The relay is attached to relay connector [123] located to the right of the battery underneath the seat.

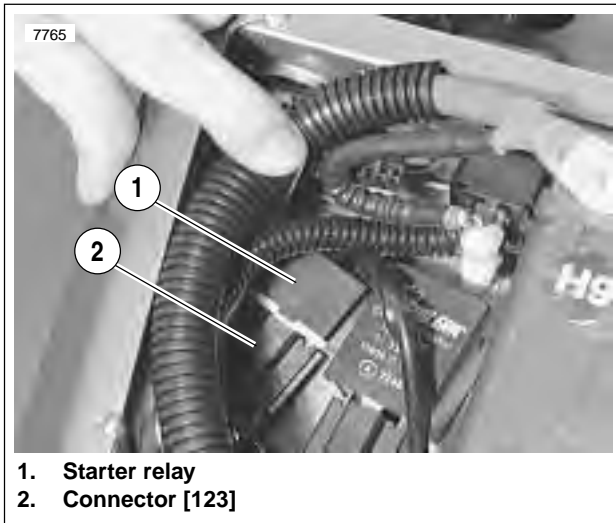


Figure 5-6. Starter Relay Connector

2. To test relay, proceed to Step 3. If installing a **new** starter relay, remove old relay. Install relay connector [123] to **new** relay.

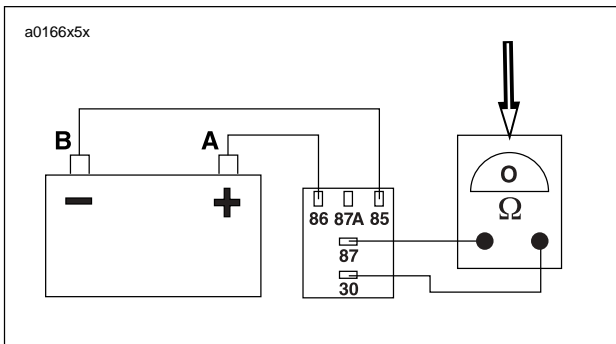


Figure 5-7. Starter Relay Test with Ohmmeter

3. See [Figure 5-7](#). Obtain a 12 volt battery and a continuity tester or ohmmeter.
 - a. Pull relay from relay block.
 - b. Connect positive battery lead to the 86 terminal.
 - c. Connect negative battery lead to the 85 terminal to energize relay.
 - d. Check for continuity between the 30 and 87 terminals. A good relay shows continuity (continuity tester lamp “on” or a zero ohm reading on the ohmmeter). A malfunctioning relay will not show continuity and must be replaced.

4. If starter relay is functioning properly, proceed to [STARTER CURRENT DRAW TEST](#).

Starter Current Draw Test

NOTES

- Engine temperature should be stable and at room temperature.
- Battery should be fully charged.

See [Figure 5-8](#). Check starter current draw with an induction ammeter before disconnecting battery. Proceed as follows:

1. Verify that transmission is in neutral. Disconnect spark plug wires from spark plug terminals.
2. Clamp induction ammeter over positive battery cable next to starter.
3. With ignition key switch ON, turn engine over by pressing starter switch while taking a reading on the ammeter. Disregard initial high current reading which is normal when engine is first turned over.
 - a. Typical starter current draw will range between 80-130 amperes.
 - b. If starter current draw exceeds 130 amperes, then the problem may be in the starter or starter drive. Remove starter for further tests. See [5.7 STARTER](#).

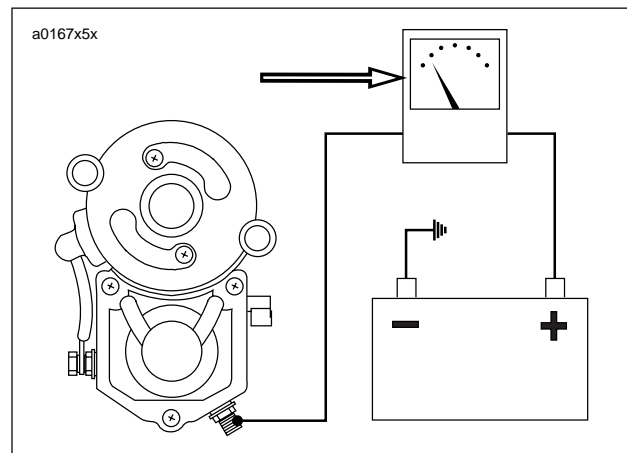


Figure 5-8. Starter Draw Test with Induction Ammeter

REMOVAL

1. Remove seat. See 2.28 SEAT.

⚠ WARNING

To prevent accidental vehicle start-up, which could cause death or serious injury, disconnect negative (-) battery cable before proceeding. (00048a)

⚠ WARNING

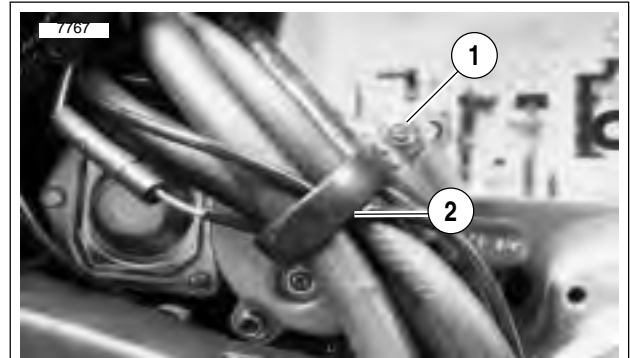
Disconnect negative (-) battery cable first. If positive (+) cable should contact ground with negative (-) cable connected, the resulting sparks can cause a battery explosion, which could result in death or serious injury. (00049a)

2. Disconnect battery cables from battery, negative cable first.
3. Remove air cleaner. See 1.17 AIR CLEANER.
4. Remove left side footpeg support bracket and primary cover. See 2.21 FOOTPEGS AND FOOTPEG SUPPORT BRACKETS.
5. See Figure 5-9. Remove locknut and clamp that secure oil hoses on right side of motorcycle.
6. Push hoses to either side to allow access to starter.
7. See Figure 5-10. Remove both starter mounting bolts and washers.

NOTE

A ball hex driver may be required to gain access to the starter mounting bolts.

8. See Figure 5-11. Remove positive battery cable from solenoid.
 - a. Remove protective boot if present.
 - b. Remove nut with washer (metric) that attaches positive battery cable to post.
 - c. Remove positive battery cable ring terminal.
 - d. Detach solenoid connector [128].
9. Remove starter and gasket.



1. Locknut
2. Clamp

Figure 5-9. Oil Hose Clamp

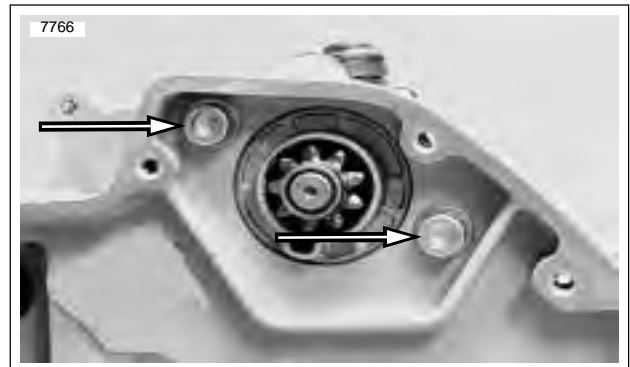
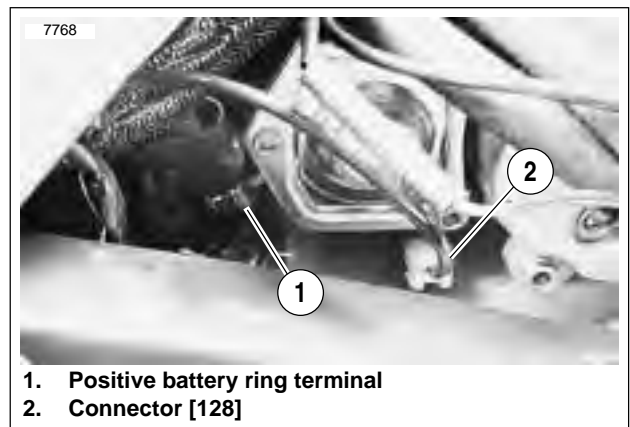


Figure 5-10. Starter Mounting Bolts and Washers (Primary Side)



1. Positive battery ring terminal
2. Connector [128]

Figure 5-11. Starter Wires

TESTING ASSEMBLED STARTER

Free Running Current Draw Test

- Place starter in vise, using a clean shop towel to prevent scratches or other damage.

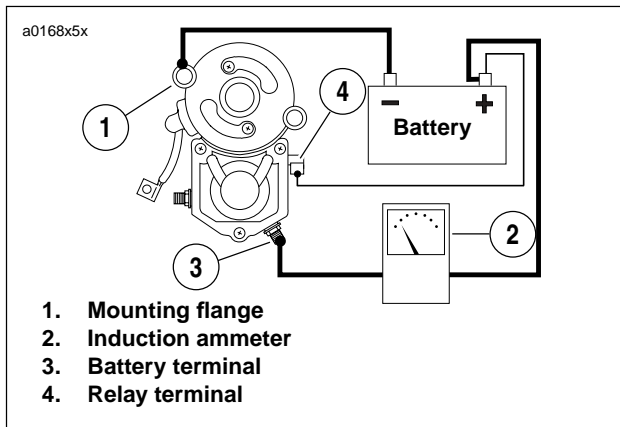


Figure 5-12. Free Running Current Draw Test

- See Figure 5-12. Attach one heavy jumper cable (6 gauge minimum).
 - To the starter mounting flange (1).
 - To the negative (-) terminal of a fully charged battery.
- Connect a second heavy jumper cable (6 gauge minimum).
 - To the positive (+) terminal of the battery.
 - To an inductive ammeter (2). Continue on to the battery terminal (3) on the starter solenoid.
- Connect a smaller jumper cable (14 gauge minimum).
 - To the positive (+) terminal of the battery.
 - To the solenoid relay terminal (4).
- Check ammeter reading.
 - Ammeter should show 90 amps maximum. If reading is higher, disassemble starter for inspection.
 - If starter current draw on vehicle was over 130 amps and this test was within specification, there may be a problem with engine or primary drive.

Starter Solenoid

NOTE

Do not disassemble solenoid. Before testing, disconnect field wire from motor terminal as shown in Figure 5-13.

IMPORTANT NOTE

Each test should be performed for only 3-5 seconds to prevent damage to solenoid.

NOTE

The solenoid Pull-in, Hold-in, and Return tests must be performed together in one continuous operation. Conduct all three tests one after the other in the sequence given without interruption.

Solenoid Pull-in Test

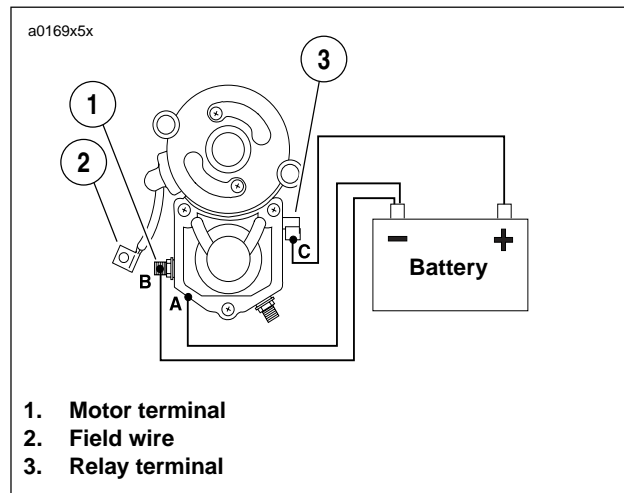


Figure 5-13. Pull-In Test

- See Figure 5-13. Using a 12 volt battery, connect three separate test leads as follows:
 - Solenoid housing to negative battery post.
 - Solenoid motor terminal to negative battery post.
 - Solenoid relay terminal to positive battery post.
- Observe starter pinion.
 - If starter pinion pulls in strongly, solenoid is working properly.
 - If starter pinion does not pull in, replace the solenoid.

Solenoid Hold-in Test

1. See [Figure 5-14](#). With test leads still connected in the manner specified in the previous [SOLENOID PULL-IN TEST](#), **disconnect solenoid motor terminal/battery negative test lead (B) at negative battery post only; reconnect loose end of this test lead to positive battery post instead.**

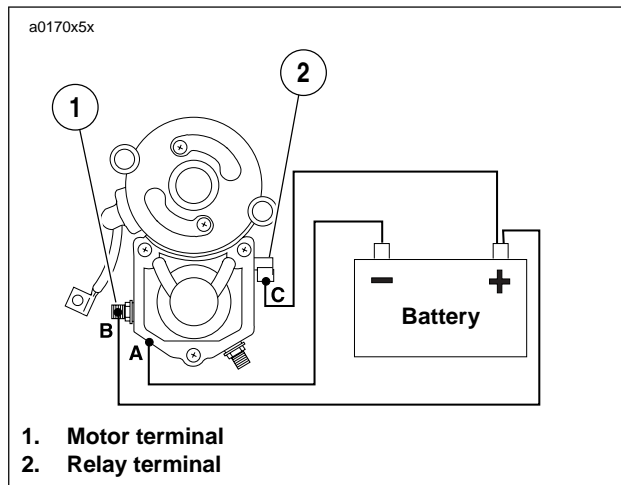


Figure 5-14. Hold-In Test

2. Observe starter pinion.
 - a. If starter pinion remains in pull-in position, solenoid is working properly.
 - b. If starter pinion does not remain in pull-in position, replace the solenoid.

Solenoid Return Test

1. See [Figure 5-15](#). With test leads still connected in the manner specified at the end of the previous [SOLENOID HOLD-IN TEST](#), **disconnect solenoid relay terminal/positive battery post test lead (C) at either end.**
2. Observe starter pinion.
 - a. If starter pinion returns to its original position, solenoid is working properly.
 - b. If starter pinion does not return to its original position, replace the solenoid.

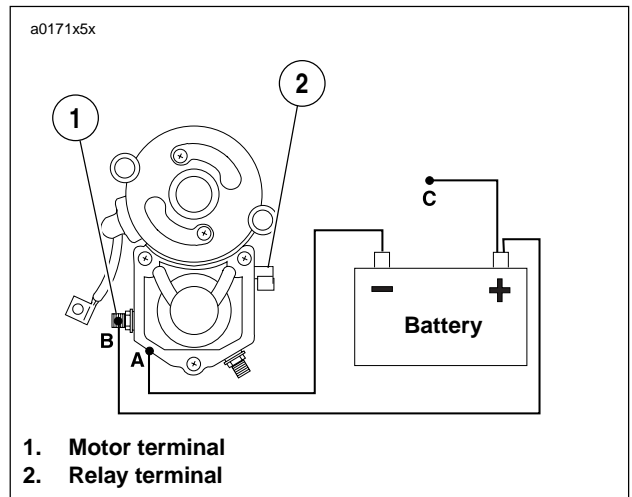


Figure 5-15. Return Test

DISASSEMBLY AND INSPECTION

1. See [Figure 5-16](#). Lift rubber boot (1). Remove field wire nut with washer (2) (metric) to detach field wire (3).

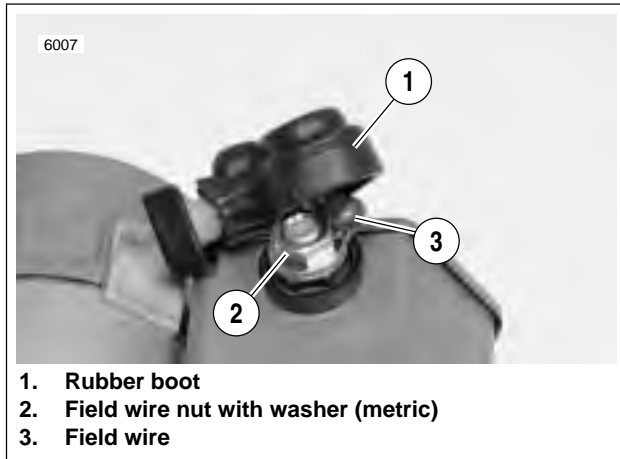


Figure 5-16. Field Wire

2. See [Figure 5-17](#). Remove both thru-bolts (1, 3).
3. Remove both end cover screws with o-rings (2) and end cover (4).

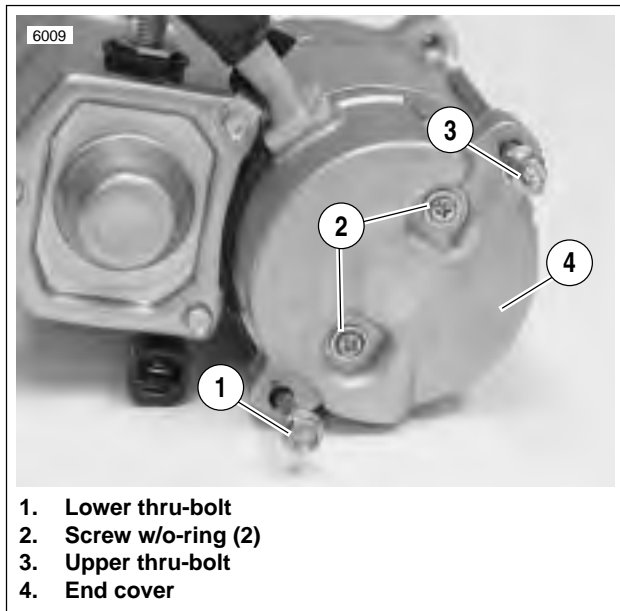


Figure 5-17. Removing the Thru-Bolts

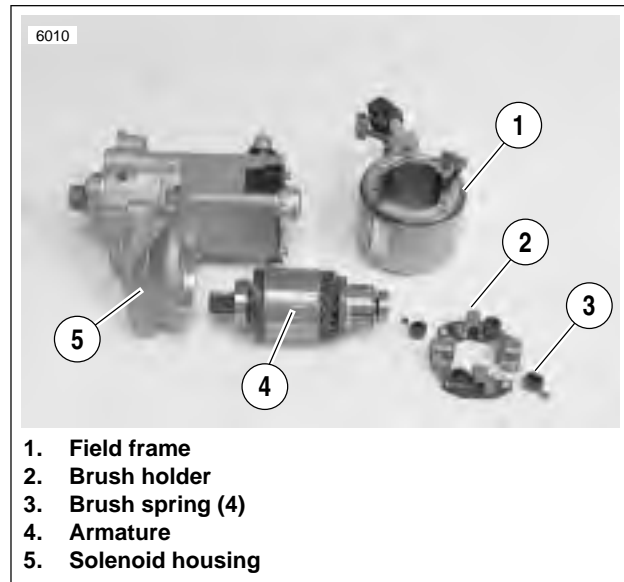


Figure 5-18. Starter Components

4. See [Figure 5-18](#). Use a wire hook to pull upward on brush springs (3), and lift brushes out of holder (2). Remove brush holder.
5. Check brush length. Replace all four brushes if length of any one brush is less than 0.433 in. (11.0 mm).

NOTE

*Brushes not available separately. Purchase a **new** field frame (1) and brush holder (2) to replace brushes.*

6. Remove armature (4) and field frame (1).
7. Place armature in lathe or truing stand and check commutator runout and diameter.
 - a. Commutators with more than 0.016 in. (0.4 mm) of runout should be replaced or machined on a lathe.
 - b. Replace commutators when diameter is less than 1.141 in. (28.981 mm)
 - c. Check armature bearings. Replace if necessary.

IMPORTANT NOTE

Do not use sandpaper or emery cloth to remove burrs on commutator. Otherwise, abrasive grit may remain on commutator segments; this could lead to excessive brush wear. Use only the recommended crocus cloth.

8. Check depth of mica on commutator. If undercut is less than 0.008 in. (0.203 mm), use an undercutting machine to undercut the mica to 0.031 in. (0.8 mm) deep. The slots should then be cleaned to remove any dirt or copper dust.

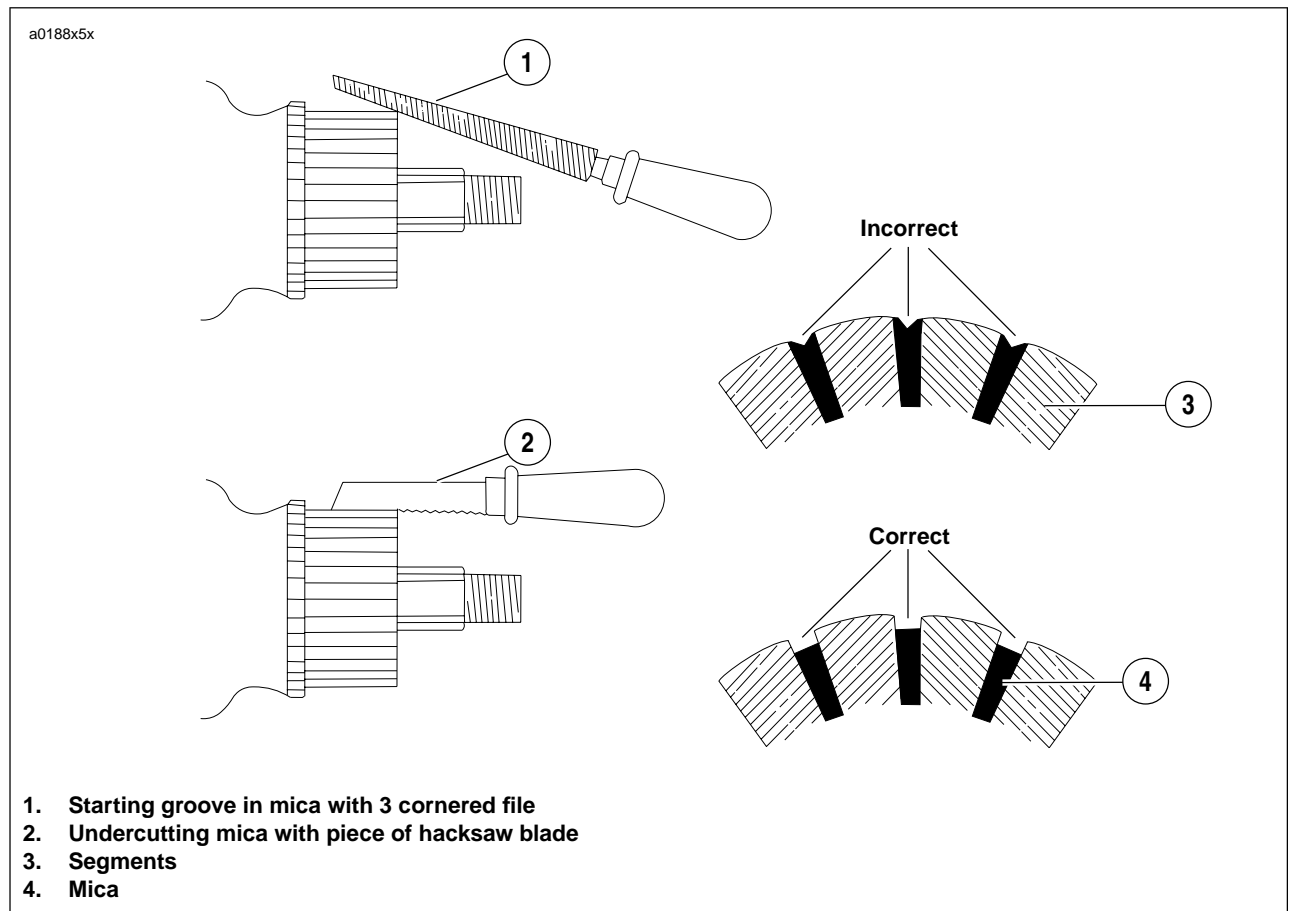


Figure 5-19. Undercutting Mica Separators

NOTES

- See [Figure 5-19](#). If an undercutting machine is not available, undercutting can be done satisfactorily using a thin hacksaw blade. After undercutting, lightly sand the commutator with crocus cloth to remove any burrs.
- See [Figure 5-19](#). Mica must not be left with a thin edge next to segments. Mica must be cut away clean between segments.

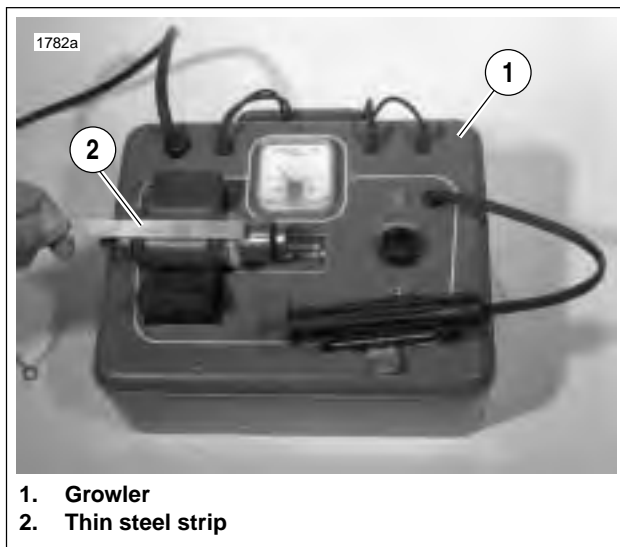


Figure 5-20. Shorted Armature Test Using Growler

9. See [Figure 5-20](#). Check for SHORTED ARMATURE with a growler.
- Place armature on growler (1).
 - Hold a thin steel strip (2) (hacksaw blade) against armature core and slowly turn armature.
 - A shorted armature will cause the steel strip to vibrate and be attracted to the core. Replace shorted armatures.



Figure 5-22. Open Armature Test

11. See [Figure 5-22](#). Check for OPEN ARMATURE with an ohmmeter or continuity tester.
- Check for continuity between all commutator segments.
 - There should be continuity (0 ohms) at all test points. No continuity at any test point indicates armature is open and must be replaced.

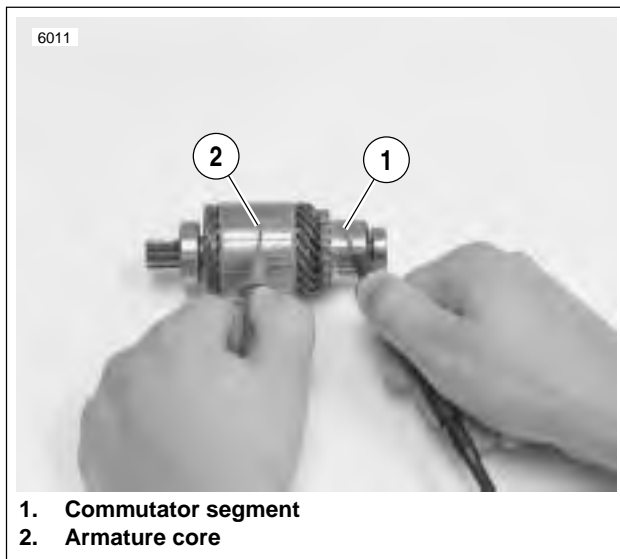


Figure 5-21. Grounded Armature Test

10. See [Figure 5-21](#). Check for a GROUNDED ARMATURE with an ohmmeter or continuity tester.
- Touch one probe to any commutator segment (1).
 - Touch the other probe to the armature core (2).
 - There should be no continuity (infinite ohms). If there is continuity, then the armature is grounded. Replace grounded armatures.

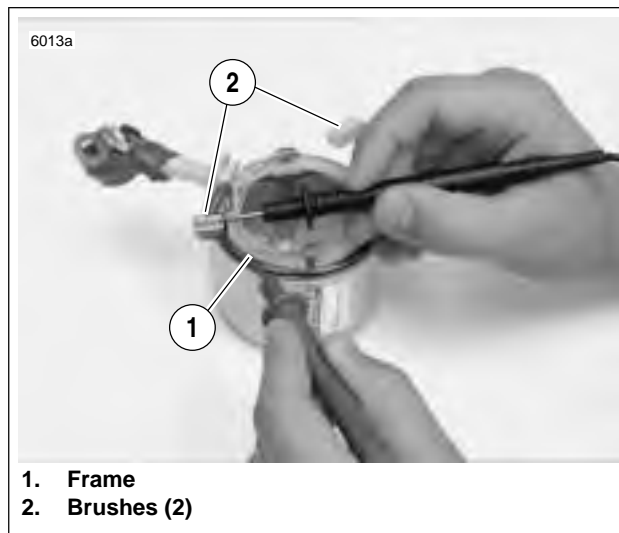


Figure 5-23. Grounded Field Test

12. See [Figure 5-23](#). Check for GROUNDED FIELD COIL with an ohmmeter or continuity tester.
- Touch one probe to the frame (1).
 - Touch the other probe to each of the brushes (2) attached to the field coil.
 - There should be no continuity (infinite ohms). If there is any continuity at either brush, then the field coil(s) are grounded and the field frame must be replaced.

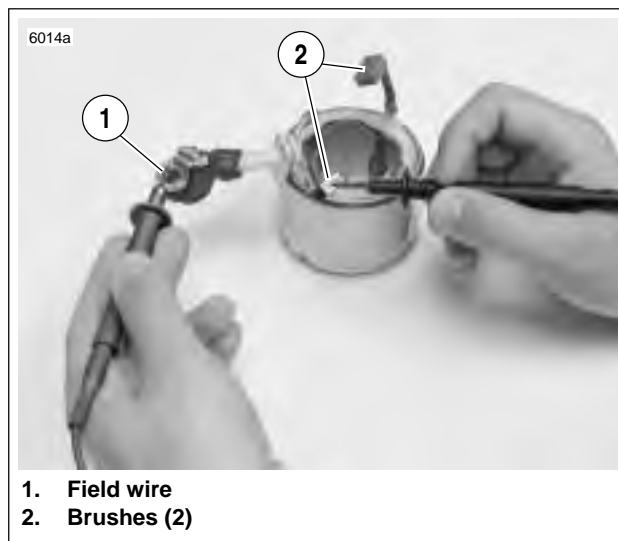


Figure 5-24. Open Field Test

13. See [Figure 5-24](#). Check for OPEN FIELD COILS with an ohmmeter or continuity tester.
- Touch one probe to the field wire (1).
 - Touch the other probe to each of the brushes attached to the field coil(s) (2).
 - There should be continuity (0 ohms). If there is no continuity at either brush, then the field coil(s) are open and the field frame must be replaced.

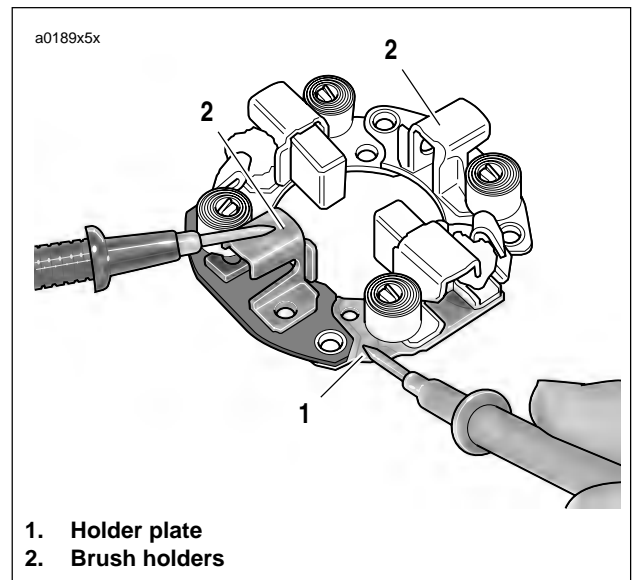
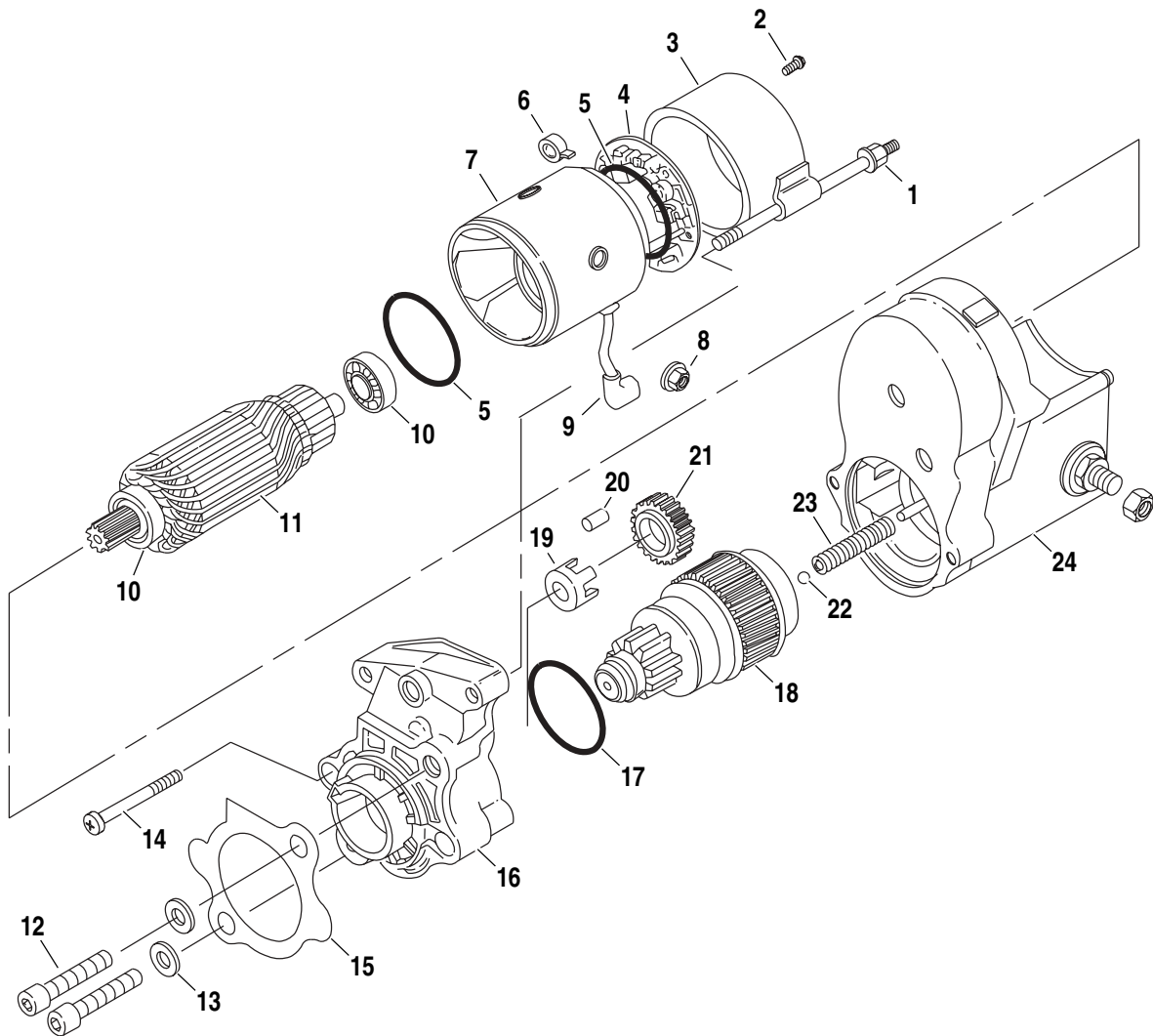


Figure 5-25. Brush Holder Insulation Test

14. See [Figure 5-25](#). Test BRUSH HOLDER INSULATION with an ohmmeter or continuity tester.
- Touch one probe to holder plate (1).
 - Touch the other probe to each of the positive (insulated) brush holders (2).
 - There should be no continuity (infinite ohms). If there is continuity at either brush holder, replace the brush holder assembly.
15. See [Figure 5-26](#). Remove two drive housing mounting screws (6). Remove drive housing (5) from solenoid housing.
16. Remove drive (1), idler gear (2), idler gear bearing (3), and o-ring (4) from drive housing (o-ring is located in drive housing groove).



- | | |
|--|---------------------------------------|
| 1. Thru-bolt (2) | 13. Washer (2) |
| 2. End cover screw and o-ring (2) | 14. Drive housing mounting bolt |
| 3. End cover | 15. Gasket |
| 4. Brush holder | 16. Drive housing |
| 5. O-ring (2) | 17. O-ring |
| 6. Brush spring (4) | 18. Drive assembly/overrunning clutch |
| 7. Field frame | 19. Idler gear bearing cage |
| 8. Field wire nut with washer (metric) | 20. Idler gear roller (5) |
| 9. Field wire | 21. Idler gear |
| 10. Armature bearing (2) | 22. Ball |
| 11. Armature | 23. Return spring |
| 12. Mounting bolt (2) | 24. Solenoid housing |

Figure 5-26. Starter Assembly

ASSEMBLY

1. See [Figure 5-26](#). Clean, inspect and lubricate drive assembly components. Lubricate parts with high temperature grease, such as LUBRIPLATE 110.
2. See [Figure 5-26](#). When installing drive assembly components, open end of idler bearing cage (19) faces toward solenoid.
3. When installing drive housing (16) to solenoid housing (24), use **new** o-ring (17). Be sure to install return spring (23) and ball (22).
4. Lubricate armature bearings (10) with high temperature grease, such as LUBRIPLATE 110. Install armature (11) and field frame (7) to solenoid housing (24).
5. Install brushes and brush holder (4).
6. Install o-rings (5). Attach end cover (3) with end cover screws and o-rings (2).
7. Install thru-bolts (1).
8. Attach field wire (9) to solenoid housing (24) with field wire nut and washer (8) (metric). Replace rubber boot.

INSTALLATION

1. Install starter and starter gasket from the right side.

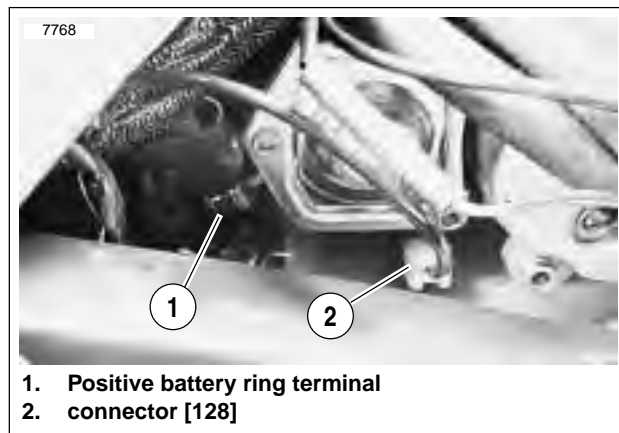


Figure 5-27. Starter Wires

2. See [Figure 5-27](#). Connect wiring to starter.
 - a. Connect solenoid wire (2).
 - b. Attach positive battery cable ring terminal (1) and install nut with washer (1) (metric). Tighten to 80-100 **in-lbs** (9-11 Nm).
 - c. Replace protective boot.

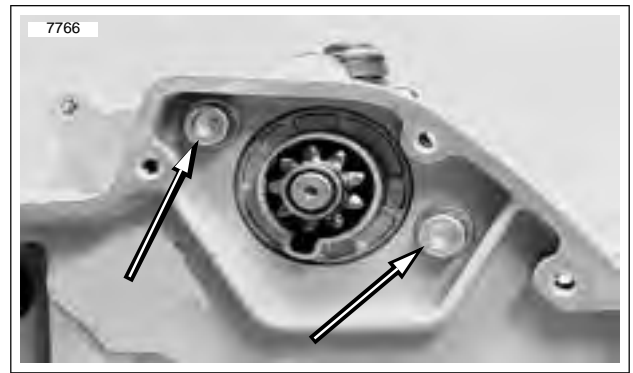


Figure 5-28. Starter Mounting Bolts and Washers (Primary Side)

3. See [Figure 5-28](#). Install both starter mounting bolts and washers. Tighten to 13-20 ft-lbs (18-27 Nm).
4. Position oil hoses in clamp and install clamp to through bolt with **new** locknut. Make sure hoses are not kinked or restricted.
5. Install primary cover. See [6.2 PRIMARY CHAIN](#).
6. Fill transmission to proper level with fresh lubricant. See [1.10 TRANSMISSION/PRIMARY FLUID](#).
7. Install left side footrest support assembly. See [2.21 FOOTPEGS AND FOOTPEG SUPPORT BRACKETS](#).
8. Install air cleaner. See [1.17 AIR CLEANER](#).

⚠ WARNING

Connect positive (+) battery cable first. If positive (+) cable should contact ground with negative (-) cable connected, the resulting sparks can cause a battery explosion, which could result in death or serious injury. (00068a)

9. Connect battery cables, positive cable first. Tighten terminal hardware to 72-96 in-lbs (8-11 Nm).

⚠ WARNING

After installing seat, pull upward on front of seat to be sure it is in locked position. While riding, a loose seat can shift causing loss of control, which could result in death or serious injury. (00070a)]

10. Install seat. See [2.28 SEAT](#).

GENERAL

IMPORTANT NOTE

See [Figure 5-29](#). Do not tighten nut (7) without removing items 1-5. Movement will cause damage to the contact.

The starter solenoid is a switch that is designed to open and close the starting circuit electromagnetically. The switch consists of contacts and a winding around a hollow cylinder containing a movable plunger.

DISASSEMBLY

1. See [Figure 5-29](#). Remove screws (1) and clip (2).
2. Remove cover (3) and gasket (4). Discard gasket.
3. Remove plunger (5) from solenoid housing (6).

ASSEMBLY

1. See [Figure 5-29](#). Replace wire connection hardware as necessary.
2. Install plunger (5) in solenoid housing (6).
3. Install **new** gasket (4) onto cover (3).
4. Position cover with gasket onto solenoid housing. Install clip (2) and screws (1).

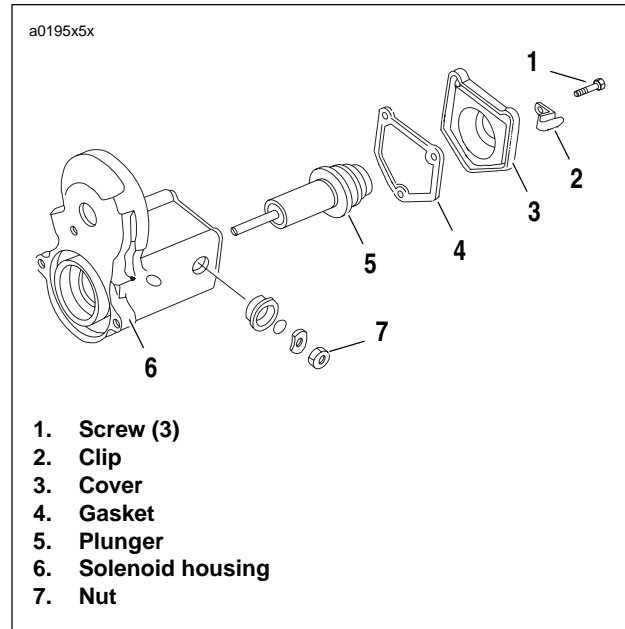


Figure 5-29. Starter Solenoid

[Table Of Contents](#)

DRIVE/TRANSMISSION 6

SUBJECT	PAGE NO.
6.1 Specifications	6-1
6.2 Primary Chain	6-3
6.3 Clutch Release Mechanism	6-7
6.4 Primary Drive/Clutch	6-9
6.5 Transmission	6-17
6.6 Transmission Case	6-18
6.7 Transmission Disassembly	6-20
6.8 Transmission Assembly	6-25
6.9 Main Drive Gear	6-29
6.10 Right Transmission Case Bearings	6-32
6.11 Left Crankcase Bearings	6-34
6.12 Transmission Installation	6-36
6.13 Shifter Pawl Adjustment	6-38
6.14 Transmission Sprocket	6-40

1. 1.

1.

NOTE

Service wear limits are given as a guideline for measuring components that are not new. For measurement specifications not given under SERVICE WEAR LIMITS, see NEW COMPONENTS.

Table 6-1. Primary Drive Specifications

ITEM	NEW COMPONENTS	SERVICE WEAR LIMITS
PRIMARY DRIVE ENGINE-TO-TRANSMISSION		
Engine sprocket – number of teeth	35	N/A
Clutch sprocket – number of teeth	56	N/A
Ratio*	1.60:1	N/A

Table 6-2. Final Drive Specifications

ITEM	NEW COMPONENTS	SERVICE WEAR LIMITS
FINAL DRIVE (TRANSMISSION-TO-REAR WHEEL)		
Transmission sprocket – number of teeth	27	N/A
Rear wheel sprocket – number of teeth	80	Replace at 15,000 mi (24,000 km)
Secondary drive belt – number of teeth	139	Replace at 15,000 mi (24,000 km)
Ratio	2.96:1	N/A

Table 6-3. Transmission Specifications

ITEM	NEW COMPONENTS	SERVICE WEAR LIMITS
TRANSMISSION		
Primary drive / transmission lubricant capacity	32 fl. oz. (946 ml)	N/A
OVERALL GEAR RATIOS**		
First gear (low)	12.74	N/A
Second gear	8.77	N/A
Third gear	6.79	N/A
Fourth gear	5.60	N/A
Fifth gear (high)	4.74	N/A

* Internal gear ratios indicate number of mainshaft revolutions required to drive output sprocket one revolution.

** Overall gear ratios indicate number of engine revolutions required to drive rear wheel one revolution.

Table 6-4. Clutch Specifications

WET CLUTCH/MULTIPLE DISC		
CLUTCH PLATE THICKNESS	NEW COMPONENTS	SERVICE WEAR LIMITS
ITEM		
Friction plate (fiber) (in.)	0.0866 + 0.0031	N/A
Friction plate (fiber) (mm)	2.200 + 0.079	N/A
Steel plate (in.)	0.0629 + 0.0020	N/A
Steel plate (mm)	1.598 + 0.051	N/A
Clutch pack (in.)	N/A	0.413 in. (minimum)
Clutch pack (mm)	N/A	(16.787)
MAXIMUM ALLOWABLE WARPAGE		
Friction plate (fiber) (in.)	N/A	0.0059
Friction plate (fiber) (mm)	N/A	0.150
Steel plate (in.)	N/A	0.0059
Steel plate (mm)	N/A	0.150

TORQUE VALUES

ITEM	TORQUE		NOTES
Battery terminal bolts	72-96 in-lbs	8-11 Nm	Page 6-6
Clutch mainshaft nut	70-80 ft-lbs	95-109 Nm	Loctite Threadlocker 271 (red), left hand threads, Page 6-15
Crankcase 1/4 in. screws	180-100 in-lbs	9.0-12.4 Nm	Loctite Threadlocker 271 (red), Page 6-36
Crankcase 5/16 in. screws	15-19 ft-lbs	20-25 Nm	Loctite Threadlocker 271 (red), Page 6-36
Engine sprocket nut	190-210 ft-lbs	258-285 Nm	Loctite Threadlocker 271 (red), Page 6-15
Magnetic drain plug	14-30 ft-lbs	19-40.7 Nm	Metric, Page 6-6
Primary chain limiting screw jam nut	20-25 ft-lbs	28-33 Nm	Page 6-5
Primary cover bolts	100-120 in-lbs	11-14 Nm	Follow torque sequence, Page 6-6
Shift lever pinch fastener	12-14 ft-lbs	16-19 Nm	Page 6-6
Shifter shaft assembly locknuts	90-110 in-lbs	10-12 Nm	Bottom nut first, same torque for top, Page 6-38
Transmission sprocket nut	See NOTES	See NOTES	Loctite Threadlocker 271 (red), left hand threads, special torque turn method, Page 6-41
Transmission sprocket screws	90-110 in-lbs	10-12 Nm	Replace after 3 removals, Page 6-41

GENERAL

An opening between the primary drive and transmission compartments allows the same lubricant supply to lubricate moving parts in both compartments.

Since the primary chain runs in lubricant, little service will be required other than checking lubricant level and chain tension. If, through hard usage, the primary chain does become worn, it must be replaced. Remove and install the chain following the procedure under [6.4 PRIMARY DRIVE/CLUTCH](#).

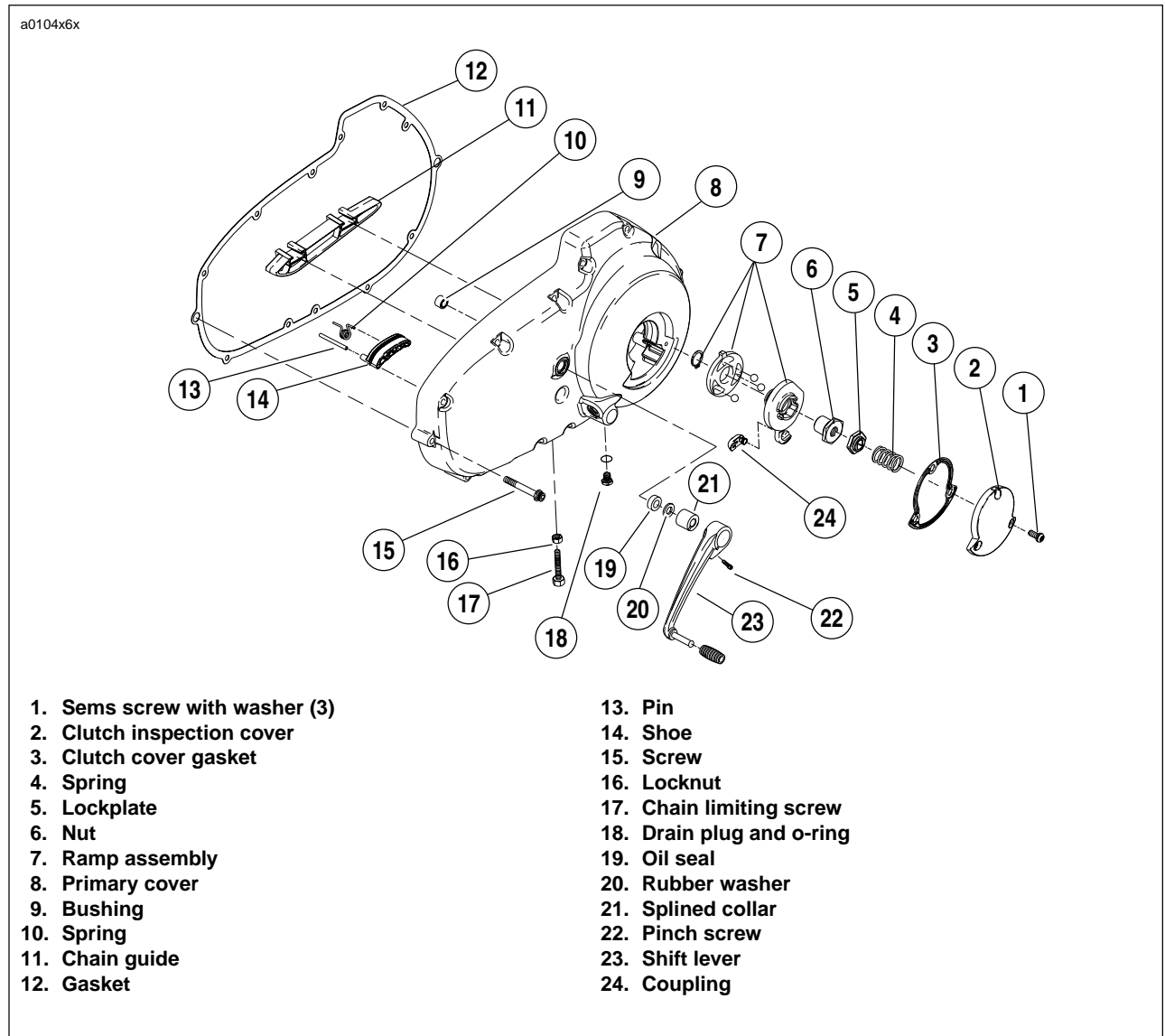


Figure 6-1. Primary Cover and Shifter Assembly

REMOVAL

Primary Cover

1. Remove seat. See [2.28 SEAT](#).

⚠ WARNING

To prevent accidental vehicle start-up, which could cause death or serious injury, disconnect negative (-) battery cable before proceeding. (00048a)

⚠ WARNING

Disconnect negative (-) battery cable first. If positive (+) cable should contact ground with negative (-) cable connected, the resulting sparks can cause a battery explosion, which could result in death or serious injury. (00049a)

2. Disconnect negative battery cable from battery.
3. See [Figure 6-1](#). Place a drain pan under the engine. Remove drain plug and drain lubricant from primary drive.
4. Remove shifter lever assembly and rubber washer. Do not scratch primary cover.
5. See [ADJUSTMENT](#) under [1.9 CLUTCH](#). Add freeplay to clutch cable.
6. See [Figure 6-2](#). Loosen locknut. Turn chain adjuster screw counterclockwise (outward).
7. Remove left foot peg support bracket. See [2.21 FOOT-PEGS AND FOOTPEG SUPPORT BRACKETS](#).
8. Remove three sems screws with washers and clutch inspection cover.
9. Remove and discard gasket from groove in primary cover.
10. Slide spring with attached hex lockplate from flats of clutch limiting screw.
11. See [Figure 6-3](#). Turn clutch adjusting screw clockwise to release ramp and coupling mechanism. As the limiting screw is turned, ramp assembly moves forward. Unscrew nut from end of limiting screw.
12. Remove hook of ramp from button to the rear of cable end coupling. Remove cable end from slot in coupling. Remove coupling and ramp assembly.
13. Remove screws which secure primary cover. Remove cover and gasket.
14. Discard gasket.
15. Remove and discard shifter lever oil seal.

Primary Chain Adjuster

1. Loosen locknut from chain limiting screw. Turn limiting screw out of threaded boss in primary cover.
2. See [Figure 6-2](#). Remove primary cover.
3. See [Figure 6-3](#). Slide shoe outward and remove.
4. Remove chain tensioner spring.

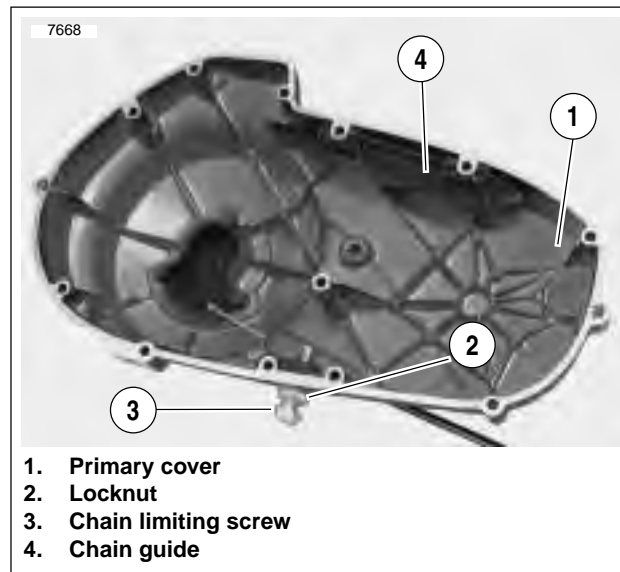


Figure 6-2. Removing Primary Chain Adjuster

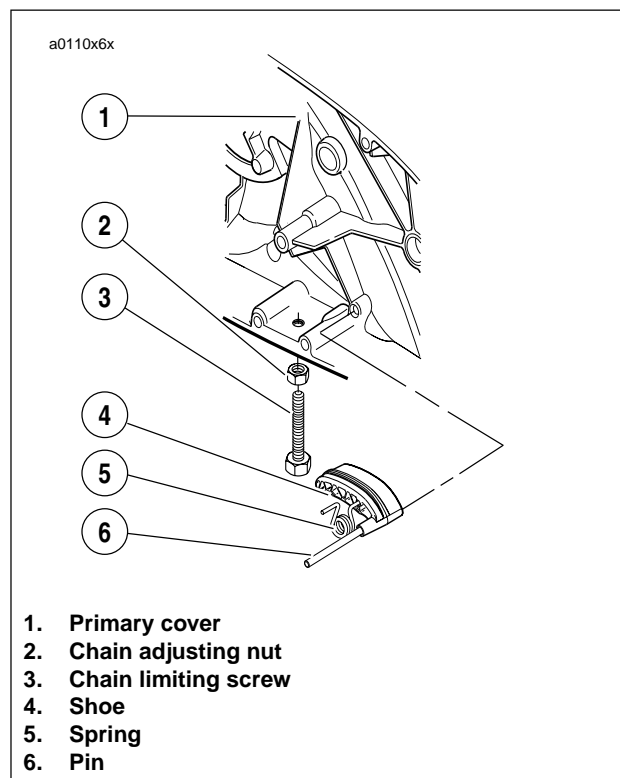


Figure 6-3. Primary Chain Adjuster

INSTALLATION

Primary Chain Adjuster

1. See [Figure 6-3](#). If shoe is badly worn, replace it.
2. Install chain tensioner spring over pin and into hole in crankcase.
3. While prying the tensioner spring down, slide shoe onto pin and tensioner spring.
4. Press shoe inward.
5. Install primary cover. See [Primary Cover](#) in [6.2 PRIMARY CHAIN](#).

Primary Chain Adjustment

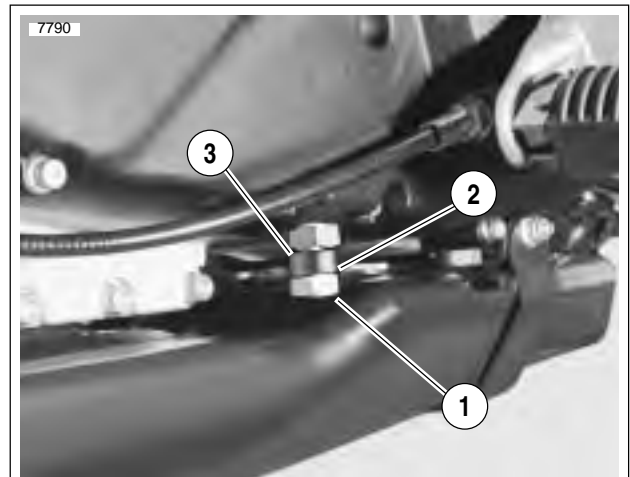
See [Figure 6-4](#). Buell Blast Models are shipped with a spacer between the primary chain limiting screw and the locknut. The spacer is used to quickly get proper adjustment during production. This spacer should be removed and discarded at the first adjustment interval.

1. See [Figure 6-5](#). Back-off jam nut (3) and chain limiting screw (1). Remove spacer (2).

IMPORTANT NOTE

Be certain to use **Inch-Pound Wrench**. Chain adjuster shoe can be damaged by excessive force.

2. See [Figure 6-6](#). Tighten chain limiting screw to 24 in-lbs (2.7 Nm).
3. Back-off chain limiting screw 3/4 turn (4 1/2 "flats").
4. Hold chain limiting screw while tightening jam nut. Tighten to 20-25 ft-lbs (28-33 Nm).



1. Chain limiting screw
2. Spacer
3. Jam nut

Figure 6-4. Adjustment Nut-with Spacer

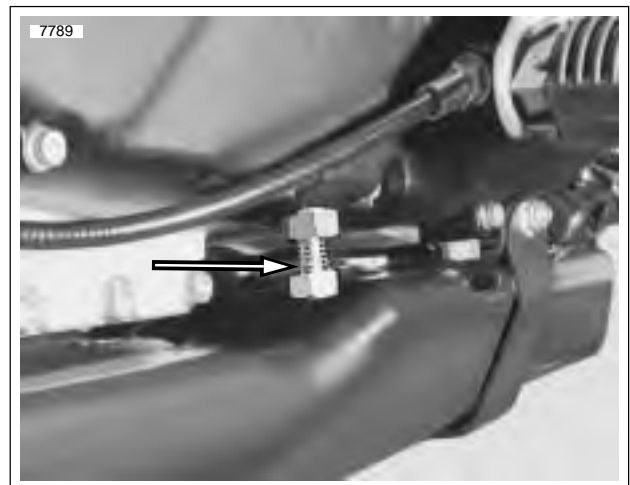


Figure 6-5. Chain Limiting Screw-without Spacer



Figure 6-6. Torquing Chain Limiting Screw

Primary Cover

1. Remove foreign material from magnetic drain plug. Apply Loctite 565 thread sealant and install plug and tighten to 14-30 ft-lbs (19-40.7 Nm).
2. Wipe gasket surface clean. Install **new** gasket on primary cover.
3. See [Figure 6-7](#). Install primary cover and gasket onto left crankcase half using mounting screws and tighten to 100-120 **in-lbs** (11-14 Nm) in sequence shown.
4. See [Figure 6-1](#). Install **new** shifter lever oil seal.
5. Fit coupling over cable end with rounded side inboard and the ramp connector button outboard. With retaining ring side of ramp assembly facing inward, place hook of ramp around coupling button and rotate assembly counterclockwise until tang on inner ramp fits in slot of primary cover.
6. Thread nut on adjustment screw until slot of screw is accessible with a screwdriver. Fit nut hex into recess of outer ramp and turn adjustment screw counterclockwise.
7. Adjust clutch. See [ADJUSTMENT](#) under [1.9 CLUTCH](#).
8. Adjust primary chain tension. See [6.2 PRIMARY CHAIN](#).
9. Fill transmission to proper level with fresh lubricant. See [TRANSMISSION](#) under section [1.10 TRANSMISSION/PRIMARY FLUID](#).
10. Install clutch inspection cover with **new** gasket and three sems screws with washers. Tighten screws in a cross-wise pattern to 84-108 **in-lbs** (10-12 Nm).
11. See [Figure 6-1](#). Install rubber washer and shifter lever assembly and tighten pinch screw to 12-14 ft-lbs (16-19 Nm)
12. Install left footpeg support bracket. See [2.21 FOOTPEGS AND FOOTPEG SUPPORT BRACKETS](#).

WARNING

Connect positive (+) battery cable first. If positive (+) cable should contact ground with negative (-) cable connected, the resulting sparks can cause a battery explosion, which could result in death or serious injury. (00068a)

13. Connect negative battery cable to battery terminal. Tighten fastener to 72-96 **in-lbs** (8-11 Nm).

WARNING

After installing seat, pull upward on front of seat to be sure it is in locked position. While riding, a loose seat can shift causing loss of control, which could result in death or serious injury. (00070a)

14. Install seat. See [2.28 SEAT](#).

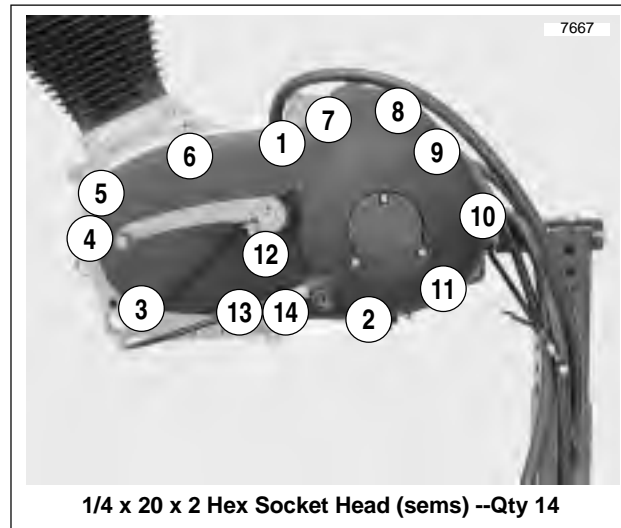


Figure 6-7. Primary Cover Tightening Sequence

DISASSEMBLY

NOTE

For clutch adjustment procedure, See 1.9 CLUTCH.

1. Remove seat. See 2.28 SEAT.

WARNING

To prevent accidental vehicle start-up, which could cause death or serious injury, disconnect negative (-) battery cable before proceeding. (00048a)

2. Disconnect negative battery cable.
3. Pull clutch cable ferrule (end of cable housing) away from clutch hand lever bracket. Gap between ferrule and bracket should be 0.0625-0.125 (1.6-3.2 mm). Adjust freeplay by turning cable adjuster.
4. Remove left footpeg support bracket. See 2.21 FOOTPEGS AND FOOTPEG SUPPORT BRACKETS.
5. See Figure 6-8. Remove three sems screws with washers (1) and clutch inspection cover (2).

6. Slide spring (4) with attached screw lockplate (5) from flats of adjusting screw.
7. Turn adjusting screw clockwise to release ramp (7) and coupling mechanism (20). As the adjusting screw is turned, ramp assembly moves forward. Unscrew nut (6) from end of adjusting screw.

CLEANING AND INSPECTION

1. Thoroughly clean all parts in cleaning solvent.
2. See Figure 6-8. Inspect three balls of release mechanism and ball socket surfaces of inner and outer ramps for wear, pitting, surface breakdown and other damage. Replace parts as necessary.
3. Check hub fit of inner and outer ramps. Replace ramps if excessively worn.
4. Check clutch cable for frayed or worn ends. Replace cable if damaged or worn.
5. Change or add transmission fluid if necessary. See 1.10 TRANSMISSION/PRIMARY FLUID.

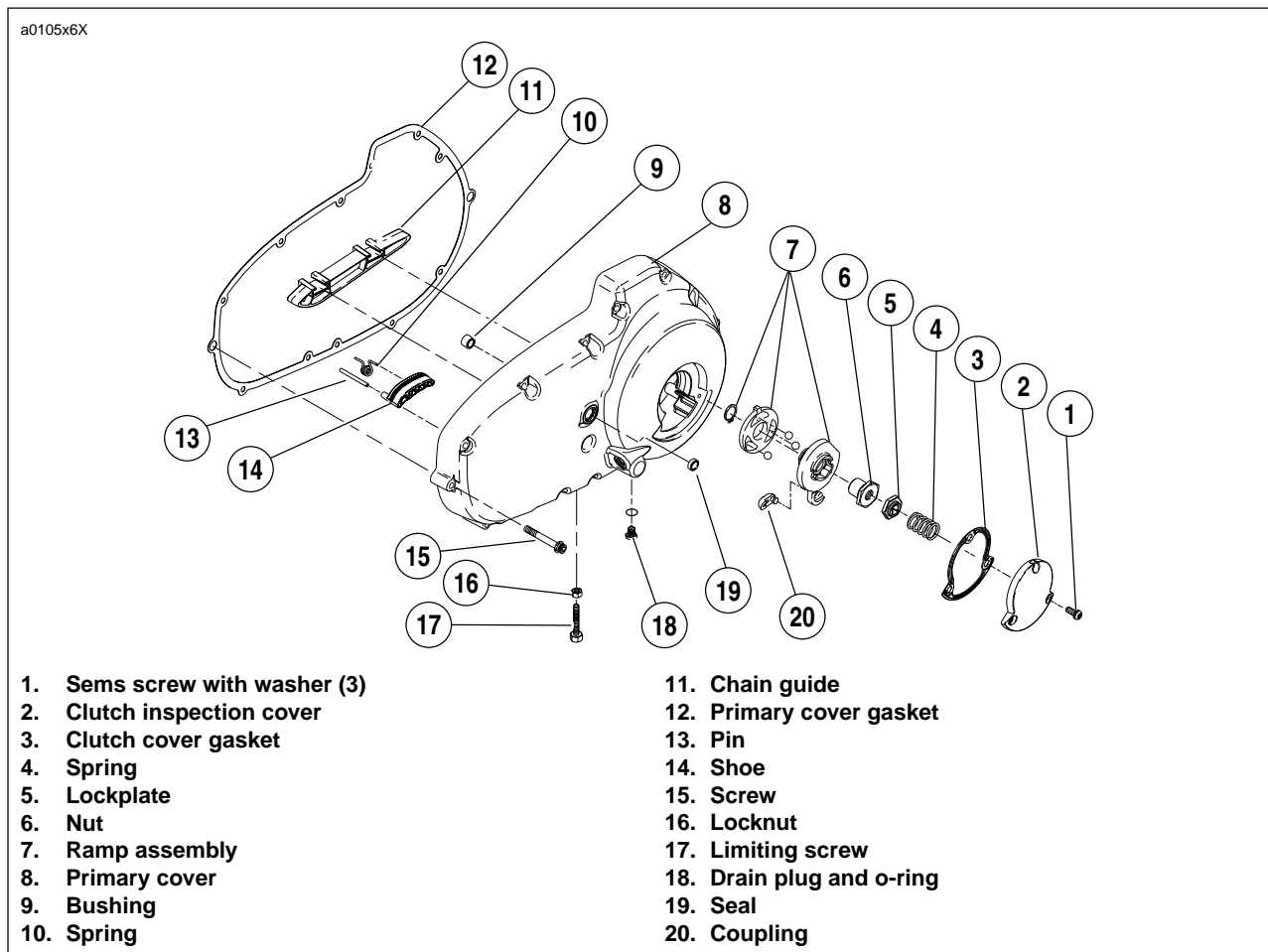


Figure 6-8. Clutch Release Mechanism

ASSEMBLY

1. See [Figure 6-9](#). Assemble inner and outer ramp.
 - a. Apply multi-purpose grease to balls and ramps.
 - b. Insert balls in sockets of outer ramp.
 - c. Install inner ramp on hub of outer ramp with tang 180° from hook of outer ramp.
 - d. Install **new** retaining ring in groove of outer ramp hub.
2. See [Figure 6-10](#). Install ramp assembly.
 - a. Fit coupling over cable end with rounded side inboard, the ramp connector button outboard.
 - b. With retaining ring side of ramp assembly facing inward, place hook of ramp around coupling button.
 - c. Rotate assembly counterclockwise until tang on inner ramp fits in slot of primary cover.
3. Secure assembly in place.
 - a. Thread nut on adjusting screw until slot of screw is accessible with a screwdriver.
 - b. Turn adjusting screw counterclockwise until resistance is felt.
 - c. Adjust clutch release mechanism. See [1.9 CLUTCH](#).
 - d. Fit nut hex into recess of outer ramp.
4. Install left footpeg support bracket. See [2.21 FOOTPEGS AND FOOTPEG SUPPORT BRACKETS](#).

WARNING

Connect positive (+) battery cable first. If positive (+) cable should contact ground with negative (-) cable connected, the resulting sparks can cause a battery explosion, which could result in death or serious injury. (00068a)

5. Connect negative battery cable to battery terminal. Tighten fastener to 72-96 in-lbs (8-11 Nm).

WARNING

After installing seat, pull upward on front of seat to be sure it is in locked position. While riding, a loose seat can shift causing loss of control, which could result in death or serious injury. (00070a)

6. Install seat. See [2.28 SEAT](#).

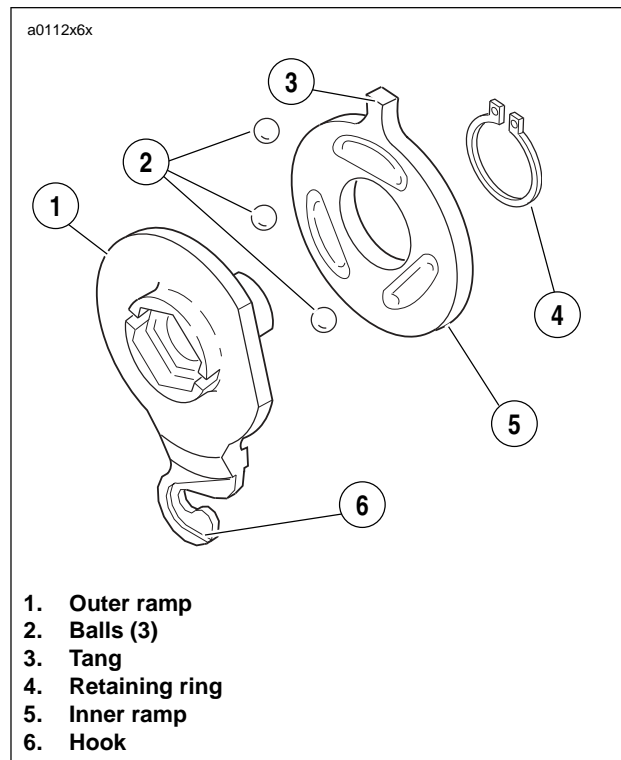


Figure 6-9. Inner & Outer Ramp

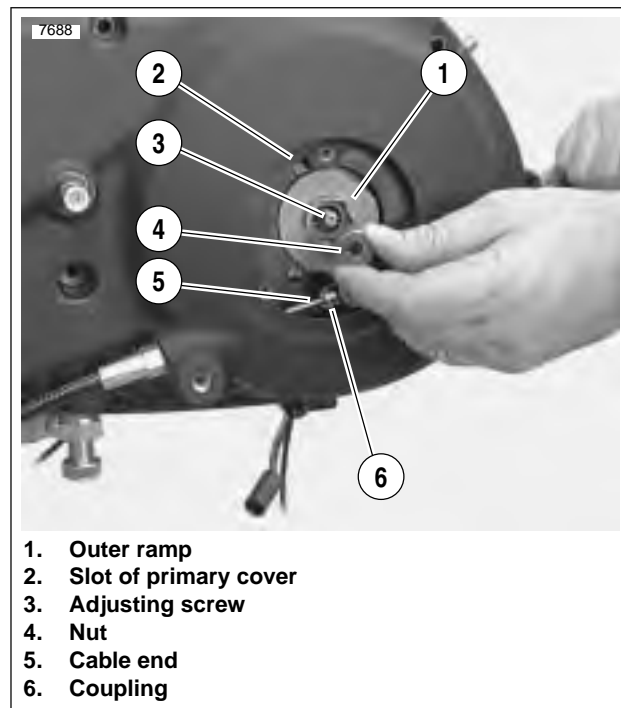


Figure 6-10. Nut & Outer Ramp

GENERAL

The purpose of the clutch is to smoothly disengage and engage the engine from the rear wheel for starting, stopping and shifting gears.

See Figure 6-11. The clutch is a wet, multiple-disc clutch with five steel plates and five fiber (friction) plates stacked alternately in the clutch shell. The order of plate assembly, from inboard to outboard, is as follows:

St - F - St - F - St - F - St - F - St - F

(St = Steel plate, F = Fiber plate)

The fiber plates (clutch driving plates) are keyed to the clutch shell, which is driven by the engine through the primary chain. The steel plates (clutch driven plates) and the centrally located spring plate (also a clutch driven plate) are keyed to the clutch hub, which drives the rear wheel through the transmission and secondary drive belt.

When the clutch is engaged (clutch lever released), the diaphragm spring applies strong inward force against the pressure plate. The pressure plate then presses the clutch plates together, allowing no slippage between the plates and causing the plates to turn as a single unit. The result is that the rotational force of the clutch shell is fully transmitted through the "locked" clutch plates to the clutch hub. As long as the transmission is set in a forward gear, power from the engine will be transmitted to the rear wheel.

When the clutch is disengaged (clutch lever pulled to left handlebar grip), the pressure plate is pulled outward (by clutch cable action) against the diaphragm spring, thereby compressing the diaphragm spring. With the pressure plate retracted, strong inward force no longer squeezes the clutch plates together. The fiber plates are now free to rotate at a different relative speed than that of the steel and spring plates (i.e. – Slippage between the clutch plates occurs). The result is that the rotational force of the clutch shell is no longer fully transmitted through the "unlocked" clutch plates to the clutch hub. The engine is free to rotate at a different speed than the rear wheel.

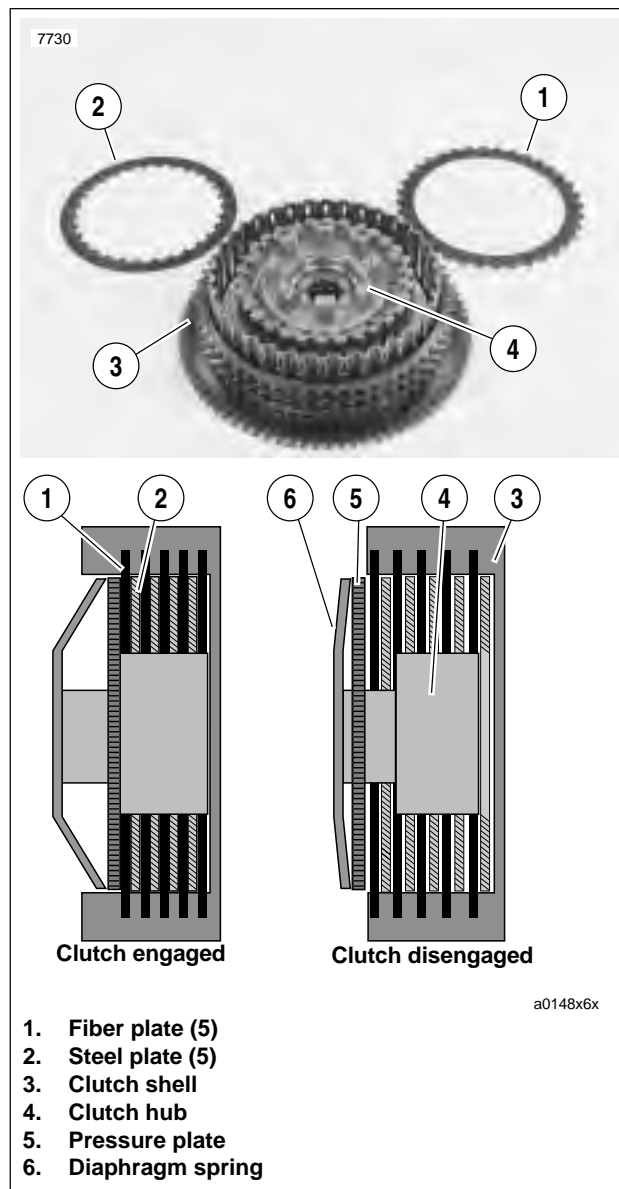


Figure 6-11. Clutch Plates and Hub/Shell Assembly

Table 6-5. Clutch Troubleshooting

SYMPTOM	CAUSE (CHECK IN FOLLOWING ORDER)	REMEDY
Clutch slips.	Incorrect clutch release adjustment. Worn clutch plates.	Check and adjust clutch release mechanism. Check service wear limits. Replace plates.
Clutch drags.	Incorrect clutch release adjustment. Worn clutch release ramps or balls. Warped clutch steel plates. Blade worn or damaged clutch gear splines. Overfilled primary.	Check and adjust clutch release mechanism. Replace release ramps and/or balls. Replace clutch steel plates. Replace clutch gear or hub as required. Drain lubricant to correct level.

REMOVAL/DISASSEMBLY

Clutch Pack

1. Remove seat. See [2.28 SEAT](#).

WARNING

To prevent accidental vehicle start-up, which could cause death or serious injury, disconnect negative (-) battery cable before proceeding. (00048a).

2. Disconnect negative battery cable.
3. Remove primary cover. See [6.2 PRIMARY CHAIN](#).

WARNING

Disassemble clutch using a spring compressing tool. The diaphragm spring is compressed and, if removed without proper tools can fly out, which could result in death or serious injury. (00292a)

4. See [Figure 6-12](#). Attach tools to compress clutch diaphragm spring (2).
 - a. Thread the CLUTCH SPRING FORCING SCREW (4) (Part No. HD-38515-91) onto the clutch adjusting screw.
 - b. Place the bridge (3) of SPRING COMPRESSING TOOL (Part No. HD-38515-A) against diaphragm spring.
 - c. Install bearing (5) and washer (6).
 - d. Thread the tool handle (1) onto end of forcing screw (4).

IMPORTANT NOTE

See [Figure 6-13](#). Turn compressing tool handle only the amount required to release spring seat and remove snap ring. Excessive compression of diaphragm spring could damage clutch pressure plate.

5. Remove pressure plate assembly.
 - a. Place a wrench on the clutch spring forcing screw flats to prevent the forcing screw (9) from turning.
 - b. Turn compressing tool handle (1) clockwise until tool relieves pressure on snap ring (6) and spring seat (8). Remove and discard snap ring (6).
 - c. Unseat spring seat (8) from the groove in clutch hub prongs.
 - d. Remove pressure plate assembly (7).
6. See [Figure 6-14](#). Remove the clutch pack from the hub/shell assembly. The pack consists of five fiber plates and five steel plates.

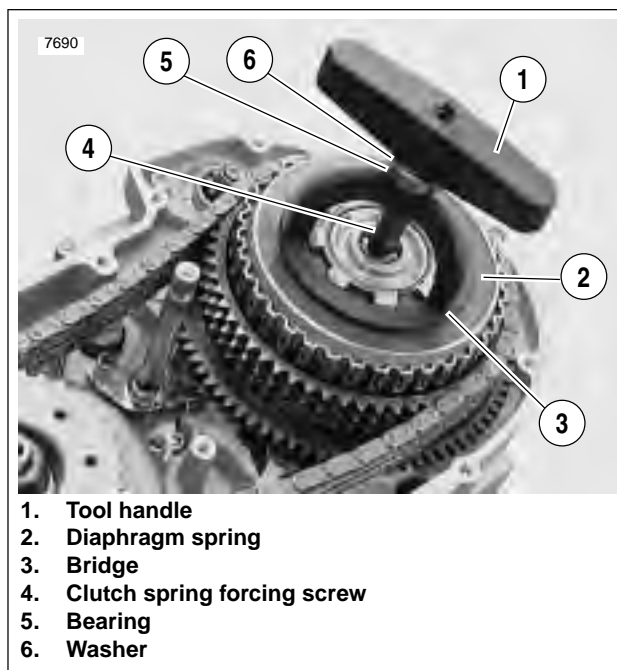
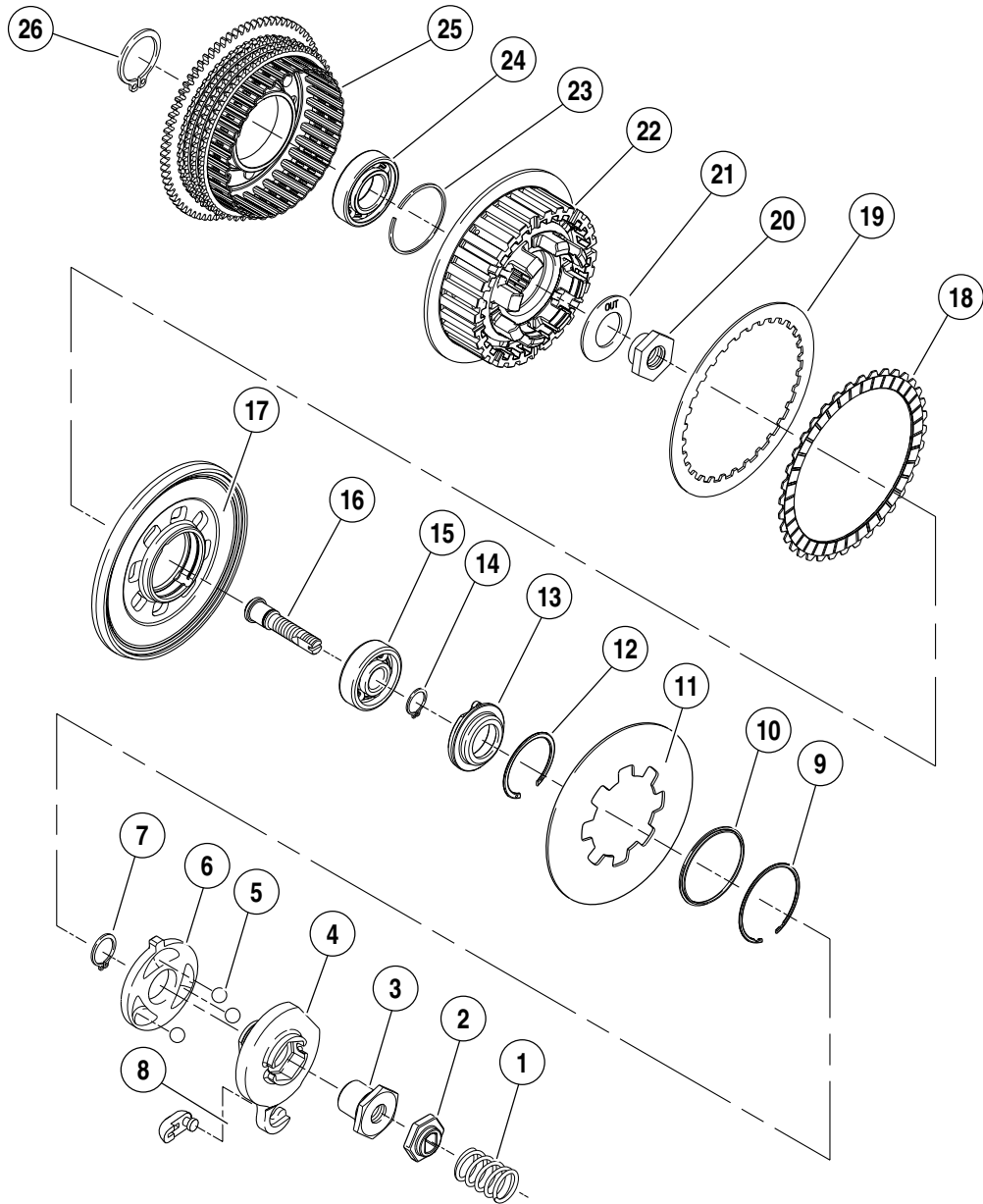


Figure 6-12. Compressing Clutch Diagram Spring



Figure 6-13. Pressure Plate Assembly

a0114x6x



- | | |
|----------------------|--------------------------------|
| 1. Spring | 14. Retaining ring |
| 2. Lockplate | 15. Bearing |
| 3. Nut | 16. Adjusting screw |
| 4. Outer ramp | 17. Pressure plate |
| 5. Ball (3) | 18. Friction plate (paper) (5) |
| 6. Inner ramp | 19. Steel plate (5) |
| 7. Retaining ring | 20. Mainshaft nut |
| 8. Coupling | 21. Washer, labeled "out" |
| 9. Retaining ring | 22. Clutch hub |
| 10. Spring seat | 23. Retaining ring |
| 11. Diaphragm spring | 24. Bearing |
| 12. Retaining ring | 25. Clutch shell and sprocket |
| 13. Release plate | 26. Retaining ring |

Figure 6-14. Clutch Assembly

Primary Chain/Drive

⚠ WARNING

To prevent accidental vehicle start-up, which could cause death or serious injury, disconnect negative (-) battery cable before proceeding. (00048a)

1. Remove negative battery cable from battery.
2. Remove primary cover. See 6.2 PRIMARY CHAIN.
3. Loosen engine sprocket.
 - a. Install SPROCKET LOCKING LINK (Part No. HD-38362).
 - b. Remove the engine sprocket nut.
 - c. Loosen, but do not remove, engine sprocket. If necessary, use the slotted portion of TWO CLAW PULLER (Part No. HD-97292-61) and two bolts to loosen the engine sprocket.

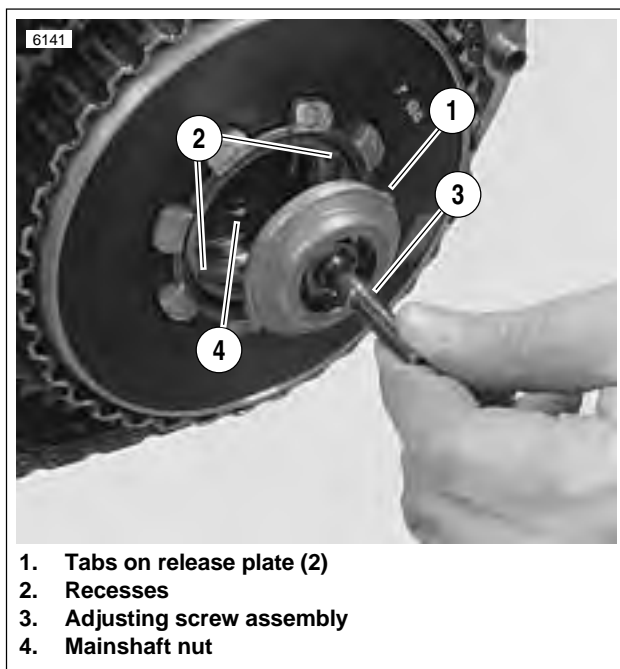


Figure 6-15. Aligning Tabs

4. See Figure 6-15. Remove adjusting screw assembly.
 - a. Remove large retaining ring.
 - b. Remove adjusting screw assembly from pressure plate.

IMPORTANT NOTE

See Figure 6-15. Mainshaft nut has left-hand threads. To prevent damage, turn nut clockwise to loosen and remove from mainshaft.

5. Remove mainshaft nut and washer.
6. Remove the clutch assembly, primary chain and engine sprocket as a unit.
 - a. Inspect primary chain and sprockets for damage or excessive wear.
 - b. Inspect stator and rotor. See 7.14 ALTERNATOR.
 - c. Replace damaged parts as necessary.
7. Install adjusting screw assembly into pressure plate.

- a. See Figure 6-15. Align two tabs on perimeter of release plate with corresponding recesses in pressure plate.
- b. See Figure 6-16. Secure the adjusting screw assembly with large retaining ring.
8. Attach tools to compress clutch diaphragm spring. See Step 2 of CLUTCH PACK under 6.4 PRIMARY DRIVE/CLUTCH.
9. Remove clutch pack components. See Steps 3-4 of CLUTCH PACK under 6.4 PRIMARY DRIVE/CLUTCH.
10. See Figure 6-13. Disassemble pressure plate.
 - a. Place a wrench on the clutch spring forcing screw flats to prevent the forcing screw from turning.
 - b. Turn the compressing tool handle counterclockwise until the handle spins off.
 - c. Remove washer, bearing and bridge.
 - d. Remove clutch spring forcing screw from clutch adjusting screw.
 - e. Remove spring seat and diaphragm spring from pressure plate.

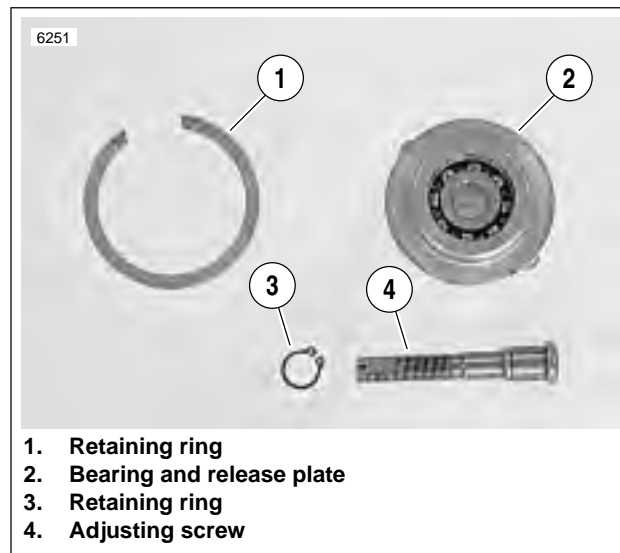


Figure 6-16. Adjusting Screw Assembly

11. See Figure 6-16. Remove and disassemble adjusting screw assembly.
 - a. Remove large retaining ring.
 - b. Remove adjusting screw assembly from pressure plate.
 - c. If necessary, disassemble adjusting screw assembly. Remove and discard small retaining ring and then separate the adjusting screw from the bearing and release plate. Remove bearing from release plate.

IMPORTANT NOTE

See [Figure 6-14](#). To prevent possible damage to the bearing, the clutch hub and shell assembly should not be disassembled unless the bearing, hub or shell require replacement. If the assembly is pressed apart, the bearing must be replaced.

12. Disassemble clutch hub and clutch shell if necessary.
 - a. Remove retaining ring from inboard end of clutch hub.
 - b. Using an arbor press, separate clutch hub from assembly of clutch shell, bearing and retaining ring.
 - c. Remove retaining ring from groove in clutch shell.
 - d. Press on the inboard side of bearing outer race to remove bearing from clutch shell.

INSPECTION**WARNING**

Compressed air can pierce the skin and flying debris from compressed air could cause serious eye injury. Wear safety glasses when working with compressed air. Never use your hand to check for air leaks or to determine air flow rates. (00061a)

1. Wash all parts, except fiber (friction) plates and bearing, in cleaning solvent. Blow dry with compressed air. Examine the clutch components as follows:
 - a. Check all clutch plates for wear and discoloration.
 - b. Inspect each steel (drive) plate for grooves.
 - c. Place each steel plate on a flat surface. Using a feeler gauge, check for flatness in several places. Replace any plates that are damaged or are warped more than 0.006 in. (0.152 mm).
2. Check the diaphragm spring for cracks or bent tabs. Install a **new** spring if either condition exists.
3. See [Figure 6-18](#). Check fiber plates for thickness.
 - a. Wipe the lubricant from the five fiber plates and stack them on top of each other.
 - b. Measure the thickness of the five stacked fiber plates with a dial caliper or micrometer. The minimum thickness must be 0.413 in. (10.490 mm).
 - c. If the thickness is less than specified, discard the fiber plates and steel plates. Install a **new** set of both friction and steel plates.
4. See [Figure 6-17](#). Check the clutch shell.
 - a. Inspect primary chain sprocket (1) and the starter ring gear (2) on the clutch shell. If either sprocket or ring gear are badly worn or damaged, replace the clutch shell.
 - b. Check the slots (3,4) that mate with the clutch plates on both clutch shell and hub. If slots are worn or damaged, replace shell and/or hub.
 - c. If clutch shell was removed from motorcycle, check the bearing for smoothness. Rotate the clutch shell while holding the clutch hub. If bearing is rough or binds, it must be replaced.

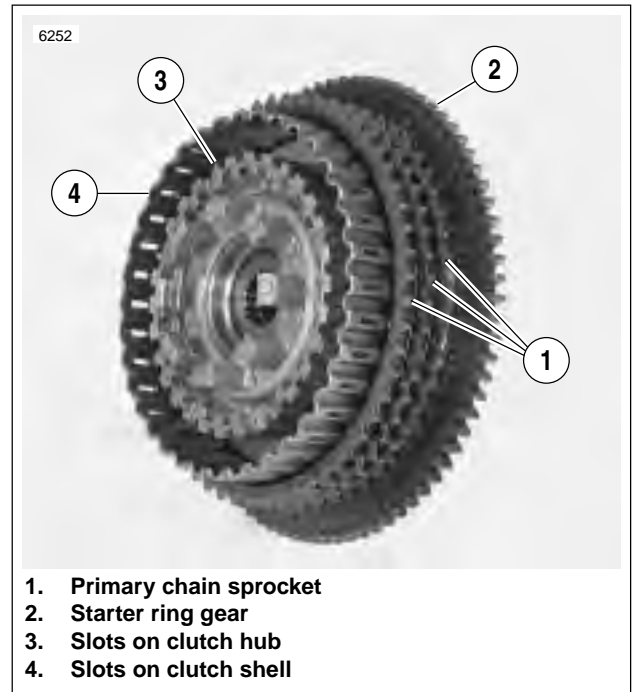


Figure 6-17. Checking Clutch Shell



Figure 6-18. Measuring Friction Plates

ASSEMBLY

Clutch Pack

- See [Figure 6-14](#). Install the clutch pack which consists of five fiber plates and five steel plates, into the clutch hub. The order of plate assembly, from inboard to outboard, is as follows:

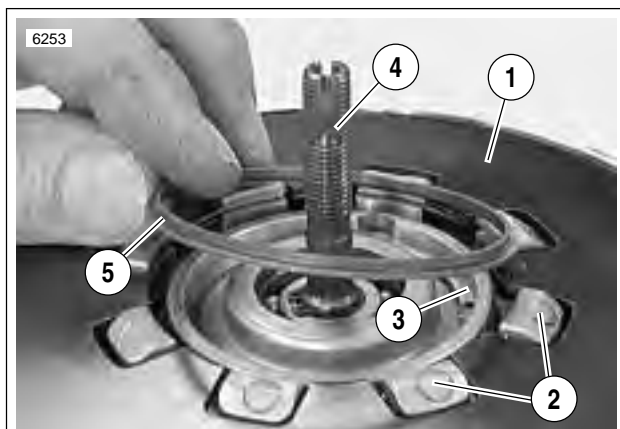
St - F - St - F - St - F - St - F - St - F

(St = Steel plate, F = Fiber plate)

IMPORTANT NOTE

See [Figure 6-13](#). Turn compressing tool handle only the amount required to install spring seat and snap ring. Excessive compression of diaphragm spring could damage clutch pressure plate.

- Place assembly of spring seat, **new** snap ring, diaphragm spring, pressure plate, adjusting screw components and compressing tool onto clutch hub and against clutch pack.
 - See [Figure 6-19](#). Align square openings of pressure plate and diaphragm spring so that the assembly can be installed over prongs of clutch hub.
 - Position spring seat with its larger O.D. side toward diaphragm spring.
 - See [Figure 6-20](#). Place a wrench on the clutch spring forcing screw flats to prevent the forcing screw from turning.
 - Turn compressing tool handle clockwise until diaphragm spring compresses just enough to install spring seat and **new** snap ring into the groove of clutch hub prongs.
 - With snap ring positioned against outboard side of spring seat, and fully seated in groove of clutch hub, carefully loosen and remove compression tool.



- Diaphragm spring (pressure plate below)
- Prongs on clutch hub
- Retaining ring
- Adjusting screw assembly
- Spring seat

Figure 6-19. Spring Seat Installation

Primary Drive

- See [Figure 6-20](#). Assemble clutch hub and shell if necessary.
 - Press **new** bearing in clutch shell. Secure bearing with a **new** retaining ring.
 - Press inboard end of clutch hub into shell bearing. Secure with **new** retaining ring on end of hub.
- Assemble pressure plate hardware.
 - See [Figure 6-16](#). Place bearing inside release plate. Insert adjusting screw through bearing and release plate. Secure with **new** retaining ring.
 - See [Figure 6-19](#). Position diaphragm spring with its concave side facing toward pressure plate onto pressure plate assembly.
 - Insert adjusting screw assembly into pressure plate. Secure with large retaining ring.
 - Position spring seat with its larger O.D. side toward diaphragm spring.
- Attach tools to compress clutch diaphragm spring. Do not tighten compressing tool against diaphragm spring at this time. See Step 2 of [CLUTCH PACK](#) under [6.4 PRIMARY DRIVE/CLUTCH](#).
- Install the clutch pack. Follow all instructions of [CLUTCH PACK](#) under [6.4 PRIMARY DRIVE/CLUTCH](#).

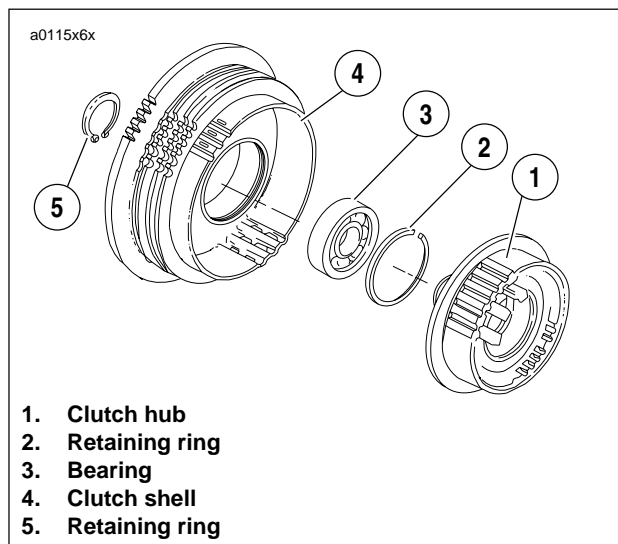


Figure 6-20. Clutch Hub and Shell Assembly

INSTALLATION

NOTE

If clutch pack replacement was the only service work performed, start with Step 5.

1. Install the engine sprocket, clutch assembly and primary chain as a unit into primary chaincase.
2. See Figure 6-21. Install the engine sprocket nut.
 - a. Place SPROCKET LOCKING LINK (Part No. HD-38362) between primary chain and engine sprocket.
 - b. Apply two or three drops of Loctite Threadlocker 271 (red) onto threads of sprocket shaft.
 - c. Install engine sprocket nut. Tighten to 190-210 ft-lbs (258-285 Nm).

IMPORTANT NOTE

See Figure 6-22. Washer must be installed with the word "out" facing the mainshaft nut or transmission may be damaged.

3. See Figure 6-22. Install mainshaft nut and washer.
 - a. Apply two or three drops of Loctite Threadlocker 271 (red) onto threads on end of mainshaft.
 - b. Place washer on mainshaft with the word "out" facing away from clutch hub.
 - c. Install nut (**left-hand threads**). Tighten to 70-80 ft-lbs (95-109 Nm).
4. Remove SPROCKET LOCKING LINK.
5. Install adjusting screw assembly into pressure plate.
 - a. See Figure 6-15. Align two tabs on perimeter of release plate with corresponding recesses in pressure plate.
 - b. See Figure 6-16. Secure the adjusting screw assembly with retaining ring.
6. Install primary cover. See 6.2 PRIMARY CHAIN.
7. Install left footpeg support bracket. See 2.21 FOOTPEGS AND FOOTPEG SUPPORT BRACKETS.

⚠ WARNING

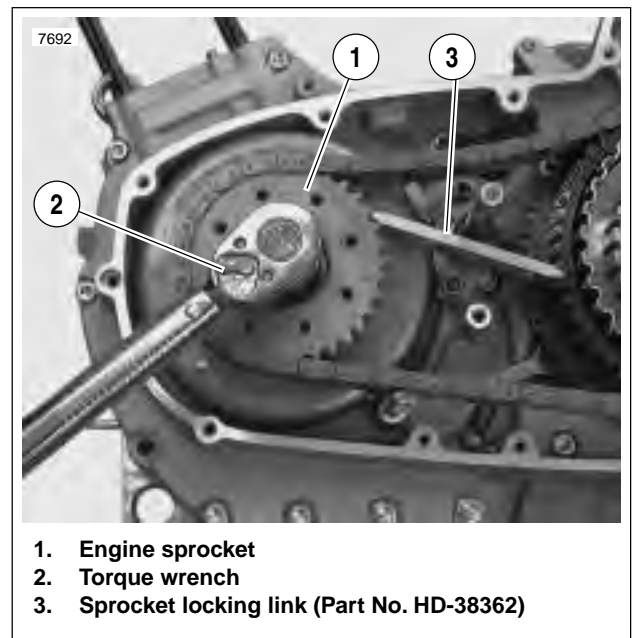
Connect positive (+) battery cable first. If positive (+) cable should contact ground with negative (-) cable connected, the resulting sparks can cause a battery explosion, which could result in death or serious injury. (00068a)

8. Connect negative battery cable to battery terminal. Tighten fastener to 72-96 in-lbs (8-11 Nm).

⚠ WARNING

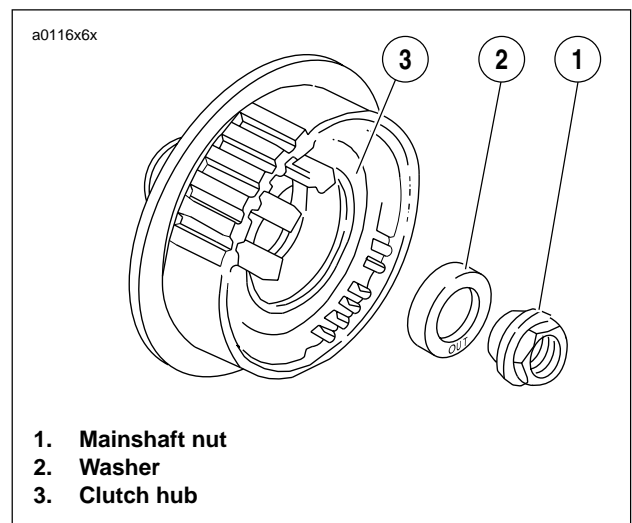
After installing seat, pull upward on front of seat to be sure it is in locked position. While riding, a loose seat can shift causing loss of control, which could result in death or serious injury. (00070a)

9. Install seat. See 2.28 SEAT.



1. Engine sprocket
2. Torque wrench
3. Sprocket locking link (Part No. HD-38362)

Figure 6-21. Sprocket Locking Link



1. Mainshaft nut
2. Washer
3. Clutch hub

Figure 6-22. Mainshaft Nut and Washer

NOTES

GENERAL

See Figure 6-23. The transmission is a five-speed constant-mesh type housed in an extension of the crankcase.

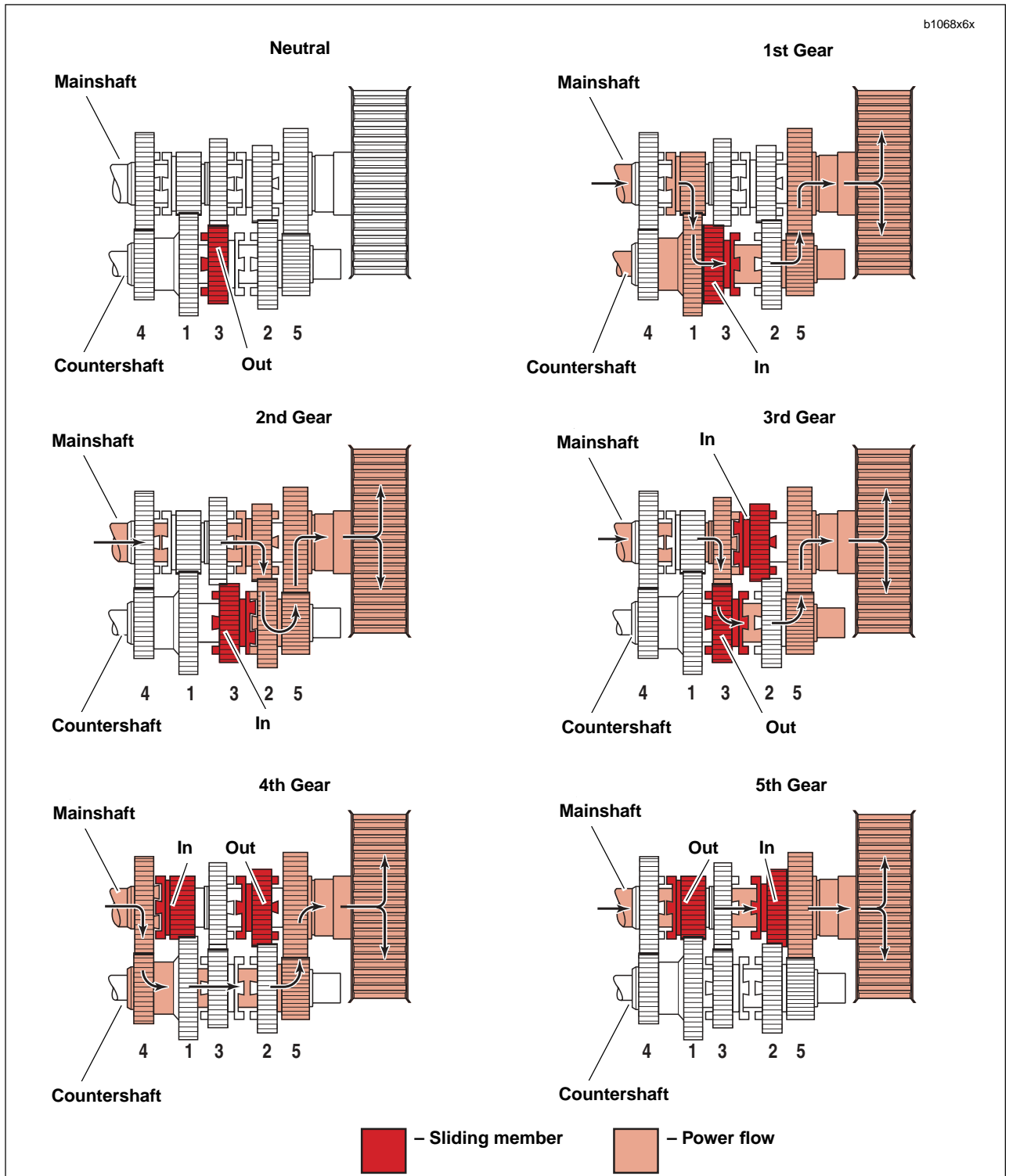


Figure 6-23. Transmission Power Flow

GENERAL

The rear compartment of the left and right crankcase halves form the transmission case. Servicing of transmission components requires removing the engine and disassembling (splitting) the crankcase.

REMOVAL

1. Remove transmission sprocket. See [6.14 TRANSMISSION SPROCKET](#).
2. Remove engine from chassis. See [3.3 STRIPPING MOTORCYCLE FOR ENGINE SERVICE](#).
3. Support engine using ENGINE SUPPORT STAND (Part No. HD-42310/HD-43646 or HD-43682).
4. Disassemble top end. See [3.5 CYLINDER HEAD](#).
5. Disassemble gearcase. See [3.15 GEARCASE COVER AND CAM GEARS](#).
6. Remove primary cover. See [6.2 PRIMARY CHAIN](#).
7. Remove clutch assembly, primary chain and engine sprocket. See [6.4 PRIMARY DRIVE/CLUTCH](#).

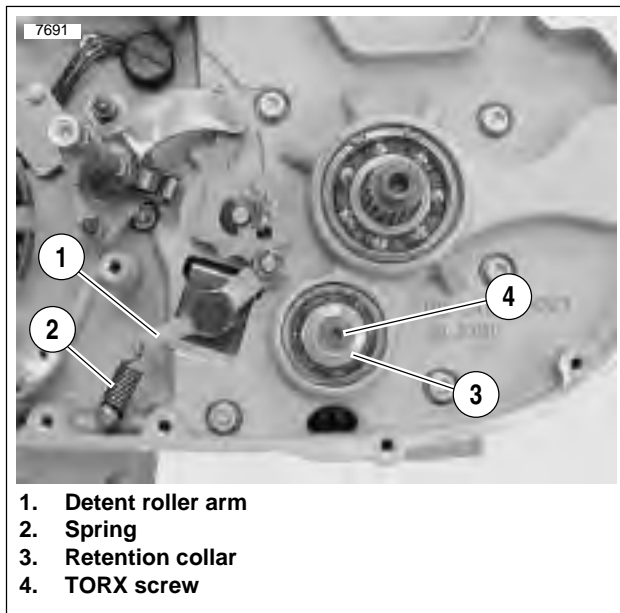


Figure 6-24. Countershaft Retainer

8. See [Figure 6-24](#). Place transmission in gear. Remove countershaft TORX screw (4) and retention collar (3).

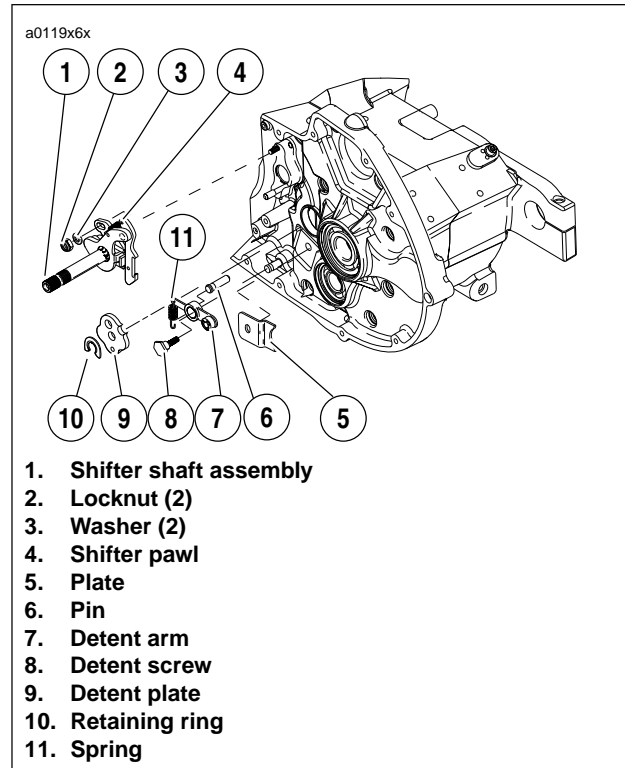


Figure 6-25. Shifter Shaft Assembly

9. See [Figure 6-25](#). Detach spring (11) from groove in post.
10. Remove retaining ring (10) and detent plate (9). Discard retaining ring (10). You will need to use a **new** retaining ring for installation.
11. Remove starter. See [5.7 STARTER](#).
12. See [Figure 6-25](#). Remove two locknuts (2) and washers (3) which attach shifter shaft assembly (1) to studs at transmission case. Remove shifter shaft assembly (1).
13. Remove detent screw (8), detent arm (7) and spring (11).

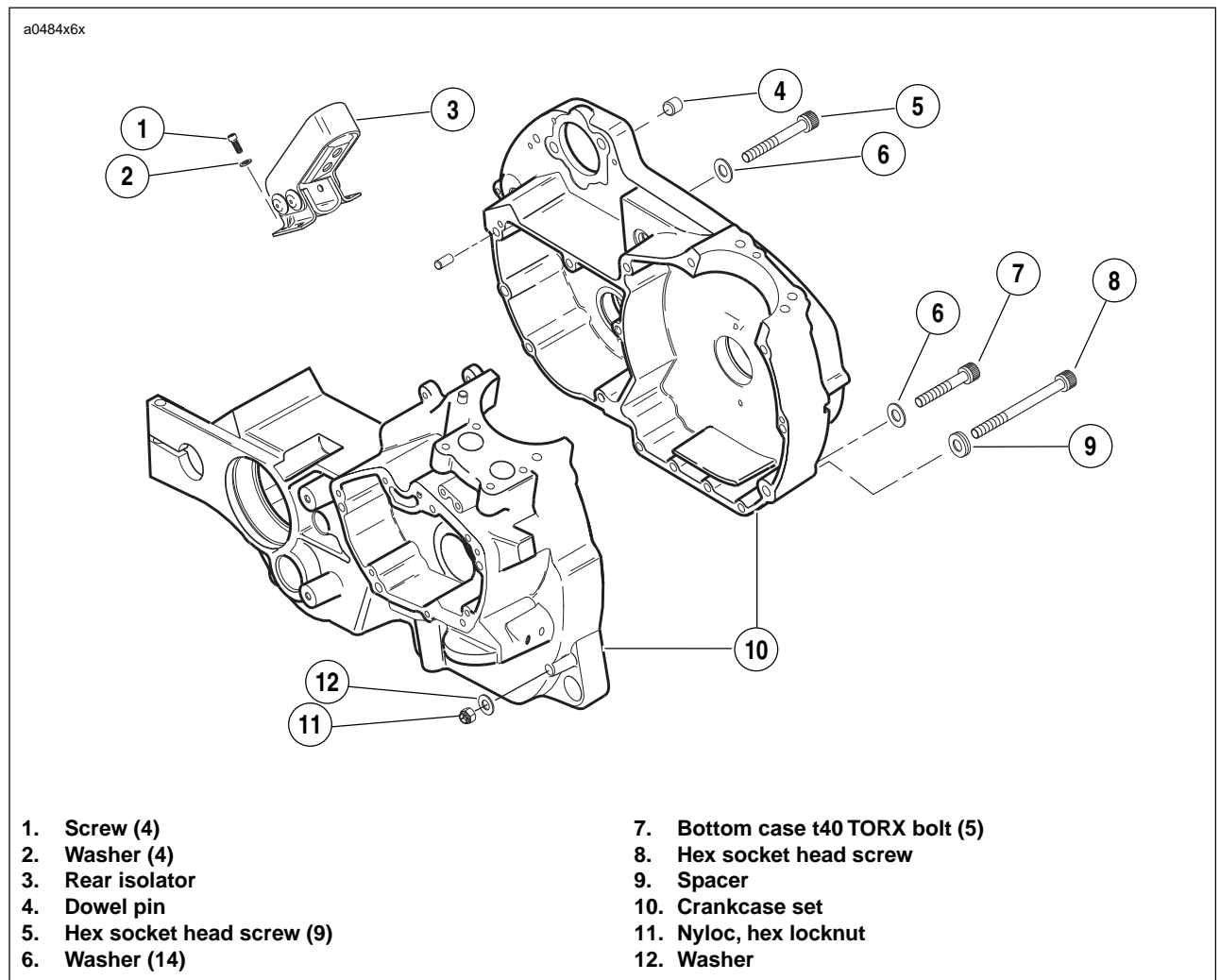


Figure 6-26. Crankcase Hardware



Figure 6-27. Splitting Crankcase Halves

14. See [Figure 6-26](#). Remove all transmission case bolts.
15. Remove rear isolator (3) and mounting hardware (1, 2).
16. See [Figure 6-27](#). Separate crankcase halves.

CASE REMOVAL

NOTES

- If transmission only is being serviced, do not remove flywheel assembly.
- For crankcase, flywheel or other major servicing, the flywheel assembly can be removed at any time. The same specialty tools are used.

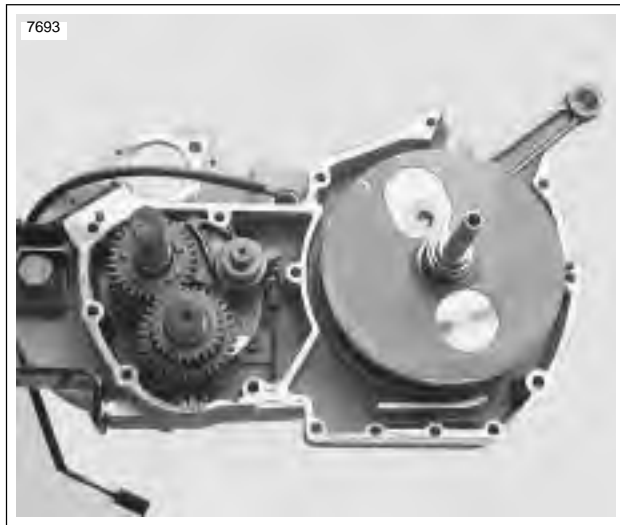
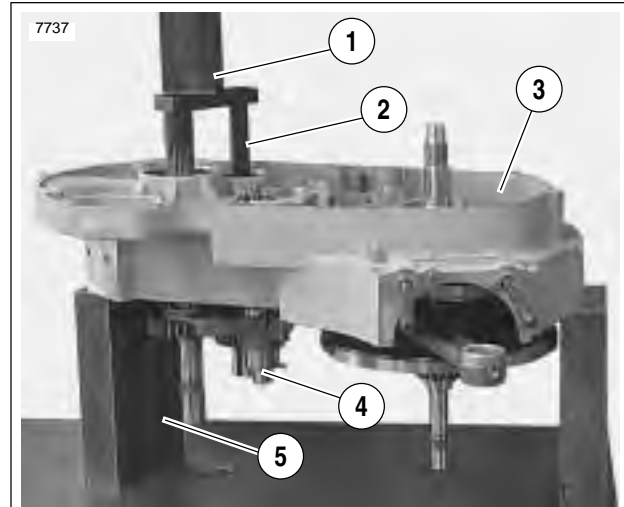


Figure 6-28. Transmission Assembly

1. See [Figure 6-28](#). Remove transmission case. See [6.6 TRANSMISSION CASE](#)
2. Remove crankcase and transmission assembly from engine stand.



1. Arbor press
2. Transmission remover (Part no. B-43985-1)
3. Crankcase
4. Transmission assembly
5. Parallel supports

Figure 6-29. Transmission Remover/Installer on Fixture

3. See [Figure 6-29](#). Place crankcase half (3) and transmission assembly (4) on arbor press (1) and support transmission assembly on parallel supports (5).
4. Press transmission assembly using TRANSMISSION REMOVER (2) (Part No. B-43985-1) to remove transmission assembly from crankcase half.
5. Remove crankcase from fixture.

SHIFTER FORKS AND DRUM DISASSEMBLY

1. See [Figure 6-30](#). Remove and discard the three fork cotter pins (14).

2. Remove three shifter fork pins (15). A small magnet is useful in freeing the fork pins.
3. Slide shifter fork drum (19) away through shifter forks. The neutral indicator pin (20) prevents removal in the other direction.
4. Remove shifter forks (16, 17, 18).

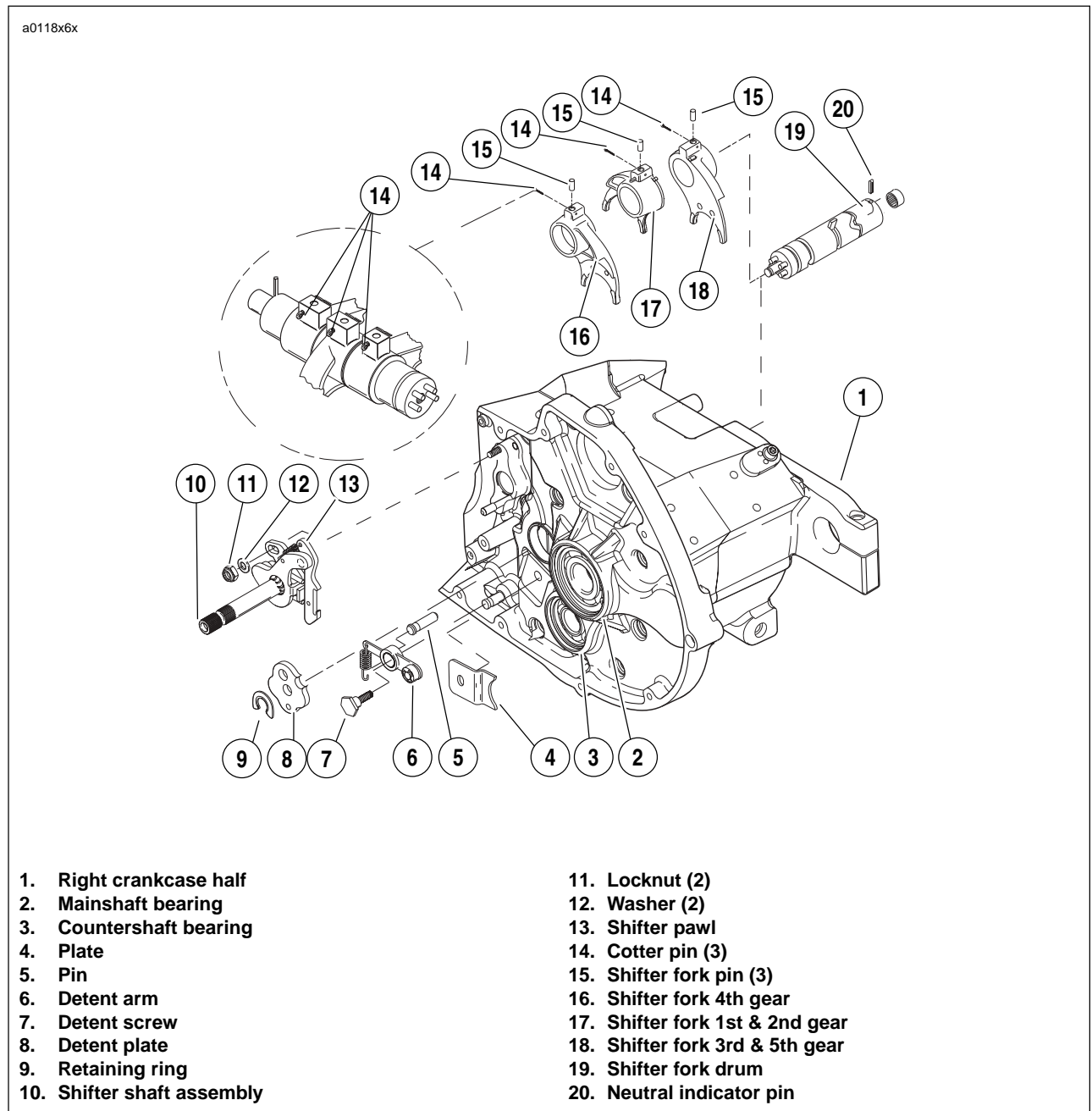


Figure 6-30. Shifter Mechanism

DISASSEMBLY

NOTE

As the transmission runs, each part develops a certain wear pattern and a kind of "set" with its mating parts. For this reason, it is important that each component be reinstalled in its original location and facing its original direction.

1. See Figure 6-31. As each component is removed, place it on a clean surface in the exact order of removal.

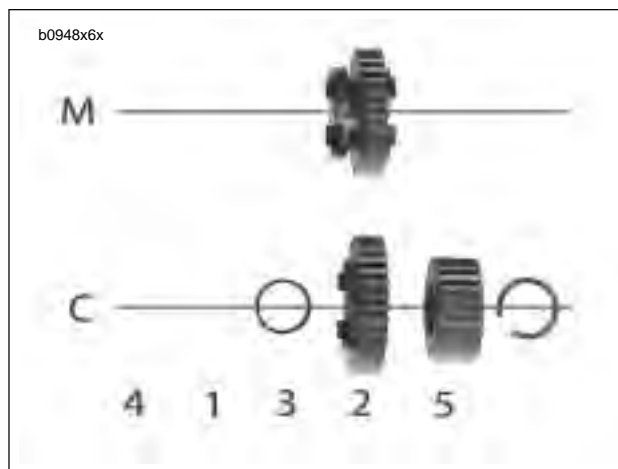
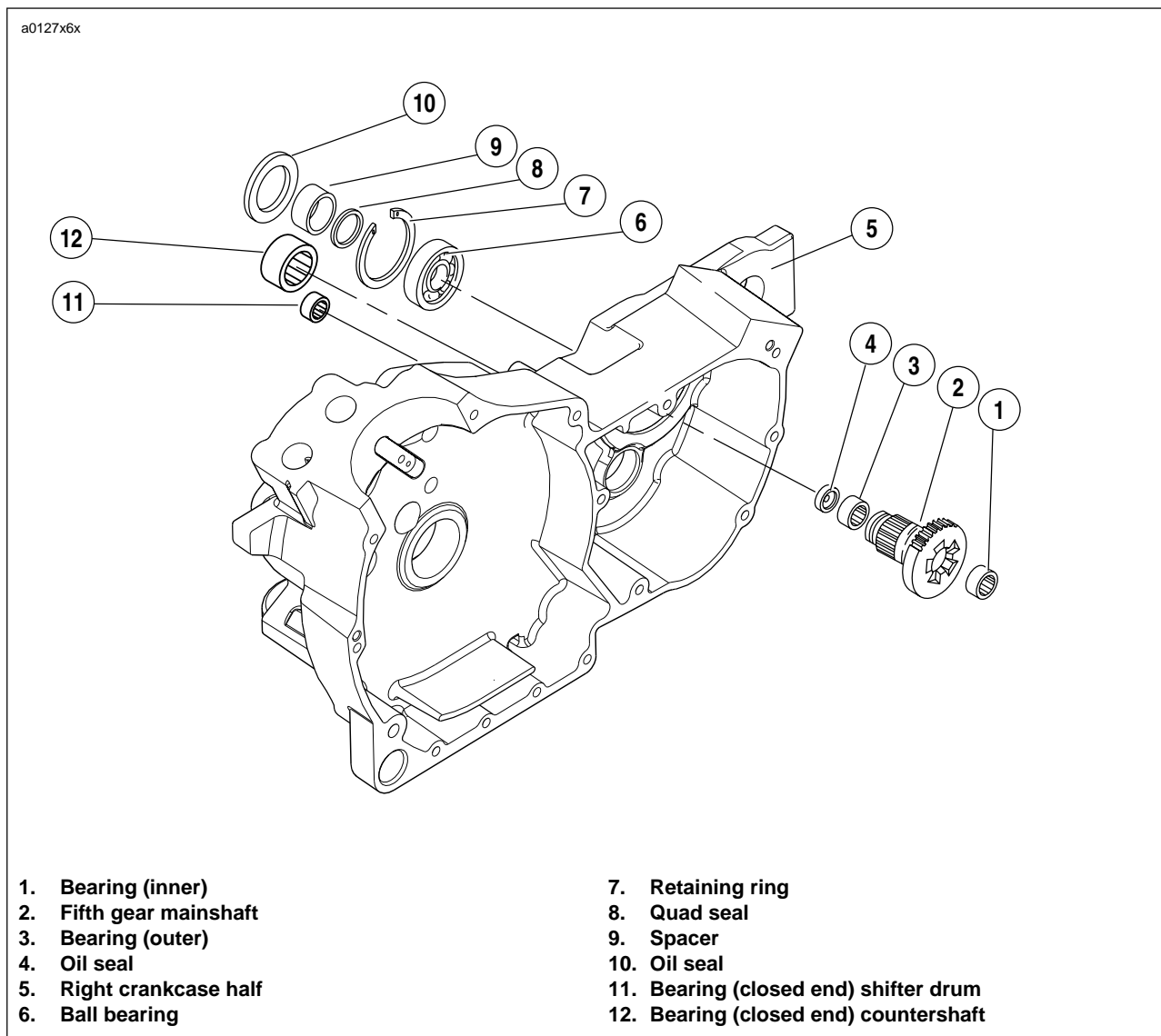


Figure 6-31. Recording The Order of Disassembly



- | | |
|-------------------------|---------------------------------------|
| 1. Bearing (inner) | 7. Retaining ring |
| 2. Fifth gear mainshaft | 8. Quad seal |
| 3. Bearing (outer) | 9. Spacer |
| 4. Oil seal | 10. Oil seal |
| 5. Right crankcase half | 11. Bearing (closed end) shifter drum |
| 6. Ball bearing | 12. Bearing (closed end) countershaft |

Figure 6-32. Transmission Assembly Right Crankcase Half

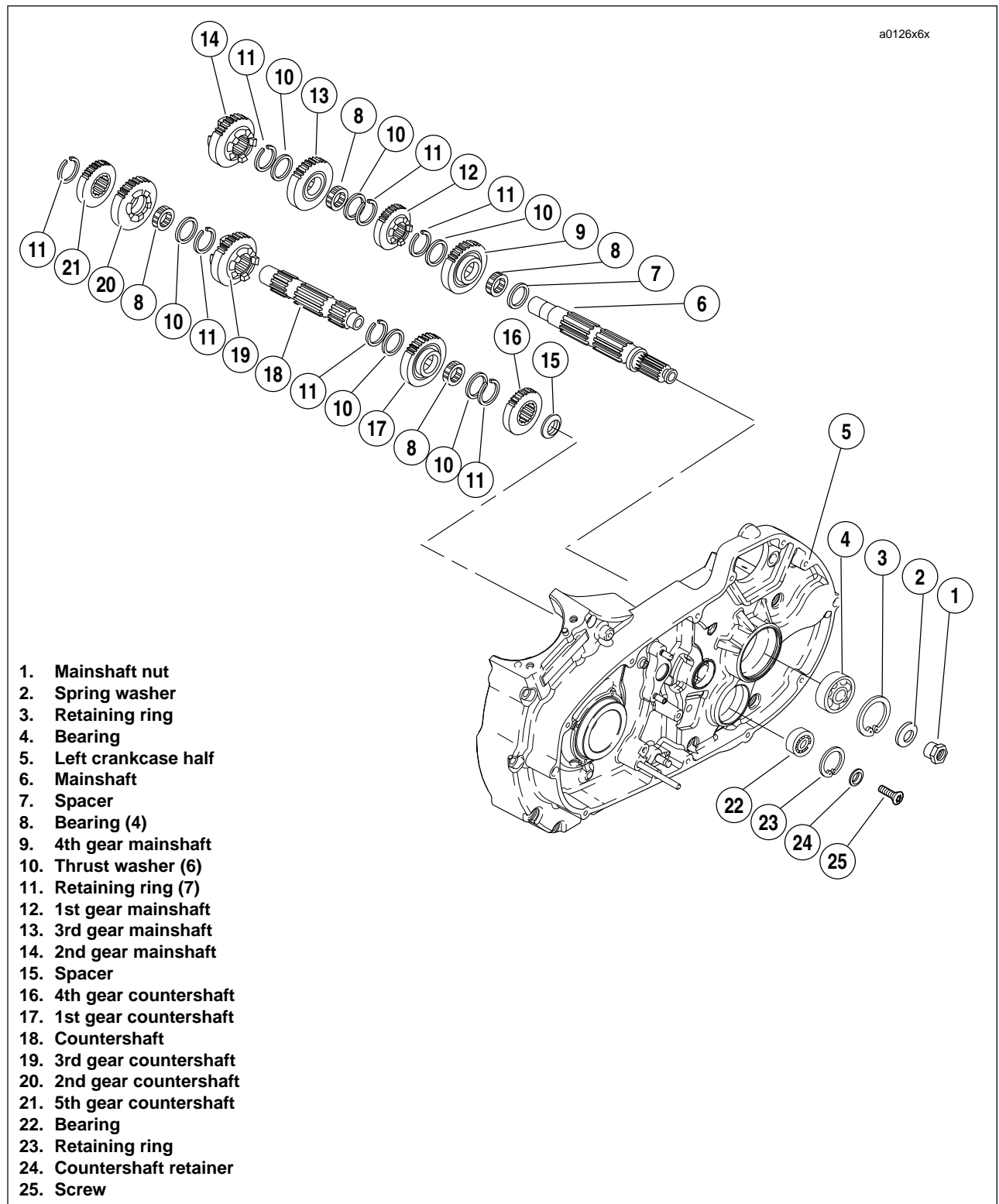


Figure 6-33. Transmission Assembly Left Crankcase Half

MAINSHAFT DISASSEMBLY

1. See [Figure 6-33](#). Remove mainshaft 2nd (14) gear from mainshaft (6).
2. At mainshaft, between mainshaft 1st gear (12) and mainshaft 3rd gear (13), expand retaining ring (11) and move next to mainshaft 1st gear (12) along with thrust washer (10). Move mainshaft 3rd gear (13) as far as possible toward mainshaft 1st gear (12). Expand retaining ring (11) at opposite side of mainshaft 3rd gear (13) and slide off end of shaft. Slide thrust washer (10) off end of mainshaft.
3. Remove mainshaft 3rd gear (13) and its split bearing (8).
4. Slide thrust washer (10) off end of mainshaft. Expand retaining ring (11), which is next to mainshaft 1st gear (12), and slide off end of shaft.
5. Remove mainshaft 1st gear (12) off mainshaft.
6. Expand retaining ring (11) and slide off end of shaft. Slide thrust washer (10) off end of mainshaft.
7. Remove mainshaft 4th gear (9).
8. Remove split bearing (8) and spacer (7).

COUNTERSHAFT DISASSEMBLY

1. See [Figure 6-33](#). Using RETAINING RING PLIERS (Part No. J-5586) remove and discard retaining ring (11) next to countershaft 5th gear (21). Slide countershaft 5th (21), and countershaft 2nd (20) off end of countershaft (18).
2. Remove split bearing (8) that was under countershaft 2nd gear (20) and thrust washer (10), including retaining ring (11) on the countershaft (6). Slide countershaft 3rd (19) gear off free end of shaft (18).
3. Remove beveled washer (spacer) (15) and countershaft 4th gear (16).
4. Expand retaining ring (11) located next to countershaft 1st gear (17). Remove retaining ring (11) and thrust washer (10). Slide countershaft 1st gear (17) off end of shaft. Remove split bearing (8).
5. Remove thrust washer (10). Expand remaining retaining ring (11) and slide off countershaft (18).

CLEANING AND INSPECTION

WARNING

Never use compressed air to “spin-dry” bearings. Spinning bearings with compressed air can also cause a bearing to fly apart, which could result in death or serious injury.

WARNING

Compressed air can pierce the skin and flying debris from compressed air could cause serious eye injury. Wear safety glasses when working with compressed air. Never use your hand to check for air leaks or to determine air flow rates. (00061a)

1. Clean all parts (except bearings) in cleaning solvent and blow dry with compressed air.
2. Check gear teeth for damage. If gears are pitted, scored, rounded, cracked or chipped, they should be replaced.
3. Inspect the engaging dogs on the gears. Replace the gears if dogs are rounded, cracked, battered, chipped or dimpled.
4. Discard all retaining rings that were removed.

MAINSHAFT SUB-ASSEMBLY

NOTE

During assembly, the split bearings (8) and the internal bores of the gears must be lubricated with FORMULA+ Primary/Transmission Lubricant prior to assembly. Leaving these parts dry could accelerate wear at start-up.

1. See [Figure 6-34](#). Install **new** retaining ring (11) and thrust washer (10) onto mainshaft (6) in the first ring groove from the end.
2. Install split bearing (8) onto mainshaft.
3. Locate mainshaft 4th gear (9), which can be identified by the two radial grooves at one side. Slide gear (9) onto shaft. Position gear over bearing (8) next to spacer (7).
4. Place spacer (7) over mainshaft and position next to split bearing (8).
5. Slide mainshaft 1st gear (12) onto mainshaft with the fork groove facing 4th gear (9).
6. Install thrust washer (10) and **new** retaining ring (11) next to mainshaft 1st gear (12).

NOTE

It will be necessary to push the retaining ring into final position (ring groove) with a screwdriver.

7. Install split bearing (8) onto mainshaft.
8. Install mainshaft 3rd gear (13) onto shaft over bearing (8).
9. Install thrust washer (10) and **new** retaining ring (11).
10. Install mainshaft 2nd gear (14) onto shaft with the fork groove facing 3rd gear (13).

COUNTERSHAFT SUB-ASSEMBLY

1. See [Figure 6-34](#). Install **new** retaining ring (11) and thrust washer (10) onto countershaft (18) in the second ring groove from the end.
2. Install split bearing (8) onto countershaft.
3. Locate countershaft 1st gear (17), which can be identified by the two radial grooves at one side. Slide gear (17) onto shaft. Position gear over bearing (8).
4. Install thrust washer (10) and **new** retaining ring (11) next to gear (17).
5. Locate countershaft 4th gear (16). This flat, shoulderless gear is splined and has a single radial groove at one side. Position gear next to retaining ring (11) on countershaft. Place beveled washer (spacer) (15) over end of shaft with beveled side away from countershaft 4th gear (16).
6. Install countershaft 3rd gear (19) on countershaft with fork groove facing away from countershaft 1st gear (17).
7. Install **new** retaining ring (11) on countershaft. Position **new** retaining ring in the second ring groove from the end. Install thrust washer (10) next to retaining ring (11). Install split bearing (8) in seat next to washer (10).
5. Install countershaft 2nd gear (20) with the locking dogs facing countershaft 3rd gear (19).
6. Install countershaft 5th gear (21) on countershaft.
7. Install **new** retaining ring (11) on countershaft.
8. Install shifter forks and drum. See [6.8 TRANSMISSION ASSEMBLY](#).

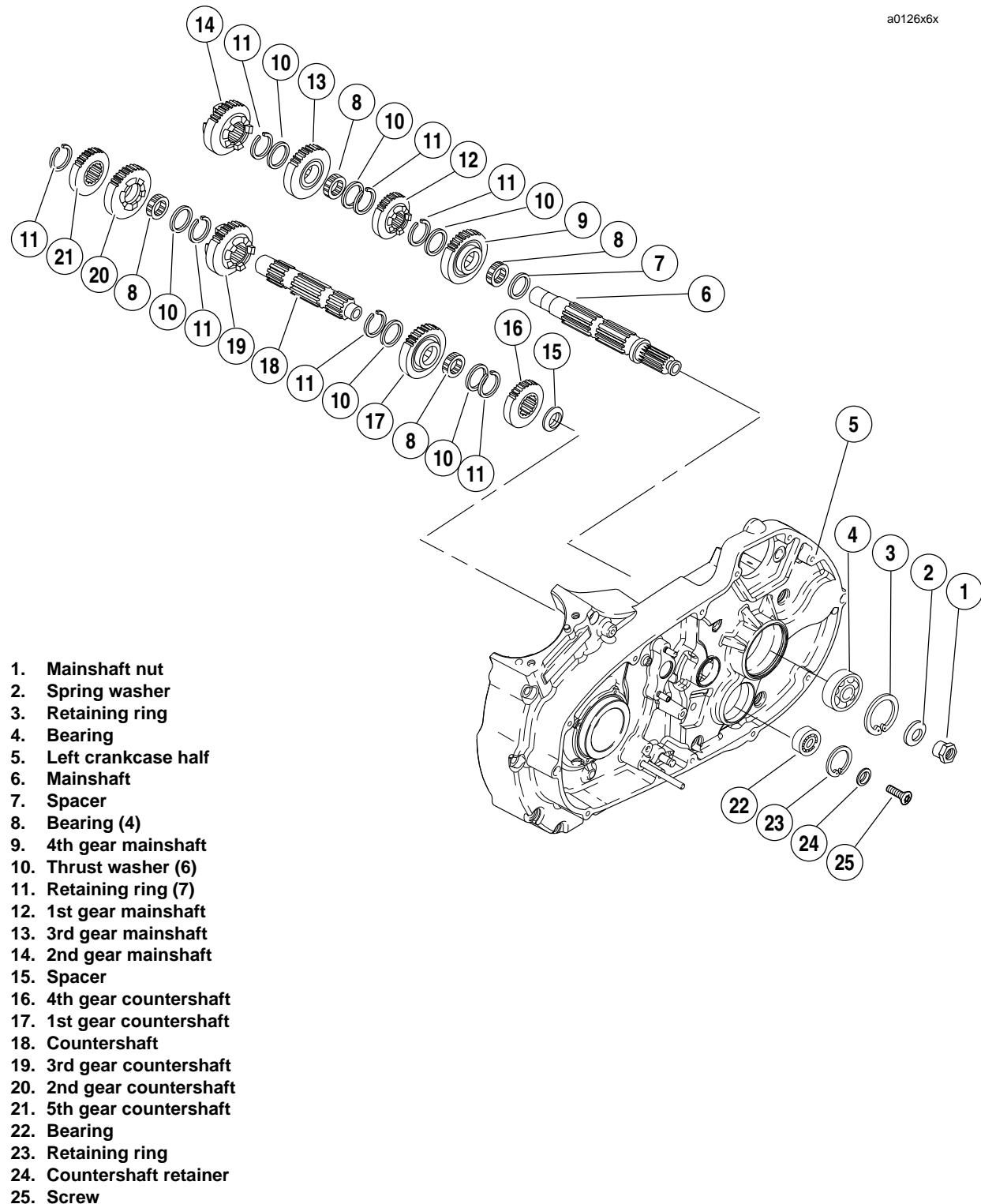


Figure 6-34. Transmission Assembly Left Crankcase Half

SHIFTER FORKS AND DRUM ASSEMBLY

1. See [Figure 6-35](#). for shifter fork identification.
2. Lubricate the shaft bore in fork with FORMULA+ Primary/Transmission Lubricant. Place 3rd and 5th gear shifter fork on shifter fork drum.
3. Lubricate the shaft bore in fork with FORMULA+ Primary/Transmission Lubricant. Place 1st and 2nd gear shifter fork on shifter fork drum.
4. Lubricate the shaft bore in fork with FORMULA+ Primary/Transmission Lubricant. Place 4th gear shifter fork on shifter fork drum.
5. See [Figure 6-36](#). Position the shifter drum shaft so that the neutral indicator switch activator pin is upward. The shaft is then in the neutral position.

IMPORTANT NOTE

To prevent possible cotter pin damage, the pins must be inserted through the shifter forks as shown in the inset of [Figure 6-36](#).

6. Align the hole through the top of each shifter fork with the appropriate cam groove in the shifter drum. Lubricate pins with FORMULA+ Primary/Transmission Lubricant. Drop pins through the holes in shifter forks. With a small screwdriver press on the pins while manipulating the forks back and forth until the pin seats in the drum groove. Secure pins in place with **new** cotter pins.
7. Align shifter fork assembly with transmission gear fork grooves.

NOTE

This completes transmission assembly. Transmission components are now prepared for installation into the left crankcase half.

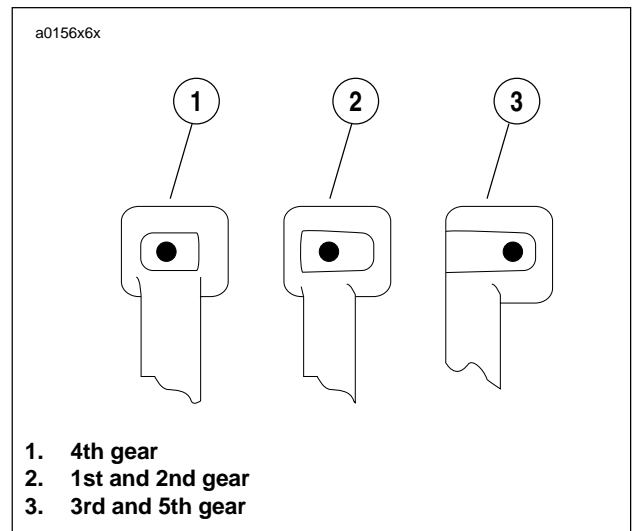


Figure 6-35. Shifter Fork Identification

NOTE

See Figure 6-36. Insert cotter pins as shown.

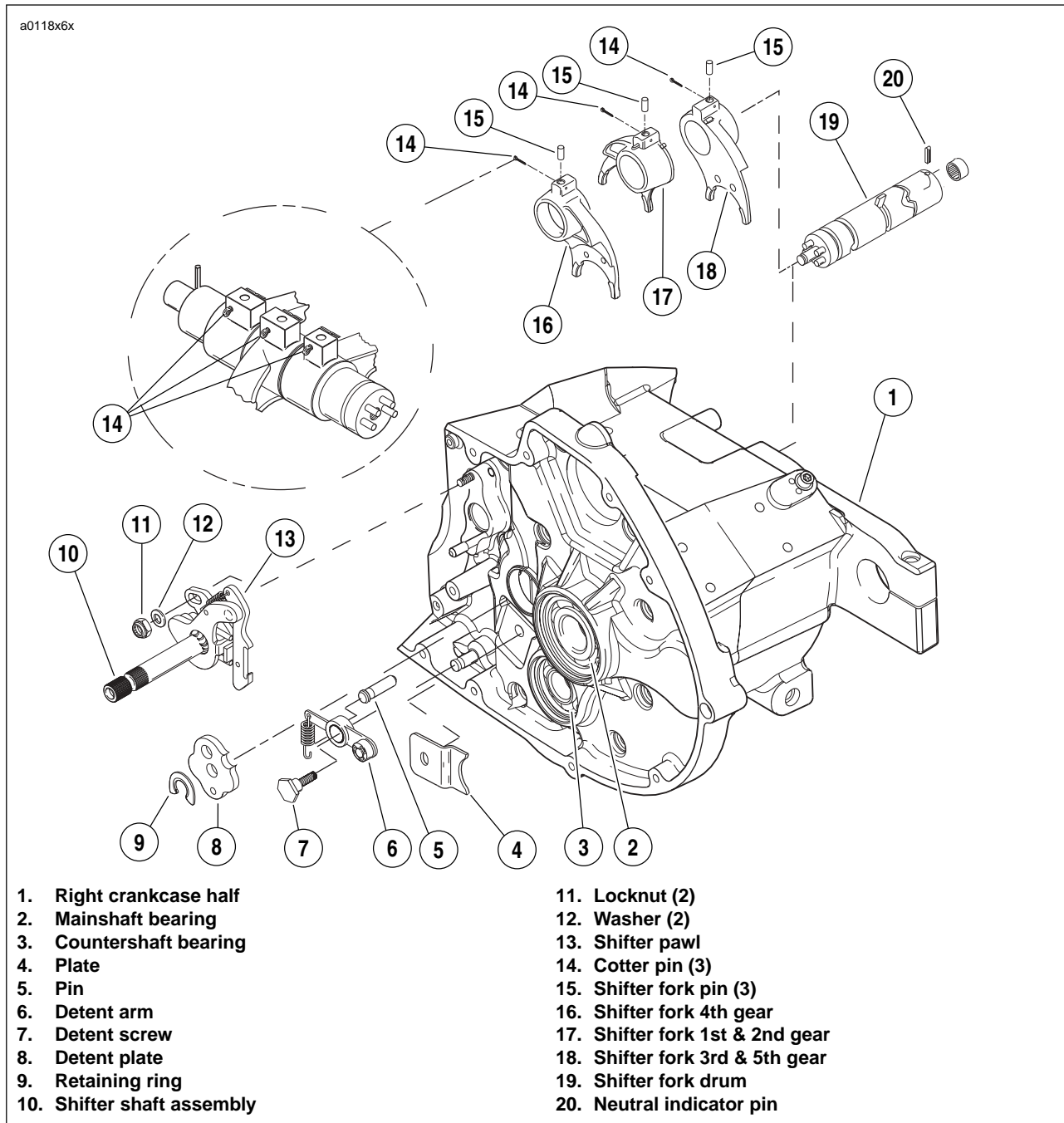


Figure 6-36. Shifter Mechanism

REMOVAL

1. Split crankcases in half. See 6.6 TRANSMISSION CASE.
2. Remove transmission as an assembly. See 6.6 TRANSMISSION CASE.

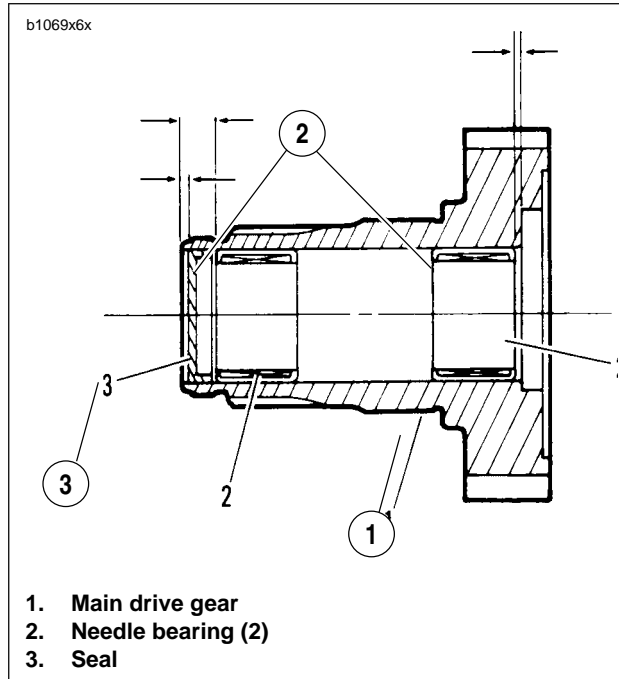


Figure 6-37. Main Drive Gear Assembly

3. See Figure 6-37. From inside case tap out seal at end of mainshaft 5th gear. Discard seal.

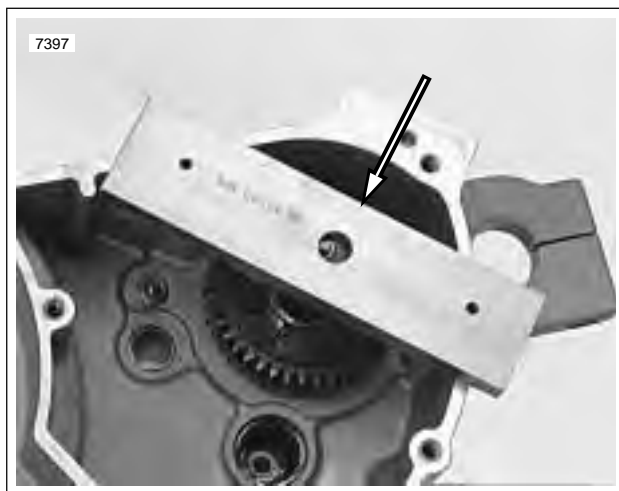


Figure 6-38. Mounting Cross Plate (Part No. B-43983)

4. See Figure 6-38. Place cross plate on crankcase as shown.

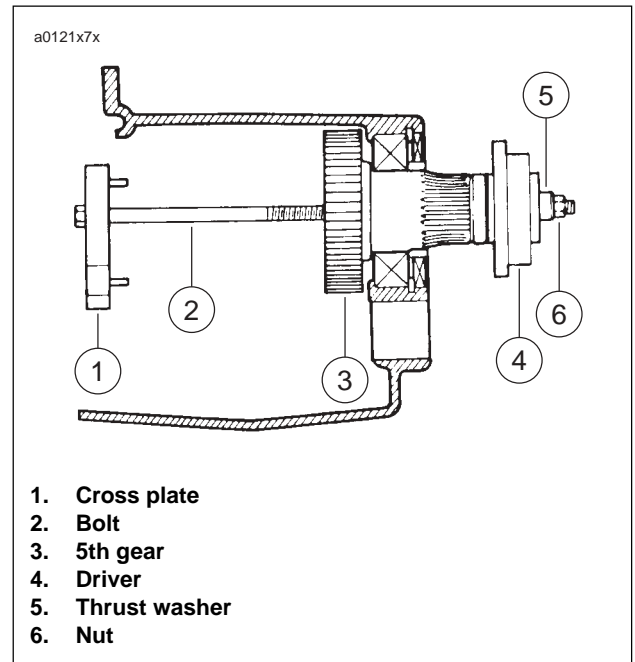


Figure 6-39. Removing Main Drive Gear

5. See Figure 6-39. Assemble MAIN DRIVE GEAR REMOVER AND INSTALLER (Part No. HD-35316A) with CROSS PLATE (Part No. B-45847).
6. Insert bolt (2) through cross plate (1) and 5th gear (3).

NOTE

When removing the main drive gear, the gear is pressed out against the resistance of the bearing inner race. Without any support at the inner race, the bearing is destroyed. Whenever the main drive gear is removed the main drive gear bearing will also have to be replaced.

9. At outside of case, place driver (4) and thrust washer (5) over end of bolt (2). Install and tighten nut (6) until 5th gear (3) is free.

DISASSEMBLY

Drive out needle bearings from inside bore of main drive gear. Do not reuse bearings after removal.

ASSEMBLY

1. See [Figure 6-40](#). Use INNER/OUTER MAIN DRIVE GEAR NEEDLE BEARING INSTALLATION TOOL (Part No. HD-37842-A) for assembly. Select which end of tool to use.
 - a. The end stamped 0.080 in. (2.032 mm) is for driving the bearing into the inner end.
 - b. The end stamped 0.315 in. (8.001 mm) is for the outer end bearing.
2. Assemble parts. The installation tool will automatically bottom on the gear when the correct depth is reached.
 - a. Place main drive gear on a press.
 - b. Press in the outer bearing to a depth of 0.315-0.285 in. (8.001-7.239 mm).
 - c. Press in the inner bearing to a depth of 0.080 in. (2.032 mm).

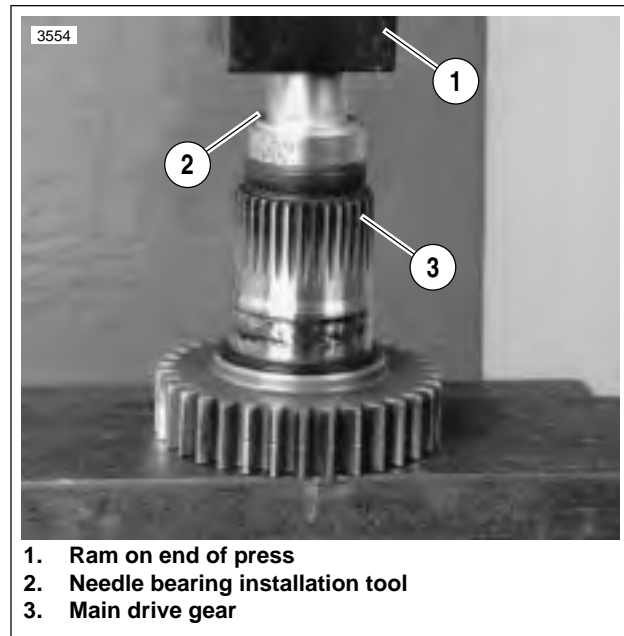


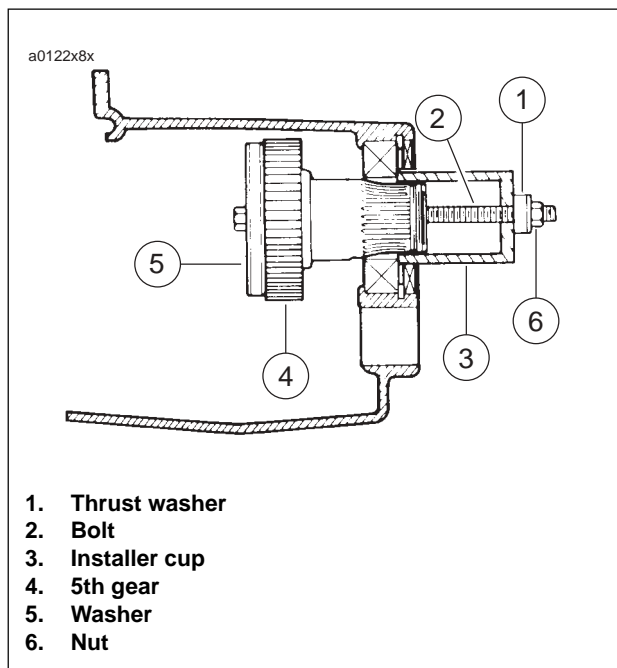
Figure 6-40. Needle Bearing Installation Tool

INSTALLATION

1. Replace main drive gear bearing.
2. See [Figure 6-41](#). Lubricate both main drive gear needle bearing assemblies and the mating surface of the mainshaft with HARLEY-DAVIDSON SPECIAL PURPOSE GREASE (Part No. 99857-97).
3. See [Figure 6-42](#). Use MAIN DRIVE GEAR REMOVER AND INSTALLER (Part No. HD-35316-A) for assembly.
 - a. Take bolt (2) and place washer (5) followed by main drive gear (4) over end of bolt.
 - b. From inside of case insert bolt and main drive gear through inner race of ball bearing.
 - c. Insert threaded end of bolt (2) through installer cup (3) and thrust washer (1).
 - d. Thread nut (6) onto end of bolt (2). Tighten nut (6) until shoulder on gear (4) bottoms against inner race of bearing.
4. See [Figure 6-43](#). Tap in **new** seal (3) at threaded end of 5th gear.

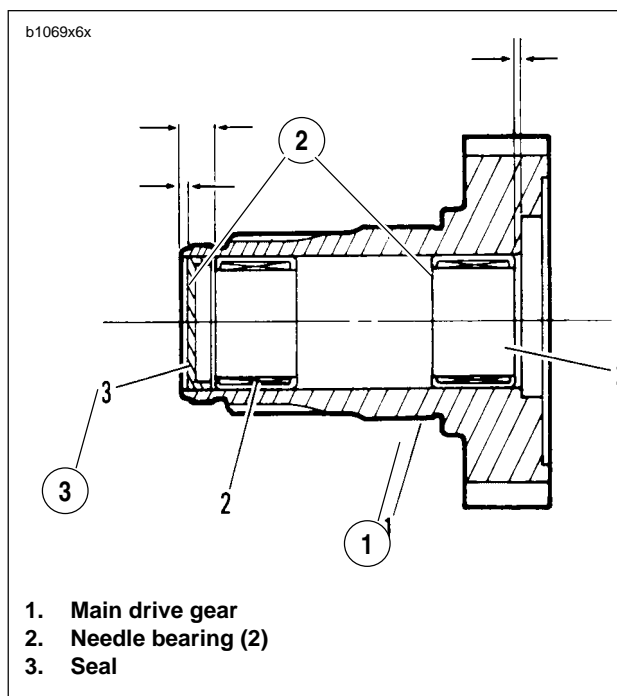


Figure 6-41. Lubricating Main Drive Gear Needle Bearings



1. Thrust washer
2. Bolt
3. Installer cup
4. 5th gear
5. Washer
6. Nut

Figure 6-42. Main Drive Gear Installation



1. Main drive gear
2. Needle bearing (2)
3. Seal

Figure 6-43. Main Drive Gear Assembly

REMOVAL

NOTE

See [Figure 6-46](#). Refer to *Transmission assembly right crank-case half*, for location of items discussed on this page.

1. Remove transmission assembly. See [6.7 TRANSMISSION DISASSEMBLY](#).
2. See [Figure 6-44](#). Remove main drive 5th gear. Use MAIN DRIVE GEAR REMOVER AND INSTALLER (Part No.HD-35316A). See [6.9 MAIN DRIVE GEAR](#).
3. At outside of case remove seal next to 5th gear bearing retainer. Remove retaining ring.
4. From inside transmission case drive bearings (5th gear, countershaft or shifter shaft) out of bores. Carefully tap bearings free by working around bearing diameter to keep bearing from skewing.

INSTALLATION

Mainshaft 5th Gear Ball Bearing

1. Locate MAIN DRIVE GEAR REMOVER AND INSTALLER (Part No. HD-35316-A). See [Figure 6-44](#). Place cross plate pins in appropriate holes in transmission case.
2. See [Figure 6-45](#). Insert bolt (2) through cross plate (1), **new** bearing (3), driver (4) and thrust bearing (5). Thread nut (6) on end of bolt. Tighten nut carefully until bearing is started in bore squarely. Tighten nut (6) until bearing is seated against shoulder in bore.
3. At outside of case install beveled retaining ring in groove inside bearing bore with beveled side facing outside.
4. Lubricate bearing with FORMULA+ Primary/Transmission Lubricant.

Countershaft Needle Bearing

1. Find a suitable bearing driver 1-1/4 in. (31.75 mm) in diameter.
2. From the outside of the case place the needle bearing open end first next to the bearing bore. Hold the driver squarely against the closed end of the bearing and tap the bearing into place. The bearing is properly positioned when it is driven inward flush or 0.030 in. (0.762 mm) below the outside surface of the case.
3. Lubricate bearing with FORMULA+ Primary/Transmission Lubricant.

Shift Drum Needle Bearing

1. Find a bearing driver 0.8125 in. (20.64 mm) in diameter.
2. From the outside of the case place the needle bearing, open end first, next to the bearing bore. Hold the driver squarely against the closed end of the bearing and tap the bearing into place. The bearing is properly positioned when driven inward flush or 0.030 in. (0.762 mm) below the outside surface.
3. Lubricate bearing with FORMULA+ Primary/Transmission Lubricant.

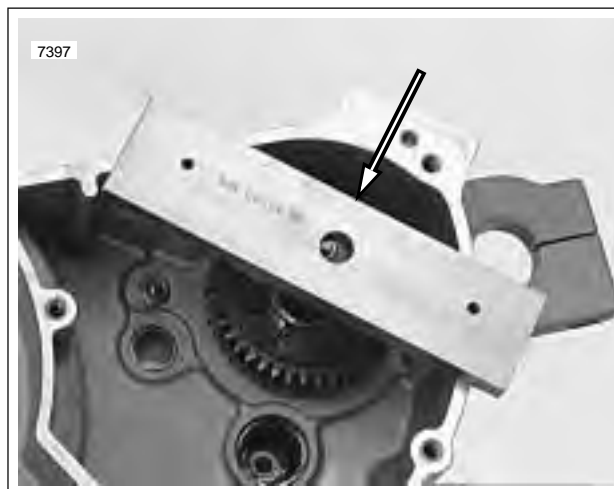
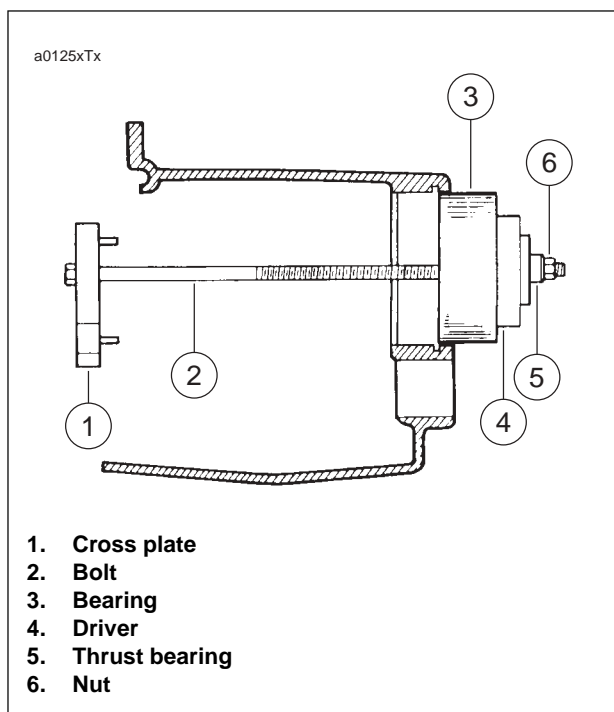


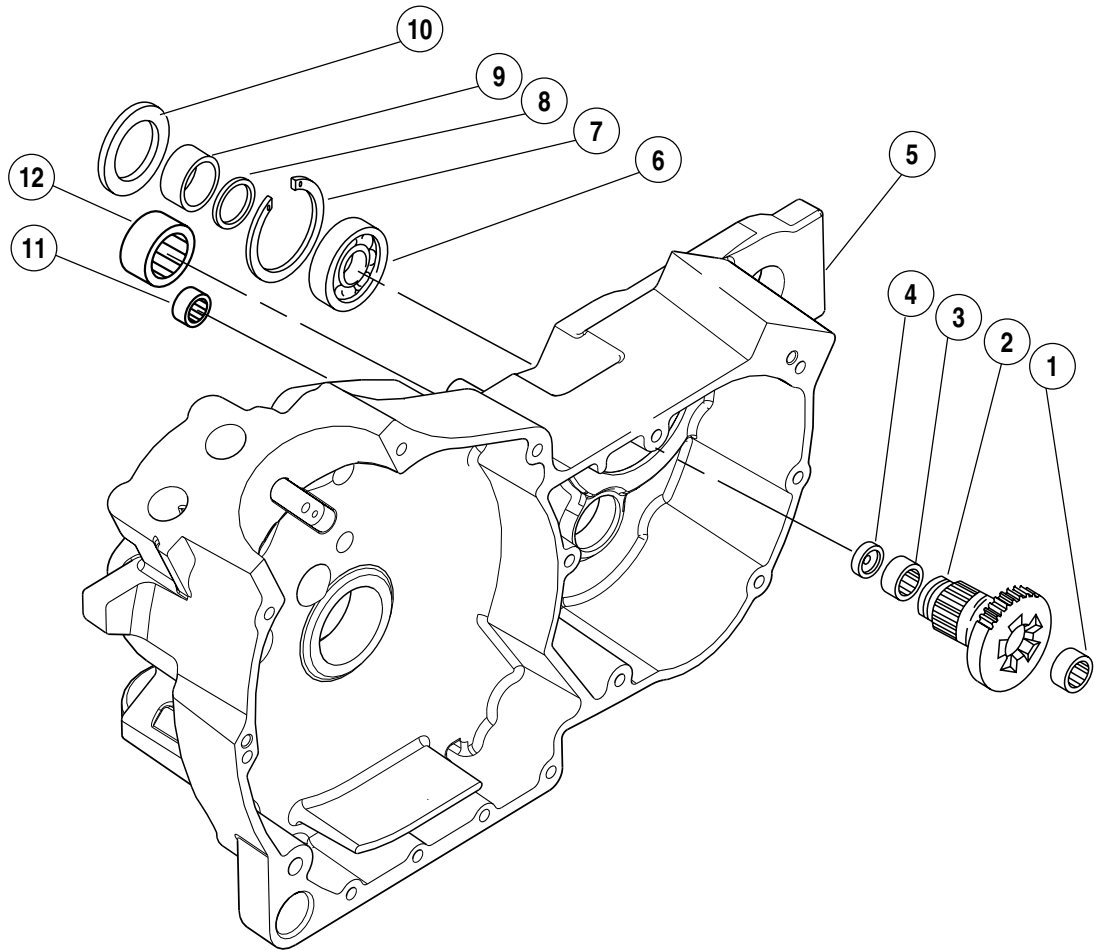
Figure 6-44. Mounting Cross Plate (Part No. B-43983)



1. Cross plate
2. Bolt
3. Bearing
4. Driver
5. Thrust bearing
6. Nut

Figure 6-45. Installing Mainshaft Ball Bearing

a0127x6x



1. Bearing (2)
2. Fifth gear mainshaft
3. Needle bearing (2)
4. Oil seal
5. Right crankcase half
6. Ball bearing
7. Retaining ring
8. Quad seal
9. Spacer
10. Oil seal
11. Bearing (closed end) shifter drum
12. Bearing (closed end) countershaft

Figure 6-46. Transmission Assembly Right Crankcase Half

REMOVAL

NOTE

See [Figure 6-49](#). Refer to transmission assembly left crankcase half, for location of items discussed on this page.

Mainshaft and Countershaft Bearings

1. See [6.6 TRANSMISSION CASE](#). Split crankcases in half.
2. See [SHIFTER FORKS AND DRUM DISASSEMBLY](#) under [6.7 TRANSMISSION DISASSEMBLY](#). Remove shifter forks and drum.
3. See [6.7 TRANSMISSION DISASSEMBLY](#). Remove countershaft and mainshaft.
4. Inspect the mainshaft and countershaft ball bearings for pitting, scoring, discoloration or other damage.
5. See [Figure 6-47](#). If bearing replacement is required, remove retaining rings (1, 2). Press out bearings (3, 4) from the inside of the crankcase.

Shift Drum Bushing

Inspect the shifter drum bushing for pitting, scoring, discoloration or excessive wear. If bushing requires replacement press bushing out of crankcase from either side.

INSTALLATION

Mainshaft and Countershaft Bearings

1. Place crankcase on press with inside surface of crankcase downward.
2. Lay bearing squarely over bore with printed side of bearing upward. Place section of pipe or tubing (slightly smaller than outside diameter of bearing) against outer race. Press bearing into bore until bearing bottoms against shoulder.
3. Install **new** retaining ring with beveled side facing away from bearing.

Shift Drum Bushing

1. Place crankcase on press with outside surface of crankcase downward.
2. See [Figure 6-48](#). Lay bushing squarely over bore. Locate socket or pipe that is slightly larger than diameter of bushing. Place socket or pipe on bushing and press into bore until bushing is flush with or 0.020 in. (0.508 mm) below inside surface. If using a pressing tool larger than diameter of bushing, the pressing tool will bottom against crankcase when bushing is flush with top surface.

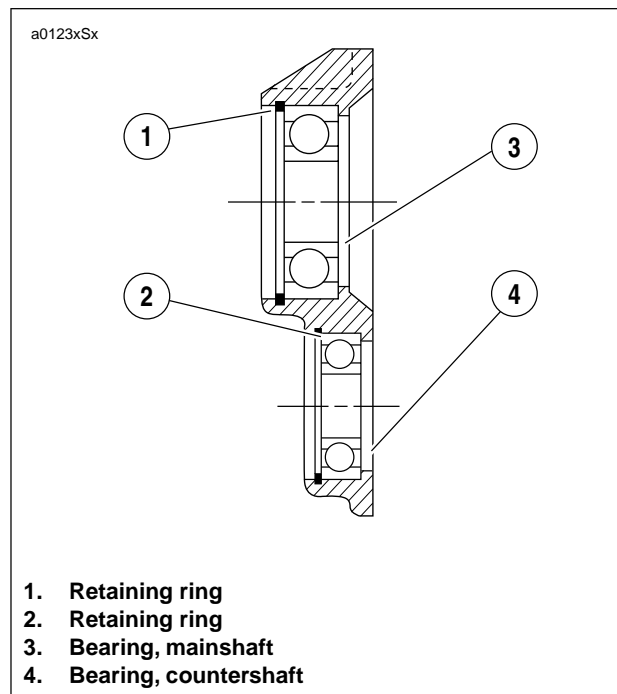


Figure 6-47. Ball Bearing Assembly

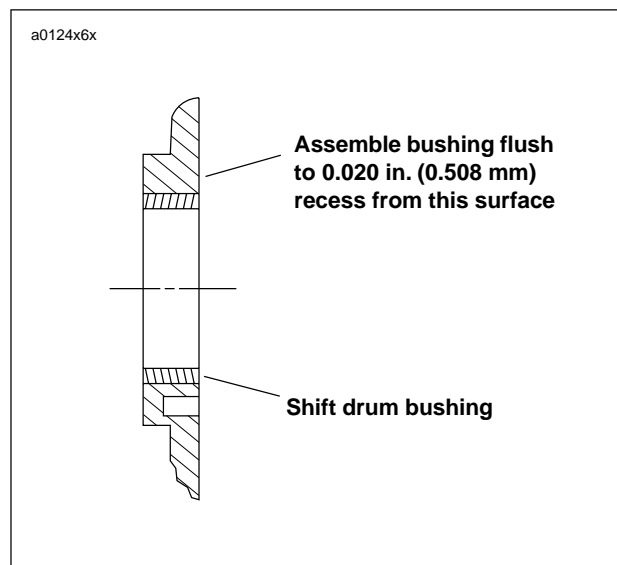


Figure 6-48. Shift Drum Bushing Assembly

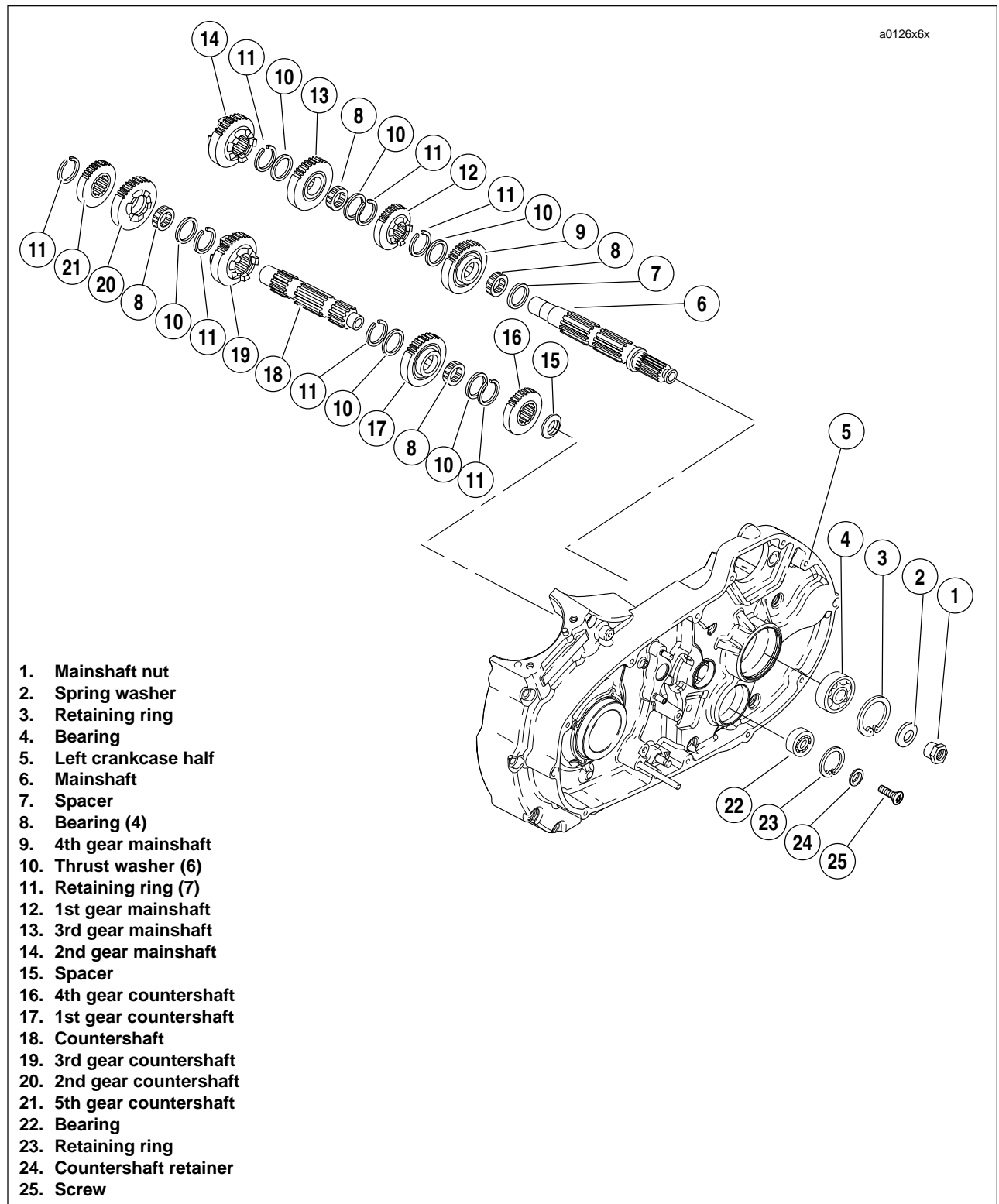


Figure 6-49. Transmission Assembly Left Crankcase Half

INSTALLATION

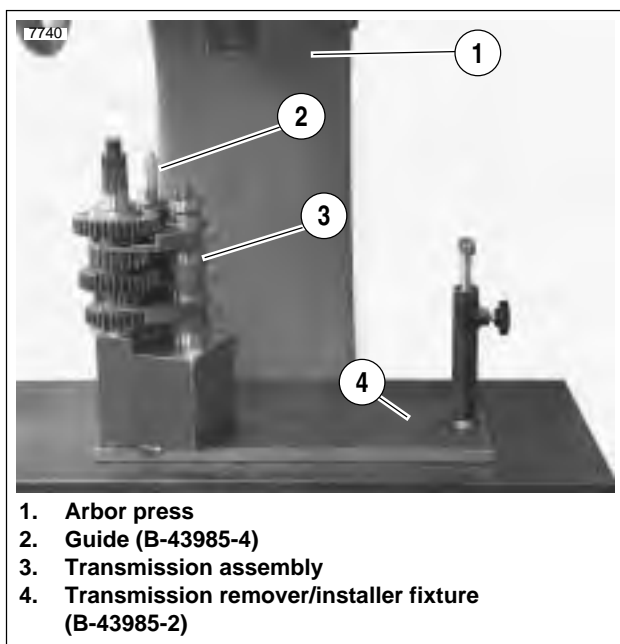
NOTES

- If only transmission components were serviced, the fly-wheel assembly should already be in place.
- If flywheels and crankcases were serviced, install the fly-wheel assembly before re-installing the transmission assembly.

Verify that all parts have been properly installed, as described earlier in this section under:

- 6.9 MAIN DRIVE GEAR
- 6.8 TRANSMISSION ASSEMBLY
- 6.11 LEFT CRANKCASE BEARINGS
- 6.10 RIGHT TRANSMISSION CASE BEARINGS

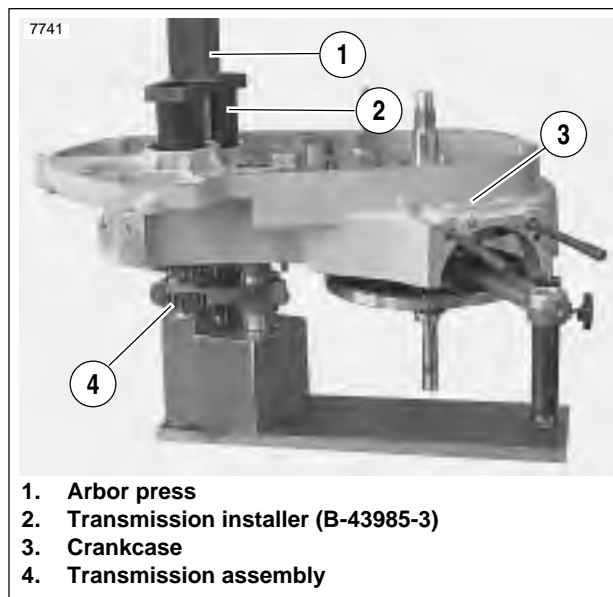
1. Remove left crankcase half from engine stand.



1. Arbor press
2. Guide (B-43985-4)
3. Transmission assembly
4. Transmission remover/installer fixture (B-43985-2)

Figure 6-50. Transmission Assembly

2. See Figure 6-50. Place transmission assembly onto TRANSMISSION REMOVER/INSTALLER FIXTURE (Part no. B-43985-2) on arbor press.
 - a. Install countershaft GUIDE (Part No. B-43985-4).
 - b. See Figure 6-51. Place left case half over transmission assembly and install TRANSMISSION INSTALLER (Part no. B-43985-3) into crankcase.
3. See Figure 6-51. Press crankcase into transmission assembly until it bottoms out.
4. Remove transmission assembly and left crankcase half from fixture.



1. Arbor press
2. Transmission installer (B-43985-3)
3. Crankcase
4. Transmission assembly

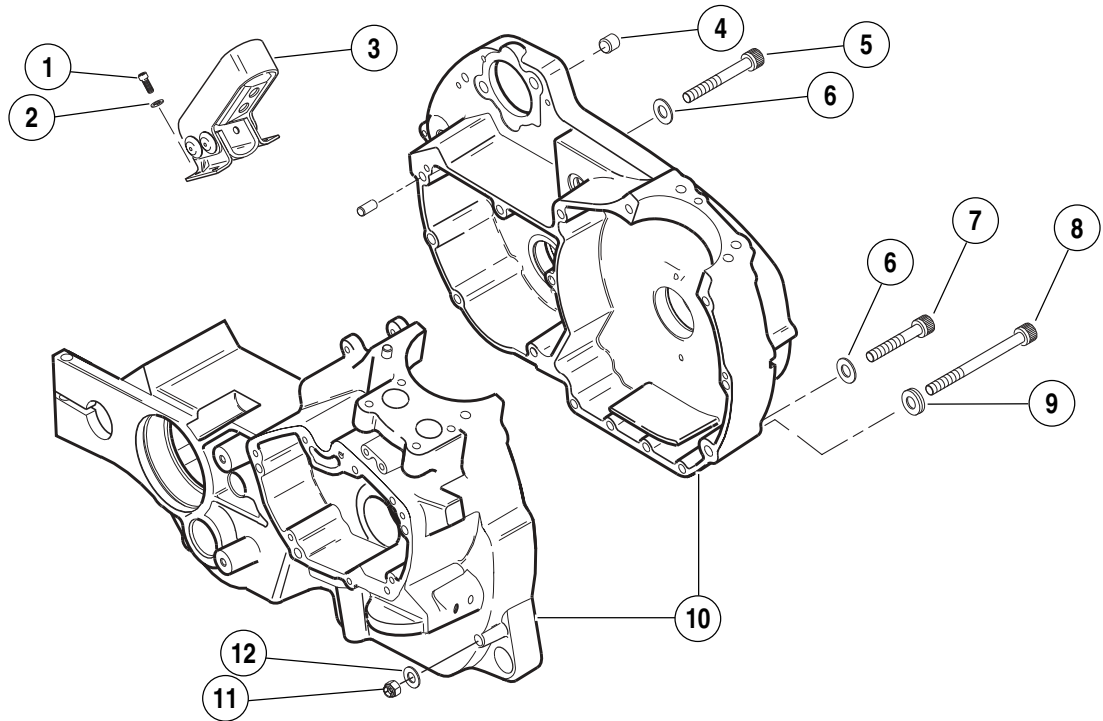
Figure 6-51. Transmission Remover/Installer on Fixture



Figure 6-52. Crankcase Halves

5. See Figure 6-52. Assemble crankcase halves together.
 - a. Apply a thin coat of DOW CORNING SILASTIC or 3-M 800 sealant to crankcase joint faces.
 - b. See CRANKCASE HALVES. Attach crankcase halves in torquing sequence shown.
 - c. Apply several drops of LOCTITE 262 (red) to last few threads.
 - d. See Figure 6-53. Tighten 1/4-in. fasteners to 80-110 in-lbs (9.0-12.4 Nm)
 - e. Tighten 5/16-in. fasteners to 15-19 ft-lbs (20-25 Nm).

a0484x6x



1. Screw (4)
2. Washer (4)
3. Rear isolator
4. Dowel pin
5. Hex socket head screw (9)
6. Washer (14)
7. Bottom case t40 TORX bolt (5)
8. Hex socket head screw (1)
9. Spacer (1)
10. Crankcase set
11. Nyloc, hex locknut
12. Washer (1)

Figure 6-53. Crankcase Hardware

ADJUSTMENT

1. See Figure 6-54. Lift pawl over drum pins and place shifter shaft assembly on studs at transmission case. Loosely install a washer and locknut on each stud.

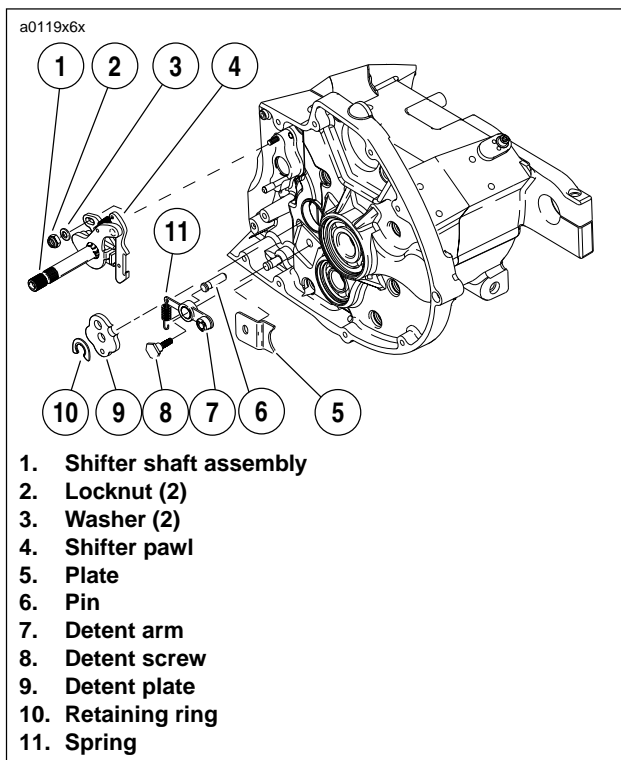


Figure 6-54. Installing Shifter

2. Install detent plate.
 - a. Place detent plate (9) over drum pins.
 - b. Rotate plate until blind holes in plate align with pins in end of shifter fork drum.
 - c. Install **new** retaining ring (10) using SHIFT DRUM RETAINING RING INSTALLER (Part No. HD-39151).
3. Verify that retaining ring is fully engaged with drum groove.
4. Attach loop of spring (11) over and into groove in pin (6).

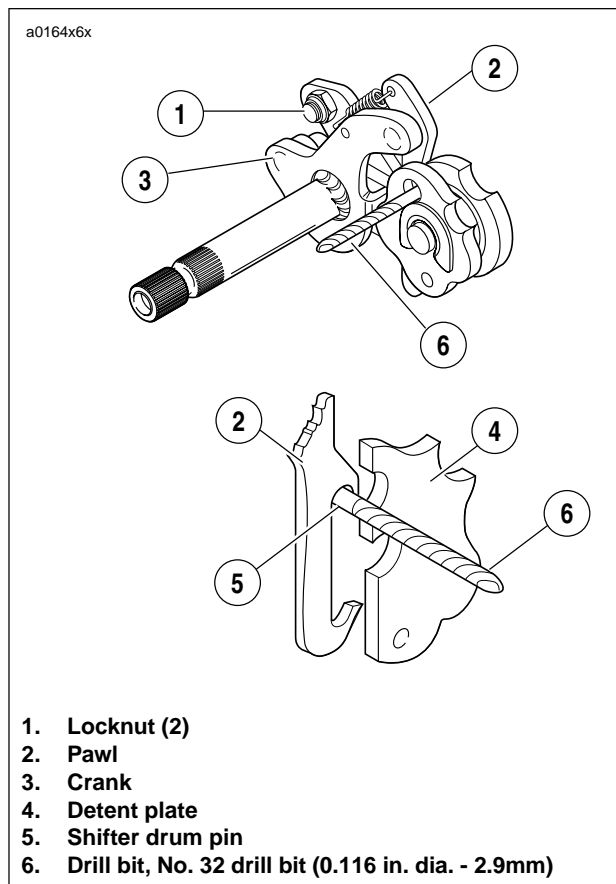


Figure 6-55. Shifter Shaft Assembly Alignment

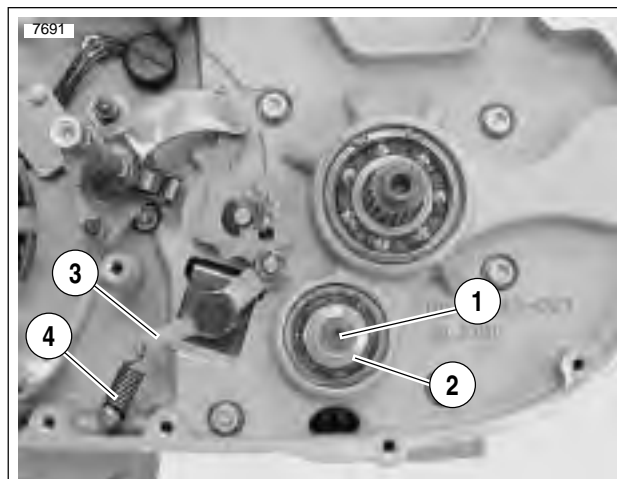
5. See Figure 6-55. Align shifter shaft.
 - a. Place transmission in third gear.
 - b. Place a No. 32 drill bit (0.116 in. dia.) through hole in detent plate (4), and between pawl (2) and drive pin at end of shifter drum shaft.
 - c. Push down top of crank (3) to remove all clearance between pawl and drill bit; this will correctly align pawl to shift drum pins (do not push down with too great a force, as this might cause the shifter drum to rotate).
 - d. With bit in place, tighten shifter shaft assembly bottom locknut (1) first to 90-110 **in-lbs** (10-12 Nm). Then, tighten shifter shaft assembly top locknut (1) to the same torque.
 - e. **Remove drill bit.**

6. See [Figure 6-46](#). Place **new** quad ring over threaded end of fifth gear, and position next to the gear taper. Install spacer over threaded end of fifth gear with chamfered end toward quad ring. Slide spacer up against bearing.
7. Install seal.
 - a. Coat lips of seal with FORMULA+ Primary/Transmission Lubricant.
 - b. Position seal over spacer with lips of seal toward case.
 - c. Use MAIN DRIVE GEAR SEAL INSTALLER (Part No. HD-41496) to gently tap seal into bore of case until the outside of seal is flush with outer edge of bore.

NOTE

It is acceptable to recess seal to about 0.030 in. (0.762 mm) below outer edge of bore. Seal will be controlled by tool.

8. See [Figure 6-56](#). Position retention collar next to end of counter shaft with beveled side facing outward.
 - a. Apply several drops of LOCTITE 243 (blue) to last few threads.
 - b. Insert screw (1) through retention collar (2) and thread into end of shaft.
 - c. Place transmission in gear, and tighten T/ORX screw (1) to 13-17 ft-lbs (18-23 Nm).



1. TORX screw
2. Retention collar
3. Detent roller arm
4. Spring

Figure 6-56. Countershaft Retainer

REMOVAL

1. See [Figure 6-57](#). Place transmission in first gear. Remove two socket head screws (5) and lockplate (4).

NOTE:

Transmission sprocket nut has left-hand threads. Turn nut clockwise to loosen and remove from main drive gear shaft.

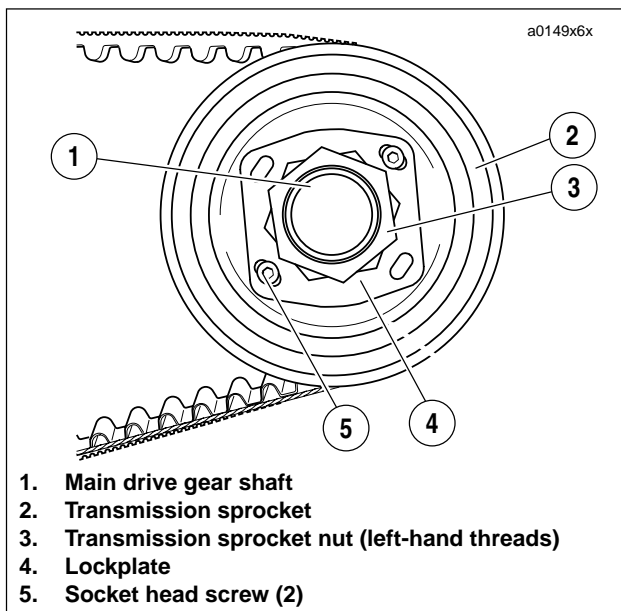


Figure 6-57. Transmission Sprocket

2. See [Figure 6-57](#). Remove transmission sprocket nut (3) from main drive gear shaft (1).
3. See [Figure 6-58](#). Secure pulley using SPROCKET LOCKING TOOL (Part No. B-43982).

INSTALLATION

1. See [Figure 6-57](#). Install transmission sprocket (2) with secondary drive belt onto main drive gear shaft (1).
2. Place transmission in neutral.
3. Apply a few drops of LOCTITE 262 (red) to the **left-hand threads** of transmission sprocket nut (3) and lightly coat the washer-faced side with clean H-D 20W50 engine oil. Wipe off any excess oil.
4. Position nut with washer-faced side facing transmission sprocket. Turn the nut **counterclockwise** to install it onto main drive gear shaft.

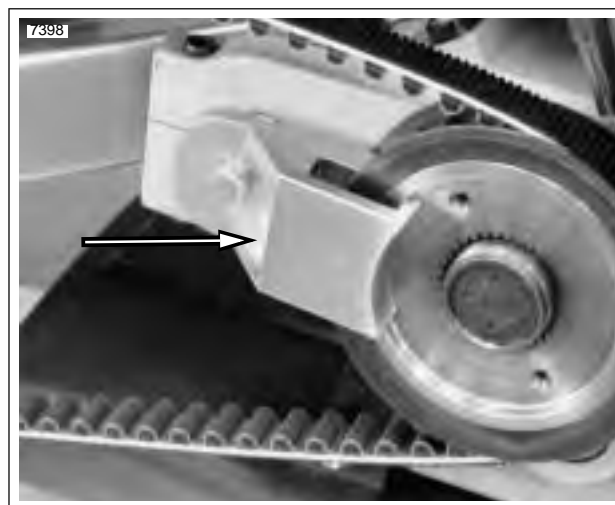
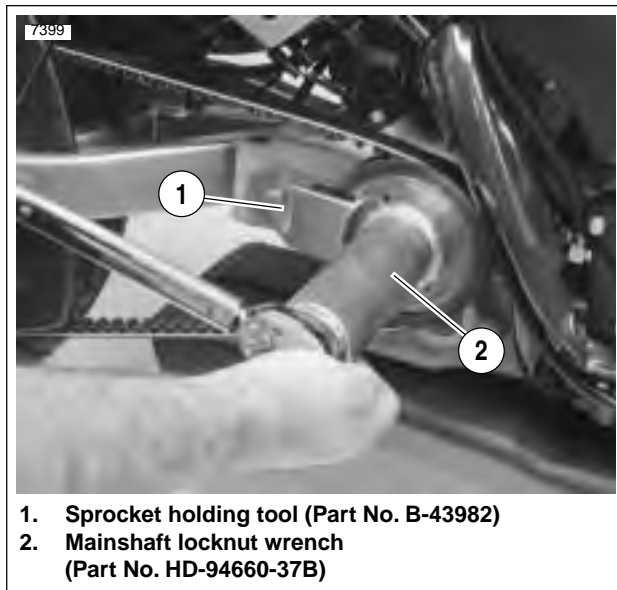


Figure 6-58. Sprocket Locking Tool (Part No. B-43982)

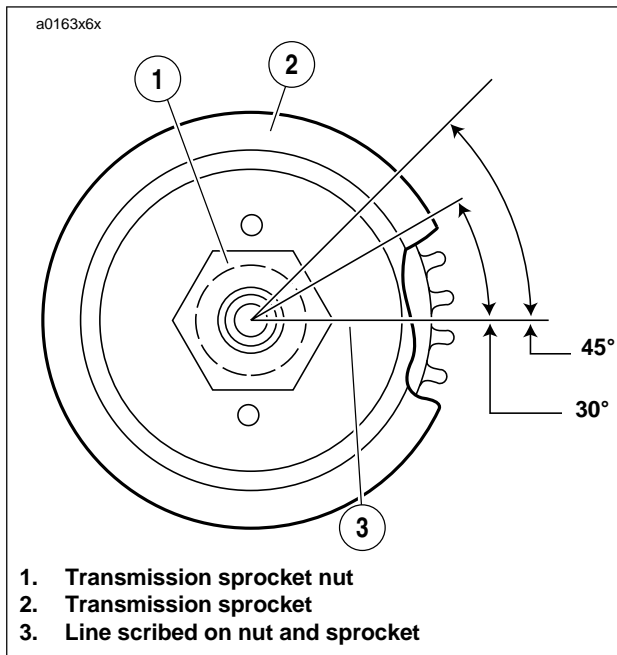
5. See [Figure 6-58](#). Install SPROCKET HOLDING TOOL (1) (Part No. B-43982) as shown.



1. Sprocket holding tool (Part No. B-43982)
2. Mainshaft locknut wrench (Part No. HD-94660-37B)

Figure 6-59. Transmission Sprocket Tightening

6. See [Figure 6-59](#). Use MAINSHAFT LOCKNUT WRENCH (Part No. HD-94660-37B) and a torque wrench to tighten sprocket nut to 50 ft-lbs (68 Nm) INITIAL torque, ONLY.



1. Transmission sprocket nut
2. Transmission sprocket
3. Line scribed on nut and sprocket

Figure 6-60. Aligning Transmission Sprocket

7. See [Figure 6-60](#). Scribe a line on the transmission sprocket nut and continue the line on the transmission sprocket as shown.
8. Tighten the transmission sprocket nut an additional 30°-40°.
9. See [Figure 6-57](#). Install lockplate over nut so that two of lockplate's four drilled holes (diagonally opposite) align with sprocket's two tapped holes.

NOTES

- The lockplate has four screw holes and can be turned to either side, so you should be able to find a position without having to additionally tighten the nut. If you cannot align the screw holes properly, the nut may be additionally **TIGHTENED** until the screw holes line up, but do not exceed 45° as specified above. Never **LOOSEN** nut to align the screw holes.
- See [Figure 6-60](#). If lockplate will not align with holes, tighten nut to 45° maximum.

IMPORTANT NOTE

Maximum allowable tightening of sprocket nut is 45° of counterclockwise rotation, after initially tightening to 50 ft-lbs. Do not loosen sprocket nut while attempting to align the screw holes. If you cannot align lockplate and sprocket screw holes, nut may be additionally tightened 45° as specified above. Tightening too much or too little may cause the nut to come loose during vehicle operation.

10. If you cannot align lockplate and sprocket screw holes, nut may be additionally tightened until screw holes align.
11. See [Figure 6-57](#). Install two socket head screws through aligned holes of lockplate and into tapped holes of sprocket. Tighten to 90-110 **in-lbs** (10-12 Nm).

NOTE

The original equipment socket head screws (5) have thread-locking compound applied to them. Since this compound remains effective for about three removal/installation cycles, the original screws may be reused up to three times. After the third removal/installation cycle, replace both screws with **new** screws identical to the original.

12. Install the remaining removed components in the reverse order of the removal procedures. See the procedures listed in the respective component sections.
13. Fill transmission to proper level with fresh lubricant. See [1.10 TRANSMISSION/PRIMARY FLUID](#).

NOTES

SUBJECT	PAGE NO.
7.1 Specifications	7-1
7.2 Ignition System	7-3
7.3 Diagnostic Charts	7-6
7.4 Throttle Position Sensor (TP Sensor)	7-12
7.5 Bank Angle Sensor	7-13
7.6 Ignition/Headlamp Key Switch	7-14
7.7 Auto-Enrichener	7-16
7.8 Ignition Module and Cam Position Sensor	7-18
7.9 Ignition Coil	7-23
7.10 Spark Plug Cables	7-25
7.11 Starter/Ignition Interlock	7-26
7.12 Diodes	7-33
7.13 Charging System	7-34
7.14 Alternator	7-40
7.15 Voltage Regulator	7-43
7.16 Battery	7-44
7.17 Headlamp	7-49
7.18 Tail Lamp	7-51
7.19 Turn Signals	7-52
7.20 Turn Signal Flasher	7-54
7.21 Handlebar Switches	7-55
7.22 Horn	7-57
7.23 Neutral Indicator Switch	7-58
7.24 Fuses And Circuit Breakers	7-59
7.25 Electronic Speedometer	7-60
7.26 Speedometer Sensor	7-62
7.27 Speedometer Performance Check	7-63
7.28 Indicators	7-68
7.29 Main Wiring Harness	7-69

Table 7-1. Battery Specifications

Rating	12 VDC/12AH/200CCA
Type	Sealed

Table 7-2. Alternator Specifications

AC Voltage Output	19-26 VAC per 1000 engine RPM
Stator Coil Resistance	0.2-0.4 Ohms

Table 7-3. Regulator Specifications

Voltage Output @ 75°F	14.3-14.7 VDC
Amperes @ 3600 RPM	22 Amps

Table 7-4. Spark Plug Specifications

Spark Plug	10R12A	
Size	12 mm	
Gap	0.035 in.	0.9 mm
Torque	11-18 ft-lbs	14.9-24.4 Nm

Table 7-5. Ignition Coil Resistance

Primary Winding	0.4-0.6 ohms
Secondary Winding	7,720-9,440 ohms

Table 7-6. Spark Plug Cable Resistance

Spark Plug Cable	2,375-5,833 ohms
------------------	------------------

Table 7-7. Ignition Timing Spark Occurrence

RPM	TP SENSOR	
	LOW VOLTAGE (PT)	HIGH VOLTAGE (WOT)
1200 RPM (Idle)	20° BTDC	18° BTDC
3000 RPM	30° BTDC	18° BTDC
6000 RPM	45° BTDC	35° BTDC
Curve Switch Point	TP Sensor Input 2.4V	
Rev Limit	6500 RPM	

Table 7-8. Electrical Specifications

ELECTRICAL SYSTEM	AMPERES
Main Circuit Breaker	30
Ignition Fuse	7.5
Light Fuse	15
Accessory Fuse	7.5
System Fuse	15
Key Switch Fuse	15

Table 7-9. Bulb Specifications

LAMP DESCRIPTION		BULBS REQUIRED	WATTS	AMPS	PART NUMBER
Headlamp	High/Low	1	60/55	4.68/3.12	67713-86
Marker Lamps	Tail/Stop Lamp	1	5/21	0.42/1.75	68169-90A
	Turn Signal Lamp, Front and Rear (1 bulb each)	4	10	0.74	Y0042.K
Indicator Lamps (in speedometer)	High Beam Indicator, Turn Signal Indicator	Non-replaceable LEDs			
	Oil Pressure Indicator, Neutral Indicator				

TORQUE VALUES

ITEM	TORQUE		NOTES
Bank angle sensor	25-27 in-lbs	2.8-3.1 Nm	Page 7-13
Battery terminal bolts	72-96 in-lbs	8-11 Nm	Page 7-13
Circuit breaker bracket mounting screw	25-27 in-lbs	2.8-3.1 Nm	Page 7-31
Circuit breaker metal nuts	15-18 in-lbs	1.7-2.0 Nm	Page 7-31
Circuit breaker nylon acorn	1-3 in-lbs	0.1-0.3 Nm	Page 7-31
Headlamp housing mounting screws	12-14 ft-lbs	16-19 Nm	Page 7-15
Ignition coil mounting screws	48-72 in-lbs	5-8 Nm	Page 7-24
Ignition key switch bolts	48-72 in-lbs	5-8 Nm	Page 7-15
Ignition module plate screws	10-20 in-lbs	1-2 Nm	Page 7-20
Neutral indicator switch	36-60 in-lbs	4-7 Nm	Loctite 243 (blue), Page 7-58
Rotor cup mounting fasteners	43-53 in-lbs	5-6 Nm	Page 7-20
Rotor mounting bolts	90-110 in-lbs	10-12 Nm	Loctite 243 (blue), Page 7-42
Sidestand switch fasteners	30-36 in-lbs	3-4 Nm	Page 7-30
Spark plug	11-18 ft-lbs	15-24 Nm	Page 7-3
Speedometer sensor screw	80-100 in-lbs	9-11 Nm	Page 7-62
Stator mounting screws	30-40 in-lbs	3-5 Nm	T-27 TORX with retaining compound, replace after removal, Page 7-42
Switchgear housing screws, left side	25-33 in-lbs	3-4 Nm	Metric, Page 7-56
Switchgear housing screws, right side	25-33 in-lbs	2.8-3.7 Nm	Metric, Page 7-55
Tail lamp mounting locknuts	25-28 in-lbs	2.6-3.2 Nm	Metric, Page 7-51
Throttle position sensor fasteners	12-23 in-lbs	2-3 Nm	Page 7-12
Timing inspection hole plug	10-15 ft-lbs	14-20 Nm	Page 7-21
Voltage regulator mounting fasteners	48-72 in-lbs	5-8 Nm	Page 7-43

GENERAL

See [Figure 7-1](#). The vehicle uses a breakerless inductive-discharge ignition system. The system has both a primary and secondary circuit. The primary circuit consists of the battery, ignition switch, primary coil winding, computerized ignition timer and associated wiring. The secondary circuit consists of the secondary coil, spark plug and associated wiring.

The computerized ignition system contains five assemblies.

Ignition Module

The ignition module is mounted in the gear case cover. The module has two functions. First, it computes the spark advance for proper ignition timing. Second, it opens and closes the low-voltage circuits between the battery and ignition coil to produce high-voltage discharge to the spark plug. The ignition module on the P3 Blast also contains an integrated cam position sensor.

Above 6500 RPM, the ignition module will automatically reduce power to prevent over revving.

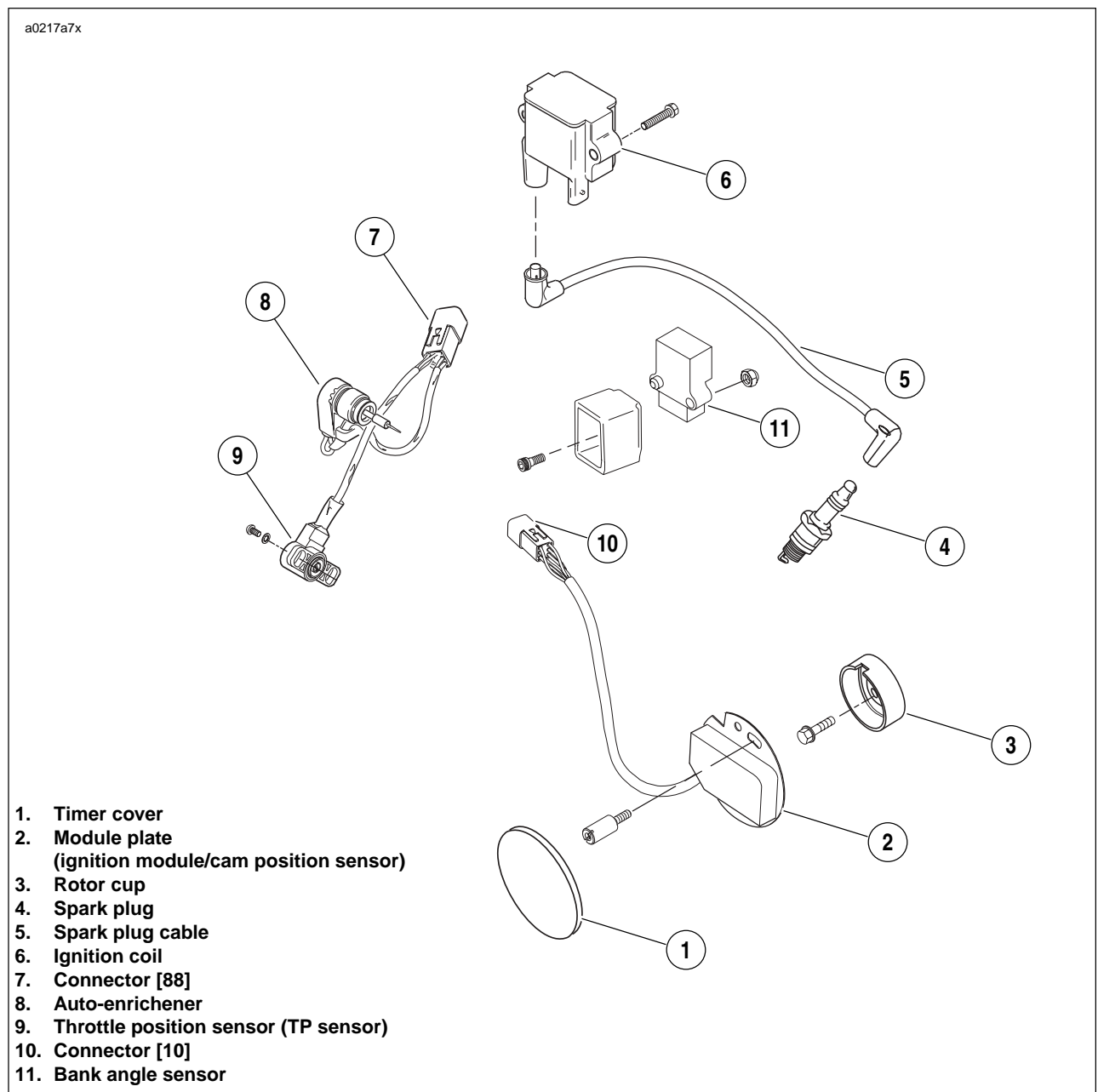


Figure 7-1. Ignition System Components

The ignition module contains all the solid-state components used in the ignition system. The dwell time is fixed. The ignition module has added protection against transient voltages, continuous reverse voltage protection and damage due to jump starts. The system will operate down to 6.0 VDC. The ignition module is fully enclosed to protect it from vibration, dust, water and oil. The module is not repairable. Replace the unit if it fails.

The ignition module is programmed with two spark advance curves to meet varying engine loads. The ignition module selects the proper curve based on TP sensor output voltage which is continuously monitored. This system ensures correct timing to suit starting and high-speed requirements.

A single ignition coil fires the spark plug at the end of the compression stroke (no waste spark), thereby igniting the air/fuel mixture.

Throttle Position Sensor (TP Sensor) and Auto-Enrichener

The throttle position sensor (TP Sensor) is attached to the throttle shaft on the carburetor. The TP sensor voltage is high when the throttle is opening during acceleration and under high engine load conditions and the voltage is low during deceleration and under low engine load conditions. The high or low voltage signal from the TP sensor is communicated to the ignition module which selects the correct spark advance curve (change between high and low curve takes place at TP Sensor input 2.4V).

The low voltage signal curve (throttle less than 1/2 open, <2.4V TP Sensor input), selected for maximum spark advance under normal light-load cruising conditions, provides improved fuel economy and performance. The high voltage signal curve (throttle more than 1/2 open, >2.4V TP Sensor input) minimizes spark knock while maintaining performance under high-load conditions (acceleration and highway driving).

The auto-enrichener is located on the carburetor and controls the cold idle speed of the motorcycle and enriches the air/fuel mixture. The auto-enrichener circuit is grounded and operative for 2-5 minutes after the motorcycle is started. The ground is completed by the ignition module.

Bank Angle Sensor

The bank angle sensor provides input to the ignition module on whether or not the vehicle lean angle is greater than 55 degrees. If vehicle lean angle exceeds 55 degrees, the bank angle sensor will shut off power to the ignition.

Rotor and Cam Position Sensor

The rotor and cam position sensor (cam position sensor is integrated with the ignition module) are located in the gear-case cover on the right side of the motorcycle. The rotor is mounted on the camshaft and operates at one-half crankshaft speed. As the rotor turns, a slot in its outside diameter breaks the magnetic field of a Hall-effect device mounted on the cam position sensor. The output of the Hall-effect device is a logic-type signal that corresponds to the timing information from the spinning rotor. This technique gives accurate timing information down to "0" speed.

The ignition system produces a spark near top dead center (TDC) for starting. At RPM's and loads above this, the system produces a spark 0°-45° before TDC. The whole timing program can be shifted by mechanical rotation of the integrated

ignition module plate. See [1.19 IGNITION TIMING AND IDLE SPEED ADJUSTMENT](#).

See the wiring diagrams at the end of this section for additional information on ignition system circuits.

TROUBLESHOOTING

For poor performance, poor fuel economy or excessive ping-ing, see [DRIVABILITY TROUBLESHOOTING](#) on Page 7-10. Also refer to Table 4-1 in Section 4 for Fuel System Troubleshooting.

For incorrect idle speed, see [DRIVABILITY TROUBLESHOOTING](#) on page 7-15.

If the engine will not start, or if hard starting or missing indicates a faulty operating ignition system, perform the tests listed below.

Check for Ignition Spark

1. Remove seat and fuel tank. See Sections 2 and 4.
2. Disconnect spark plug cable from spark plug. Check condition of plug and cable. Clean or replace as necessary. See [7.10 SPARK PLUG CABLE](#).
3. Install SPARK PLUG TESTER (HD-26792) to spark plug cable end.
4. Turn ignition key switch to IGN and engine stop switch to ON and pull in clutch lever.
5. With transmission in neutral, press electric starter button. Check for a spark across plug electrode gap.
 - a. If a spark is produced, problem is not in electronic system or coil. Check carburetion, enrichener and spark plug.
 - b. If no spark is produced, check battery voltage and battery connection. Battery voltage must be at least 12.6 VDC. Charge battery if voltage is low.
6. Verify that the ground strap from the front isolator to the frame is in good condition. If there is still no spark, then perform the tests under [NO IGNITION SPARK](#).

No Ignition Spark

See [Figure 7-2](#). To conduct the following tests, it will be necessary to assemble a set of jumper wires.

Cut two wires of ample length to reach from a good ground connection to the negative terminal of the coil primary. If a suitable capacitor is not available, use a condenser (such as the type used in earlier breaker point ignition systems).

When conducting Step 5 of the previous spark tests, use the SPARK PLUG TESTER (HD-26972). During the testing procedures, check for spark across the spark plug electrodes.

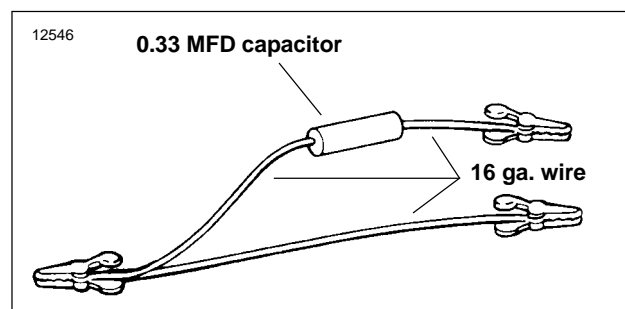


Figure 7-2. Test Jumper

a0582a7x

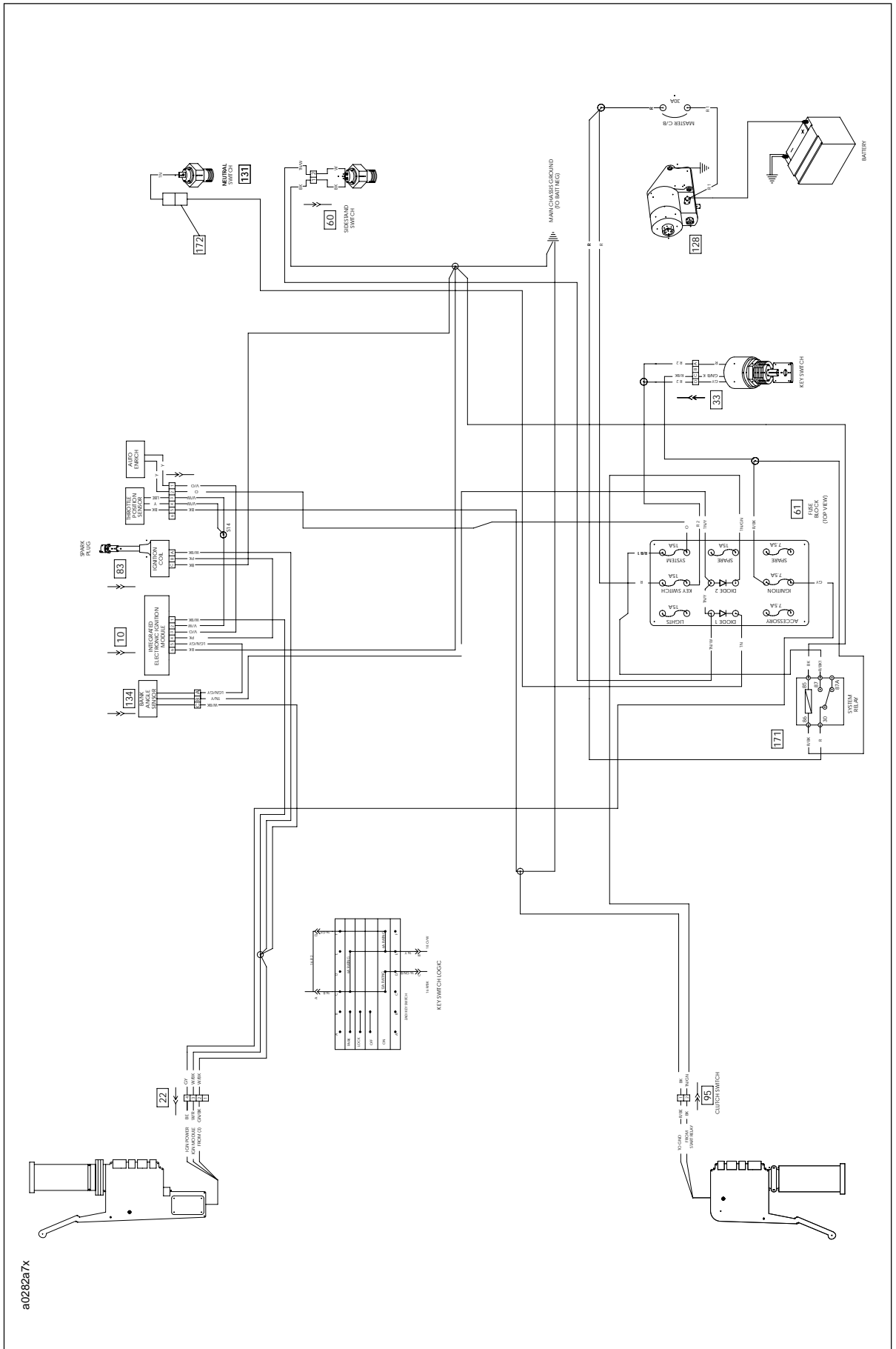
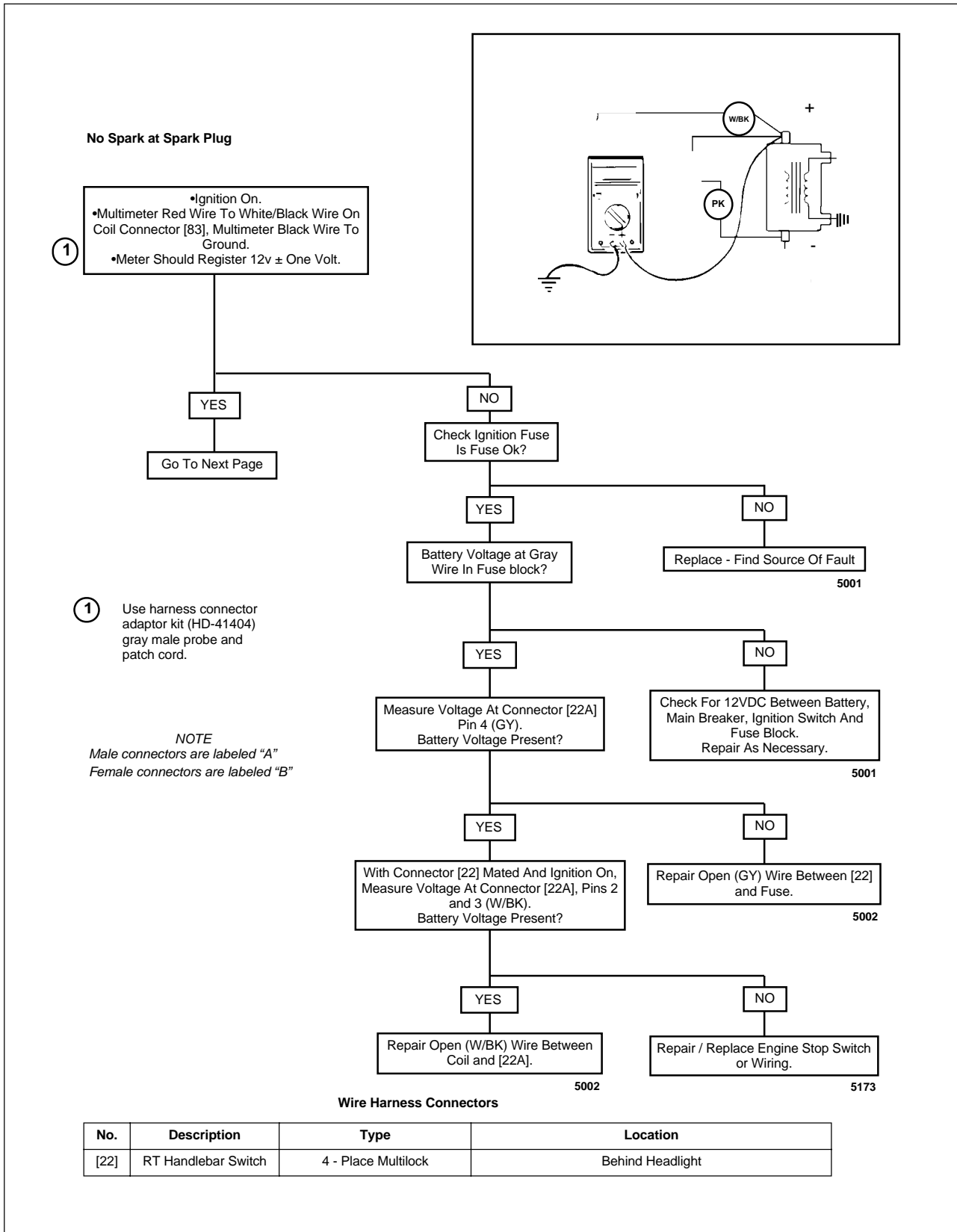


Figure 7-3. Ignition System Circuit



Wire Harness Connectors

No.	Description	Type	Location
[22]	RT Handlebar Switch	4 - Place Multilock	Behind Headlight

Figure 7-4. No Spark At Spark Plug

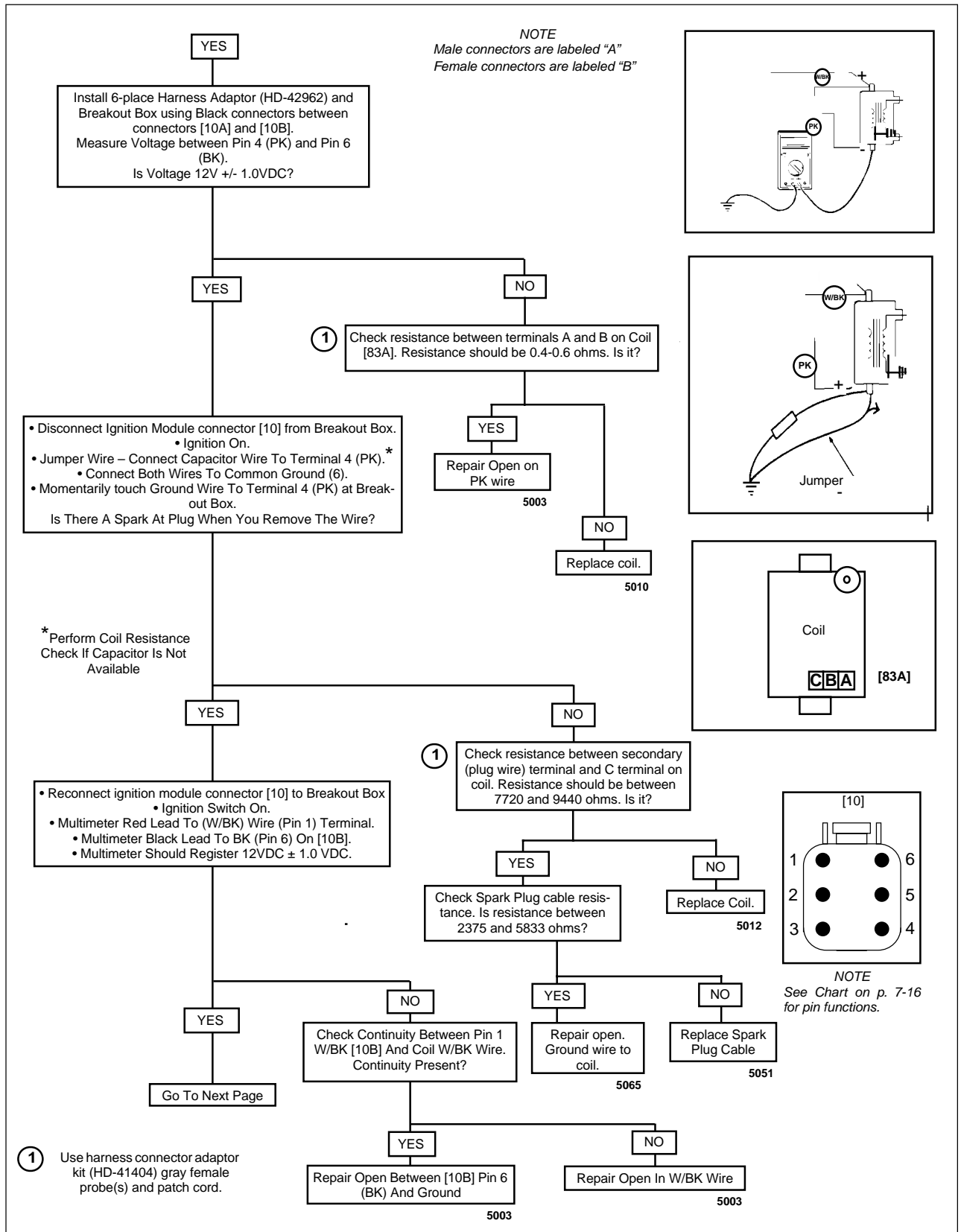


Figure 7-5. No Spark At Spark Plug

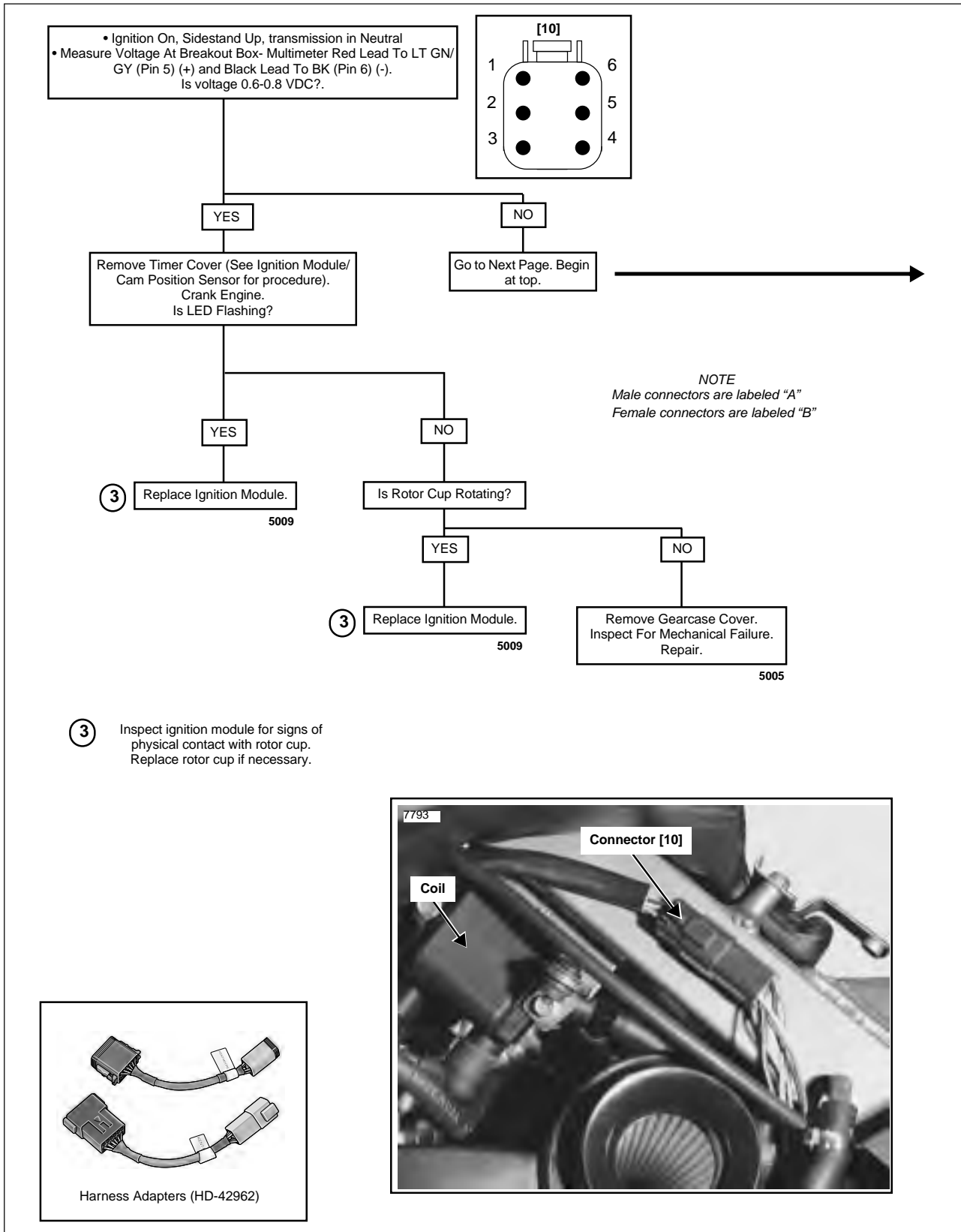


Figure 7-6. No Spark At Spark Plug

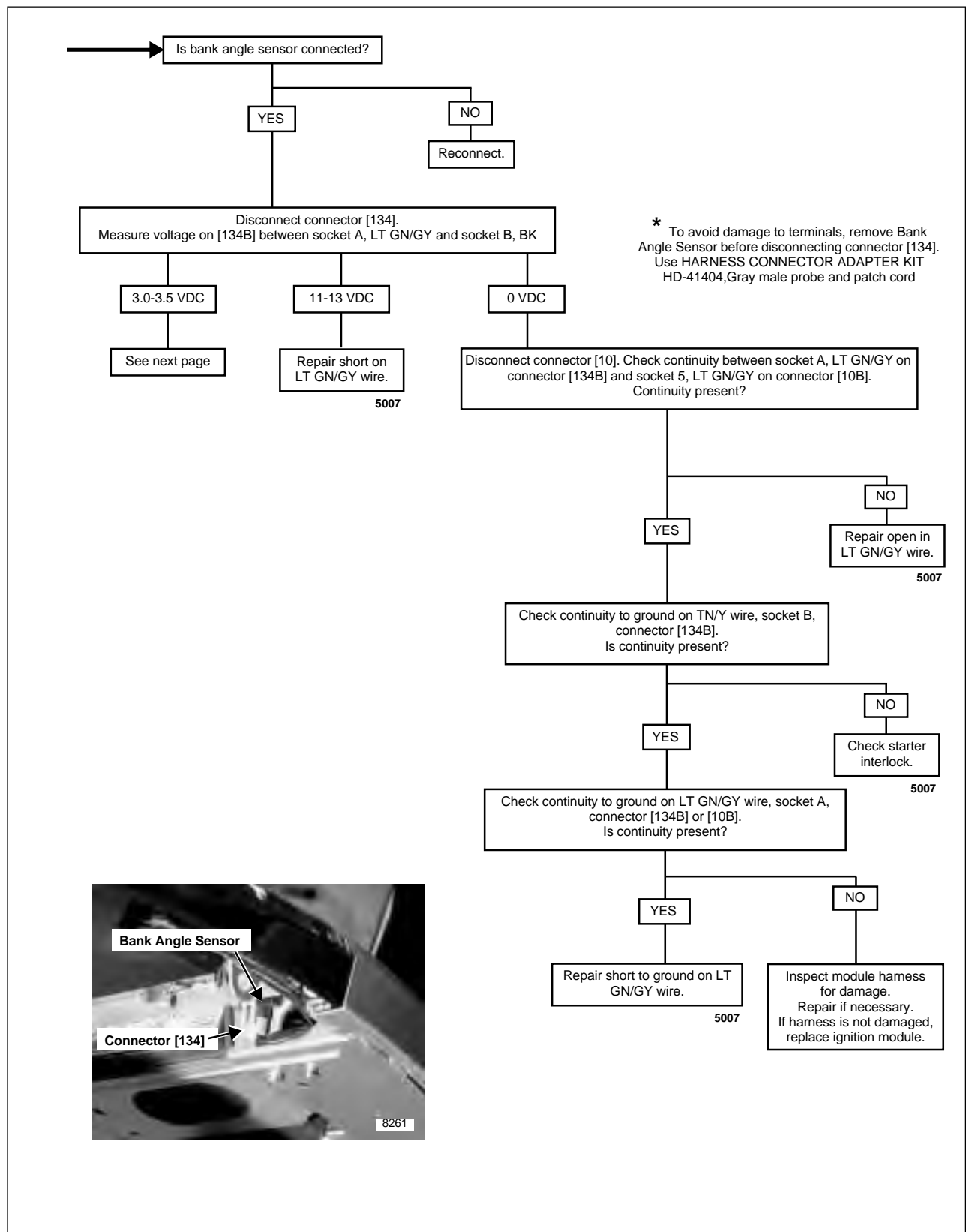


Figure 7-7. Continuous or No Spark At Spark Plug

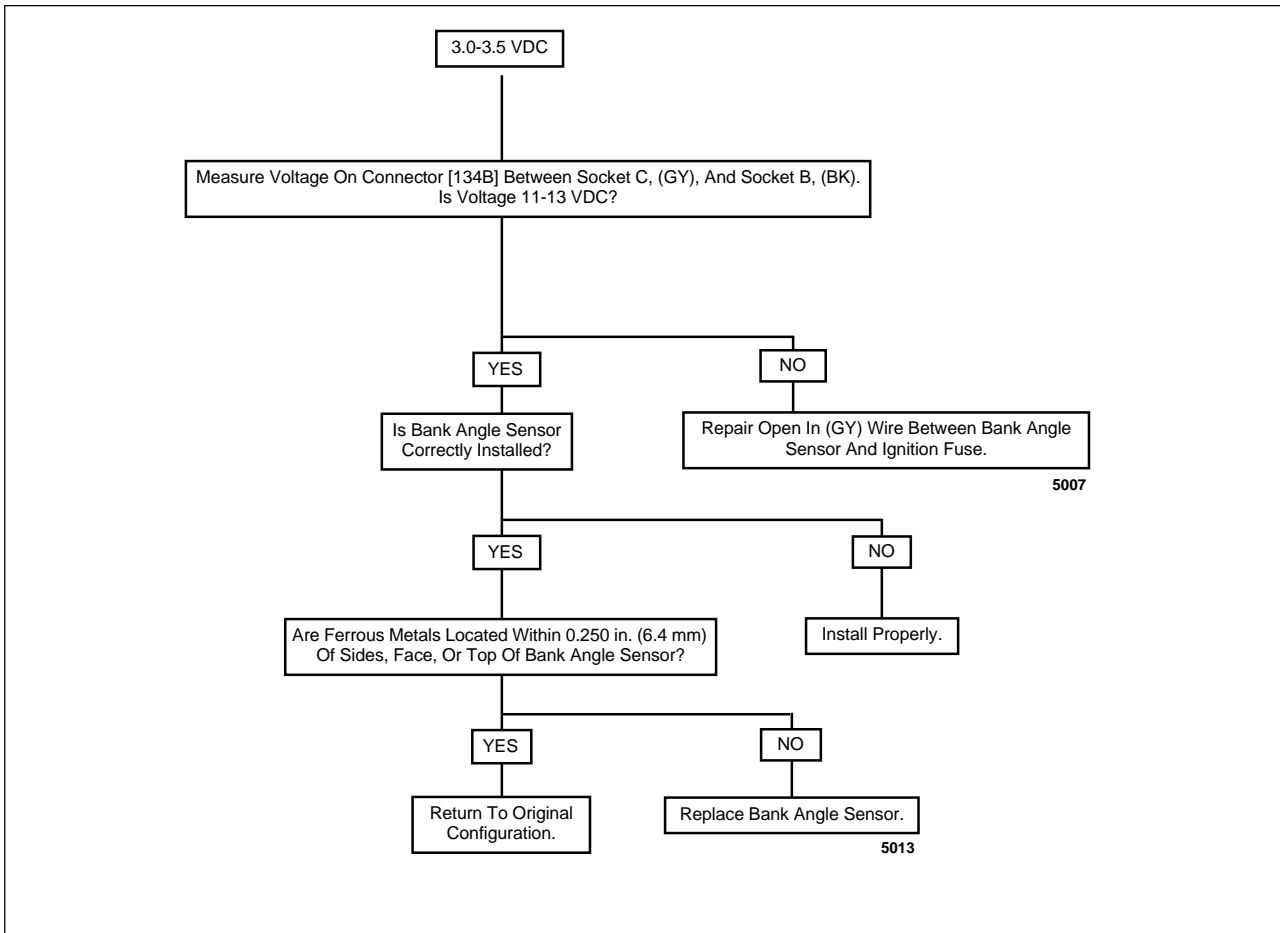


Figure 7-8. Continuous or No Spark At Spark Plug

DRIVABILITY TROUBLESHOOTING

Poor Performance, Poor Fuel Economy, Excessive Pinging

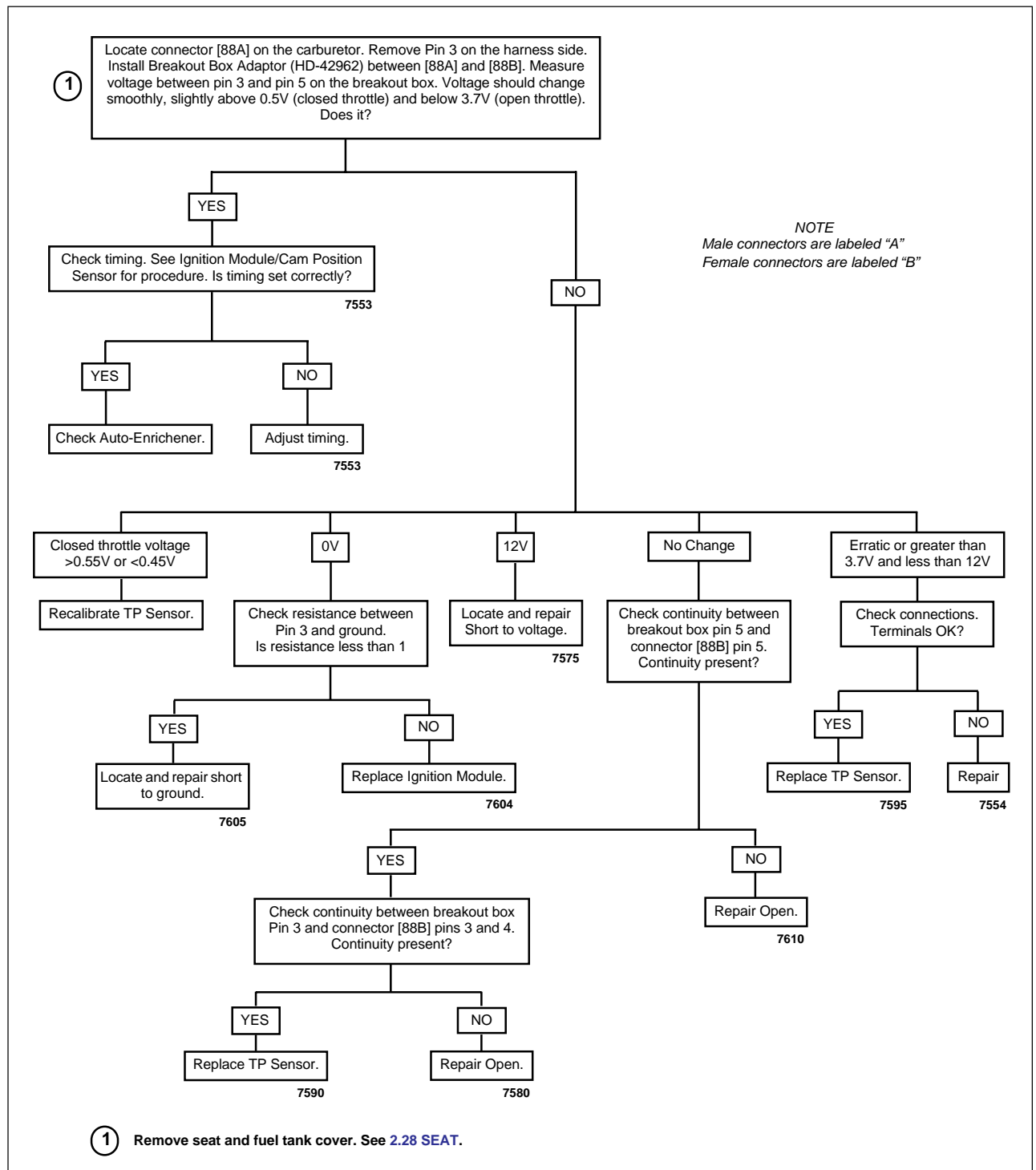


Figure 7-9. Drivability Troubleshooting

GENERAL

See [Figure 7-10](#). The throttle position sensor voltage determines which spark advance curve the ignition module selects. The throttle position sensor (TP Sensor) is located on the carburetor. The TP Sensor is not repairable. Replace the unit if it fails.

See [4.6 THROTTLE POSITION SENSOR](#) for information on replacing the throttle position sensor.

See diagnostic chart on previous page for troubleshooting information.

CALIBRATION/TESTING

NOTE

To gain access to the Throttle Position Sensor, remove the carburetor and air cleaner as an assembly. See [4.4 CARBURETOR](#) and [1.17 AIR CLEANER](#).

1. Adjust throttle position sensor as follows:
 - a. Back off idle adjustment screw so throttle plate is fully closed.
 - b. Completely open and close the throttle by rotating the throttle control through its full range of motion.
 - c. Using special TORX bit (Snap-on® TTXR20E), loosen the two tamper-resistant T20 TORX screws just enough to allow sensor to rotate.
 - d. Separate connector [88] housings and remove socket terminal from chamber 3 in connector [88B] (main wire harness).
 - e. Install BREAKOUT BOX ADAPTORS (Part No. HD-42962) and BREAKOUT BOX (Part No. HD-42682) using black connectors between socket [88B] and pin [88A] housings.
 - f. Turn ignition switch to ON. Using a multimeter, measure voltage between pin 3 (V/W) and pin 5 (BK).
 - g. Adjust (rotate) throttle position sensor (TPS) until voltage reading is 0.5V +/- 0.05V.
 - h. Completely open and close the throttle by rotating the throttle control through its full range of motion. Wide Open Throttle (WOT) should not exceed 3.7V and reading should increase consistently as throttle is opened. If the voltage reading is erratic or the voltage reading at WOT exceeds 3.7V, see [Figure 7-10](#) for diagnostic testing.

NOTE

After WOT, the TPS reading may not return back to exactly 0.5V +/- 0.05V. To re-check exact TPS voltage reading, turn cycle key off and on.

- i. Tighten TP Sensor mounting screws to 13-23 **in-lbs** (2-3 Nm).

2. Install carburetor and air cleaner. See [4.3 AIR CLEANER](#).
3. Adjust idle speed. See [1.19 IGNITION TIMING AND IDLE SPEED ADJUSTMENT](#).

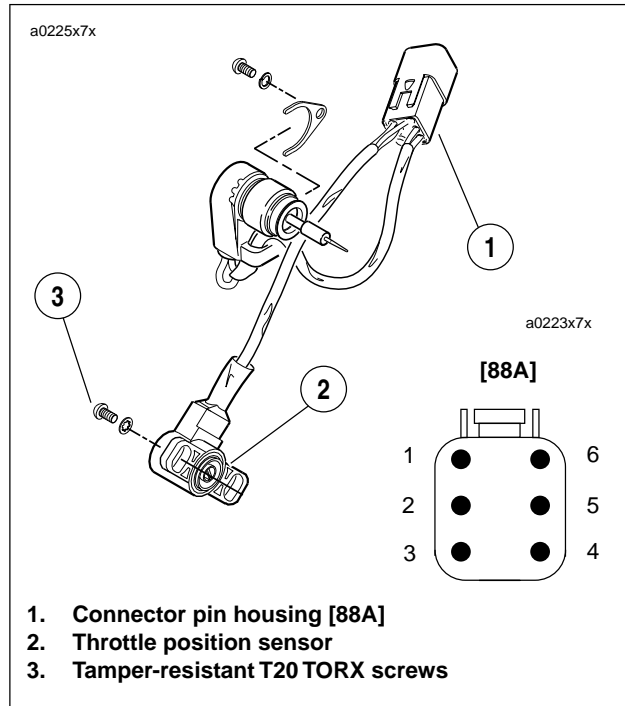


Figure 7-10. Throttle Position Sensor

Table 7-10. Socket Housing [88B]

CHAMBER NUMBER	WIRE COLOR	FUNCTION
1	Violet/Orange	Auto-Enrichener
2	Orange	Auto-Enrichener
3	Violet/White	TP Sensor Output
4	Violet/White	TP Sensor Input
5	Black	TP Sensor Ground
6		Not Used

Table 7-11. Pin Housing [88A]

CHAMBER NUMBER	WIRE COLOR	FUNCTION
1	Yellow	Auto-Enrichener
2	Yellow	Auto-Enrichener
3	Light Blue	TP Sensor Output
4	Yellow	TP Sensor Input
5	Black	TP Sensor Ground
6		Not Used

REMOVAL

1. Remove seat. See 2.28 SEAT.

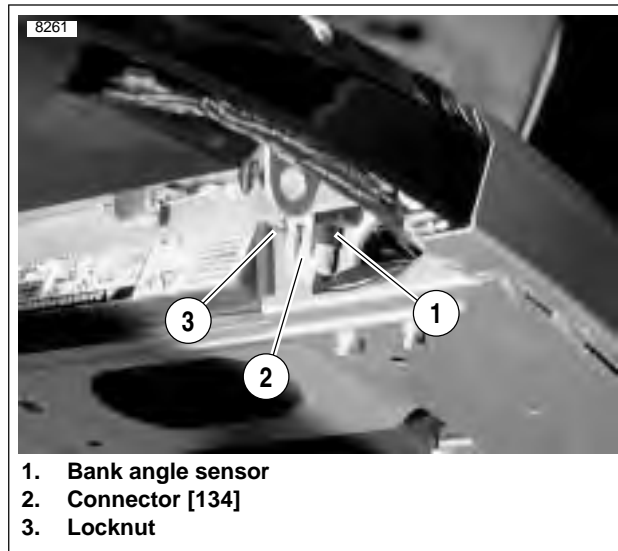
⚠ WARNING

To prevent accidental vehicle start-up, which could cause death or serious injury, disconnect negative (-) battery cable before proceeding. (00048a)

2. Disconnect negative battery cable from battery.

⚠ WARNING

Disconnect negative (-) battery cable first. If positive (+) cable should contact ground with negative (-) cable connected, the resulting sparks can cause a battery explosion, which could result in death or serious injury. (00049a)



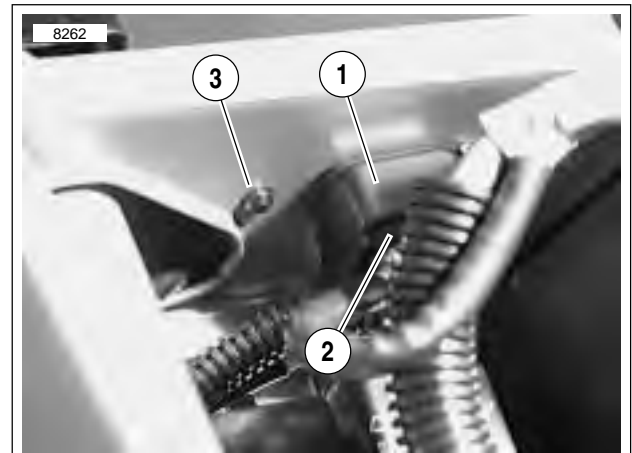
1. Bank angle sensor
2. Connector [134]
3. Locknut

Figure 7-11. Bank Angle Sensor Removal

3. See Figure 7-12. Remove circuit breaker from mounting bracket.
4. Remove allen head screw from mounting bracket while holding locknut on bank angle sensor side.
5. Remove bank angle sensor from its mounting location.
6. Disconnect connector [134] from bank angle sensor.
7. Remove bank angle sensor.

INSTALLATION

1. Connect connector [134] to new bank angle sensor.



1. Circuit breaker bracket
2. Allen screw
3. Locating post

Figure 7-12. Bank Angle Sensor Installation

2. See Figure 7-12. Position bank angle sensor in mounting position on circuit breaker bracket mounting screw. Make sure sensor locating post engages hole in trunk to ensure proper alignment of sensor.
3. Install bank angle sensor with allen screw and locknut. Tighten screw to 25-27 in-lbs (2.8-3.1 Nm).
4. Install circuit breaker to circuit breaker mounting bracket.

⚠ WARNING

Connect positive (+) battery cable first. If positive (+) cable should contact ground with negative (-) cable connected, the resulting sparks can cause a battery explosion, which could result in death or serious injury. (00068a)

5. Install negative battery cable to battery terminal. Tighten fastener to 72-96 in-lbs (8-11 Nm).

⚠ WARNING

After installing seat, pull upward on front of seat to be sure it is in locked position. While riding, a loose seat can shift causing loss of control, which could result in death or serious injury. (00070a)

6. Install seat. See 2.28 SEAT.

GENERAL

WARNING

The automatic-on headlamp feature provides increased visibility of the rider to other motorists. Be sure headlamp is on at all times. Poor visibility of rider to other motorists can result in death or serious injury. (00030b)

See [Figure 7-13](#). The four-position combination ignition/headlamp key switch is not repairable. Replace the unit if it fails.

Switch positions are explained in [Table 7-12](#).

CAUTION

Turn the ignition switch to the OFF position and remove the key before locking the motorcycle. Leaving the key in the PARK position will keep the instrument lights on and result in a discharged battery. (00155a)

NOTE

The key locks the ignition system and is removable in both the OFF, FORK LOCK and P (PARK) positions. The PARK position is located between the OFF and IGNITION positions and allows the rider to remove the key while leaving the lights on. When the key is placed in the PARK position, several indicator markers are or can be activated. Refer to [Table 7-13](#).

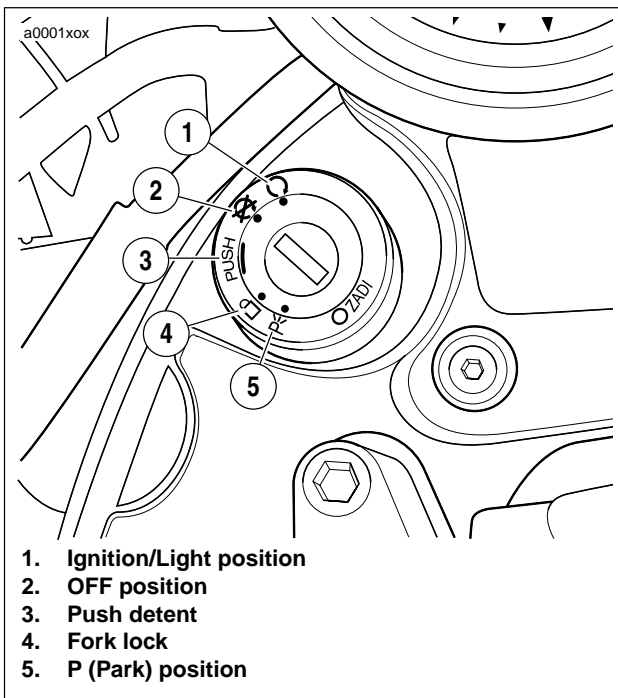


Figure 7-13. Ignition/Headlamp Key Switch

Table 7-12. Ignition Switch Labeling

LABEL	NAME	IGN.	LAMPS	REMOVE KEY
OFF	Off	off	off	yes
LOCK	Fork Lock	off	off	yes
P	Park	off	See note & Table 7-13 .	yes
IGN	Ignition	on		no

Table 7-13. Ignition Switch Operation

ITEM	P	IGN
Headlamp High/Low Beam	off	on
Speedometer Illumination Lamp	on	on
Stop Lamp	can be activated	
Front and Rear Turn Signals	can be activated	
Horn	can be activated	

REMOVAL

1. Remove seat. See 2.28 SEAT.

⚠ WARNING

To prevent accidental vehicle start-up, which could cause death or serious injury, disconnect negative (-) battery cable before proceeding. (00048a)

2. Disconnect negative battery cable from battery terminal.
3. Remove four screws and washers to detach windscreen from mounting brackets. See 2.26 WINDSCREEN.
4. See Figure 7-14. Cut cable tie and disconnect ignition key switch connector [33] from main wiring harness. Note location of cable tie.
5. Remove two headlight bucket bolts and headlamp bucket. See 7.17 HEADLAMP.
6. Remove two bolts and ignition key switch.

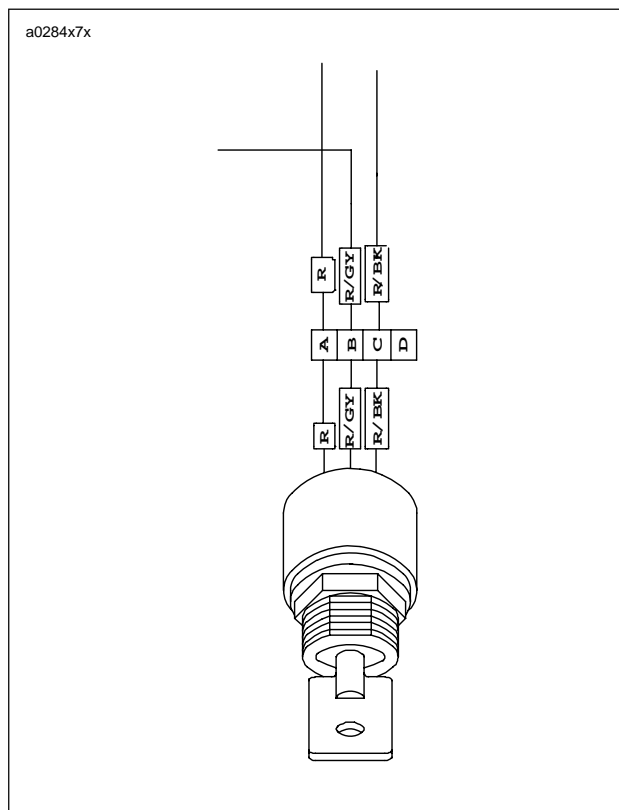


Figure 7-14. Ignition Key Switch Connector [33]

Table 7-14. Ignition Switch Connector [33]

[33] WIRE	TERMINATION
A	Master Circuit Breaker
B	Accessories Fuse in Fuse Block
C	Ignition Fuse in Fuse Block
D	Empty

INSTALLATION

1. Apply Loctite 243 (blue) to threads of two ignition key switch bolts.
2. Install ignition key switch into hole and secure with two bolts. Tighten bolts to 48-72 in-lbs (5-8 Nm).
3. See Figure 7-14. Attach ignition key switch connector [33] to main wiring harness. Secure harness with cable tie.
4. Install headlight bucket with two bolts. Tighten bolts to 12-14 ft-lbs (16-19 Nm).
5. Cable tie ignition key switch connector [33] to main wiring harness.
6. Install four screws and washers to attach windscreen to mounting brackets. See 2.26 WINDSCREEN.
7. Install negative battery cable to battery terminal. Tighten fastener to 72-96 in-lbs (8-11 Nm).

⚠ WARNING

After installing seat, pull upward on front of seat to be sure it is in locked position. While riding, a loose seat can shift causing loss of control, which could result in death or serious injury. (00070a)

8. Install seat. See 2.28 SEAT.

⚠ WARNING

Be sure that all lights and switches operate properly before operating motorcycle. Low visibility of rider can result in death or serious injury. (00316a)

9. Check ignition key switch for proper operation. If operation fails, reread procedure and verify that all steps were performed.
 - a. Turn ignition key switch to OFF. Check all functions listed in Table 7-12.
 - b. Turn ignition key switch to IGN. Start motorcycle. See Section 4.
 - c. Turn ignition key switch to LOCK.

GENERAL

See [Figure 7-15](#). The auto-enrichener controls the cold idle speed of the motorcycle at startup and enriches the air/fuel mixture. It is located on the carburetor. The auto-enrichener is not repairable. Replace the unit if it fails.

NOTE

In extreme cold ambient conditions, auto-enrichener may remain on for longer periods of time.

Normal function of the auto-enrichener is typically 2-5 minute fast idle speed enrichment cycle, even after hot restart. If enrichment cycle exceeds 5 minutes, see diagnostic chart on following page.

See [4.5 AUTO-ENRICHENER](#) for auto-enrichener service procedures.

See diagnostic chart on next page for troubleshooting information.

DIAGNOSTIC NOTES

In the following diagnostic flow chart, the circled number corresponds to the number procedure below.

1. Use black male probe and patch cord from TEST CONNECTOR KIT (Part No. HD-41404).

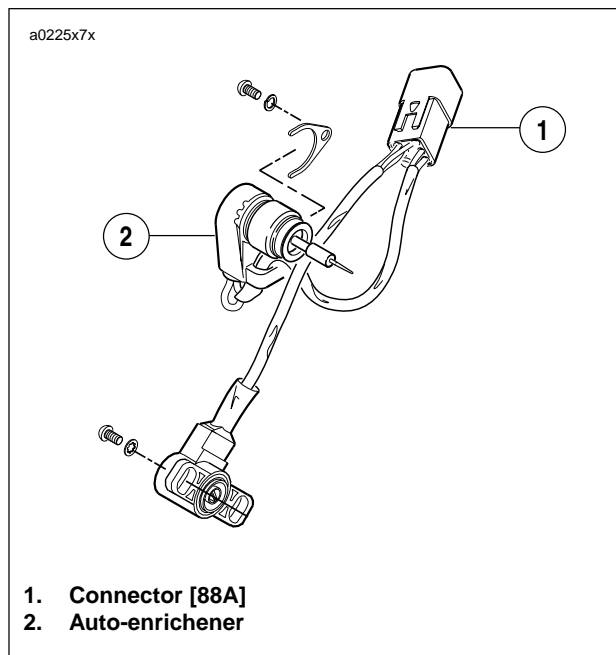


Figure 7-15. Auto-Enrichener

Table 7-15. Socket Housing [88B]

CHAMBER NUMBER	WIRE COLOR	FUNCTION
1	Violet/Orange	Auto-Enrichener
2	Orange	Auto-Enrichener
3	Violet/White	TP Sensor Output
4	Violet/White	TP Sensor Input
5	Black	TP Sensor Ground
6		Not Used

Table 7-16. Pin Housing [88A]

CHAMBER NUMBER	WIRE COLOR	FUNCTION
1	Yellow	Auto-Enrichener
2	Yellow	Auto-Enrichener
3	Light Blue	TP Sensor Output
4	Yellow	TP Sensor Input
5	Black	TP Sensor Ground
6		Not Used

DRIVEABILITY TROUBLESHOOTING

Idle Speed Incorrect

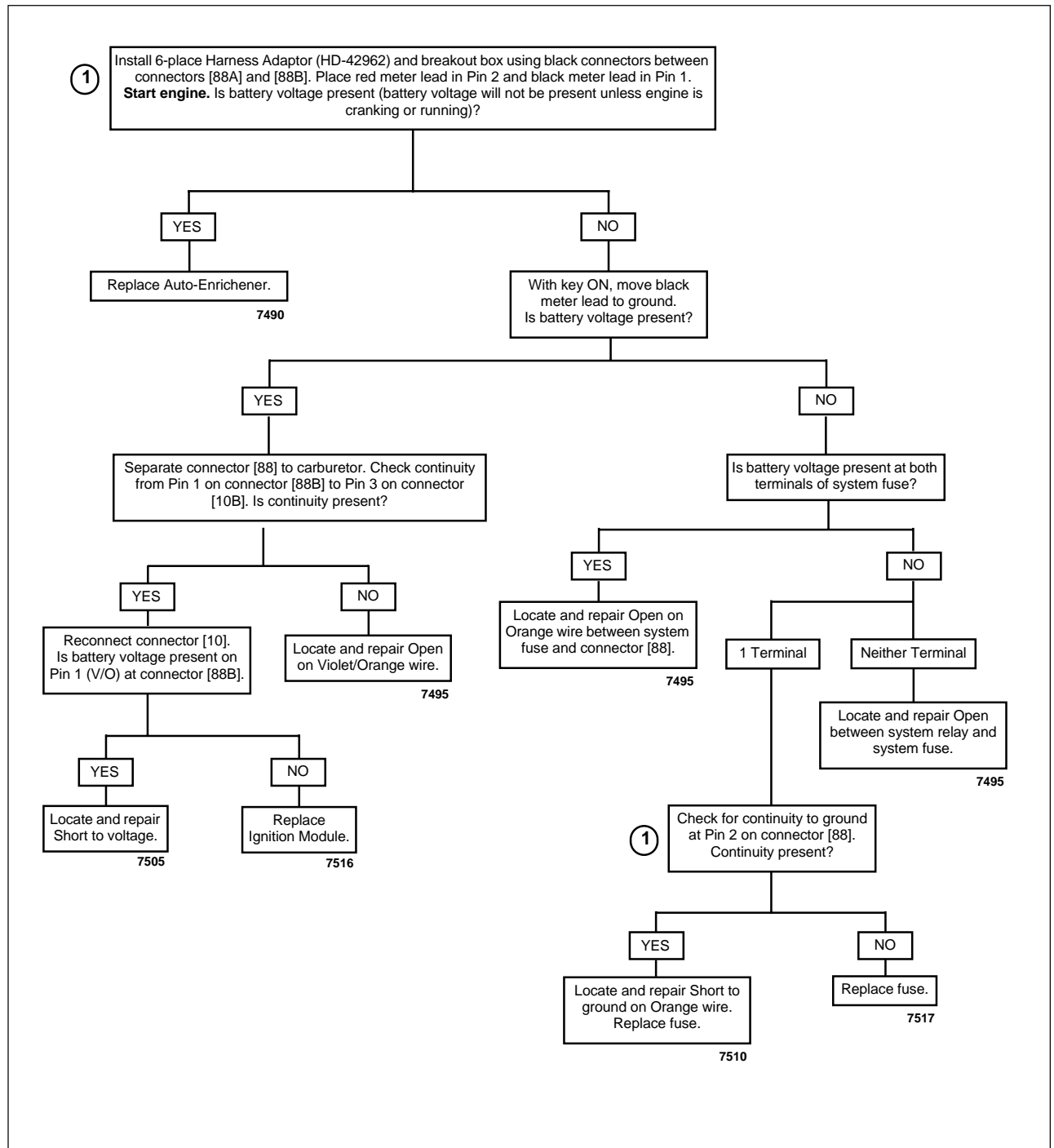


Figure 7-16. Driveability Troubleshooting

GENERAL

See [Figure 7-17](#). The ignition module is integrated with the cam position sensor on the module plate in the gearcase cover located on the right side of the motorcycle. The integrated ignition module is not repairable. Replace the unit if it fails.

For information on the function and testing of the integrated ignition module see [7.2 IGNITION SYSTEM](#).

See [Figure 7-18](#). The rotor cup is located in the gearcase cover on the right side of the vehicle behind the integrated ignition module. The rotor is mounted on the camshaft and operates at one-half crankshaft speed. See [IGNITION TIMING](#) for information on the function, testing and adjustment of the integrated ignition module and trigger rotor assembly.

REMOVAL

1. Remove seat. See [2.28 SEAT](#).

⚠ WARNING

To prevent accidental vehicle start-up, which could cause death or serious injury, disconnect negative (-) battery cable before proceeding. (00048a)

2. Disconnect negative battery cable from battery terminal.
3. Remove locknut and clamp that secures wire harness and hoses on right side of motorcycle.
4. See [Figure 7-17](#). Disconnect connector [10] located on the left side of the frame backbone.
5. Note position of each wiring terminal in plug end of connector.
6. Remove connector terminal pins. See [B.9 DEUTSCH](#).

⚠ WARNING

Always wear proper eye protection when drilling. Flying debris could cause serious eye injury. (00402c)

IMPORTANT NOTES

- **Drilling hole in cover in location other than that specified may result in module plate damage. Drill carefully only where indicated to avoid damaging module plate behind cover.**
 - **Do not pry timer cover from bore or damage to gearcase or ignition module may result.**
7. See [Figure 7-18](#). Drill hole in outer timer cover at 5:00 position approximately 0.500 in. (13 mm) in from outside edge. Pull out outer timer cover using 90 degree pick or other suitable tool.

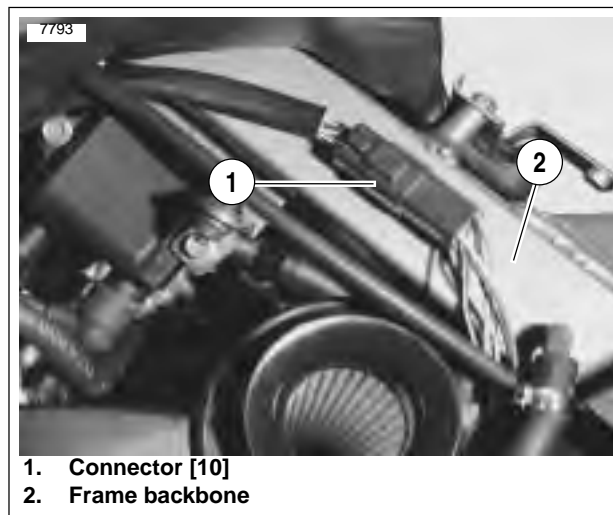


Figure 7-17. Integrated Ignition Module Connector [10]

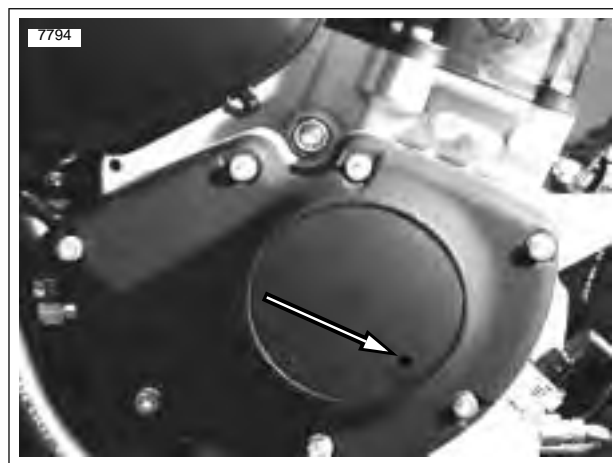
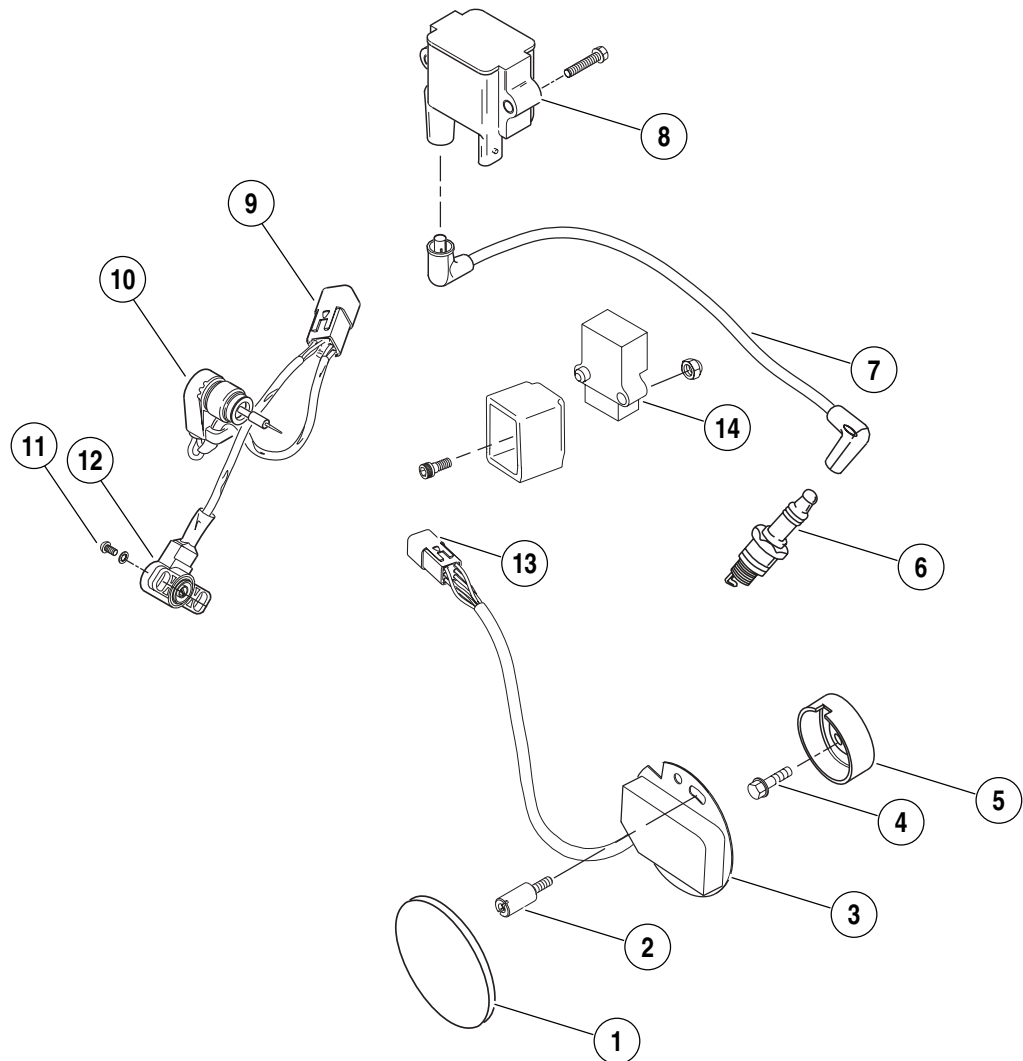


Figure 7-18. Drill Hole Location for Drilling/Removing Timer Cover

8. To obtain approximate ignition timing during installation, scribe alignment marks across module plate and bore in two places.
9. See [Figure 7-19](#). Remove two module plate mounting screws (2). Carefully remove module plate (3). Remove screw (4) and rotor cup (5).
10. Carefully remove camshaft oil seal if damaged or if there is any evidence of oil leakage past the seal.

a0217a7x



1. Timer cover
2. Module plate screws (2)
3. Module plate
(ignition module/cam position sensor)
4. Screw, rotor cup
5. Rotor cup
6. 10r12 spark plug
7. Spark plug cable
8. Ignition coil
9. Connector [88]
10. Auto-enrichener
11. Tamper-resistant T20 TORX screws
12. Throttle position sensor (TP sensor)
13. Connector [10]
14. Bank angle sensor

Figure 7-19. Ignition System Components

INSTALLATION

1. With the lipped side facing inboard, install **new** camshaft oil seal into gearcase cover, if removed. Press seal into position until lightly bottomed.
2. Install rotor cup.
 - a. Apply Loctite 243 (blue) to threads of screw.
 - b. Position rotor cup onto end of camshaft aligning notch with camshaft slot.
 - c. Install screw to secure rotor cup. Tighten screw to 43-53 **in-lbs** (5-6 Nm).
3. Install ignition module/cam position sensor plate with two screws.
4. See [Table 7-17](#). Install ignition module wiring terminals into correct positions in plug end of connector [10]. See Wiring Diagram. Install pin terminals. See [B.9 DEUTSCH](#).
5. See [Figure 7-17](#). Mate connector [10] and install to T-stud on frame backbone.
6. Install locknut to clamp that secures hoses and wire harness on right side of motorcycle.
7. Install module plate with two screws. Do not tighten screws.
8. Install negative battery cable to battery terminal. Tighten fastener to 72-96 **in-lbs** (8-11 Nm).
9. Check ignition timing. See [IGNITION TIMING](#).
10. Tighten module plate screws to 10-20 **in-lbs** (1-2 Nm).
11. Install **new** outer timer cover.

WARNING

After installing seat, pull upward on front of seat to be sure it is in locked position. While riding, a loose seat can shift causing loss of control, which could result in death or serious injury. (00070a)

12. Install seat. See [2.28 SEAT](#).

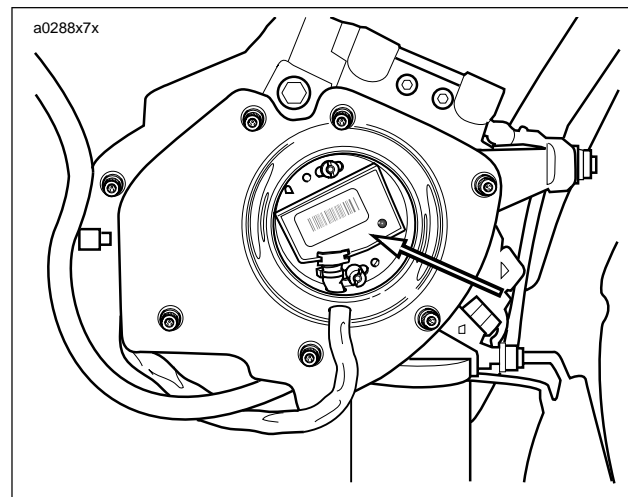


Figure 7-20. Ignition Module and Cam Position Sensor

Table 7-17. Ignition Module Connector [10]

CHAMBER NUMBER	WIRE COLOR	FUNCTION
1	White/Black	To Ignition Switch
2	Violet/White	To TP Sensor
3	Violet/Orange	To Auto-Enrichener
4	Pink	To Coil
5	*Lt Green/Grey [10A] *Tan/Yellow [10B]	To Sidestand Interlock
6	Black	Ground

IGNITION TIMING

NOTE

Use static timing method if inductive timing light is not available.

Dynamic Timing

1. Remove hex socket timing plug from timing inspection hole, which is located on right crankcase half and centered below engine cylinders. Install TIMING MARK VIEW PLUG (Part No. HD-96295-65D) into timing inspection hole. Make sure view plug does not touch flywheel.
2. Connect leads of INDUCTIVE TIMING LIGHT (Part No. HD-33813) to spark plug cable, battery positive (+) terminal, and suitable ground.
3. Make sure vacuum hose is properly installed at carburetor. Start engine.
4. Make sure sidestand is up and transmission is in NEUTRAL.
5. Set engine speed to 1200 RPM.

IMPORTANT NOTE

When checking ignition timing, always check at the RPM listed. Failure to do so may result in running engine with too much spark advance, and may cause extreme engine knock and engine failure.

6. See [Figure 7-21](#). Timing light will flash each time an ignition system spark occurs. Aim timing light into timing inspection hole. The advance timing mark (two dots) should be centered in timing inspection hole.
 - a. If this is the case, ignition timing is properly adjusted. Go to Step 11.
 - b. If timing mark is not centered or is not visible in the timing inspection hole, see to Steps 7-12.
7. See [Figure 7-18](#). Drill hole in location shown and remove outer timer cover, if not removed.
8. Loosen module plate screws just enough to allow sensor plate to be rotated using a screwdriver in the plate's notch.
9. See [Figure 7-21](#). With timing light aimed into inspection hole, rotate module plate until advance timing mark is centered in timing inspection hole.
10. See [Figure 7-18](#). Tighten module plate screws to 10-20 **in-lbs** (1-2 Nm).
11. Install **new** outer cover, if removed.
12. Remove TIMING MARK VIEW PLUG from timing inspection hole. Install hex socket timing plug. Tighten timing plug to 10-15 ft-lbs (14-20 Nm).

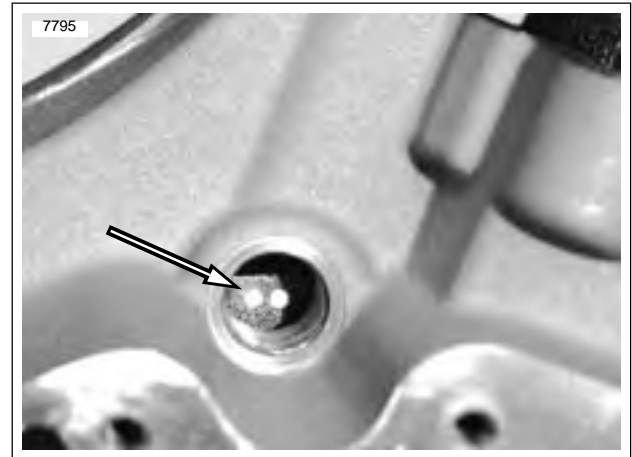


Figure 7-21. Advance Mark for Dynamic Ignition Timing

Static Timing

NOTE

The outer timer cover is tamper-resistant and must be drilled out. A **new** outer timer cover will be required when doing this procedure. Do not reuse timer cover after hole has been drilled in it.

1. See Figure 7-22. Locate outer timer cover on the gear-case cover on the right side of vehicle.

WARNING

Always wear proper eye protection when drilling. Flying debris could cause serious eye injury. (00402c)

2. See Figure 7-22. Drill hole in outer timer cover at 5:00 position approximately 0.500 in. (13 mm) in from edge. Pull out outer timer cover using 90 degree pick or other suitable tool.
3. Remove the timing plug from the timing inspection hole centered below the cylinder on the right side of the crankcase.
4. Remove the spark plug.
5. Jack up or hoist vehicle to allow rotation of the rear wheel.

NOTE

To check for intake valve closing place a finger over the spark plug hole opening. While engine is on compression stroke, air will be expelled from hole. When air is no longer expelled from hole, both valves are closed and engine should be close to TDC and between compression and power stroke.

6. Shift transmission into fifth gear, and standing on **left** side of vehicle, slowly rotate rear wheel in direction of forward motion (counter-clockwise) until front intake valve opens and closes.
7. See Figure 7-22. Rotate rear wheel from **right** side of vehicle in direction of forward motion (clockwise) until TDC mark (vertical line) is centered in timing inspection hole.
8. Turn ignition switch to ON position, make sure sidestand is up and place transmission in NEUTRAL.
9. See Figure 7-23. Loosen two screws and slowly rotate module plate until red LED illuminates. Tighten module plate screws to 10-20 **in-lbs** (1-2 Nm) when complete.
10. Install **new** outer cover.
11. Install timing plug. Tighten plug to 10-15 ft-lbs (14-20 Nm).
12. If possible, dynamically time engine as well to verify that system is functioning properly. See DYNAMIC TIMING. Begin at Step 2.

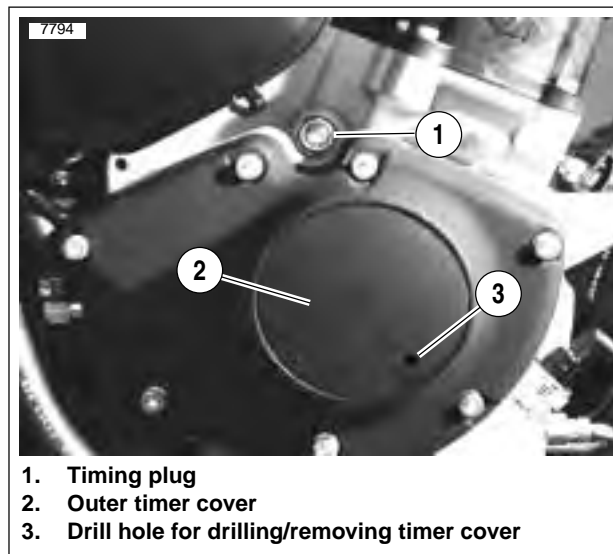


Figure 7-22. Timer Cover and Inspection Hole

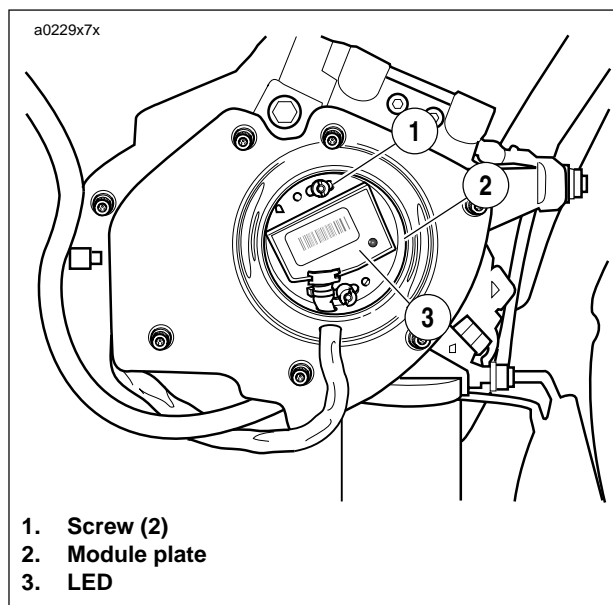


Figure 7-23. Static Ignition Timing (Typical)

GENERAL

See [Figure 7-24](#). The ignition coil is mounted on the frame underneath the fuel tank on left side above airbox.

The ignition coil is a pulse-type transformer. Internally, the coil consists of primary and secondary windings with a laminated iron core. The contents are sealed in a waterproof insulating compound. The ignition coil is not repairable. Replace the unit if it fails.

The low-voltage ignition primary circuit consists of the coil primary winding, ignition module and battery. When the circuit is closed, current flows through the coil primary winding creating a strong magnetic field in the iron core of the ignition coil.

When the ignition module receives a signal from the cam position sensor and trigger rotor, the ignition module interrupts (opens) the ignition primary circuit, which causes the magnetic field in the coil core to collapse.

The collapsing magnetic field induces a high-voltage electrical discharge in the ignition secondary circuit, which consists of the coil secondary winding, spark plug cable and spark plug. The high-voltage discharge produces a spark to bridge the electrode gap of the spark plug.

The ignition coil fires the spark plug at the end of the compression stroke (no-waste spark).

TROUBLESHOOTING

Follow the troubleshooting procedures listed under [7.8 IGNITION MODULE AND CAM POSITION SENSOR](#) if the engine will not start, is difficult to start or runs roughly. Also check condition of the spark plug cable. Insulation on cable may be cracked or damaged allowing high tension current to short to metal parts. This problem is most noticeable when cable is wet.

If poor starting/running condition persists, check resistance of ignition coil primary and secondary winding using an ohmmeter.

Ignition Coil Primary Circuit Test

1. Remove ignition coil.
2. Set ohmmeter scale to RX1.
3. See [Figure 7-25](#). Using gray female probes and patch cord from TEST CONNECTOR KIT (Part No. HD-41404), place multimeter wires on primary coil windings. See [7.3 DIAGNOSTIC CHARTS](#).
4. Check for primary coil winding resistance.
 - a. Normal resistance range is 0.4-0.6 ohms.
 - b. See [TEST RESULTS](#) on the next page if resistance is not within normal operating range.

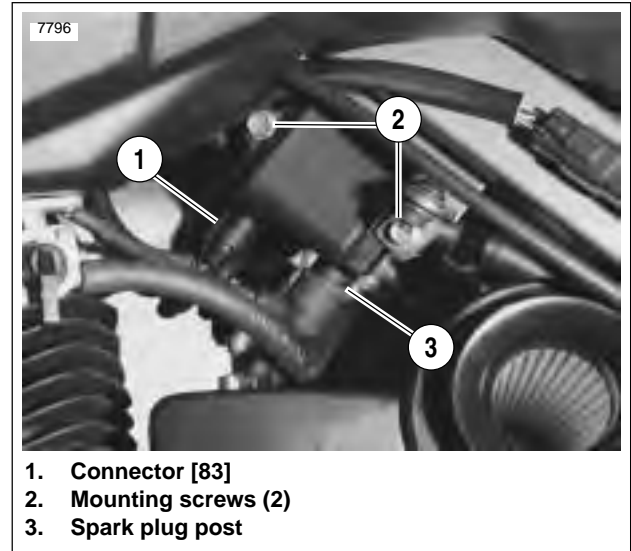


Figure 7-24. Ignition Coil (Left Side)



Figure 7-25. Ignition Coil Primary Resistance Test

Ignition Coil Secondary Circuit Test

1. Remove ignition coil.
2. Set ohmmeter scale to RX1K.
3. See [Figure 7-26](#). Using gray female probes and patch cord from TEST CONNECTOR KIT (Part No. HD-41404), place multimeter wires on secondary coil windings. See [7.9 IGNITION COIL](#).
4. Check for secondary coil winding resistance.
 - a. Normal resistance range is 7720-9440 ohms.
 - b. See [Test Results](#) if resistance is not within normal operating range.

Test Results

1. A low resistance value indicates a short in the coil winding. Replace coil.
2. A high resistance value might indicate that there is some corrosion/oxidation of the coil terminals. Clean the terminals and repeat resistance test. If resistance is still high after cleaning terminals, replace coil.
3. An infinite ohms (∞ or no continuity) resistance value indicates an open circuit (a break in the coil winding). Replace coil.

REMOVAL

1. Remove seat. See [2.28 SEAT](#).

WARNING

To prevent accidental vehicle start-up, which could cause death or serious injury, disconnect negative (-) battery cable before proceeding. (00048a)

2. Disconnect negative battery cable from battery terminal.
3. Remove fuel tank cover. See [4.2 FUEL TANK COVER/ FUEL TANK](#).
4. Remove left side cover.
5. See [Figure 7-24](#). Disconnect spark plug cable from coil plug post.
6. See [Figure 7-27](#). Disconnect coil connector [83].
7. Remove two screws and washers and coil.

INSTALLATION

1. See [Figure 7-24](#). Apply Loctite 243 (blue) to threads of two mounting screws.
2. Attach coil to frame with screws and washers (1). Tighten to 48-72 **in-lbs** (5-8 Nm).
3. Attach coil connector [83].
4. Connect spark plug cable to ignition coil.
5. Attach left side cover.
6. Install negative battery cable to battery terminal. Tighten fastener to 72-96 **in-lbs** (8-11 Nm).
7. Install fuel tank cover. See [4.2 FUEL TANK COVER/ FUEL TANK](#).

WARNING

After installing seat, pull upward on front of seat to be sure it is in locked position. While riding, a loose seat can shift causing loss of control, which could result in death or serious injury. (00070a)

8. Install seat. See [2.28 SEAT](#).



Figure 7-26. Ignition Coil Secondary Resistance Test at Terminal C

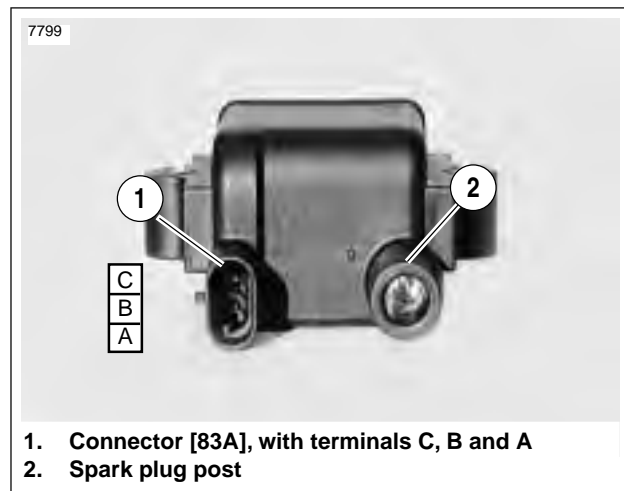


Figure 7-27. Coil Viewed From Bottom

Table 7-18. Coil Connector [83]

CHAMBER NUMBER	WIRE COLOR	FUNCTION
A	White/Black	(+) To Right Handlebar Switch
B	Pink	(-) To Ignition Module
C	Black	Ground

GENERAL

Resistor-type high-tension spark plug cables have a carbon-impregnated fabric core, instead of solid wire, for radio noise suppression and improved reliability of electronic components. Use the exact replacement cable for best results.

REMOVAL

⚠ WARNING

Never disconnect the spark plug cable with the engine running. If you disconnect the spark plug cable with the engine running, you may receive a severe electric shock from the ignition system which could result in death or serious injury.

IMPORTANT NOTE

When disconnecting the spark plug cable from its spark plug terminal, always grasp and pull on the rubber boot at the end of the cable assembly (as close as possible to the spark plug terminal). Do not pull on the cable portion itself. Pulling on the cable will damage the cable's carbon core.

Disconnect spark plug cable from ignition coil and spark plug terminal. Inspect removed cable for damage.

INSPECTION

1. See [Figure 7-28](#). Inspect spark plug cable. Replace cable if worn or damaged.
 - a. Check for cracks or loose terminals.
 - b. Check for loose fit on ignition coil and spark plug.
2. Check cable boot/cap for cracks or tears. Replace boot/cap if worn or damaged.
3. See [Figure 7-29](#). Check spark plug cable resistance with an ohmmeter. Replace cables not meeting resistance specifications of 2375-5833 ohms.

INSTALLATION

1. Connect spark plug cable to ignition coil and spark plug.
2. Fasten boot/cap securely. Tight connections provide the necessary moisture-proof environment for the ignition coil and spark plug terminals.

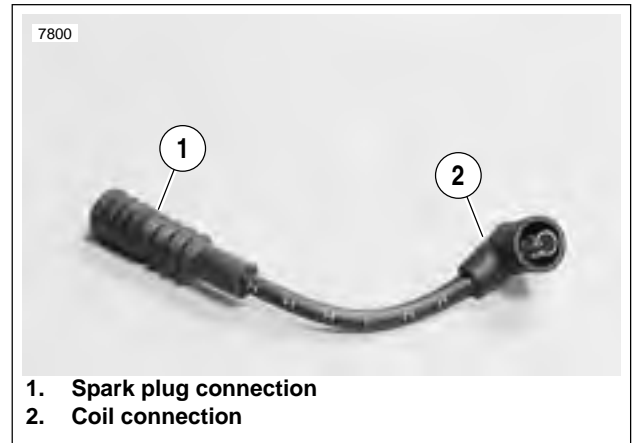


Figure 7-28. Spark Plug Cable (Typical)

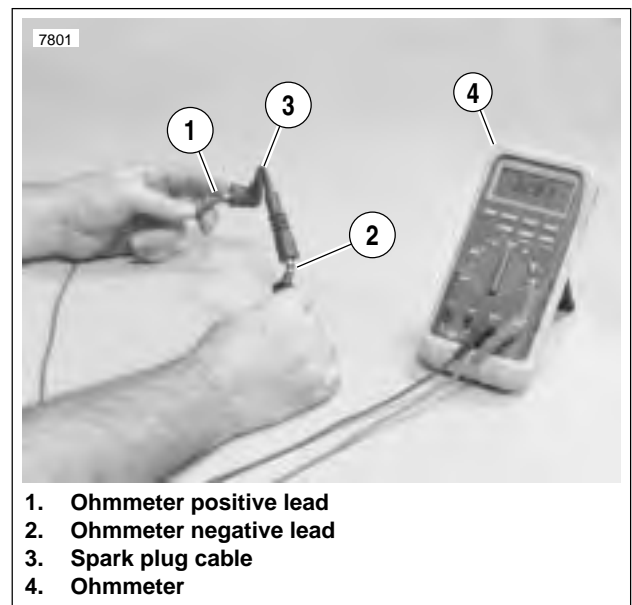


Figure 7-29. Testing Resistance

GENERAL

The starter/ignition interlock system is designed to prevent unintended start-up and/or forward motion of the motorcycle. One of three conditions must exist to allow operation of the vehicle:

- Clutch disengaged (lever pulled in)
- Transmission in Neutral
- Sidestand retracted

Table 7-19. Voltage At TN/Y Wire At Connector [10B]

CONDITION	SIDESTAND DOWN	SIDESTAND UP
Clutch Engaged Transmission in Gear	<1.0V	12V (Battery Voltage)
Neutral	Battery Voltage minus 0.7V +/- 0.1V	12V (Battery Voltage)
Clutch Disengaged	Battery Voltage minus 0.7V +/- 0.1V	12V (Battery Voltage)

Starter Circuit

The starter circuit prevents the motorcycle from being started unless a ground has been established at the starter relay. This ground comes from one source.

- By disengaging the clutch (pulling in the clutch lever) and grounding through the clutch lever switch.

Once the starter circuit is grounded and the starter button pushed, the starter relay can be energized. The energized relay then allows the starter motor to crank the engine.

Ignition Circuit

The ignition circuit prevents the motorcycle from operating unless a ground is established at the system relay. If this ground is not established, the ignition system will not be turned on and the motorcycle will not run. Grounds may be established three ways.

- By retracting the sidestand and grounding through the **sidestand switch**. See Ignition Test 1 on following page to check sidestand switch function.
- By placing the motorcycle in neutral and grounding through the **neutral switch**. See Ignition Test 2 on following page to check neutral switch function.
- By disengaging the clutch and grounding through the **clutch lever switch**. See Ignition Test 3 on page 7-28 to check clutch switch function.

Note that the ignition circuit is enabled when the transmission is in gear with the sidestand extended if the clutch is disengaged (clutch lever pulled in). However, if the motorcycle is in gear with the sidestand extended, and the clutch lever is released, the ignition ground is lost and the ignition system is turned off. This system will prevent vehicle operation if forward motion is attempted with the sidestand down.

See [7.3 DIAGNOSTIC CHARTS](#) for Ignition Tests.

DIAGNOSTIC NOTES

In the following diagnostic flow charts, the circled numbers correspond to the diode tests found in the [TESTING/REPLACEMENT](#) section following the **Starter/Ignition Interlock System** wiring diagram.

Use gray male probe and patch cord from TEST CONNECTOR KIT (Part No. HD-41404) to perform the tests.

DIAGNOSTICS

Ignition Test 1 - Sidestand Switch Function

CONDITION: Sidestand up and key ON, transmission in neutral and clutch engaged

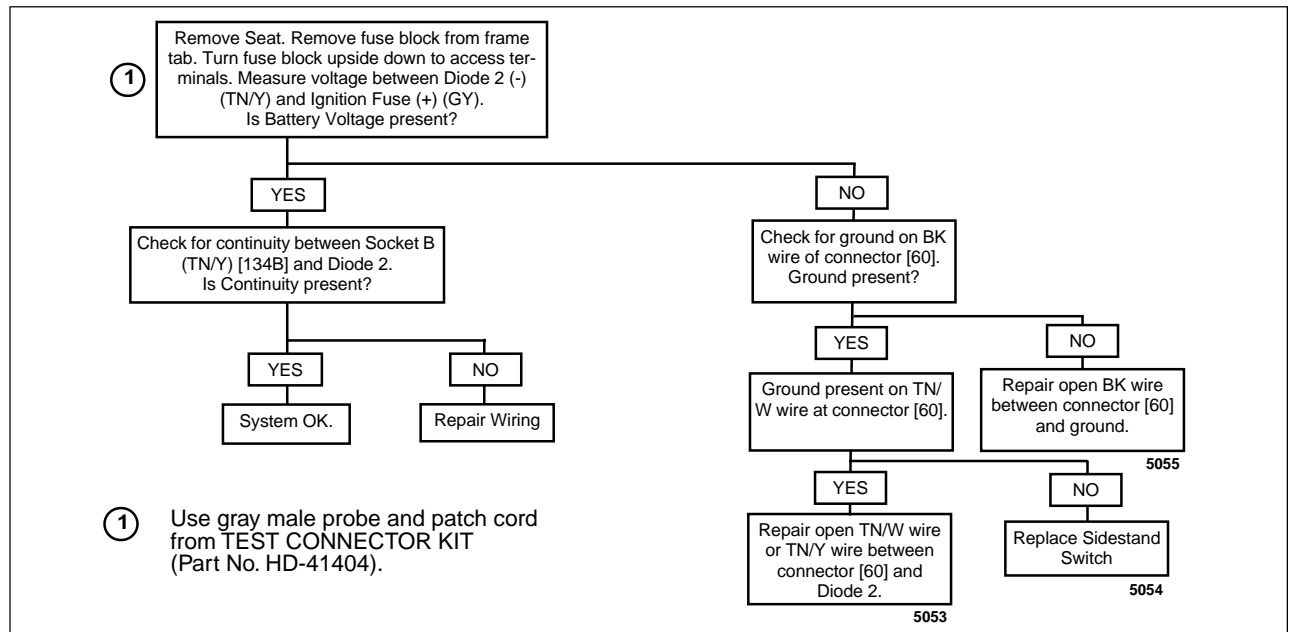


Figure 7-30. Ignition Test 1

Ignition Test 2 - Neutral Switch Function

CONDITION: Sidestand down, key ON, transmission in neutral and clutch engaged

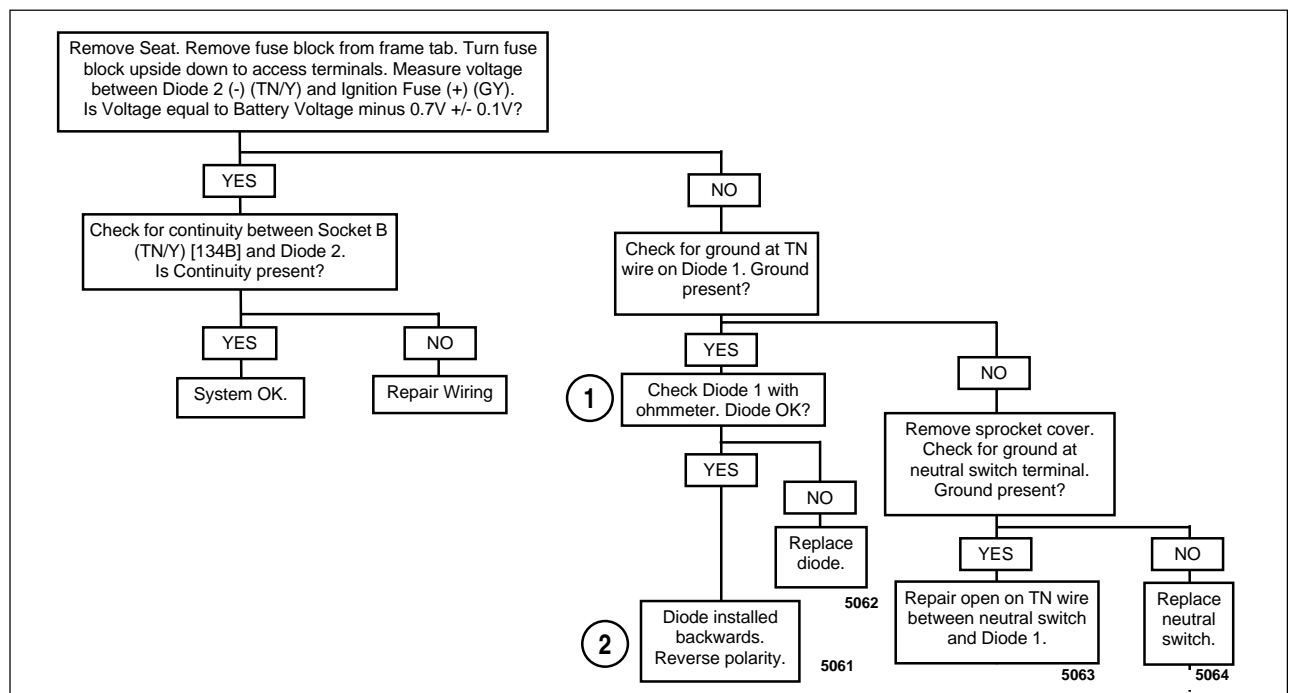


Figure 7-31. Ignition Test 2

Ignition Test 3 - Clutch Switch Function

CONDITION: Sidestand down, key ON, transmission in gear and clutch disengaged

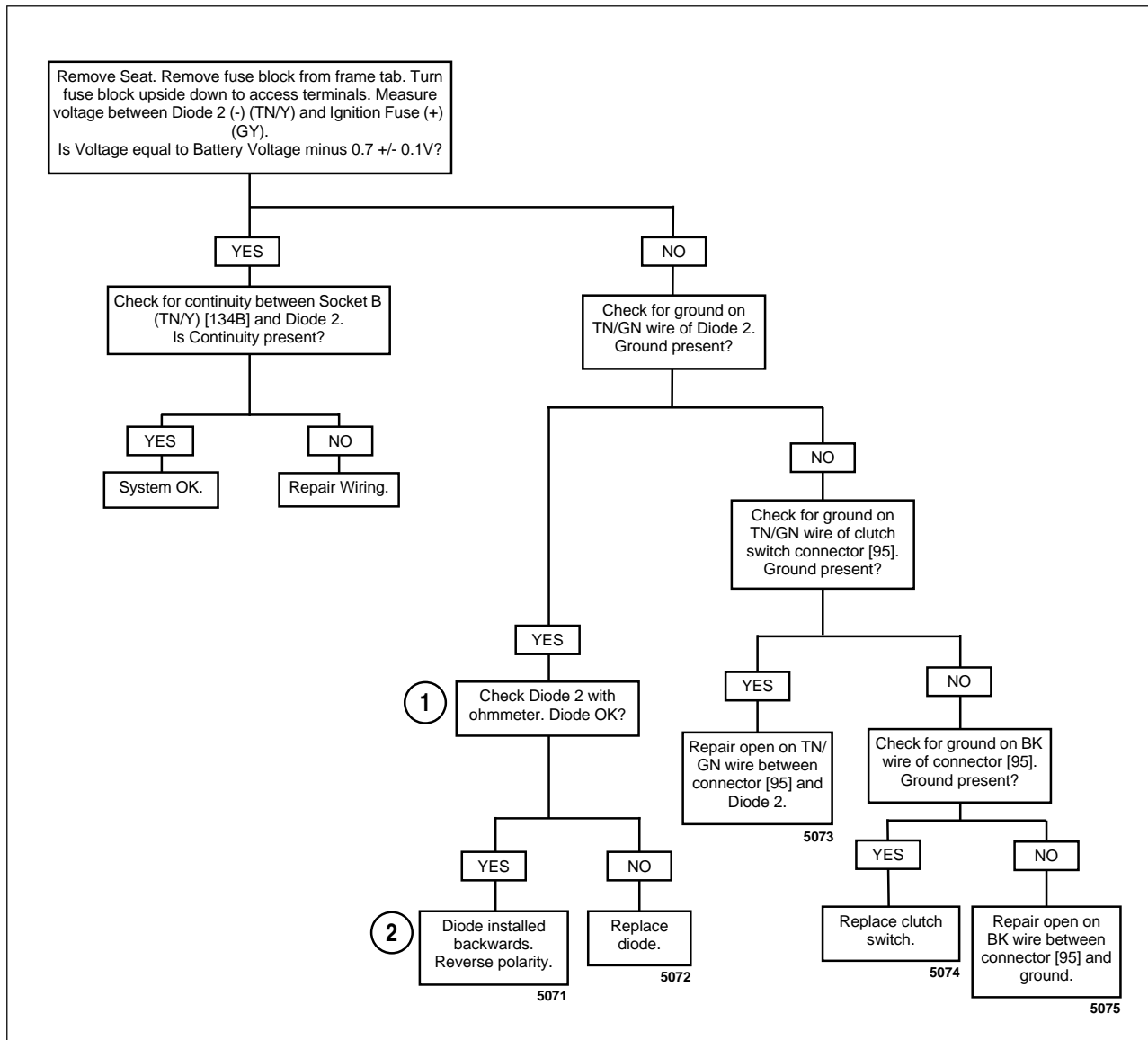


Figure 7-32. Ignition Test 3

a0194x5x

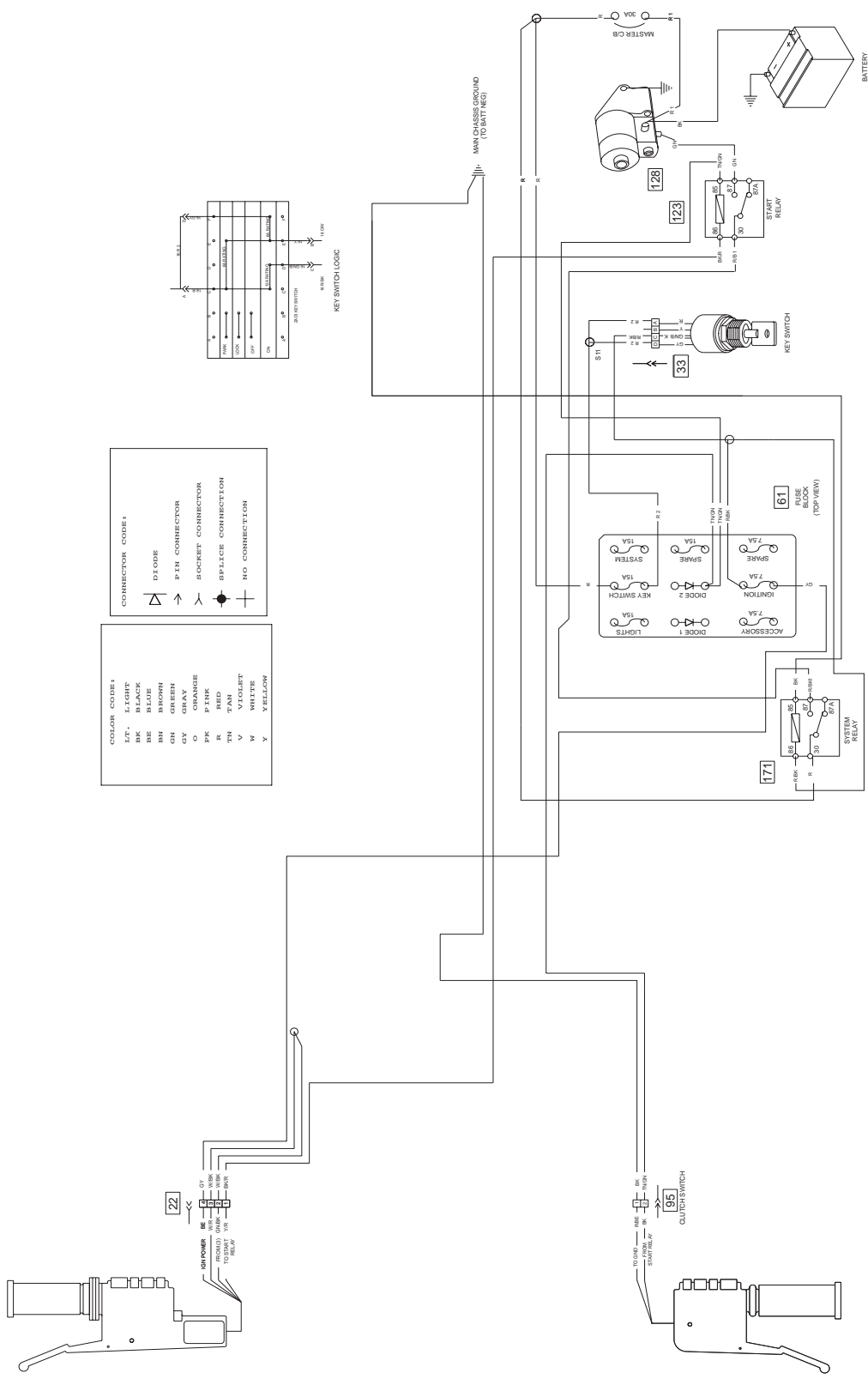


Figure 7-33. Starter/Ignition Interlock System

TESTING/REPLACEMENT

Sidestand Switch

See [Figure 7-34](#). The sidestand switch is a simple spring loaded plunger. The switch completes a path to ground for the ignition relay when the sidestand is in the retracted position.

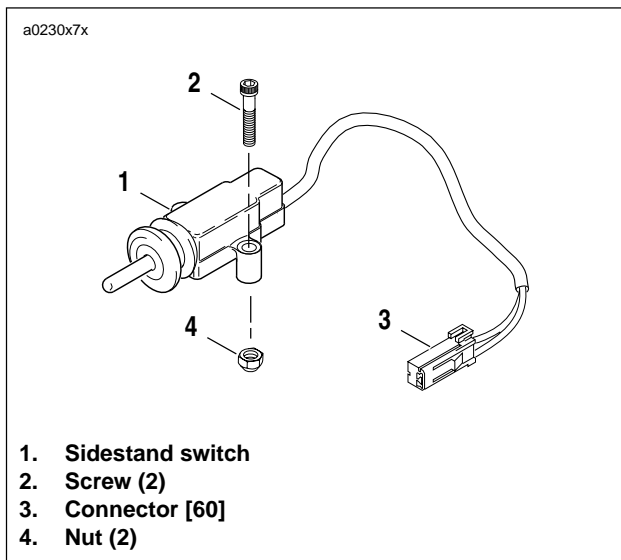


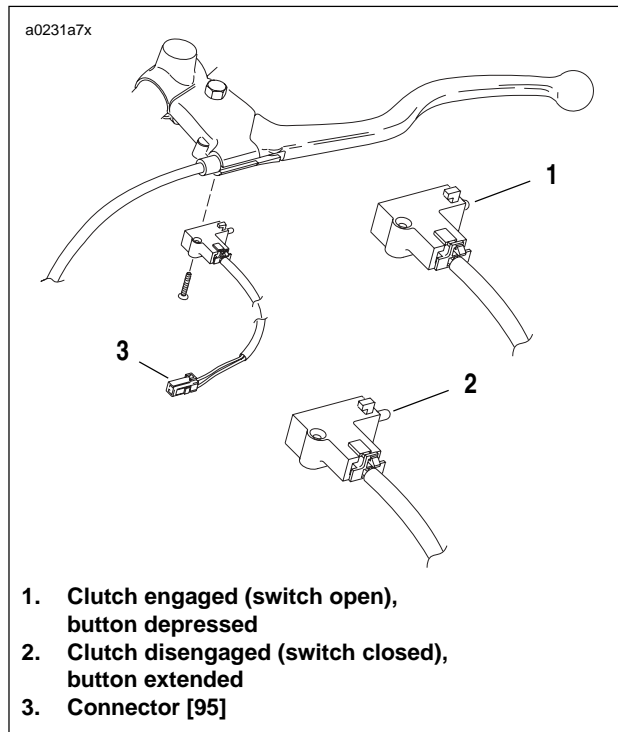
Figure 7-34. Sidestand Switch

Test the switch as follows:

1. Unplug the 2-place sidestand switch connector [60].
2. Test the switch using an ohmmeter.
 - a. With sidestand down (switch open), the switch should show ∞ ohms (infinite ohms).
 - b. With sidestand up (switch closed), the switch should show 0 ohms or little resistance.
3. Replace the assembly with a **new** switch if necessary.
 - a. Remove sidestand switch from Sidestand by removing two bolts and nuts.
 - b. Apply Loctite 243 (blue) to threads of two bolts.
 - c. Install **new** sidestand switch with two bolts and nuts. Tighten bolts to 30-36 **in-lbs** (3-4 Nm).

Clutch Switch

See [Figure 7-35](#). The clutch switch attaches to the clutch control lever bracket. The switch completes a path to ground for the ignition relay and the starter relay when the clutch is disengaged.



1. Clutch engaged (switch open), button depressed
2. Clutch disengaged (switch closed), button extended
3. Connector [95]

Figure 7-35. Clutch Switch

Test the switch as follows:

1. Unplug the 2-place clutch switch connector [95].
2. Test the switch using an ohmmeter.
 - a. With clutch engaged (1) (switch open), the switch should show ∞ ohms (infinite ohms).
 - b. With clutch disengaged (2) (switch closed), the switch should show 0 ohms or little resistance.
3. Replace the assembly with a **new** switch if necessary.
 - a. Remove small Phillips screw.
 - b. Depress clutch lever and hold.
 - c. Detach switch by depressing switch trigger button and pulling switch towards the end of the handlebar.
 - d. Install **new** switch.

NOTE

To test/replace the neutral switch, see [7.23 NEUTRAL INDICATOR SWITCH](#).

System Relay

See [Figure 7-36](#). The system relay is in the relay block which is located on the left side under the seat. Test the relay as follows:

1. Remove seat. See [2.28 SEAT](#).
2. Unplug relay from connector. Test the relay in the same fashion as the starter relay. See [5.6 STARTER SYSTEM TESTING](#).
3. Replace the relay with a **new** relay if necessary. Install relay to frame with new rivet and washer.

Starter Relay

The starter relay is located on the right side of the motorcycle, underneath the seat by the flasher relay.

Main Circuit Breaker

See [Figure 7-37](#). Attached to the frame above the battery, the main circuit breaker is between the ignition key switch and the battery. Remove the main circuit breaker as follows:

1. Remove seat. See [2.28 SEAT](#).

⚠ WARNING

To prevent accidental vehicle start-up, which could cause death or serious injury, disconnect negative (-) battery cable before proceeding. (00048a)

2. Disconnect battery negative cable from battery.
3. See [Figure 7-38](#). Remove acorn nuts, nuts with lock washers and wire leads from circuit breaker studs. Tag wire leads for ease of assembly.
4. See [Figure 7-37](#). Remove circuit breaker from circuit breaker bracket by carefully prying tab, located on left side, open and sliding circuit breaker out.

NOTE:

Bank Angle Sensor will require reinstallation if bracket is removed. See [7.5 BANK ANGLE SENSOR](#).

5. Install in the reverse order. Tighten screw (if bracket was removed) to 25-27 **in-lbs** (2.8-3.1 Nm). Tighten metal nut to 15-18 **in-lbs** (1.7-2 Nm). Tighten plastic acorn nuts to 1-3 **in-lbs** (0.1-0.3 Nm).
6. Connect negative battery cable to battery terminal. Tighten fastener to 72-96 **in-lbs** (8-11 Nm).

⚠ WARNING

After installing seat, pull upward on front of seat to be sure it is in locked position. While riding, a loose seat can shift causing loss of control, which could result in death or serious injury. (00070a)

7. Install seat. See [2.28 SEAT](#).



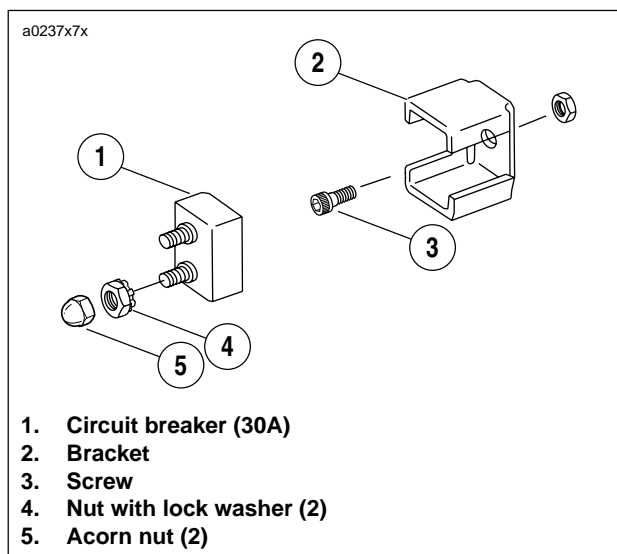
1. System relay
2. Connector [171]

Figure 7-36. System Relay



1. Bracket
2. Tab
3. Circuit breaker (30A)

Figure 7-37. Circuit Breaker



1. Circuit breaker (30A)
2. Bracket
3. Screw
4. Nut with lock washer (2)
5. Acorn nut (2)

Figure 7-38. Circuit Breaker Installation

Ignition Fuse

See [Figure 7-39](#). The ignition fuse (5) is in the fuse block under the seat. Always replace the ignition fuse with a 7.5 ampere fuse.

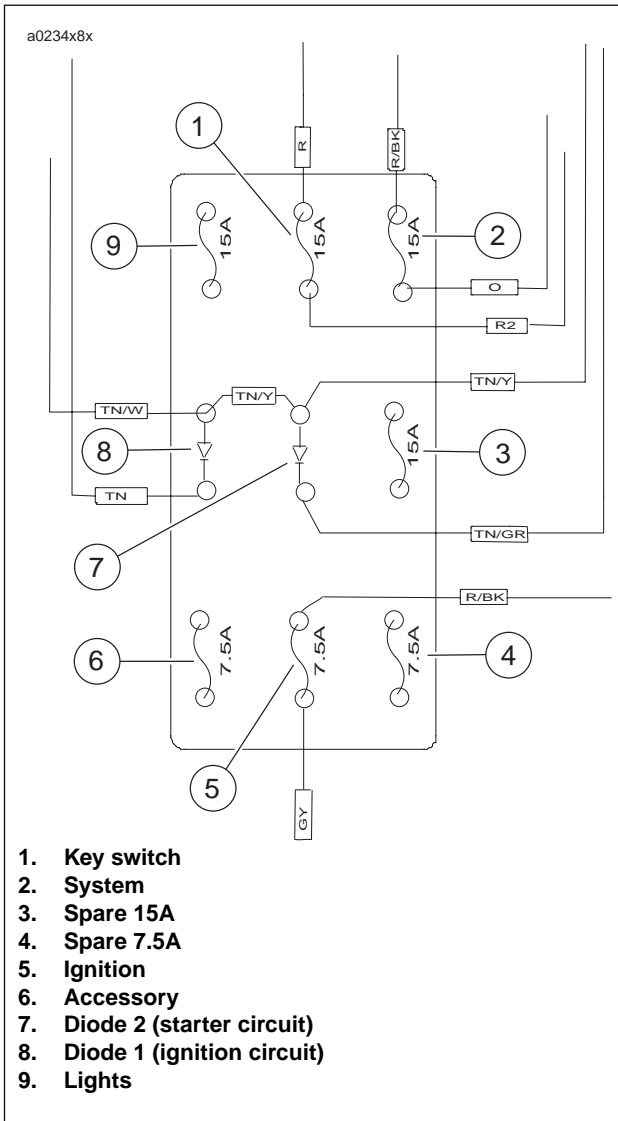


Figure 7-39. Fuse Block [61]

Diodes

See [Figure 7-39](#). The fuse block contains two diodes, diode 2 (7) for the starter circuit and diode 1 (8) for the ignition circuit. A diode acts as a one way switch which permits current flow in one direction, but not in the other.

The circled numbers in the [7.11 STARTER/IGNITION INTER-LOCK](#) diagnostic ignition test flow charts correspond to the following tests.

1. Check diode with an ohmmeter as shown in [Figure 7-40](#).
2. Check diode polarity as shown in [Figure 7-41](#).

Replace diodes as necessary.

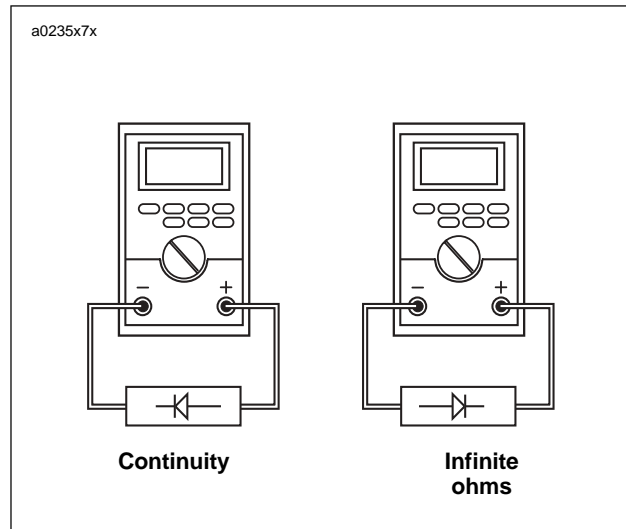


Figure 7-40. Ohmmeter Diode Test

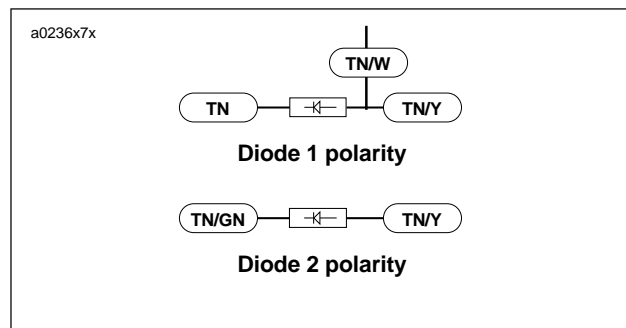


Figure 7-41. Diode Polarity

REMOVAL

1. Remove seat. See [2.28 SEAT](#).

⚠ WARNING

To prevent accidental vehicle start-up, which could cause death or serious injury, disconnect negative (-) battery cable before proceeding. (00048a)

2. Disconnect negative battery cable from battery.
3. See [Figure 7-42](#). Both diodes (1, 2) are mounted in the fuse block under the seat.
4. Remove faulty diode by pulling it straight up off the relay block.

INSTALLATION

1. See [Figure 7-42](#). Install the **new** diodes into position on the fuse block by pushing it into the slot.
2. Connect negative battery cable to battery terminal. Tighten fastener to 72-96 **in-lbs** (8-11 Nm).

⚠ WARNING

After installing seat, pull upward on front of seat to be sure it is in locked position. While riding, a loose seat can shift causing loss of control, which could result in death or serious injury. (00070a)

3. Install seat. See [2.28 SEAT](#).

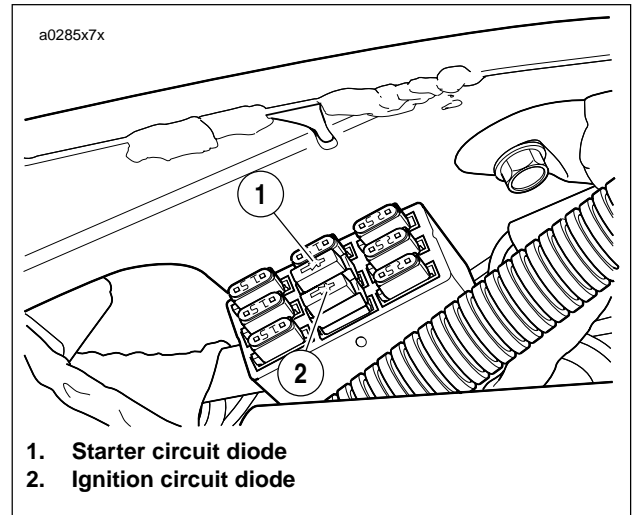


Figure 7-42. Diode Location in Fuse Block

GENERAL

The charging system consists of the alternator and regulator. Charging system circuits are shown in [Figure 7-45](#).

Alternator

The alternator consists of two main components:

- The rotor which mounts to the engine sprocket shaft.
- The stator which bolts to the engine crankcase.

Voltage Regulator

See [Figure 7-43](#). The voltage regulator is a series regulator with shunt control. The circuit combines the functions of rectifying and regulating.

TROUBLESHOOTING

When the charging system fails to charge or does not charge at a satisfactory rate, make the following recommended checks.

Battery

Check for a weak or dead battery. See [7.16 BATTERY](#). Battery must be fully charged in order to perform any electrical tests.

Wiring

Check for corroded or loose connections in the charging circuit. See [Figure 7-45](#).

Voltage Regulator Inspection

See [Figure 7-43](#). The voltage regulator base must have a clean, tight connection for proper grounding. The harness is grounded to the voltage regulator body. Check by using an ohmmeter with one lead on a known good ground, such as battery ground cable, and the other on the regulator base.

Connector plug to stator must be clean and tight.

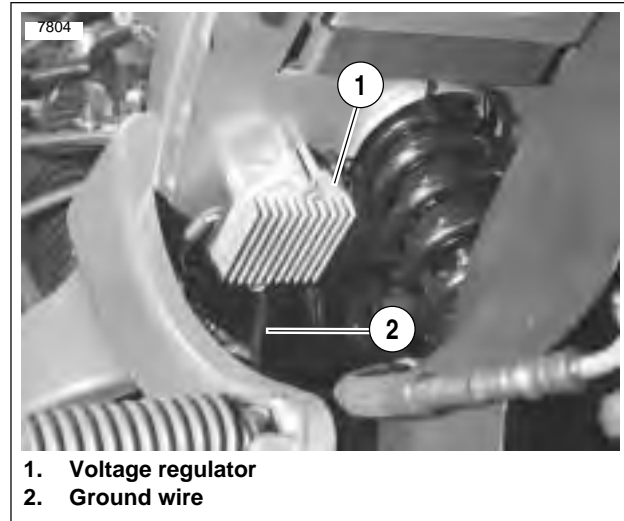


Figure 7-43. Voltage Regulator

NOTE
Whenever a charging system component fails a test and is replaced, re-test the system to be sure the problem has been corrected.

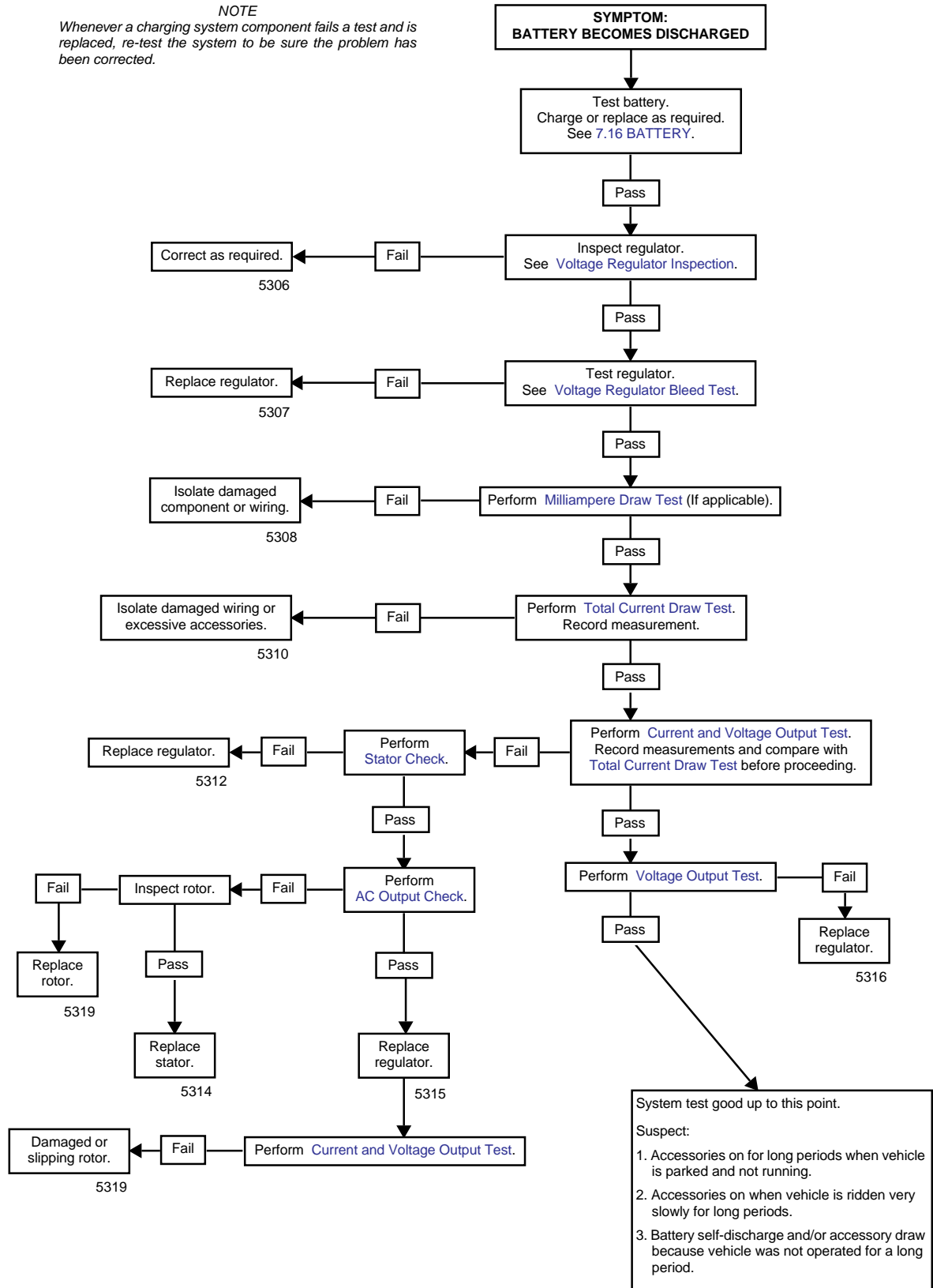


Figure 7-44. Charging System Troubleshooting

a0278x7x

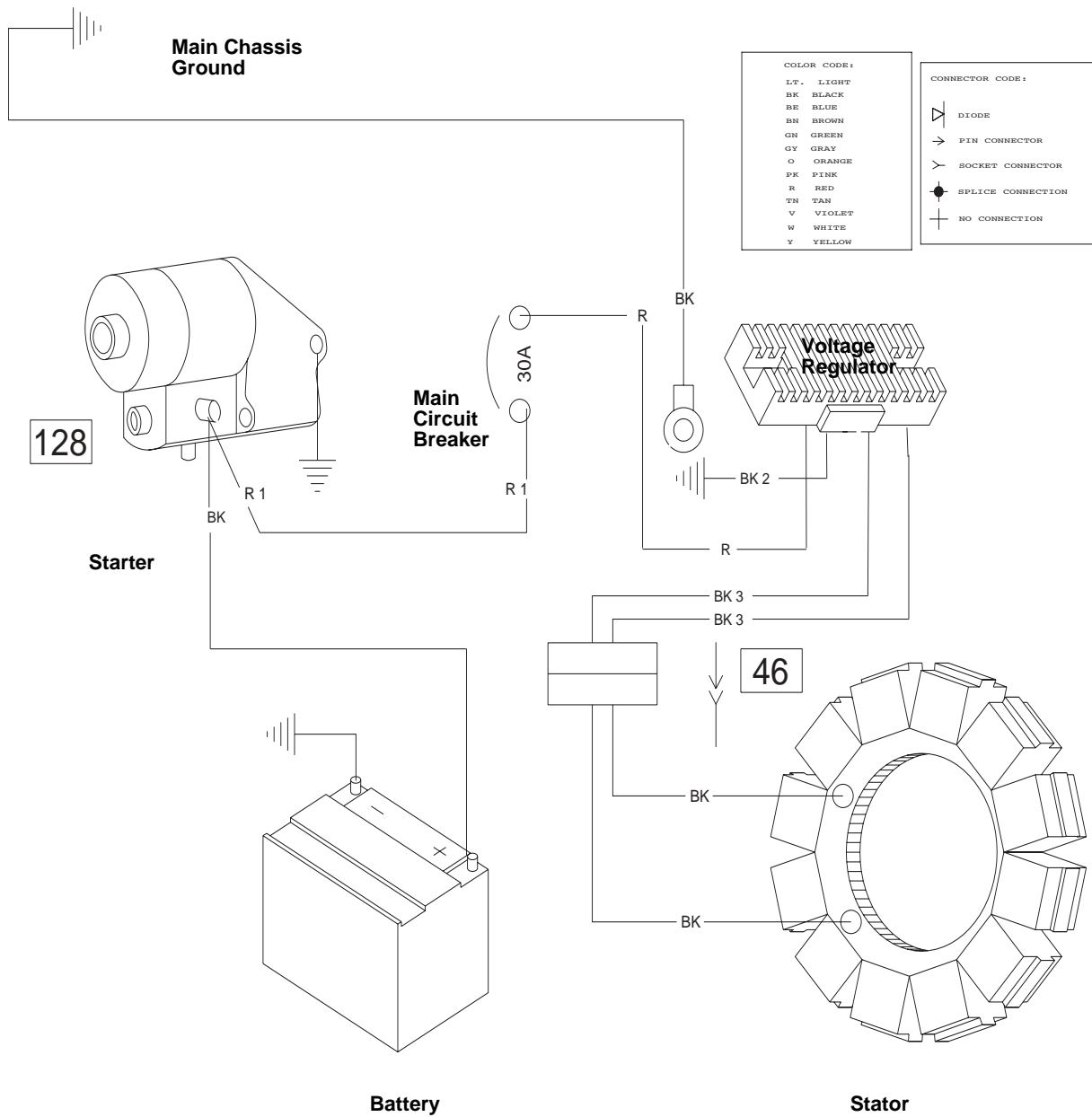


Figure 7-45. Charging System Circuit

TESTING

Voltage Regulator Bleed Test

1. Be sure regulator is connected to battery. Check BK charging wire on gold terminal of master circuit breaker.
2. Locate voltage regulator connector [46] behind left footrest support. Disconnect from alternator stator wiring. Cut cable strap and note its location.
3. Check regulator connector using a trouble light.
 - a. Touch one probe to a suitable ground.
 - b. Touch the other to the regulator pins, one at a time.
 - c. If light glows, replace regulator.

Milliampere Draw Test

NOTE

Be sure accessories are not wired so they stay on at all times. This condition could drain battery completely if vehicle is parked for a long time. Check for this by connecting ammeter between negative battery terminal and battery.

1. See Figure 7-46. Connect ammeter between negative battery terminal and battery. With this arrangement, you will also pick up any regulator drain.
2. With ignition key switch turned to OFF and all lights and accessories off, observe amperage reading.
 - a. Maximum reading should be 1 milliampere.
 - b. A higher reading indicates excessive current draw. Any accessories must be considered and checked for excessive drain.

NOTE

A battery with a surface discharge condition could suffer a static drain. Correct by cleaning battery case.

Total Current Draw Test

If battery runs down during use, the current draw of the motorcycle components and accessories may exceed output of the charging system.

1. See Figure 7-47. To check for this condition, place load tester induction pickup or current probe pickup over battery negative cable.
2. Disconnect stator wiring from voltage regulator wiring at the connector [46]. Start the motorcycle and run the engine at 2000 RPM.
3. With ignition and all continuously running lights and accessories turned on (headlamp on high beam), read the total current draw.
4. Compare this reading to the reading obtained after performing the [Current and Voltage Output Test](#).
 - a. The current output should exceed current draw by 3.5 amps minimum.
 - b. If output does not meet specifications, there may be too many accessories for the charging system to handle.
5. Reconnect regulator after testing. Replace cut cable strap.

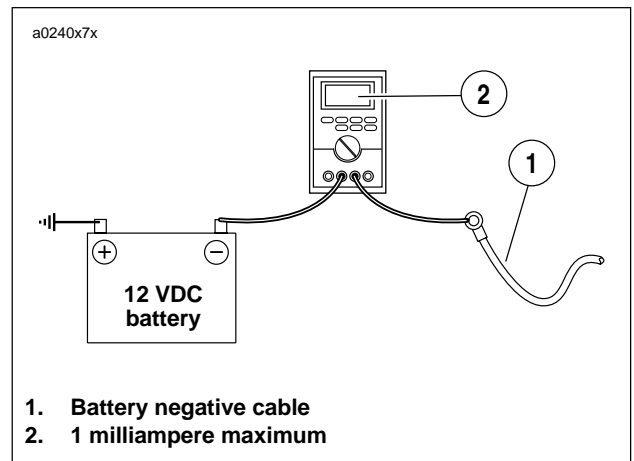


Figure 7-46. Milliampere Draw Test with Ignition Turned to OFF Position

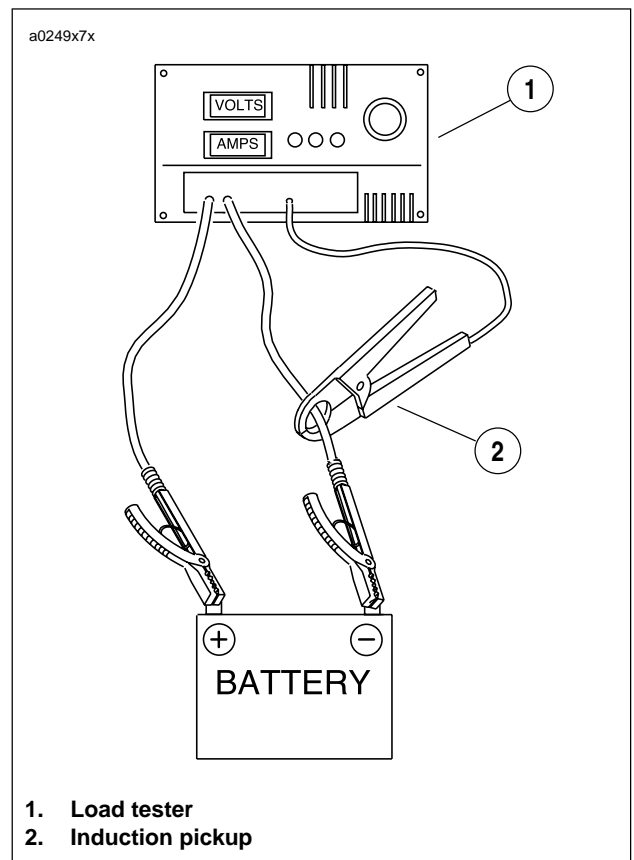


Figure 7-47. Checking Current Draw Using Load Tester with Induction Pickup (Ignition Switch ON)

Current and Voltage Output Test

1. See [Figure 7-48](#). Connect load tester.
 - a. Connect negative and positive leads to battery terminals.
 - b. Place load tester induction pickup over positive regulator cable.

IMPORTANT NOTE

Do not leave any load switch turned on for more than 20 seconds or overheating and tester damage are possible.

2. Run the engine at 2000 RPM. Increase the load as required to obtain a constant 13.0 VDC.
3. The current output should be 19-23 amps. Make note of measurement for use in [TOTAL CURRENT DRAW TEST](#).

NOTE

Rider's habits may require output test at lower RPM.

Voltage Output Test

1. See [Figure 7-48](#). After removing the load, read the load tester voltage meter.
2. See [Figure 7-44](#). If voltage to the battery is not more than 15 VDC, voltage output is within specifications. Investigate other possible problems.
3. If voltage is higher, regulator is not functioning properly or connections are loose or dirty.

Stator Check

1. Turn ignition key switch to OFF.
2. See [Figure 7-49](#). Connect an ohmmeter.
 - a. Locate voltage regulator connector [46] behind left footrest support. Disconnect from alternator stator wiring.
 - b. Insert one ohmmeter lead into either stator socket.
 - c. Attach the other lead to a suitable ground.
3. Test for continuity with ohmmeter set on the RX1 scale.
 - a. A good stator will show no continuity (∞ ohms) across either stator socket.
 - b. Any other reading indicates a grounded stator which must be replaced.
4. See [Figure 7-50](#). Remove ground lead. Insert lead into the remaining stator socket.
5. Test for resistance with ohmmeter set on the RX1 scale.
 - a. Resistance across the stator sockets should be 0.2-0.4 ohms.
 - b. If the resistance is lower, the stator is damaged and must be replaced.

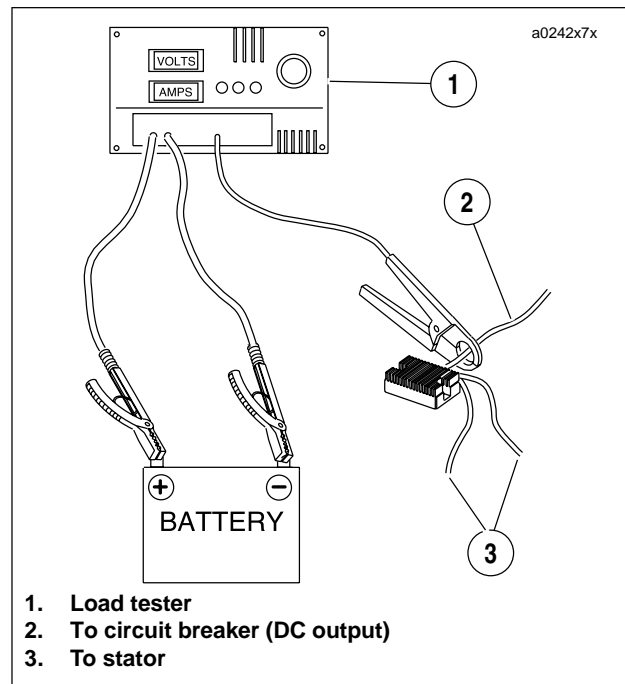


Figure 7-48. Current and Voltage Output Test

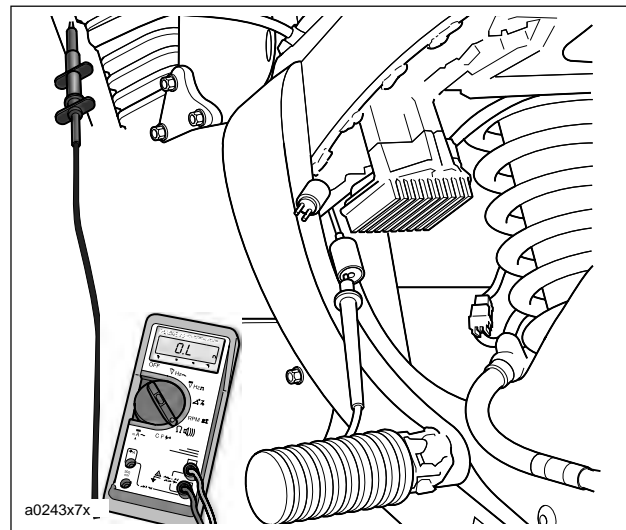


Figure 7-49. Test for Grounded Stator

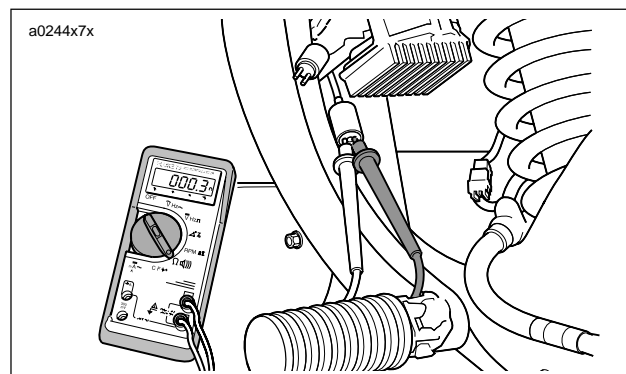


Figure 7-50. Check for Stator Resistance

AC Output Check

1. See [Figure 7-51](#). Test AC output.
 - a. Locate voltage regulator connector [46] behind left footrest support. Disconnect from alternator stator wiring.
 - b. Connect an AC voltmeter across both stator sockets.
 - c. Run the engine at 2000 RPM. The AC output should be 38-52 volts AC.
2. Compare test results to specifications.
 - a. If the output is below specifications, charging problem could be a faulty rotor or stator.
 - b. If output is good, charging problem might be faulty regulator/rectifier. Replace as required.
3. Check the output again as described under [Current and Voltage Output Test](#).

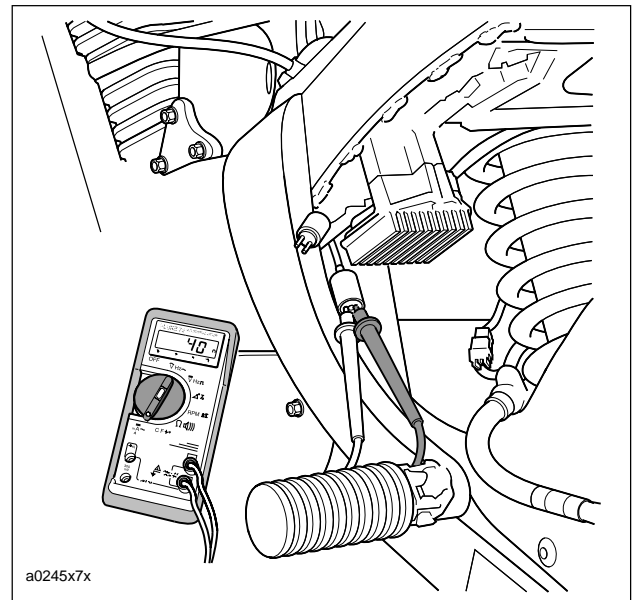


Figure 7-51. Check Stator AC Voltage Output

REMOVAL/DISASSEMBLY

1. Remove seat. See 2.28 SEAT.

WARNING

To prevent accidental vehicle start-up, which could cause death or serious injury, disconnect negative (-) battery cable before proceeding. (00048a)

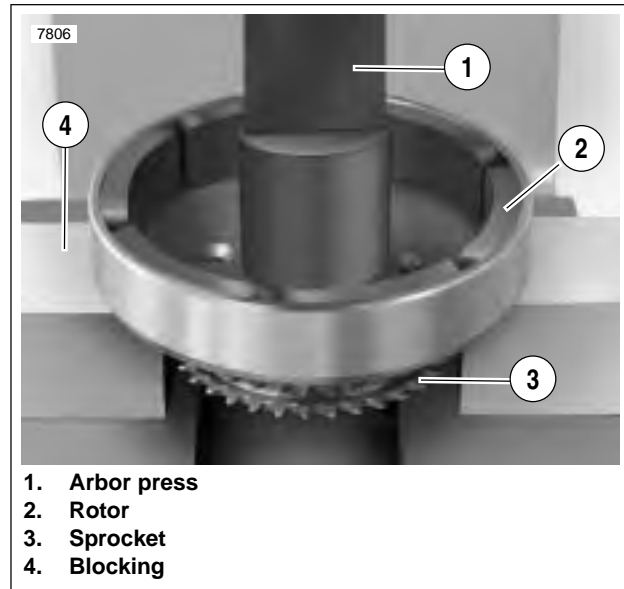
2. Disconnect negative battery cable from battery.
3. Remove primary cover. See 6.2 PRIMARY CHAIN.
4. Remove clutch assembly, primary chain and engine sprocket/rotor assembly as a unit. See 6.4 PRIMARY DRIVE/CLUTCH.
5. Remove/disassemble rotor and/or stator, as required. Refer to the following procedures.

Rotor

1. See Figure 7-52. Remove the eight bolts which secure alternator rotor to engine sprocket.



Figure 7-52. Rotor Assembly



1. Arbor press
2. Rotor
3. Sprocket
4. Blocking

Figure 7-53. Removing Rotor From Sprocket

2. See Figure 7-53. Position blocking under rotor. Press sprocket free of rotor.

NOTE

Resistance to sprocket/rotor disassembly is due in part to the magnetic force of the permanent rotor magnets.

Stator

1. See Figure 7-54. Disconnect stator wiring from voltage regulator wiring at connector [46] located behind left foot-rest support.

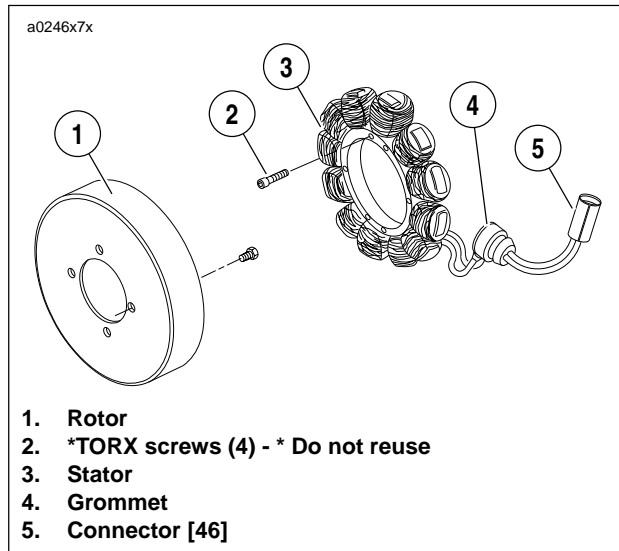


Figure 7-54. Stator Assembly

2. Remove cable straps holding stator wire to oil filter hose.
3. Withdraw stator wiring from behind the gearcase cover.
4. Remove and discard the four TORX screws which secure stator to left crankcase half.

IMPORTANT NOTE

Stator TORX screws contain a thread locking compound. Do not reuse existing screws. Always use new screws with the proper thread locking compound. Loss of torque on TORX fasteners could result in alternator damage.

5. Remove stator wiring grommet from left crankcase half.
6. Withdraw stator wiring from grommet hole in left crankcase half. Remove stator.

CLEANING AND INSPECTION

IMPORTANT NOTE

Do not strike or drop alternator rotor or damage to magnet adhesive could occur. Magnet adhesive damage can result in rotor failure.

1. Clean rotor with a petroleum-base solvent. Remove all foreign material from rotor magnets. Replace rotor if rotor magnets are cracked or loose.
2. Clean stator by wiping with a clean cloth.
3. Examine stator leads for cracked or damaged insulation.

NOTE

The rotor and stator can be replaced individually if either is damaged.

ASSEMBLY/INSTALLATION

Depending on whether the rotor, the stator, or both the rotor and stator were removed/disassembled, perform the applicable procedures which follow:

1. See [Figure 7-54](#). Feed stator wiring with attached grommet into open grommet hole in left crankcase half.
2. Apply a light coating of clean engine oil or chaincase lubricant to grommet. Install grommet into hole in left crankcase half.

IMPORTANT NOTE

Stator TORX screws contain a thread locking compound. Do not reuse existing screws. Always use new screws with the proper thread locking compound. Loss of torque on TORX fasteners could result in alternator damage.

3. Position stator on left crankcase half. Secure stator using four **new** TORX screws. Tighten screws to 30-40 **in-lbs** (3-5 Nm).
4. Route stator wiring under starter, behind footpeg support bracket and under seat. Cable strap connector [46] halves together.

NOTE

Temporarily attach a thin flexible "feed" or mechanic's wire to the connector end of the stator wiring to assist in the routing of the wiring.

5. Connect alternator stator wiring to voltage regulator connector [46] located behind left footrest support.

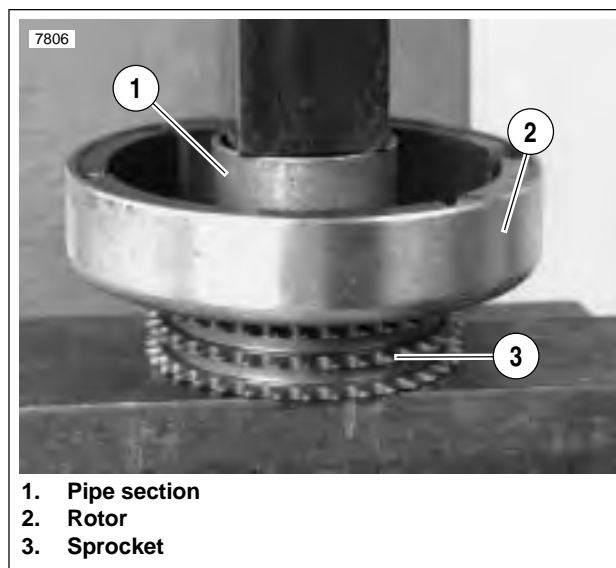


Figure 7-55. Pressing Rotor onto Sprocket

6. See [Figure 7-55](#). Attach rotor to sprocket.
 - a. Position rotor on sprocket. Align holes in sprocket with holes in rotor.
 - b. Apply a drop of Loctite 243 (blue) to threads of each mounting bolt. Insert the eight mounting bolts through rotor and start bolts into tapped holes in sprocket.
 - c. Position a section of pipe with an inside diameter larger than the sprocket mounting hub over center of rotor. Press rotor onto sprocket. Tighten bolts to 90-110 **in-lbs** (10-12 Nm).
7. Install clutch assembly, primary chain and engine sprocket/rotor assembly as a unit. See [6.4 PRIMARY DRIVE/CLUTCH](#).
8. Install primary cover. See [6.2 PRIMARY CHAIN](#).
9. Connect negative battery cable to battery terminal. Tighten fastener to 72-96 **in-lbs** (8-11 Nm).
10. Test charging system. See [7.13 CHARGING SYSTEM](#).

WARNING

After installing seat, pull upward on front of seat to be sure it is in locked position. While riding, a loose seat can shift causing loss of control, which could result in death or serious injury. (00070a)

11. Install seat. See [2.28 SEAT](#).

GENERAL

The voltage regulator is located under the frame (above swingarm on left side). The voltage regulator is not repairable. Replace the unit if it fails.

REMOVAL

1. Remove seat. See 2.28 SEAT.

WARNING

To prevent accidental vehicle start-up, which could cause death or serious injury, disconnect negative (-) battery cable before proceeding. (00048a)

2. Disconnect negative battery cable from battery terminal.

IMPORTANT NOTE

When disconnecting the alternator stator wiring, pull apart the connector by firmly grasping both connector halves. Do not pull on leads or damage to the wires and/or terminals could result.

3. See Figure 7-56. Locate voltage regulator connector [46] behind left footrest support. Disconnect from alternator stator wiring. Cut cable straps if necessary.
4. Detach charging wire from main circuit breaker.
 - a. See Figure 7-57. Disconnect red charging wire from gold post of main circuit breaker.
 - b. Route charging wire back to voltage regulator.
5. Remove two mounting screws.
6. Remove and discard voltage regulator.

INSTALLATION

1. Apply Loctite 243 (blue) to threads of two mounting screws.
2. See Figure 7-57. Attach **new** voltage regulator using two screws. Tighten screws to 48-72 **in-lbs** (5-8 Nm).
3. Connect voltage regulator connector [46] to alternator stator wiring. Cable strap connector halves together.
4. Route Red charging wire to gold post on main circuit breaker. Secure wire to frame with **new** cable straps.
5. Connect negative battery cable to battery terminal. Tighten fastener to 72-96 **in-lbs** (8-11 Nm).
6. Test charging system. See 7.13 CHARGING SYSTEM.

WARNING

After installing seat, pull upward on front of seat to be sure it is in locked position. While riding, a loose seat can shift causing loss of control, which could result in death or serious injury. (00070a)

7. Install seat. See 2.28 SEAT.

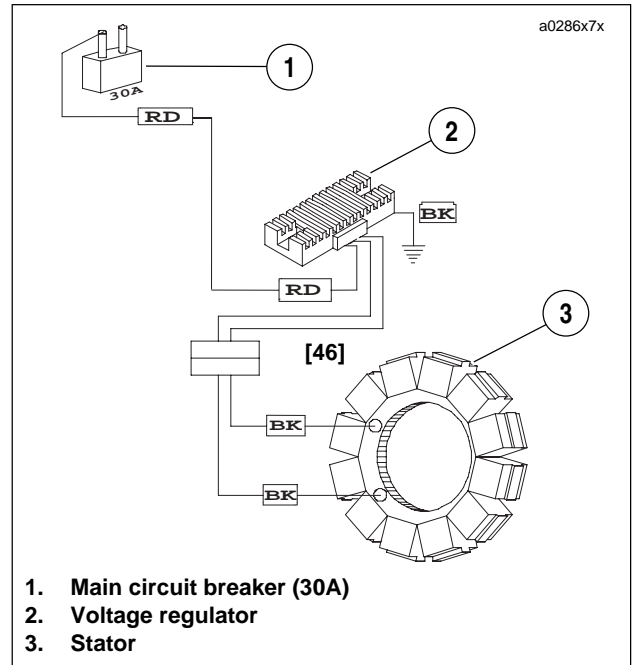


Figure 7-56. Voltage Regulator Connector [46]

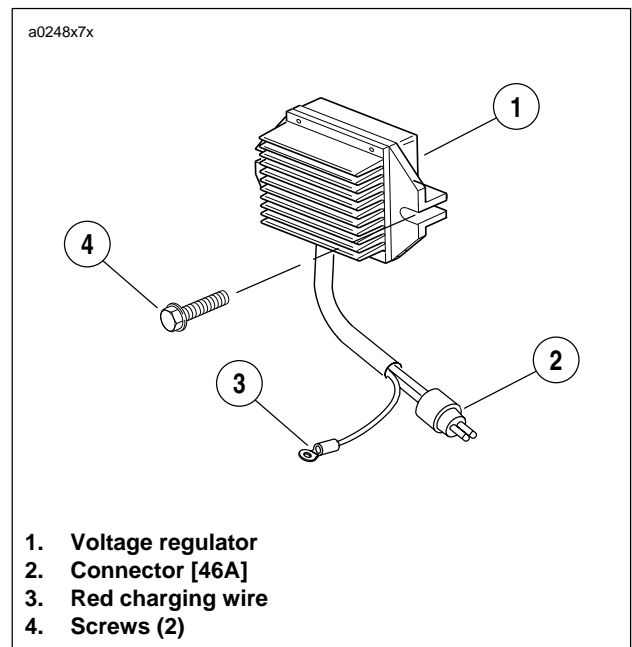


Figure 7-57. Voltage Regulator

GENERAL

All Buell batteries are permanently sealed, maintenance-free, valve-regulated, lead/calcium and sulfuric acid batteries. The batteries are shipped pre-charged and ready to be put into service. Do not attempt to open these batteries for any reason.

WARNING

Batteries contain sulfuric acid, which could cause severe burns to eyes and skin. Wear a protective face shield, rubberized gloves and protective clothing when working with batteries. **KEEP BATTERIES AWAY FROM CHILDREN.** (00063a)

WARNING

Figure 7-58. Never remove warning label attached to top of battery. Failure to read and understand all precautions contained in warning, could result in death or serious injury. (00064a)



Figure 7-58. Battery Warning Label Location

Table 7-20. Battery Electrolyte Antidotes

CONTACT	SOLUTION
External	Flush with water.
Internal	Drink large quantities of milk or water, followed by milk of magnesia, vegetable oil or beaten eggs. Call doctor immediately.
Eyes	Flush with water, get immediate medical attention.

b1184x7x

1. Contents are corrosive.
2. Wear safety glasses.
3. Contents are explosive.
4. Keep flames away.
5. Read instructions.
6. Keep away from children.

Figure 7-59. Battery Warning Label

BATTERY TESTING

Voltmeter Test

See [Table 7-21](#). The voltmeter test provides a general indicator of battery condition. Check the voltage of the battery to verify that it is in a 100% fully charged condition. If the open circuit (disconnected) voltage reading is below 12.6V, charge the battery and then recheck the voltage after the battery has set for one to two hours. If the voltage reading is 12.7V or above, perform the load test.

Table 7-21. Battery Charge Conditions

Voltage (OCV)	State of Charge
12.7	100%
12.6	75%
12.3	50%
12.0	25%
11.8	0%

Load Test

The load test measures battery performance under full current load and is the best indicator of battery condition. To load test the battery, proceed as follows:

IMPORTANT NOTE

Load testing a discharged battery can result in permanent battery damage.

1. Always fully charge the battery before testing or test readings will be incorrect. See [BATTERY INSTALLATION AND CONNECTION](#). Load testing a discharged battery can also result in permanent battery damage.
2. After charging, allow battery to stand for at least one hour before testing.

WARNING

Turn battery load tester OFF before connecting tester cables to battery terminals. Connecting tester cables with load tester ON can cause a spark and battery explosion, which could result in death or serious injury. (00252a)

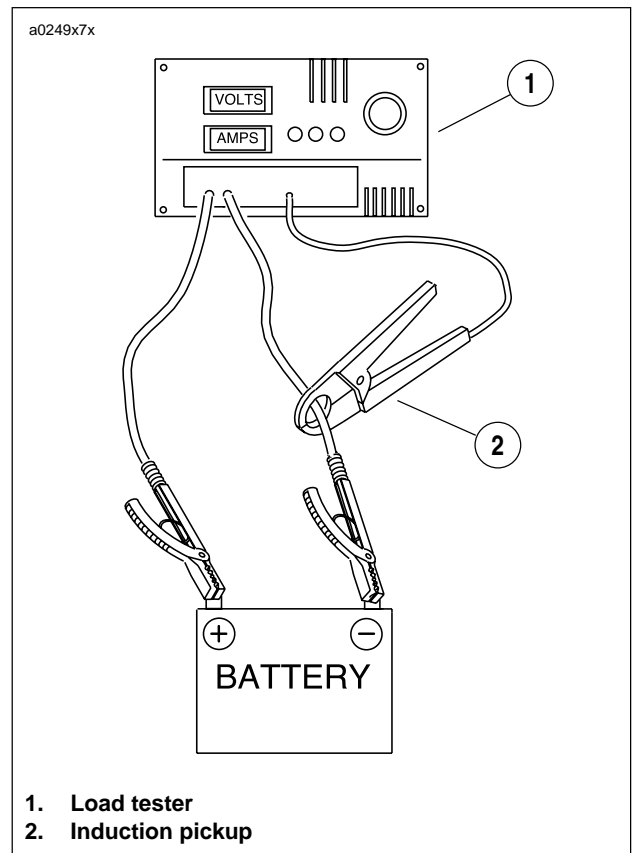


Figure 7-60. Load Test Battery

3. See [Figure 7-60](#). Connect tester leads to battery posts and place induction pickup over negative (black) cable.

IMPORTANT NOTE

To avoid load tester and/or battery damage, do not leave the load tester switch turned ON for more than 20 seconds.

4. See [Figure 7-60](#). Load battery at 50% of CCA rating using the load tester. Voltage reading after 15 seconds should be 9.6V or more at 70° F. (21° C).

Table 7-22. Battery Load Test

COLD CRANKING AMPERAGE (CCA)	100%	50%
BLAST	200	100

WARNING

Turn battery load tester OFF before disconnecting tester cables to battery terminals. Disconnecting tester cables with load tester ON can cause a spark and battery explosion, which could result in death or serious injury. (00253a)

5. Install the battery on the motorcycle. See [BATTERY INSTALLATION AND CONNECTION](#).

DISCONNECTION AND REMOVAL

1. Remove seat. See [2.28 SEAT](#).

WARNING

To prevent accidental vehicle start-up, which could cause death or serious injury, disconnect battery cables (negative (-) cable first) before proceeding. (00307a)

WARNING

Disconnect negative (-) battery cable first. If positive (+) cable should contact ground with negative (-) cable connected, the resulting sparks can cause a battery explosion, which could result in death or serious injury. (00049a)

2. Unthread bolt and remove battery negative cable (black) from battery negative (-) terminal.
3. Unthread bolt and remove battery positive cable (red) from battery positive (+) terminal.
4. Remove battery from motorcycle.

CLEANING AND INSPECTION

1. Battery top must be clean and dry. Dirt and electrolyte on top of the battery can cause battery to self-discharge. Clean battery top with a solution of baking soda (sodium bicarbonate) and water (5 teaspoons baking soda per quart or liter of water). When the solution stops bubbling, rinse off the battery with clean water.
2. Clean cable connectors and battery terminals using a wire brush or sandpaper. Remove any oxidation.
3. Inspect the battery screws, clamps and cables for breakage, loose connections and corrosion. Clean clamps.
4. Check the battery posts for melting or damage caused by overtightening.
5. Inspect the battery for discoloration, raised top or a warped or distorted case, which might indicate that the battery has been frozen, overheated or overcharged.
6. Inspect the battery case for cracks or leaks.

BATTERY CHARGING

Safety Precautions

Never charge a battery without first reviewing the instructions for the charger being used. In addition to the manufacturer's instructions, follow these general safety precautions:

- Always wear proper eye, face and hand protection.
- Always charge batteries in a well-ventilated area.
- Turn the charger "OFF" before connecting the leads to the battery to avoid dangerous sparks.
- Never try to charge a visibly damaged or frozen battery.

- Connect the charger leads to the battery; red positive (+) lead to the positive (+) terminal and black negative (-) lead to the negative (-) terminal. If the battery is still in the vehicle, connect the negative lead to the chassis ground. Be sure that the ignition and all electrical accessories are turned off.
- Make sure that the charger leads to the battery are not broken, frayed or loose.
- If the battery becomes hot, or if violent gassing or spewing of electrolyte occurs, reduce the charging rate or turn off the charger temporarily.
- Always turn the charger "OFF" before removing charger leads from the battery to avoid dangerous sparks.

Charging Battery

Charge the battery if any of the following conditions exist:

- Vehicle lights appear dim.
- Electric starter sounds weak.
- Battery has not been used for an extended period of time.

WARNING

Explosive hydrogen gas, which escapes during charging, could cause death or serious injury. Charge battery in a well-ventilated area. Keep open flames, electrical sparks and smoking materials away from battery at all times. KEEP BATTERIES AWAY FROM CHILDREN. (00065a)

IMPORTANT NOTE

If the battery releases an excessive amount of gas during charging, decrease the charging rate. If the battery gets hotter than 110°F. (43°C) during charging, discontinue charging and allow the battery to cool. Overheating may result in plate distortion, internal shorting, dry out or other damage.

1. Perform a voltmeter test to determine the state of charge. See BATTERY TESTING, VOLTMETER TEST.

WARNING

Connect positive (+) battery cable first. If positive (+) cable should contact ground with negative (-) cable connected, the resulting sparks can cause a battery explosion, which could result in death or serious injury. (00068a)

CAUTION

Remove battery from motorcycle before charging. Electrolyte leakage will damage motorcycle parts. (00213a)

2. Install the battery on the motorcycle. See [BATTERY INSTALLATION AND CONNECTION](#).

BATTERY CABLE ROUTING

Positive battery cable runs from the starter post to the positive battery terminal. Negative battery cable runs from frame to negative battery terminal.

NOTE

Route negative battery cable between battery and frame rail.

BATTERY INSTALLATION AND CONNECTION

1. Place the fully charged battery on the battery pad, terminal side facing up.

CAUTION

Connect the cables to the correct battery terminals. Failure to do so could result in damage to the motorcycle electrical system. (00215a)

WARNING

Connect positive (+) battery cable first. If positive (+) cable should contact ground with negative (-) cable connected, the resulting sparks can cause a battery explosion, which could result in death or serious injury. (00068a)

CAUTION

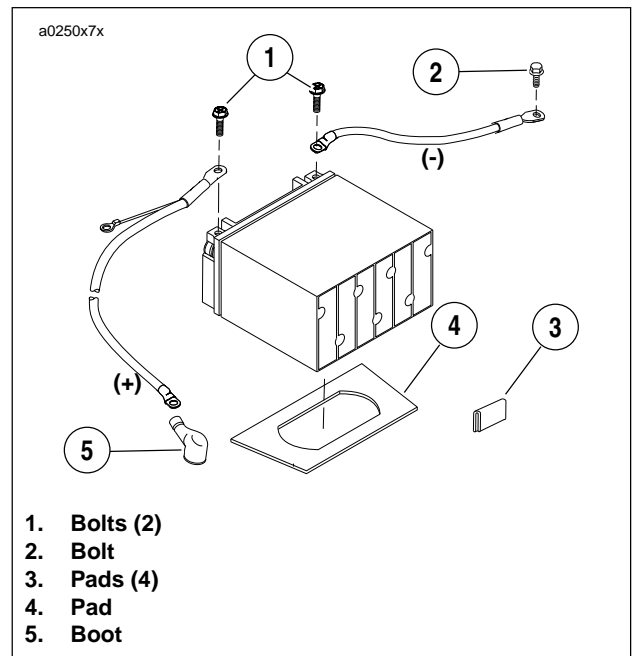
Do not over-tighten bolts on battery terminals. Use recommended torque values. Over-tightening battery terminal bolts could result in damage to battery terminals. (00216a)

2. See [Figure 7-61](#). Insert bolt through battery positive cable (red) into threaded hole of battery positive (+) terminal. Tighten bolt to 72-96 **in-lbs** (8-11 Nm).
3. Insert bolt through battery negative cable (black) into threaded hole of battery negative (-) terminal. Tighten bolt to 72-96 **in-lbs** (8-11 Nm).
4. Apply a light coat of petroleum jelly or corrosion retardant material to both battery terminals.

WARNING

After installing seat, pull upward on front of seat to be sure it is in locked position. While riding, a loose seat can shift causing loss of control, which could result in death or serious injury. (00070a)

5. Install seat. See [2.28 SEAT](#).



1. Bolts (2)
2. Bolt
3. Pads (4)
4. Pad
5. Boot

Figure 7-61. Battery Installation

STORAGE

⚠ WARNING

Always store batteries where they cannot be reached by children. Contact with the battery's sulfuric acid could result in death or serious injury.

CAUTION

Do not allow battery to completely discharge. The electrolyte in a discharged battery will freeze. The more discharged a battery is, the more easily it can freeze and crack the battery case. (00218a)

If the motorcycle will not be operated for several months, such as during the winter season, remove the battery from the motorcycle and fully charge. See CHARGING BATTERY.

See Figure 7-62. Self-discharge is a normal condition and occurs continuously at a rate that depends on the ambient temperature and the battery's state of charge. Batteries discharge at a faster rate at higher ambient temperatures. To reduce the self-discharge rate, store battery in a cool (not freezing), dry place.

Charge the battery every month if stored at temperatures below 60° F. (16° C). Charge the battery more frequently if stored in a warm area above 60° F. (16° C).

NOTE

The H-D Battery Tender Automatic Battery Charger (P/N 99863-93TA) may be used to maintain battery charge for extended periods of time without risk of overcharging or boiling.

When returning a battery to service after storage, refer to the instructions under CHARGING BATTERY.

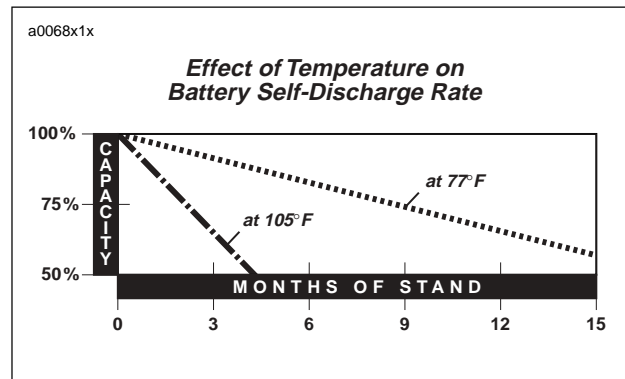


Figure 7-62. Battery Self-Discharge Rate

REMOVAL/DISASSEMBLY

Headlamp

NOTE

The headlamp is a sealed assembly. If bulb fails, replace headlamp.

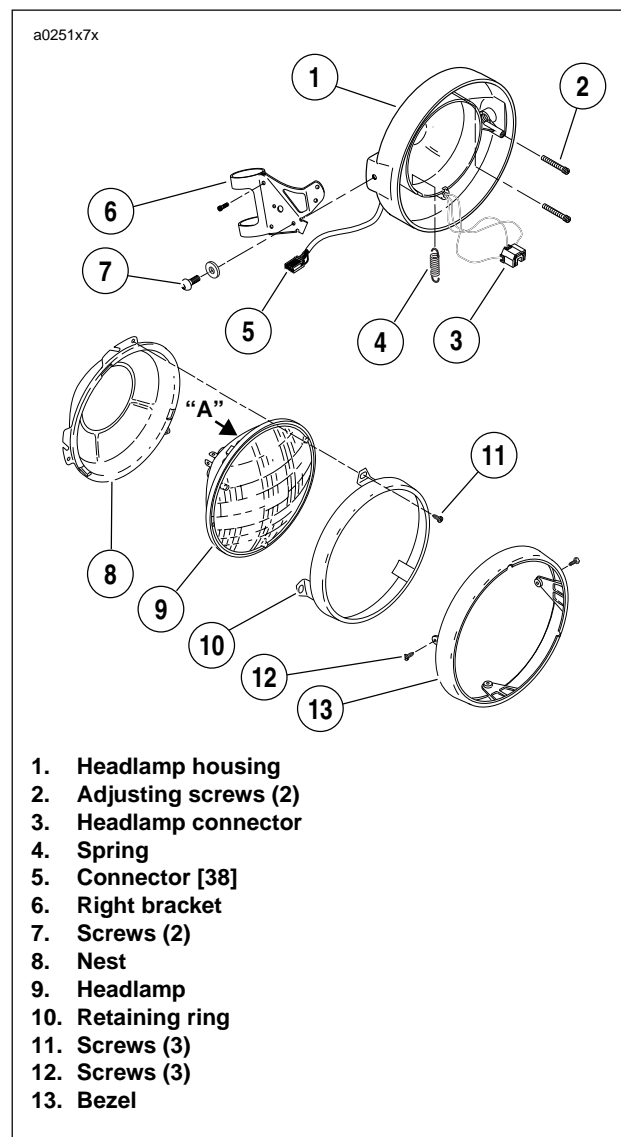
1. Remove four screws, washers and windscreen. See 2.26 WINDSCREEN.
2. See Figure 7-63. Remove three phillips head screws (12) and bezel (13) from nest.
3. Remove three screws (11) and retaining ring (10).
4. Slide headlamp (9) from headlamp housing (1) and detach headlamp connector (3) from rear of headlamp.

CAUTION

Handle bulb carefully and wear eye protection. Bulb contains Halogen gas under pressure, which, if not handled carefully, could cause serious eye injury. (00062a)

Headlamp Housing and Brackets

1. See Figure 7-63. Remove two screws (7) and washers and partially remove headlamp housing (1) from vehicle.
2. Detach connector [38] (5) from wiring harness. Remove headlamp housing from vehicle.
3. To remove nest (8), remove two adjusting screws (2) and detach spring from nest.
4. Remove headlamp brackets (6).
 - a. Remove front turn signals. See 7.19 TURN SIGNALS.
 - b. Remove two screws from bracket.
 - c. Repeat for other bracket.
 - d. Remove front forks and headlamp brackets. See 2.17 FRONT FORK.
 - e. Remove windscreen from brackets. See 2.26 WINDSCREEN.



1. Headlamp housing
2. Adjusting screws (2)
3. Headlamp connector
4. Spring
5. Connector [38]
6. Right bracket
7. Screws (2)
8. Nest
9. Headlamp
10. Retaining ring
11. Screws (3)
12. Screws (3)
13. Bezel

Figure 7-63. Headlamp Assembly

ASSEMBLY/INSTALLATION

Headlamp Housing and Brackets

1. Install headlamp brackets.
 - a. Install front forks through triple clamps and brackets. See 2.17 FRONT FORK.
 - b. See Figure 7-63. Install bracket (6) with two allen screws and tighten to 12-14 ft lbs (16.3-19.0).
 - c. Repeat for other bracket
 - d. Attach front turn signals. See 7.19 TURN SIGNALS.
 - e. Install windscreen if removed with four screws and washers. See 2.26 WINDSCREEN.
2. See Figure 7-63. Mate connector [38] (5) to wiring harness.
3. Install headlamp housing (1) using two screws (7) and washers. Tighten to 12-14 ft-lbs (16.3-19 Nm).

Headlamp

CAUTION

Handle bulb carefully and wear eye protection. Bulb contains Halogen gas under pressure, which, if not handled carefully, could cause serious eye injury. (00062a)

1. See [Figure 7-63](#). Connect headlamp connector (3) to rear of headlamp (9).

NOTE

Align protrusion "A" on headlamp with slot in upper portion of nest for proper fit. Retaining ring only fits one way. Rotate retaining ring until all three holes align.

2. Install headlamp and retaining ring (10) to nest with three phillips screws (11). Tighten screws to 12-14 **in-lbs** (1-2 Nm).

NOTE

Make sure slots on bezel are positioned so they allow access to adjusting screws.

3. Install bezel (13) to retaining ring with three phillips screws (12). Tighten screws to 12-14 **in-lbs** (1-2 Nm).
4. Install windscreen with four screws and washers. See [2.26 WINDSCREEN](#).

WARNING

Be sure that all lights and switches operate properly before operating motorcycle. Low visibility of rider can result in death or serious injury. (00316a)

5. See [Figure 7-64](#). Check headlamp for proper operation.
 - a. Turn ignition key switch to IGN.
 - b. Check headlamp LOW (3) and HIGH (2) beam settings.
 - c. Set headlamp to LOW beam. Press highbeam flash switch (4). Headlamp should flash HIGH beam for as long as the switch is pressed.
 - d. Turn ignition key switch to OFF.
 - e. If operation fails, reread procedure and verify that all steps were performed.
6. Align headlamp. See [1.22 HEADLAMP](#).

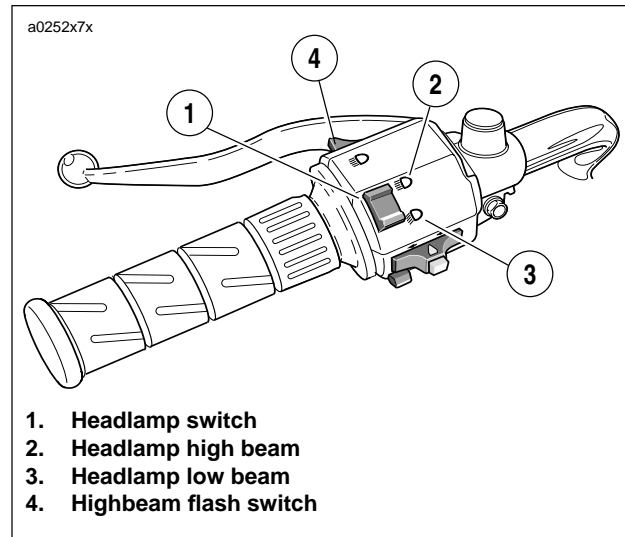


Figure 7-64. Headlamp Switch

BULB REPLACEMENT

1. See [Figure 7-65](#). Remove two screws (1) and lens (2).
2. Rotate bulb (3) counterclockwise and pull to remove.
3. Install **new** tail lamp bulb by pushing into socket and rotating bulb clockwise.
4. Install tail lamp lens with two screws.

REMOVAL

1. See [Figure 7-65](#). Disconnect the tail lamp connector (7) from rear of tail lamp under tail section.
2. Remove two locknuts (metric) (5), washers (4) and tail lamp.

INSTALLATION

NOTE

Push up on metal bracket under tail section to align tail lamp mounting holes.

1. See [Figure 7-65](#). Attach tail lamp to tail section with two washers (4) and locknuts (metric) (5). Tighten locknuts to 23-28 **in-lbs** (2.6-3.2 Nm).
2. Attach the tail lamp connector (7) to the back of the tail lamp.

⚠ WARNING

Be sure that all lights and switches operate properly before operating motorcycle. Low visibility of rider can result in death or serious injury. (00316a)

3. Check tail lamp for proper operation. If operation fails, reread procedure and verify that all steps were performed.
 - a. Turn ignition key switch to IGN.
 - b. Check for tail lamp illumination.
 - c. Squeeze front brake hand lever. Check for brake lamp illumination. Release front brake hand lever.
 - d. Press rear brake pedal. Check for brake lamp illumination. Release rear brake pedal.
 - e. Turn ignition key switch to OFF.

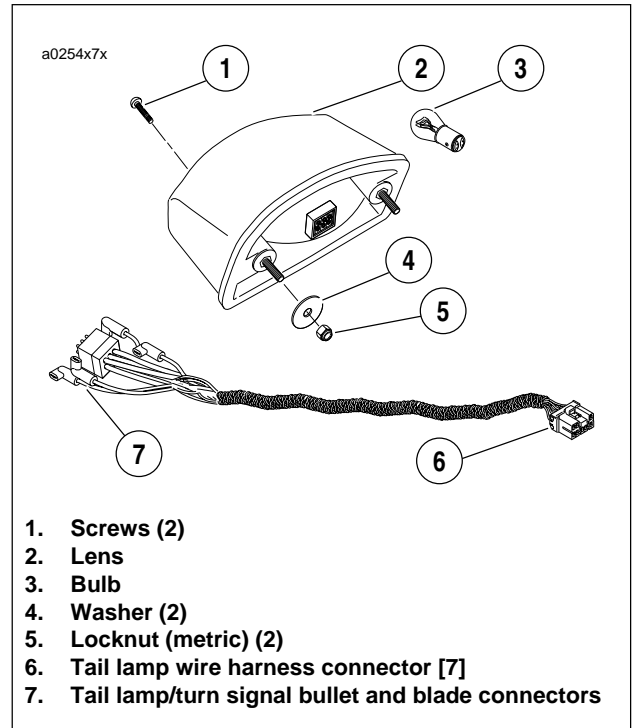


Figure 7-65. Tail Lamp

REMOVAL

NOTES

- Remove screw on back of turn signal to detach lens and install **new** turn signal bulbs.
- Front bulbs are identical to rear bulbs.

Front

1. Remove four screws, washers and windscreen. See 2.26 WINDSCREEN.
2. See Figure 7-66. Disconnect two bullet connectors on turn signal wires.
3. See Figure 7-67. Remove nut and lock washer.
4. Remove turn signal from headlamp bracket.
5. Repeat steps 2-4 for other turn signal.

Rear

1. Cut cable strap that secures bullet connectors under tail section.
2. See Figure 7-68. Disconnect two bullet connectors on turn signal wires.
3. Remove nut and lockwasher.
4. Remove turn signal from tail lamp bracket.
5. Repeat steps 2-4 for other turn signal.

INSTALLATION

Front

1. See Figure 7-67. Install turn signal with lock washer and nut. Tighten nut to 25-28 **in-lbs** (2.8-3.2 Nm).

NOTE

Install turn signal with lens drain hole facing downward.

2. Attach two bullet connectors on turn signal wires as shown in Figure 7-66.
3. Install four screws, washers and windscreen. See 2.26 WINDSCREEN.

WARNING

Be sure that all lights and switches operate properly before operating motorcycle. Low visibility of rider can result in death or serious injury. (00316a)

4. Check turn signals for proper operation. If operation fails, reread procedure and verify that all steps were performed.
 - a. Turn ignition key switch to IGN.
 - b. Activate left turn signals using switch on left handlebar. Front and rear left turn signals must flash.
 - c. Activate right turn signals using switch on left handlebar. Front and rear right turn signals must flash.
 - d. Turn ignition key switch to OFF.

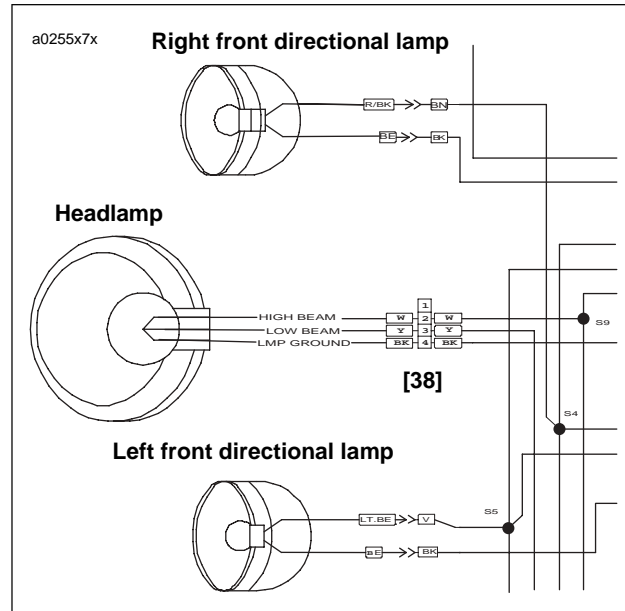


Figure 7-66. Front Turn Signal Connections

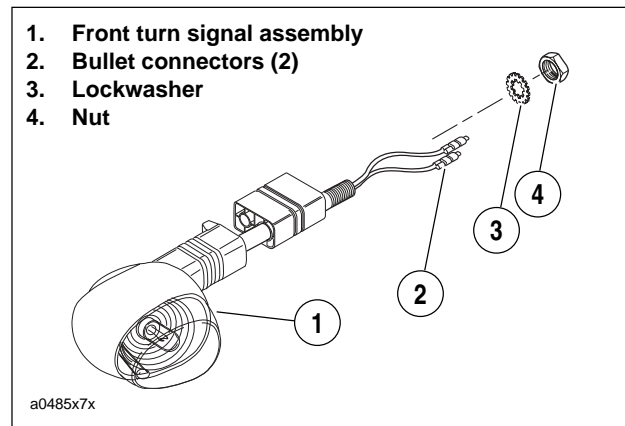


Figure 7-67. Front Turn Signals

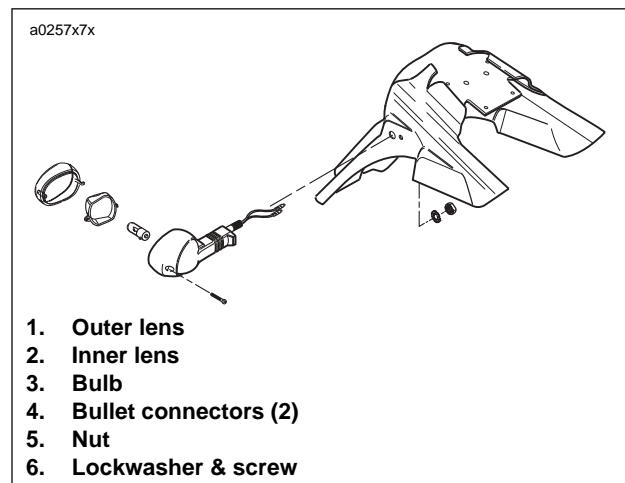


Figure 7-68. Rear Turn Signals

Rear

- See Figure 7-68. Insert bullet connectors through rear hole in tail lamp bracket. Attach turn signal using lock washer and nut. Tighten nut to 25-28 **in-lbs** (2.8-3.2 Nm).

NOTE

Install turn signal with lens drain hole facing downward.

- Attach two bullet connectors on turn signal wires as shown in Figure 7-69.
- Use **new** cable strap to bundle turn signal wires beneath tail section.

WARNING

Be sure that all lights and switches operate properly before operating motorcycle. Low visibility of rider can result in death or serious injury. (00316a)

- Check turn signals for proper operation. If operation fails, reread procedure and verify that all steps were performed.
 - Turn ignition key switch to IGN.
 - Activate left turn signals using switch on left handlebar. Front and rear left turn signals must flash.
 - Activate right turn signals using switch on left handlebar. Front and rear right turn signals must flash.
 - Turn ignition key switch to OFF.

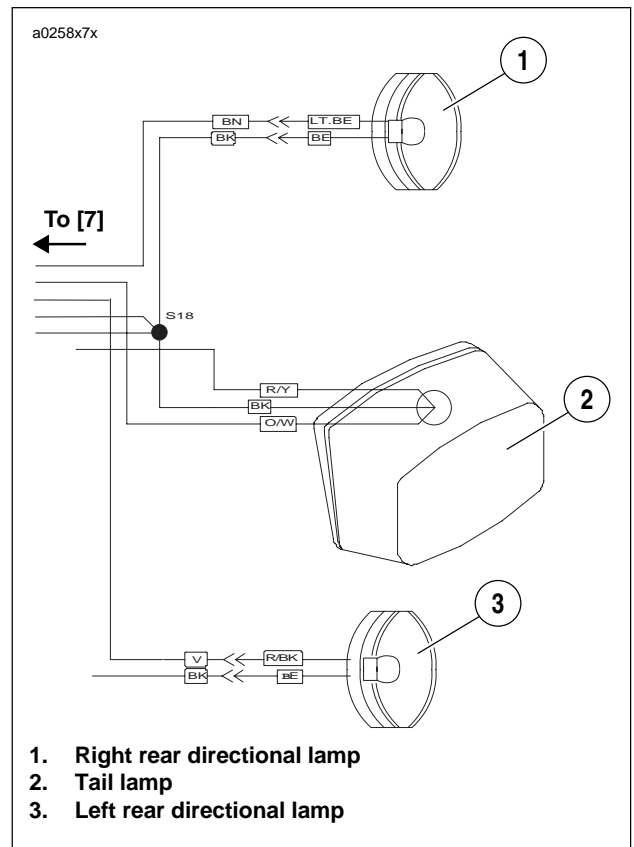


Figure 7-69. Rear Turn Signal Connections

REMOVAL

NOTE

The turn signal flasher is not repairable. Replace the unit if it fails.

1. Remove seat. See [2.28 SEAT](#).

WARNING

Disconnect negative (-) battery cable first. If positive (+) cable should contact ground with negative (-) cable connected, the resulting sparks can cause a battery explosion, which could result in death or serious injury. (00049a)

2. Disconnect negative battery cable.
3. Pry tab on circuit breaker clip left side and remove circuit breaker from clip with wires still attached.
4. See [Figure 7-70](#). Remove screw and flasher relay from frame tray.
5. Unplug relay connector [30] from flasher relay and remove flasher relay.

INSTALLATION

1. See [Figure 7-70](#). Connect relay connector [30] to **new** turn signal flasher relay.
2. Attach flasher relay to frame tray with screw. Tighten screw to 48-60 **in-lbs** (5.4-8 Nm).
3. Install circuit breaker to clip.
4. Connect negative battery cable to battery terminal. Tighten fastener to 72-96 **in-lbs** (8-11 Nm).

WARNING

Be sure that all lights and switches operate properly before operating motorcycle. Low visibility of rider can result in death or serious injury. (00316a)

5. Check turn signals for proper operation. If operation fails, reread procedure and verify that all steps were performed.
 - a. Turn ignition key switch to IGN.
 - b. Activate left turn signals using switch on left handlebar. Front and rear left turn signals must flash.
 - c. Activate right turn signals using switch on left handlebar. Front and rear right turn signals must flash.
 - d. Turn ignition key switch to OFF.

WARNING

After installing seat, pull upward on front of seat to be sure it is in locked position. While riding, a loose seat can shift causing loss of control, which could result in death or serious injury. (00070a)

6. Install seat. See [2.28 SEAT](#).

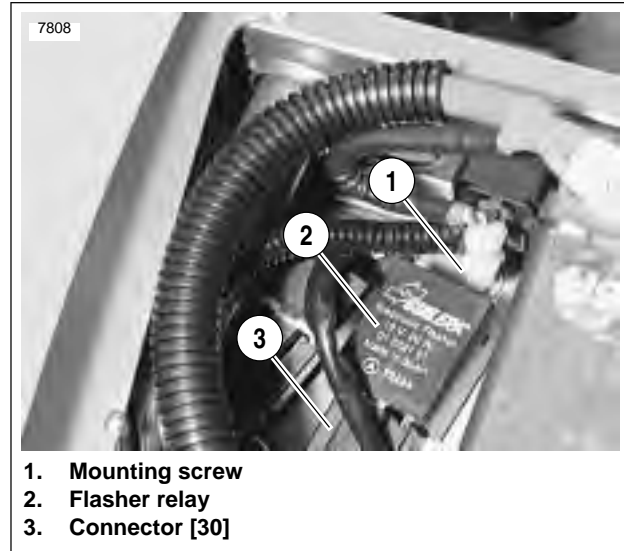


Figure 7-70. Turn Signal Flasher

REMOVAL

NOTE

The individual handlebar switches are not repairable. Replace switch assembly upon switch failure.

Right Side

1. Detach throttle cables.
2. See Figure 7-71. Cut cable strap to access right handlebar switch connector [22] behind dash. Detach connector [22] from wiring harness.
3. Cut as many cable straps as necessary to access brake switch connector [170]. Detach connector [170] from wiring harness.

Left Side

1. Remove three screws from handlebar switch.
2. Separate switch housings and remove from handlebar.
3. See Figure 7-73. Cut cable strap(s) as necessary to access left handlebar switch connector [24] and clutch switch connector [95] behind dash. Detach connector [24] from wiring harness.
4. Remove connector [95] from clutch switch.

INSTALLATION

Right Side

1. Attach throttle cables to hand control.
2. Position housings on right handlebar by engaging stud on front housing with hole in handlebar. Fasten housings with two screws. Tighten to 25-33 **in-lbs** (2.8-3.7 Nm).
3. See Figure 7-71. Route switch housing wiring harness between front forks. Attach connector [170] and connector [22] to wiring harness. Fasten wiring harness behind dash with **new** cable straps.
4. Adjust throttle cables. See 1.18 **THROTTLE CABLES**.

WARNING

Be sure that all lights and switches operate properly before operating motorcycle. Low visibility of rider can result in death or serious injury. (00316a)

5. See Figure 7-72. Check handlebar switch for proper operation. If operation fails, reread procedure and verify that all steps were performed.
 - a. Turn ignition key switch to IGN.
 - b. Start motorcycle.
 - c. Turn ignition key switch to OFF.

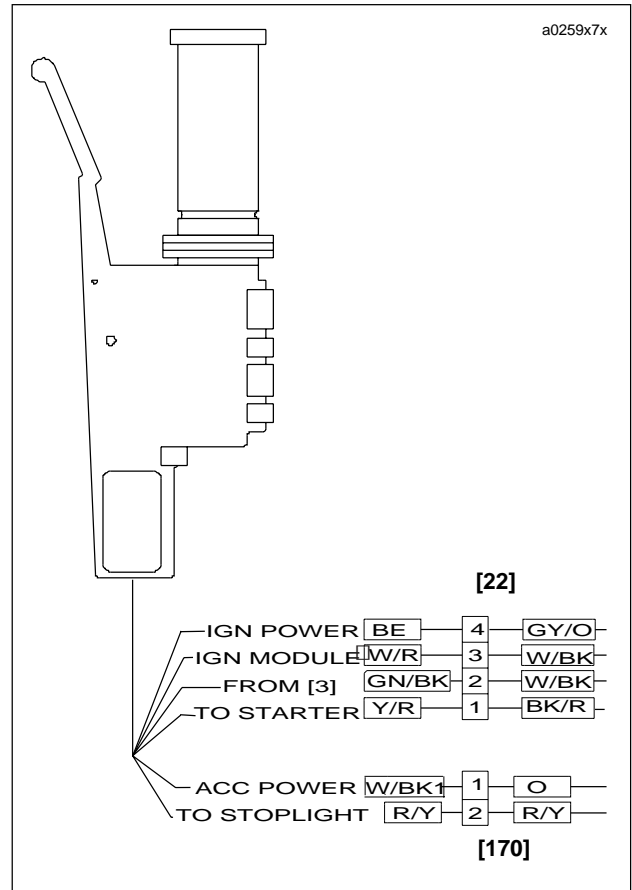
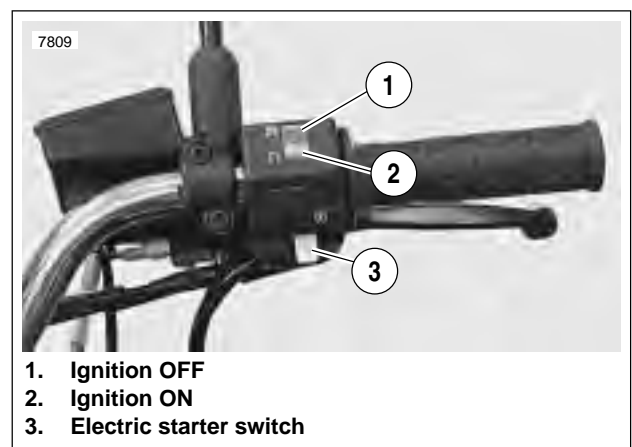


Figure 7-71. Right Handlebar Switch Connection [22] and Brake Switch Connection [170]



1. Ignition OFF
2. Ignition ON
3. Electric starter switch

Figure 7-72. Right Handlebar Switches

Left Side

1. Attach switch housing to handlebar with three screws. Tighten screws to 25-33 **in-lbs** (2.8-3.7 Nm).
2. See [Figure 7-73](#). Route switch housing wiring harness between front forks. Attach connector [24] and connector [95] to wiring harness. Fasten wiring harness behind dash with **new** cable straps.

WARNING

Be sure that all lights and switches operate properly before operating motorcycle. Low visibility of rider can result in death or serious injury. (00316a)

3. See [Figure 7-74](#). Check handlebar switch for proper operation. If operation fails, reread procedure and verify that all steps were performed.
 - a. Turn ignition key switch to IGN.
 - b. Check headlamp LOW and HIGH beam settings.
 - c. Set headlamp to LOW beam. Press passing lamp switch. Headlamp should flash HIGH beam for as long as the switch is pressed.
 - d. Check left and right turn signals.
 - e. Activate horn by pressing horn switch.
 - f. Turn ignition key switch to OFF.

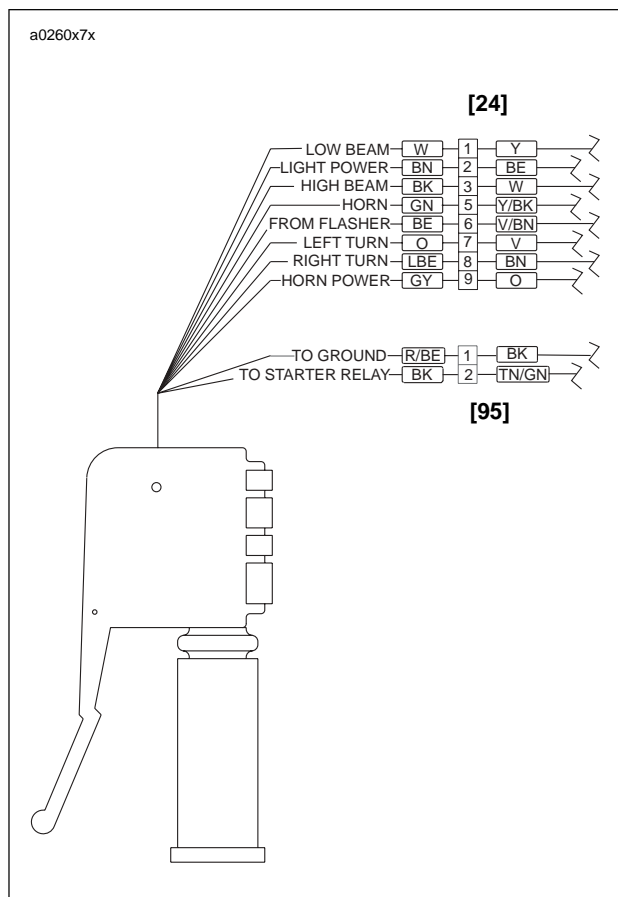


Figure 7-73. Left Handlebar Switch Connection [24] and Clutch Switch Connection [95]

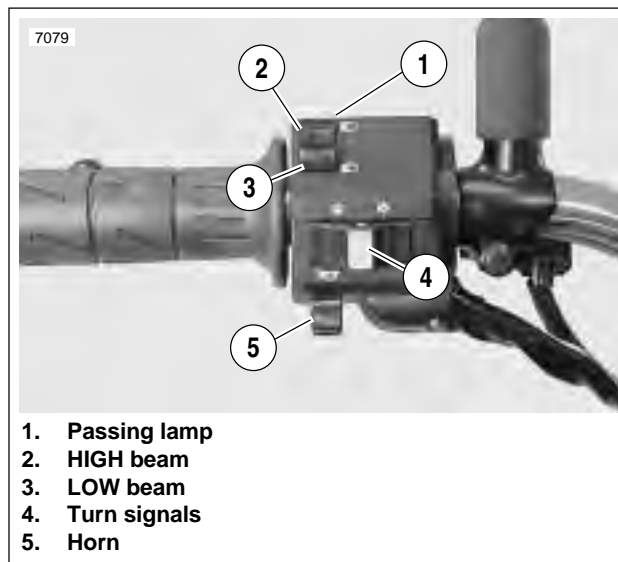


Figure 7-74. Left Handlebar Switches

REMOVAL

1. Pull bottom of horn forward slightly and remove nut (metric) from back of horn.
2. See [Figure 7-75](#). Detach Y/BK power wire and BK ground wire from terminal clips.
3. Remove horn from motorcycle.

INSTALLATION

1. See [Figure 7-75](#). Connect Y/BK power wire and BK ground wire to terminal clips.
2. Attach horn to bracket with nut (metric). Tighten nut to 25-33 **in-lbs** (2.6-3.7 Nm).
3. Check horn operation. If horn does not sound or fails to function satisfactorily, see [TROUBLESHOOTING](#).
 - a. Turn ignition key switch to IGN.
 - b. Press horn switch to activate horn.
 - c. Turn ignition key switch to OFF.

TROUBLESHOOTING

1. If the horn does not sound or fails to function satisfactorily, check for the following conditions:
 - a. Discharged battery.
 - b. Loose, frayed or damaged wiring leading to horn terminal.
2. If battery has a satisfactory charge and wiring appears to be in good condition, test horn grounds and switch using voltmeter.
 - a. See [Figure 7-75](#). Remove Y/BK power and BK ground wires from terminal clips.
 - b. Connect voltmeter positive (+) lead to Y/BK wire.
 - c. Connect voltmeter negative (-) lead to ground.
 - d. Turn ignition key switch to IGN.
3. See [Figure 7-76](#). Depress horn switch and observe voltmeter reading.
 - a. If battery voltage is present, horn or horn grounding is faulty. If horn is faulty, replace unit as an assembly. The horn is not repairable.
 - b. If battery voltage is not present, either horn switch or wiring to horn is faulty. If horn switch is faulty, replace left handlebar switch. See [7.21 HANDLEBAR SWITCHES](#).

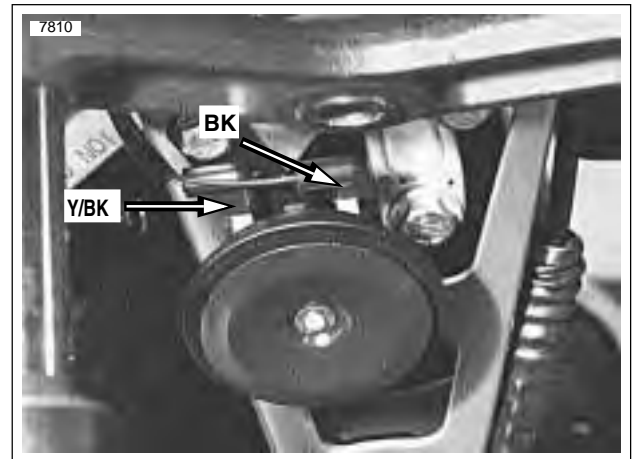


Figure 7-75. Horn Assembly

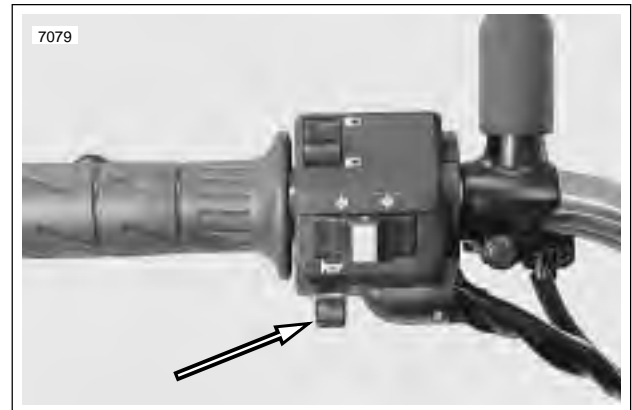


Figure 7-76. Horn Switch Location

GENERAL

See [Figure 7-77](#). The neutral indicator switch (1) is threaded into the transmission portion of the right crankcase half (2); it is immediately forward of the main drive gear shaft (3). The sprocket cover must be removed to test the switch. If switch requires replacement, secondary drive belt and transmission sprocket must also be removed; there is not enough clearance to allow the removal of the switch without first removing the transmission sprocket.

A pin on the shifter drum contacts the neutral indicator switch plunger, completing the neutral indicator circuit. The switch is not repairable. Replace the switch if it malfunctions.

For diagnostic information, see [Section 7.28 INDICATORS](#).

REMOVAL/INSTALLATION

1. Verify that the ignition key switch is turned to OFF.
2. Remove front sprocket cover. See [2.22 SPROCKET COVER](#).
3. See [Figure 7-77](#). Place transmission in first gear. Remove two socket head screws (7) and lockplate (6).

IMPORTANT NOTE

Transmission sprocket nut has left-hand threads. Turn nut clockwise to loosen and remove from main drive gear shaft. Transmission sprocket nut will be damaged if turned counterclockwise to remove.

4. See [Figure 7-77](#). Remove transmission sprocket nut (5) from main drive gear shaft (3).
5. Remove transmission sprocket (4) (with secondary drive belt) from main drive gear shaft (3).
6. Remove wire lead from neutral indicator switch (1). Remove switch from right crankcase half (2).
7. Install **new** neutral indicator switch.
 - a. Apply a light coating of Loctite 243 (blue) to **new** neutral indicator switch (1) threads.
 - b. Install switch in crankcase. Tighten to 36-60 **in-lbs** (4.0-6.8 Nm).
 - c. Connect wire lead to switch.
8. Install transmission sprocket (4) (with secondary drive belt) onto main drive gear shaft (3). See [6.14 TRANSMISSION SPROCKET](#).
9. Install sprocket cover. See [2.22 SPROCKET COVER](#).

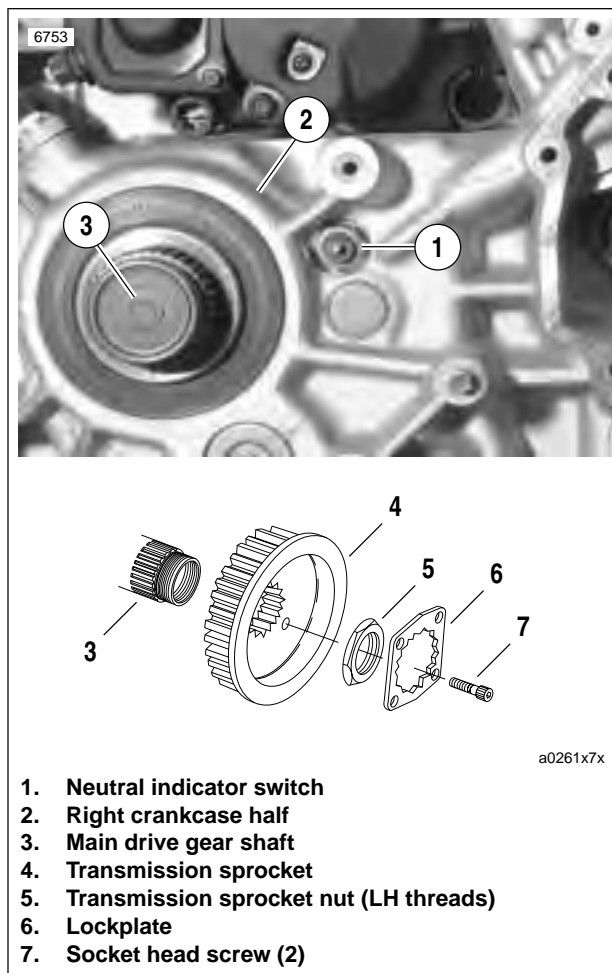


Figure 7-77. Neutral Indicator Switch

GENERAL

Fuses

See [Figure 7-78](#). The fuse block is on the right side of the frame under the seat. The block contains five replaceable fuses. Two spare fuses (4) are attached to the fuse block.

The lights (1), key switch (2) and system (3) fuses are each rated at 15 amperes. The ignition (5) and accessory (6) fuses are rated at 7.5 amperes.

Remove fuses by pulling them straight up and out of the fuse block. Inspect metal strip inside opaque plastic shell. A broken metal strip indicates a blown fuse. Always replace fuses with fuses of the same amp rating.

Always investigate the cause of blown fuses before replacing them. See your Buell dealer for more information.

Circuit Breakers

See [Figure 7-79](#). The 30 ampere main circuit breaker is under the seat next to the battery.

Since the circuit breaker is the automatic-reset type, the bimetallic breaker contacts automatically close (completing the circuit) once they have cooled down from the initial overload. If the overload condition still exists, the breaker contacts will again open to interrupt current flow. This opening and closing of the breaker contacts continues as long as the current circuit overload condition exists.

To replace the circuit breaker:

1. Remove seat. See [2.28 SEAT](#).

⚠ WARNING

Disconnect negative (-) battery cable first. If positive (+) cable should contact ground with negative (-) cable connected, the resulting sparks can cause a battery explosion, which could result in death or serious injury. (00049a)

2. Disconnect battery negative cable from battery.
3. Remove acorn nuts, nuts with lock washers and wire leads from circuit breaker studs. Tag wire leads for ease of assembly.
4. Remove circuit breaker from circuit breaker bracket by carefully prying clip tab, located on left side, open and sliding circuit breaker out.

NOTE

Bank Angle Sensor will require reinstallation if bracket is removed. See [7.5 BANK ANGLE SENSOR](#).

5. Install in the reverse order. Tighten screw (if bracket was removed) to 25-27 **in-lbs** (2.8-3.1 Nm). Tighten metal nut to 15-18 **in-lbs** (1.7-2 Nm). Tighten plastic acorn nuts to 1-3 **in-lbs** (0.1-0.3 Nm).

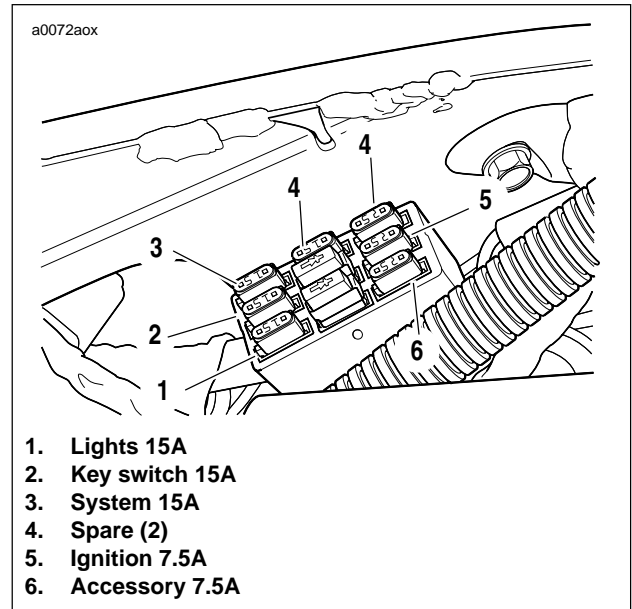


Figure 7-78. Fuse Block

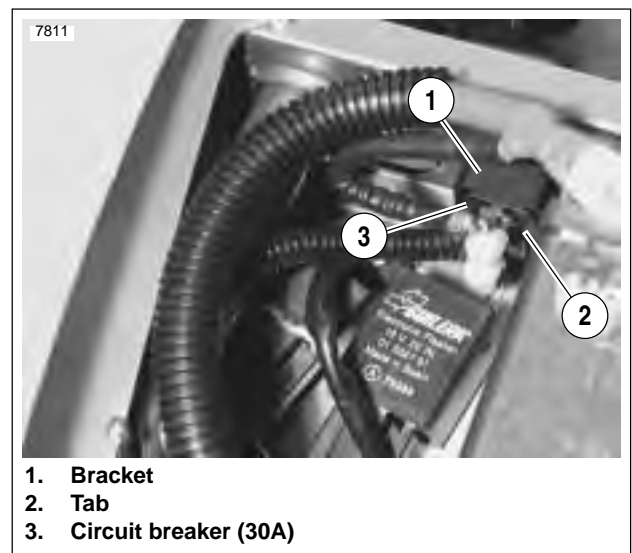


Figure 7-79. Circuit Breaker

⚠ WARNING

After installing seat, pull upward on front of seat to be sure it is in locked position. While riding, a loose seat can shift causing loss of control, which could result in death or serious injury. (00070a) injury.

6. Install seat. See [2.28 SEAT](#).

GENERAL

The electronic speedometer consists of a speed sensor, function switch and the speedometer. The speed sensor is mounted on the right side of the transmission case, below the starter. The sensor circuitry is that of a Hall-Effect sensor that is triggered by the gear teeth of 5th gear on the transmission main shaft. The output from the sensor is a series of pulses that are interpreted by speedometer circuitry to control the position of the speedometer needle and the liquid crystal display (LCD) odometer display. The odometer mileage is permanently stored and will not be lost when electrical power is turned off or disconnected. The function switch allows switching, or "togglng" between the odometer and trip odometer displays. To zero the trip odometer, have the odometer display visible, press and keep the function switch depressed. The trip odometer mileage will be displayed for 2 to 3 seconds and then the mileage will return to 0 miles.

The odometer can display seven numbers to indicate a maximum of 999999.9 miles. The trip odometer can display five numbers for a maximum of 9999.9 miles.

Circuitry in the speedometer also conditions the sensor input to provide an input to the turn signal canceller.

Replace the speedometer if the unit is not working properly. However, before replacing a component, check that the problem is not caused by a faulty cable or loose wire connection.

DIAGNOSTICS

Blast Models have a speedometer with self-diagnostic capabilities.

General

The reset switch is used to change the odometer display between mileage and trip values and to reset the trip odometer. It is also used to identify the speedometer calibration and to enter the diagnostic mode, clear diagnostic codes and exit the diagnostic mode.

Diagnostic Mode

The diagnostic mode is entered by turning the ignition switch from OFF to ON while holding the reset switch in. The normal power-up sequence will occur before entering the diagnostic mode. Diagnostic codes set during this power-up sequence will be stored as well.

NOTE

Make sure no Diagnostic Codes are indicated before reset is held in for more than 5 seconds or diagnostic information will be lost.

When in the diagnostic mode, the odometer will display the first diagnostic code. When the trip switch is pressed again, the next code will be shown. If the trip switch is pressed for more than 5 seconds at any time while in the diagnostic mode, the **diagnostic code displayed will be erased**.

There are seven different diagnostic codes available. They are as follows:

Table 7-23. Trouble Codes

CODE	DESCRIPTION
d01	Speed sensor power output shorted low
d02	Speed sensor power output shorted high or open
d03	Not used
d04	Not used
d05	Speed sensor return shorted high
d06	Speed sensor return shorted low
d07	Not used
d08	Speedometer power over voltage
d09	Speed output shorted high
d10	Speed output shorted low or open

CAL XX Speedometer application calibration number:
14 = domestic

When in the diagnostic mode, all codes are displayed in sequence from d01 to d10.

As a code appears in the display (for instance d02), it will read "d02SEt" if set or "d02CLr" if clear.

The diagnostic mode is exited either by turning ignition from ON to OFF to ON again without depressing the reset switch or if a speed signal greater than 5 m.p.h. is detected.

Diagnostics cannot be performed if a system voltage is less than 9 VDC or greater than 16 VDC. The only exception is **d08** which is set when the system voltage is greater than 16 VDC.

After all diagnostic codes are displayed, the speedometer calibration number is displayed (**CAL14**).

Reset Switch Replacement

1. Remove odometer reset boot from instrument panel.
2. Unscrew bezel ring from reset switch and pull switch out from behind instrument panel.
3. Cut wires from switch.
4. Install **new** switch wires using SEALED WIRE SPLICES.
5. Position **new** reset switch in squared boss Behind instrument panel.
6. Install bezel inside of rubber boot.
7. Install rubber boot/bezel assembly to odometer reset switch.

REMOVAL

1. See [Figure 7-80](#). Remove two fasteners holding dash panel to upper triple clamp.

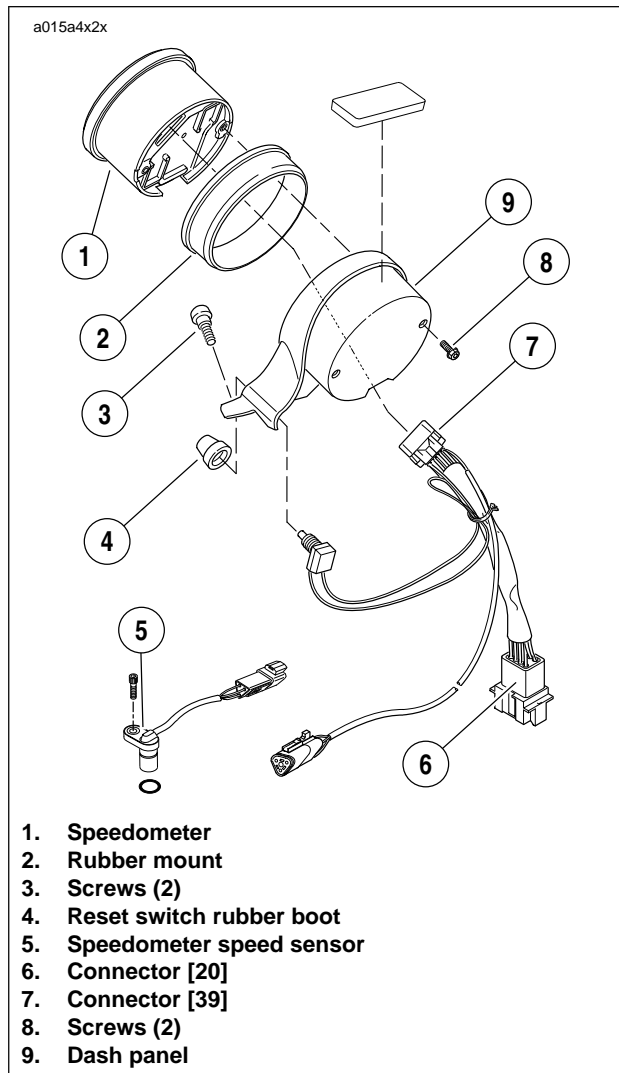


Figure 7-80. Speedometer

2. Unplug connector [20]. Cut and remove cable strap.
3. The rubber mount is a tight fit in the dash panel. To remove the speedometer without damaging the dash panel:
 - a. See [Figure 7-81](#). Loosen screw until head is approximately 0.125 in. (3.2 mm) above the back surface of the dash.
 - b. Liberally apply glass cleaner around circumference of rubber mount.
 - c. See [Figure 7-82](#). Position dash and speedometer on edge of hard surfaced bench and apply even pressure to dash to open a gap between the speedometer and dash.
 - d. Remove two screws that secure speedometer to rear of dash panel.
 - e. Apply more glass cleaner in gap and work speedometer free from dash.
4. Depress tab and remove speedometer connector [39].

INSTALLATION

1. Install connector [39] on back of speedometer.
2. Lubricate rubber mount with glass cleaner and insert speedometer into dash panel.
3. Install speedometer to dash panel with two screws in back of dash panel.
4. Connect connector [20] and replace cable strap to adjacent wire bundle.
5. Apply Loctite 243 (blue) to first few threads of dash panel mounting screws.
6. Position dash panel in mounting position on upper triple clamp and install two screws. Tighten screws to 30-36 in-lbs (3-4 Nm).



Figure 7-81. Speedometer Fasteners

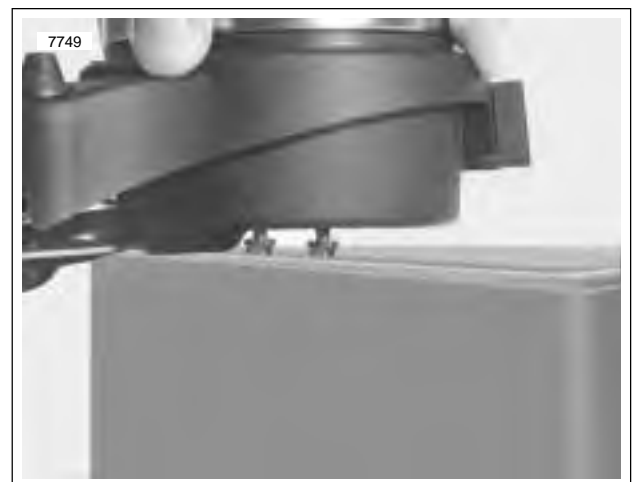


Figure 7-82. Removing Speedometer

REMOVAL

1. Remove seat. See 2.28 SEAT.
2. See Figure 7-83. Locate and unplug speedometer sensor 3-place connector [65]. Connector is located in the right side frame cavity.
3. See Figure 7-84. Locate speed sensor on engine case right side, to the rear of the starter solenoid.
4. Remove speed sensor mounting screw.
5. Remove sensor with o-ring from engine case cavity and pull wires down through frame.

INSPECTION

NOTE

Debris on speedometer sensor can result in false speedometer reading, especially during break-in. Always clean and troubleshoot speedometer sensor and verify proper operation before replacing speedometer. See [Speedometer Sensor Test](#).

Clean any debris from speedometer sensor.

INSTALLATION

1. Install speedometer sensor in engine case.
2. Install screw and tighten to 80-100 **in-lbs** (9-11 Nm).
3. Connect connector [65] in right side frame cavity.

WARNING

After installing seat, pull upward on front of seat to be sure it is in locked position. While riding, a loose seat can shift causing loss of control, which could result in death or serious injury. (00070a)

4. Install seat. See 2.28 SEAT.

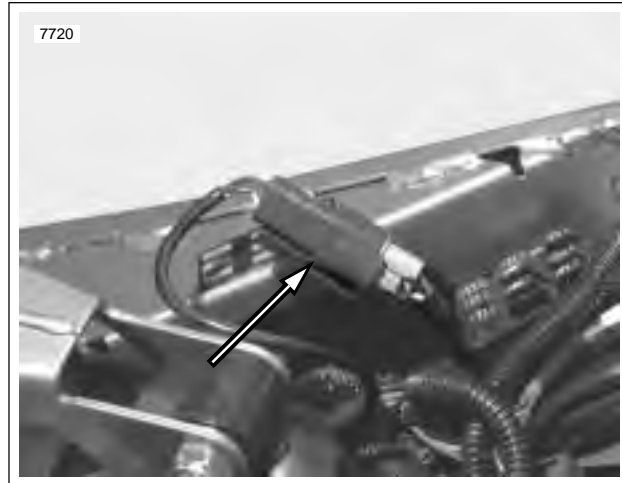
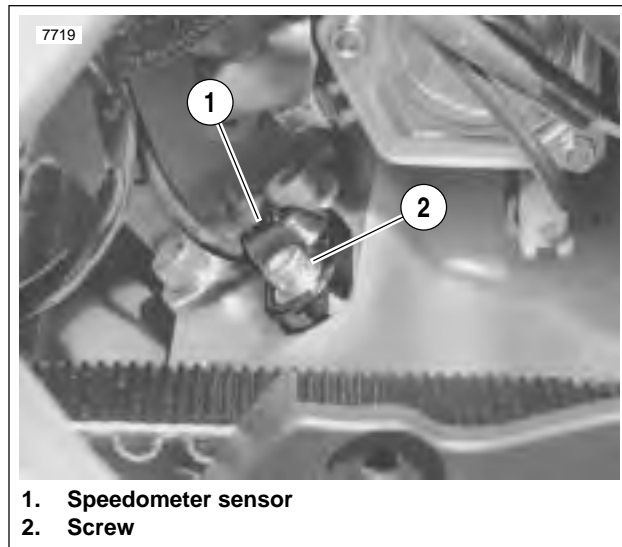


Figure 7-83. Speedometer Sensor Connector [65]



1. Speedometer sensor
2. Screw

Figure 7-84. Speedometer Sensor

GENERAL

See [Figure 7-85](#). Use the SPEEDOMETER TESTER (Part No. HD-41354) for speedometer diagnostics. These diagnostics may include:

- Checking speedometer operation.
- Testing speedometer needle sweeping action.

The tester generates a simulated speedometer sensor signal. This signal aids in determining whether speedometer replacement is necessary. It can also be used to simulate running engine conditions for ignition system troubleshooting.

NOTES

- Use the following procedures in conjunction with the manual supplied with the speedometer tester.
- Test results may be inaccurate if tester battery is low.

TESTING

NOTE

The SPEEDOMETER TESTER (Part No. HD-41354) cannot be used to verify the calibration of a speedometer and it will not verify the speedometer's function to support legal proceedings. It's purpose is to verify speedometer function when performing service diagnosis or repair. It can also assist in determining if speedometer replacement is necessary.

Speedometer Operation Test

1. See [Figure 7-86](#). Locate the 3-place Deutsch connector [65] for the speedometer sensor to right of battery and disconnect.
2. Attach speedometer tester connector to speedometer sensor connector.
3. Place speedometer tester power switch in the ON position. Place signal switch in the OUT position.
4. Turn vehicle ignition switch ON.
5. Begin test.
 - a. Press ENTER on the tester keypad.
 - b. Enter a frequency from [Table 7-24](#). Note that different markets use different frequencies.
 - c. Verify that speedometer display reads the corresponding speed. To change the test frequency, press CLEAR to cancel and enter the new frequency. Press ENTER to begin and reverify.

NOTE

The speedometer should be accurate within 0-4 MPH (0-6.5 KPH).

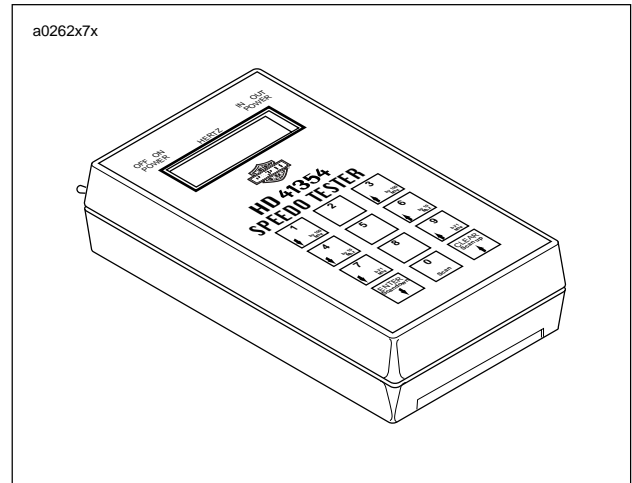


Figure 7-85. Speedometer Tester

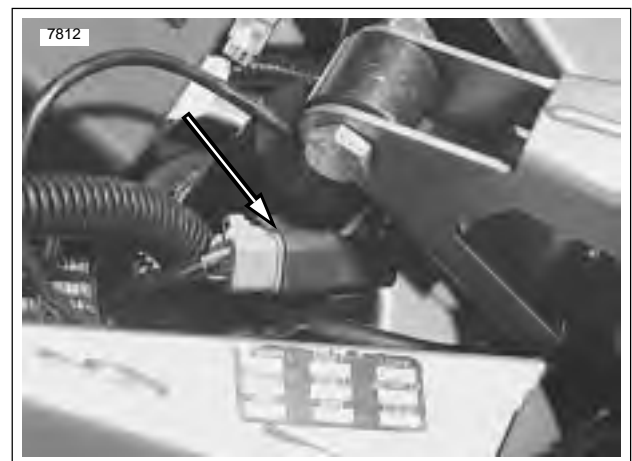


Figure 7-86. Speedometer Sensor Connector [65]

Table 7-24. Speedometer Test Frequency in Hertz (Hz)

MARKET	20 MPH (30 KPH)	40 MPH (60 KPH)	60 MPH (100 KPH)	80 MPH (130 KPH)
USA	606	1207	1803	2392
CAN	606	1208	1804	2393

Speedometer Needle Sweep Test

The tester's sweep function moves the speedometer needle through the full range of movement. This allows for testing the smoothness of operation and checking for hesitancy or a stuck needle.

1. See [Figure 7-86](#). Disconnect speedometer sensor connector. Attach speedometer tester connector to speedometer sensor connector.
2. Place speedometer tester power switch in the ON position. Place signal switch in the OUT position.
3. Turn vehicle ignition switch ON.
4. Begin test by pressing 0 on the tester keypad, then pressing ENTER. The tester will scan for two seconds, then the tester will put out a 1 Hz signal.
5. Select a test range.
 - a. Press 2 to select LO range (1-20 Hz).
 - b. Press 5 to select CEN range (21-999 Hz).
 - c. Press 8 to select HI range (1000-20,000 Hz).
6. After selecting a range, use the corresponding arrow keys to accelerate through the range. As you move through the speed range, check for smooth needle movement.
 - a. If testing LO range, press 1 or 3.
 - b. If testing CEN range, press 4 or 6.
 - c. If testing HI range, press 7 or 9.

Speedometer Sensor Test

If the speedometer is inoperative, but backlighting and odometer work, the speedometer sensor may not be working.

See [Figure 7-87](#). Fabricate a test harness using the following parts.

- Two Deutsch 3-place socket housings (Part No. 72113-94BK).
- Deutsch 3-place pin housing (Part No. 72103-94BK).
- Six lengths of 18 gauge wire, each 6.0 in. (15 cm) long.
- Six socket terminals (Part No. 72191-94).
- Six pin terminals (Part No. 72190-94).
- Two secondary locks (socket) (Part No. 72153-94).
- Two secondary locks (pin) (Part No. 72143-94).

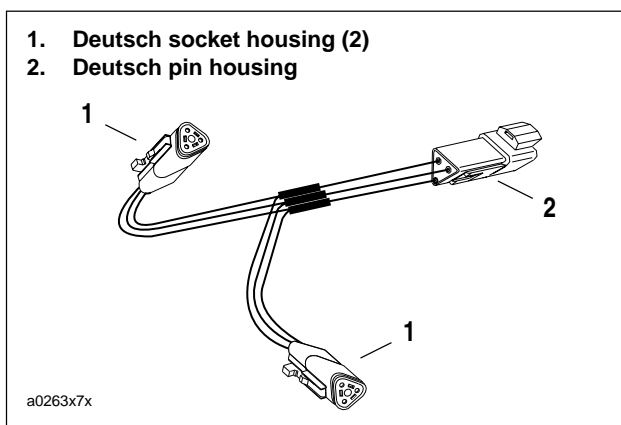


Figure 7-87. Test Harness

Before attempting the actual speedometer sensor check, two system checks must be made. Install the test harness at the speed sensor connector [65]. See [Figure 7-87](#).

- Test for voltage to sensor by checking for 8-12 VDC on red wire in connector [65B].
 - Then check for continuity to ground on black wire in connector [65B].
1. Raise rear wheel off floor using REAR WHEEL SUPPORT STAND (Part No. B-41174).
 2. Install the test harness between the speedometer sensor connectors [65A] and [65B].
 3. Place speedometer tester power switch in the ON position. Place signal switch in the IN position.
 4. Plug the speedometer tester into the test harness. Turn vehicle ignition switch ON.
 5. Press ENTER on the tester keypad.
 6. Rotate the motorcycle's rear wheel.
 - a. If reading on speedometer tester changes as wheel is rotated, speedometer sensor is OK.
 - b. If reading does not change, speedometer sensor is suspect. Remove sensor and check for debris, clean, replace sensor and retest. If still non-functional, install a known, good speedometer sensor and test again for proper operation.

IMPORTANT NOTE

When using the speedometer troubleshooting diagnostic charts on the following pages, use the reference numbers below to correlate with those found on the diagnostic flow charts.

1. To enable diagnostic mode: press odometer reset switch and turn ignition/key switch to ON.
2. To clear codes: depress and hold reset switch for 5 seconds with set code displayed.
3. To return speedometer to normal operating state: cycle ignition/key switch.
4. Remove seat. See [2.28 SEAT](#).
5. Test results may be inaccurate if tester battery is low.
6. Refer to [7.27 SPEEDOMETER PERFORMANCE CHECK](#).
7. Sensor can also be tested with Speedometer Tester (HD-41354) and Test Harness. See [SPEEDOMETER SENSOR TEST](#).
8. Remove sensor and check for accumulation of debris on sensor; if debris is not present, replace sensor. If debris is present, clean sensor and repeat test. Replace sensor as required. See [7.26 SPEEDOMETER SENSOR](#).
9. Sweep tool has frequency jumps in full scale sweeps. Perform sweep in 3 stages as described in speedometer tester manual.
10. Disconnecting speed sensor or install speedometer sensor will cause code **d02** to set.

Speedometer Test: Chart 1

ODOMETER, TRIP ODOMETER AND RESET SWITCH TESTING

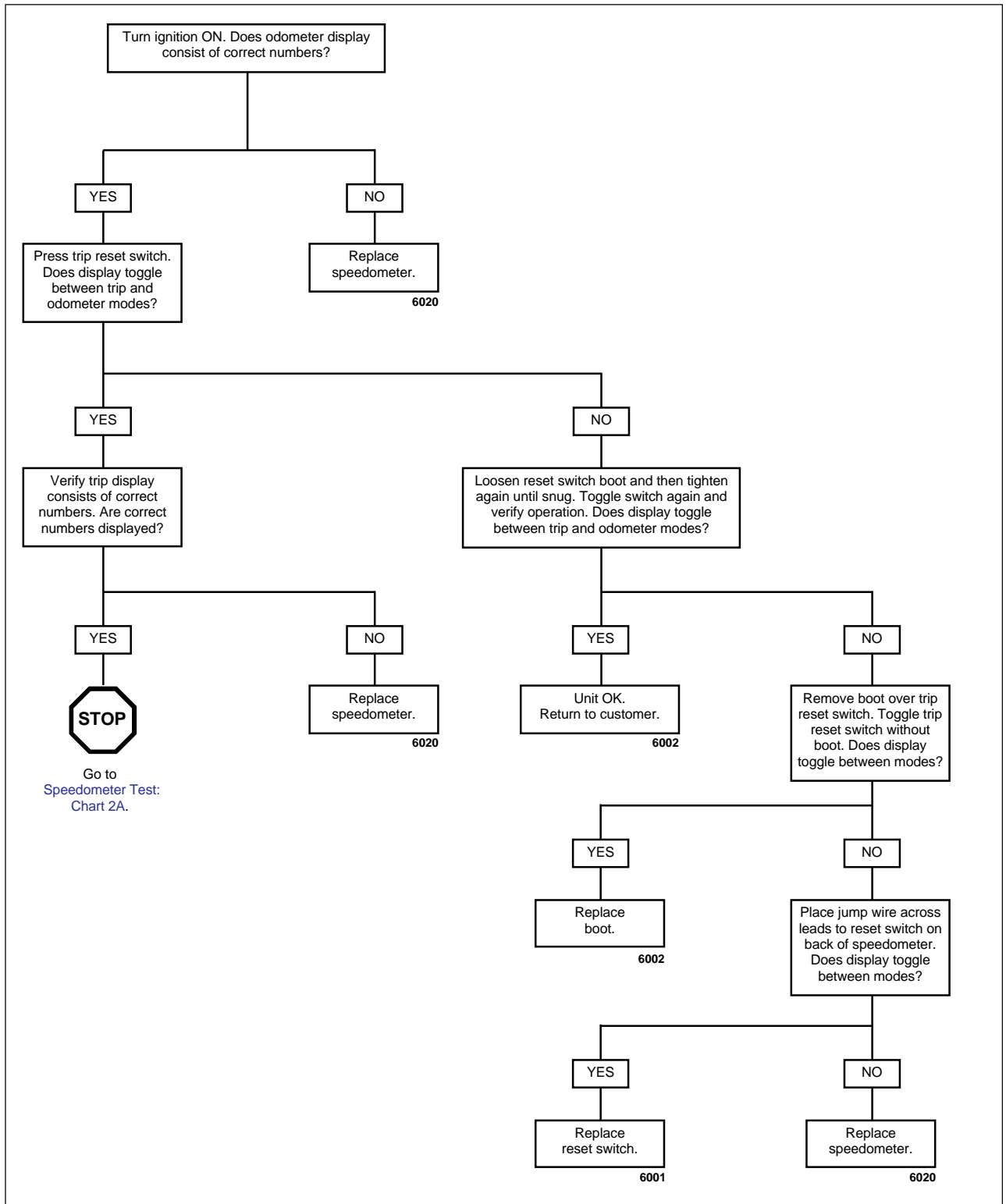


Figure 7-88. Speedometer Test Chart 1

Speedometer Test: Chart 2A

INOPERATIVE, INACCURATE OR ERRATIC SPEEDOMETER

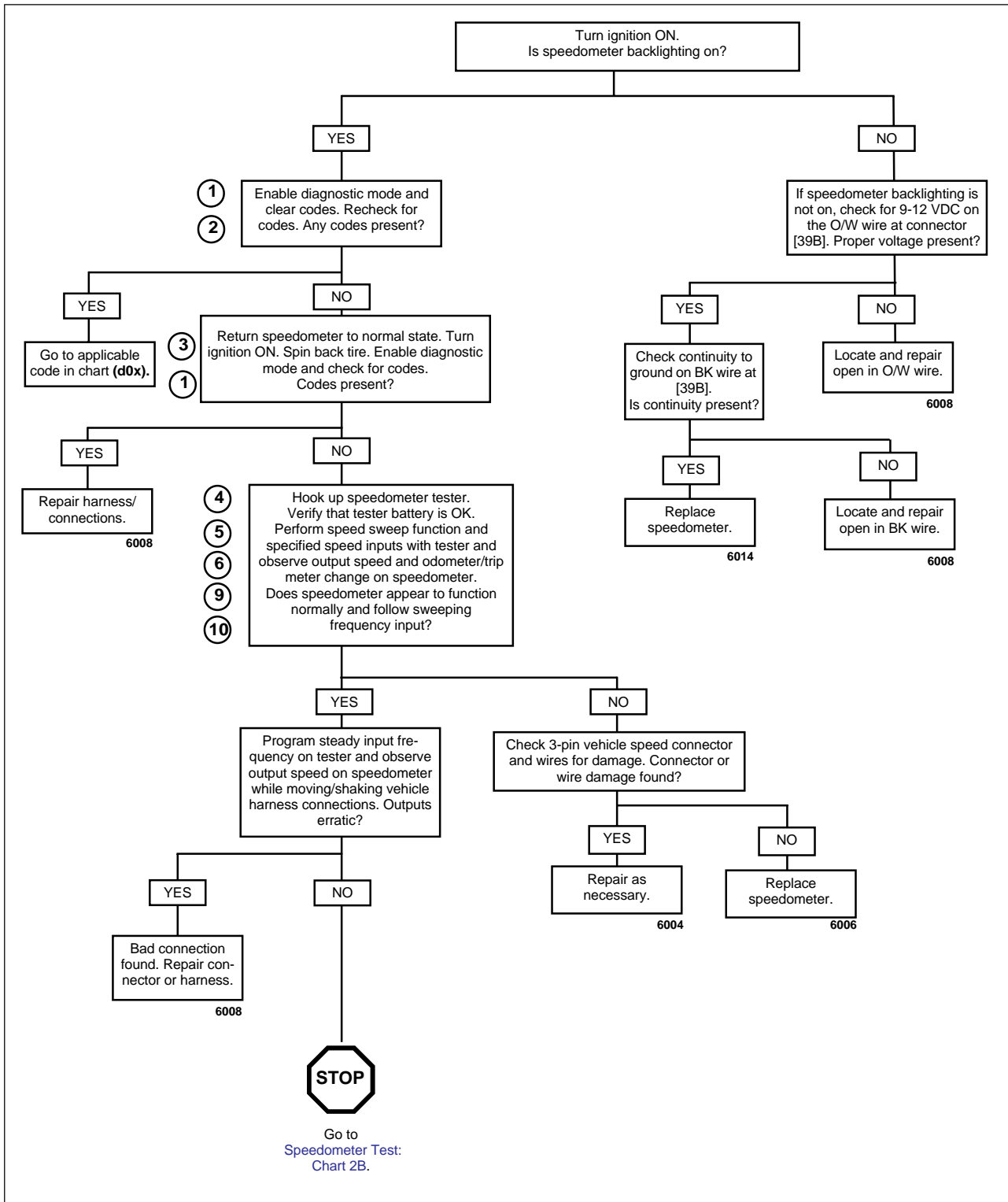


Figure 7-89. Speedometer Test Chart 2A

Speedometer Test: Chart 2B

INOPERATIVE, INACCURATE OR ERRATIC SPEEDOMETER

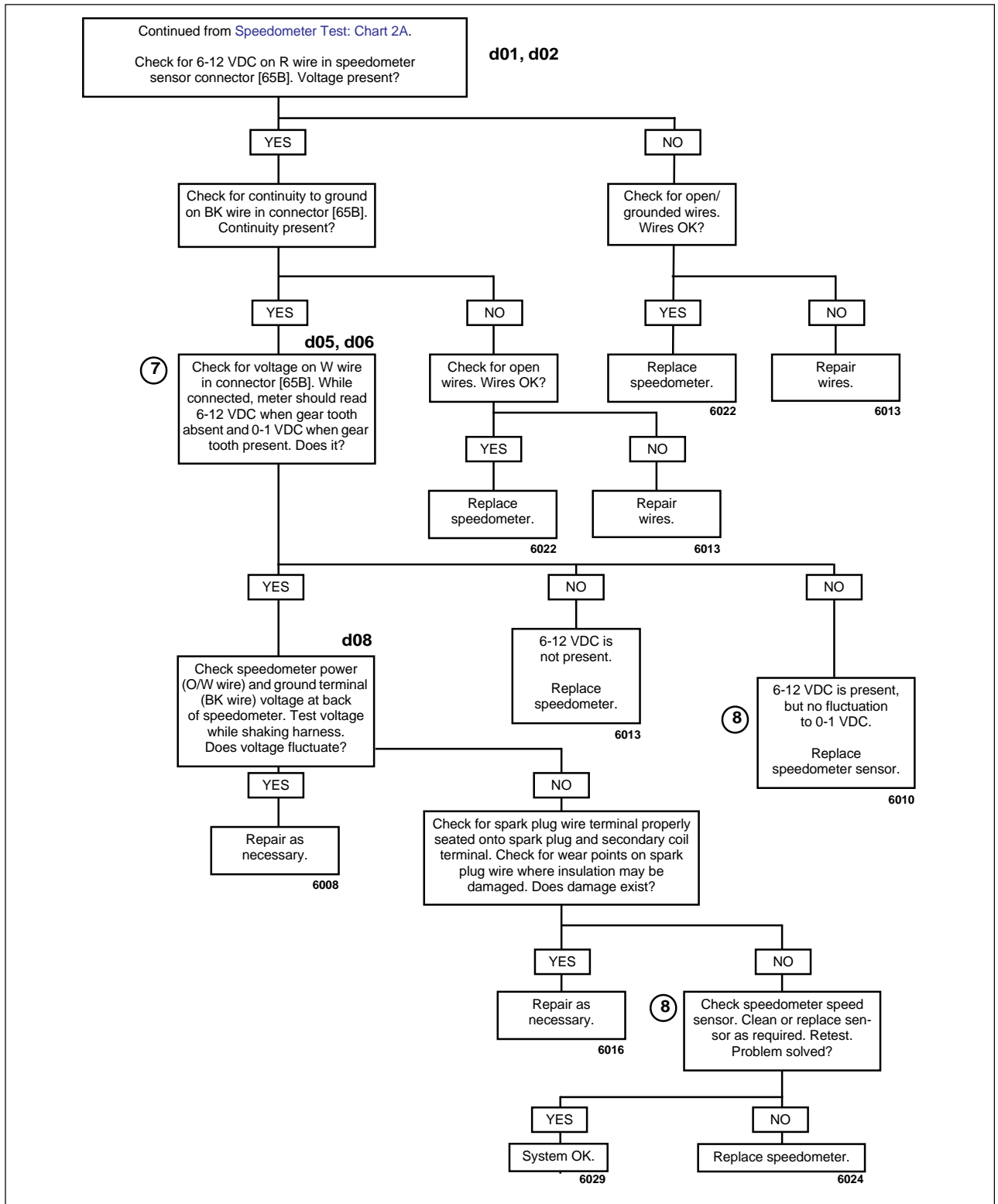


Figure 7-90. Speedometer Test Chart 2B

GENERAL

Indicators are Light Emitting Diodes (LEDs) located in the speedometer. LEDs are non-repairable. Replace the speedometer if an LED fails.

DIAGNOSTICS

See diagnostic tables below.

Indicator Lights

Problem: Light(s) inoperative.

Follow the diagnostic flow charts below. If replacement is necessary, replace speedometer. See [7.25 ELECTRONIC SPEEDOMETER](#).

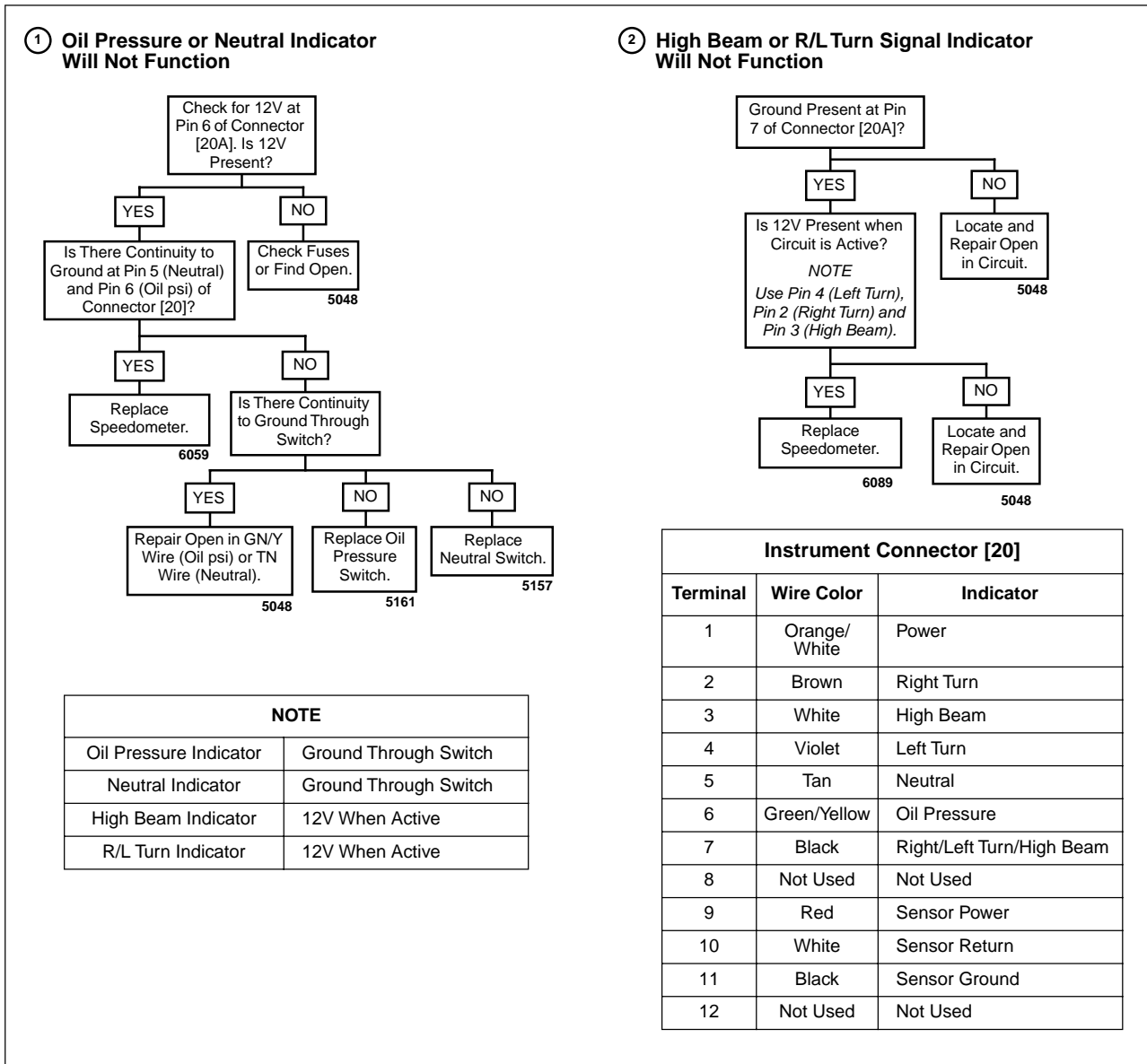


Figure 7-91. Diagnostics

GENERAL

The main wiring harness runs from the front of the motorcycle (behind dash) to the rear of the frame tray under the seat where it connects to the tail lamp/turn signal mini-harness.

REMOVAL

1. Remove seat. See [2.28 SEAT](#).

⚠ WARNING

To prevent accidental vehicle start-up, which could cause death or serious injury, disconnect negative (-) battery cable before proceeding. (00048a)

⚠ WARNING

Disconnect negative (-) battery cable first. If positive (+) cable should contact ground with negative (-) cable connected, the resulting sparks can cause a battery explosion, which could result in death or serious injury. (00049a)

2. Disconnect battery cables, negative cable first.
3. Remove battery. See [7.16 BATTERY](#).
4. Remove fuel tank. See [4.2 FUEL TANK COVER/FUEL TANK](#).
5. Remove windscreen. See [2.26 WINDSCREEN](#).
6. Remove headlamp housing and disconnect connector [38]. See [7.17 HEADLAMP](#).
7. Note location of cable straps and cut three cable straps on frame backbone that secure main wiring harness to frame. Disconnect harness from T-studs.
8. Disconnect speedometer connector [39].
9. Disconnect right and left handlebar switch connectors [22] and [24], front brake switch blade connectors [170] and clutch switch connector [95].
10. Tag and disconnect right and left front turn signal bullet connectors.
11. Disconnect ignition switch connector [33].
12. Note location of cable strap and cut cable strap on horn wire and remove two blade connectors [122] from horn.



Figure 7-92. Ignition Connector [10]

13. See [Figure 7-92](#). Unhook connector [10] from the T-stud on the left side of the frame backbone.
14. Note location of cable strap and cut cable strap on ignition coil and TP sensor/auto-enrichener and ignition module harness.

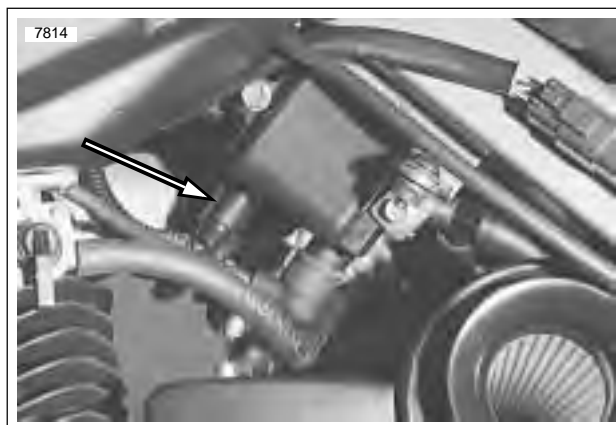


Figure 7-93. Coil Connector [83]

15. See [Figure 7-93](#). Disconnect ignition coil connector [83] at coil.

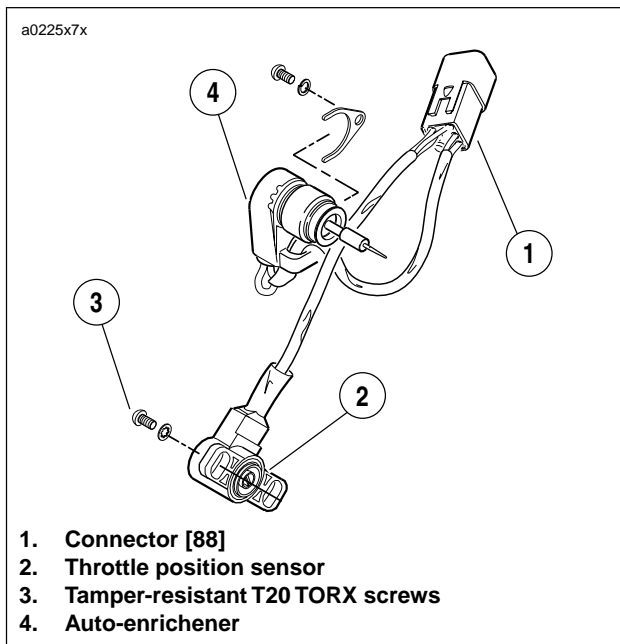


Figure 7-94. TP Sensor/Auto-Enrichener Connector [88]

16. See [Figure 7-94](#). Disconnect TP sensor/auto-enrichener connector [88] under frame backbone.
17. Disconnect starter connector [128] at starter solenoid.
18. See [Figure 7-92](#). Disconnect ignition connector [10] on left side of frame backbone.
19. Feed harness through frame and upper tie bar mount.
20. Remove nut and clamp that secures oil hoses and wiring harness on right side of motorcycle.
21. Disconnect neutral switch bullet connector [172].
22. Disconnect speed sensor connector [65] located in frame tray on right side.
23. Disconnect sidestand switch connector [60] above swing arm.
24. Disconnect oil pressure switch connector [120].
25. Disconnect rear brake line switch connector [121] located above swingarm on right side of motorcycle.

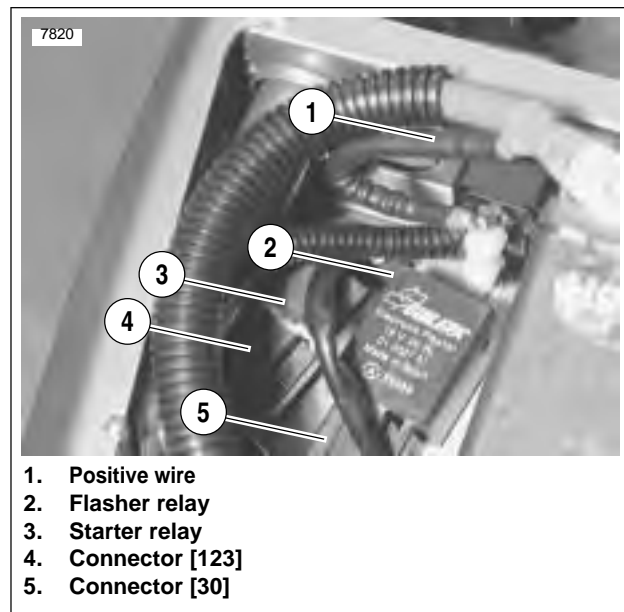


Figure 7-95. Flasher Relay Connector [30]

26. See [Figure 7-95](#). Unplug flasher relay connector [30] and starter relay connector [123] located in frame tray on right hand side.
27. Unplug system relay connector [171] located in frame tray on left side.
28. See [Figure 7-95](#). Disconnect positive (+) wire from battery on circuit breaker (upper stud).
29. Disconnect tail lamp/turn signal mini harness connector [7] located under seat.
30. Unhook fuse block.
31. Note location, and cut two cable straps on wire to frame and wire on voltage regulator mount. Disconnect voltage regulator wire and wire attached to frame.
32. Pull main wiring harness out through rear of frame.

INSTALLATION

1. Feed main wiring harness through frame from back to front.
2. See [Figure 7-95](#). Connect flasher relay connector [30] to flasher relay and starter relay connector [123] to starter relay.



Figure 7-96. System Relay

3. See [Figure 7-96](#). Connect system relay connector [171] to system relay.
4. Install fuse block.
5. Connect positive (+) wire to circuit breaker. Tighten metal nut to 15-18 **in-lbs** (1.7-2 Nm). Tighten plastic acorn nut to 1-3 **in-lbs** (0.1-0.3 Nm).
6. Feed negative (-) wire across frame and connect to voltage regulator mount and frame. Use two cable straps to secure wires.

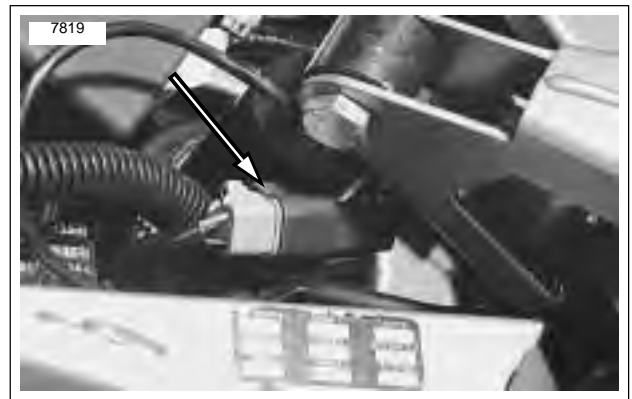


Figure 7-97. Speed Sensor Connector [65]

7. See [Figure 7-97](#). Mate speed sensor connector [65]. Tuck excess harness into right frame pocket.
8. Connect two blade terminals to stoplight switch above swingarm.
9. Mate sidestand switch connector [60] located above swingarm cable strap wires.
10. Install starter connector [128] located under starter solenoid.
11. Install neutral switch bullet connector [172].
12. Install oil pressure switch connector [120] to oil pressure switch. Route wire around oil pump.
13. Install hose clamp around hoses and oil pressure switch and neutral switch wires. Secure clamp with **new** locknut.
14. Attach main wiring harness to T-studs.
15. Feed wire harness through upper tie bar mount in two bundles.

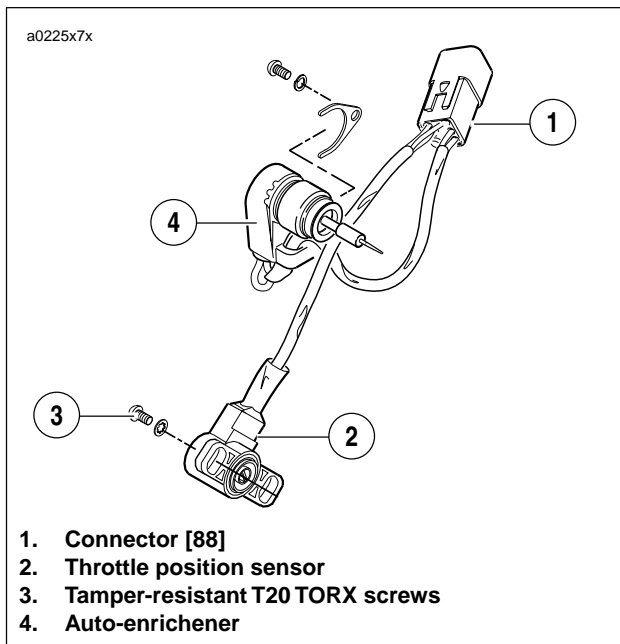


Figure 7-98. TP Sensor/Auto-Enrichener Connector [88]

16. See [Figure 7-98](#). Mate TP sensor/auto-enrichener connector [88] and secure with cable strap.
17. Install connector [83] to coil and secure with cable strap.
18. See [Figure 7-92](#). Mate ignition module connector [10] and attach to T-stud on left side of frame backbone.
19. Feed longer bundle at front through frame hole to left side of motorcycle. Attach harness to T-stud.
20. Hook right side of harness to two T-studs on right side of motorcycle.
21. Mate right handlebar switch connector [22], front brake lamp switch connector [170]. Secure wires with cable straps.
22. Mate left handlebar switch connector [24] and clutch switch connector [95]. Secure wires with cable straps.
23. Connect speedometer connector [39].
24. Mate ignition switch connector [33].
25. Install left and right front turn signal bullet connectors as marked during removal.

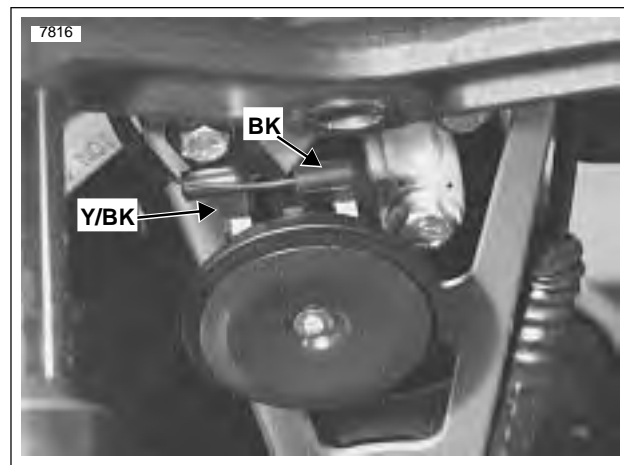


Figure 7-99. Horn Connector [122]

26. See [Figure 7-99](#). Feed horn wires through frame hole on right side and install connector [122] to horn. Cable strap wires to isolator mount.
27. Cable strap main wiring harness to frame backbone with three cable straps.
28. Connect headlamp connector [38] and install headlamp housing. See [7.17 HEADLAMP](#).
29. Install windscreen. See [2.26 WINDSCREEN](#).
30. Install fuel tank. [4.2 FUEL TANK COVER/FUEL TANK](#).

⚠ WARNING

Connect positive (+) battery cable first. If positive (+) cable should contact ground with negative (-) cable connected, the resulting sparks can cause a battery explosion, which could result in death or serious injury. (00068a)

31. Install battery and reconnect battery cables, positive cable first. See [7.16 BATTERY](#).

⚠ WARNING

After installing seat, pull upward on front of seat to be sure it is in locked position. While riding, a loose seat can shift causing loss of control, which could result in death or serious injury. (00070a)

32. Install seat. See [2.28 SEAT](#).

⚠ WARNING

Be sure that all lights and switches operate properly before operating motorcycle. Low visibility of rider can result in death or serious injury. (00316a)

33. Check for proper operation of headlamp, turn signals, brake lamp and starting, charging and ignition systems.

[Table Of Contents](#)

SUBJECT	PAGE NO.
A.1 Tools	A-1
B.1 Connectors	B-1
B.2 Amp Multilock	B-3
B.9 Deutsch	B-8
B.4 Standard Deutsch Terminal Crimps	B-12
B.3 Sealed Splice	B-13
B.8 Wiring Diagrams	B-15

APPENDICES

